



Caution: Gasoline or gasoline vapors are highly flammable. A fire could occur if an ignition source is present. Never drain or store gasoline or diesel fuel in an open container, due to the possibility of fire or explosion. Have a dry chemical (Class B) fire extinguisher nearby.



Caution: Remove the fuel tank cap and relieve the fuel system pressure before servicing the fuel system in order to reduce the risk of personal injury.



Attention: the Seal is not to be re-used. Replace the Seal with the replacement Seal included in the package.



Important: Removal of the Lock Ring will require the use of a special spanner wrench



Important: Transfer the Level Sensor from the old Fuel Module to the new Fuel Module if applicable.

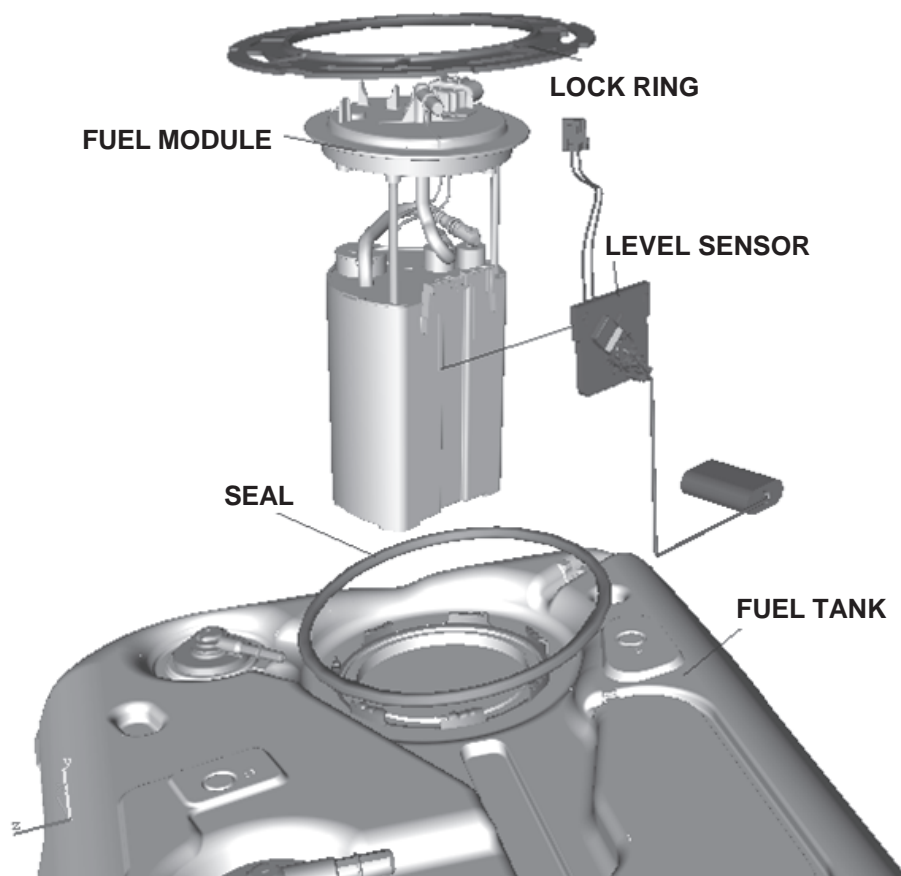

Disclaimer: These instructions are intended as a general guide. Graphical representations are typical, features will vary by make and model. Refer to the appropriate manufacturers service information for further detail including fuel tank removal procedures or fuel module access panel location.



www.ACDelco.com

1-800-ACDelco

Fuel Module and/or Level Sensor Replacement

PART NO. **19133527** SHEET **1** OF **3**

ALL INFORMATION WITHIN ABOVE BORDER TO BE PRINTED EXACTLY AS SHOWN ON 8.5 x 11 WHITE 16 POUND NON-BOND RECYCLABLE PAPER. PRINT ON BOTH SIDES, EXCLUDING TEMPLATES. TO BE UNITIZED IN ACCORDANCE WITH GM SP0 SPECIFICATIONS.

DATE	REVISION	AUTH	DR
18MR05	Initial Release-Chirag Shah		
21SE05	Revision A For Production Release-LMG		

TITLE	
INSTALLATION INSTRUCTIONS	
Fuel Module and/or Level Sensor Replacement	
PART NO. 19133527 SHEET 1 OF 3	



Attention : L'essence ou les vapeurs d'essence sont hautement inflammables. Un incendie pourrait se produire si une source d'allumage est présente. Ne jamais vidanger ou entreposer de l'essence ou du carburant diesel dans un contenant ouvert, à cause des possibilités d'incendie ou d'explosion. Garder un extincteur chimique sec (catégorie B) à portée de la main.



Attention : Retirer le bouchon du réservoir d'essence et libérer la pression du circuit d'alimentation avant de procéder à son entretien de façon à réduire le risque de blessures.



Attention : le joint ne doit pas être réutilisé. Remplacer le joint par le joint de remplacement contenu dans l'ensemble.



Important : Le retrait de l'anneau bloqueur exige l'utilisation d'une clé universelle spéciale.



Important : Transférer le détecteur de niveau de l'ancien module de carburant au nouveau, le cas échéant.

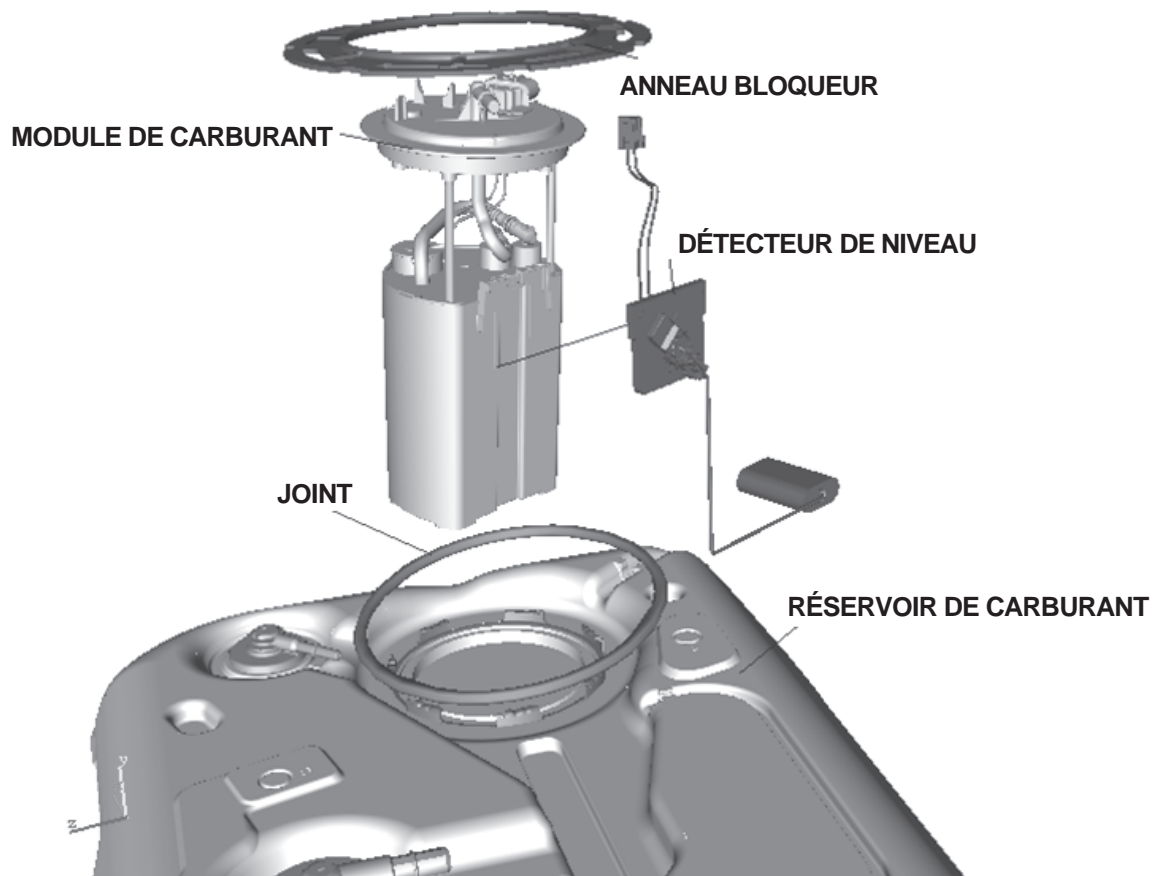

Renonciation : Ces instructions sont conçues comme un guide général. Les représentations graphiques sont typiques, les options peuvent varier selon les marques et les modèles. Consulter les informations de service du fabricant pour de plus amples détails sur les procédures de retrait du réservoir d'essence ou l'emplacement du panneau d'accès au module de carburant.



www.ACDelco.com

1-800-ACDelco

PART NO. **19133527** SHEET **2** OF **3**

ALL INFORMATION WITHIN ABOVE BORDER TO BE PRINTED EXACTLY AS SHOWN ON 8.5 x 11 WHITE 16 POUND NON-BOND RECYCLABLE PAPER. PRINT ON BOTH SIDES, EXCLUDING TEMPLATES. TO BE UNITIZED IN ACCORDANCE WITH GM SP0 SPECIFICATIONS.

DATE	REVISION	AUTH	DR

TITLE	
INSTALLATION INSTRUCTIONS	
PART NO. 19133527 SHEET 2 OF 3	



Precaución: La gasolina o los vapores de la gasolina son sumamente inflamables. Podría ocurrir un incendio si hay presente una fuente de encendido. Nunca drene ni almacene gasolina o combustible diesel en un recipiente abierto, ya que podrían ocasionarse incendios o explosiones. Tenga a la mano un extinguidor de fuego de sustancias químicas secas (Clase B).



Precaución: Quite la tapa del tanque de combustible y alivie la presión del sistema de combustible antes de darle servicio, a fin de reducir el riesgo de lesiones personales.



Atención: el sello no debe ser reutilizado. Reemplace el sello por el sello de reemplazo que se incluye en el paquete.



Importante: La extracción del anillo de seguridad requerirá el uso de una llave para tuercas especial



Importante: Si es aplicable, transfiera el sensor de nivel del anterior módulo de combustible al nuevo módulo de combustible.

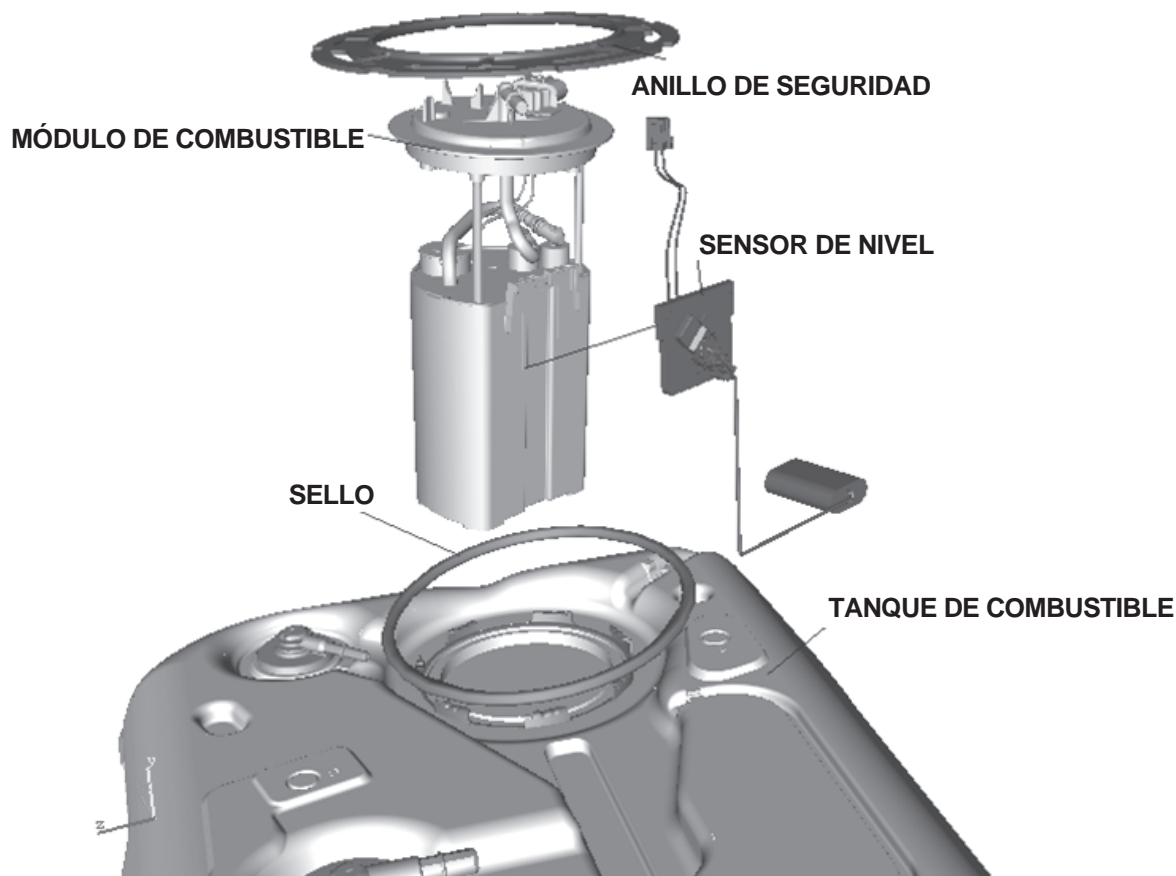

Salvedad: Estas instrucciones son sólo una guía general. Las representaciones gráficas son típicas, las funciones variarán según marca y modelo. Consulte la información de servicio propio de los fabricantes para mayores detalles, incluyendo los procedimientos de extracción del tanque de combustible o ubicación del panel de acceso al módulo de combustible.



www.ACDelco.com

1-800-ACDelco

PART NO. **19133527** SHEET **3** OF **3**

ALL INFORMATION WITHIN ABOVE BORDER TO BE PRINTED EXACTLY AS SHOWN ON 8.5 x 11 WHITE 16 POUND NON-BOND RECYCLABLE PAPER. PRINT ON BOTH SIDES, EXCLUDING TEMPLATES. TO BE UNITIZED IN ACCORDANCE WITH GM SP SPECIFICATIONS.

DATE	REVISION	AUTH	DR

TITLE			
INSTALLATION INSTRUCTIONS			
PART NO.		SHEET	
19133527		3 OF 3	