

Headlamp Service Kit Installation

Note: This procedure is for Light Duty Pick Ups only.

Procedure

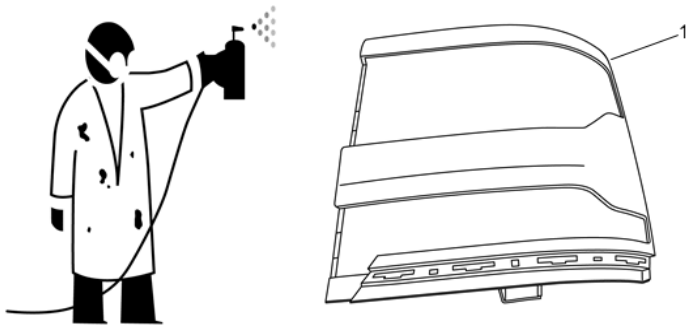

1. Prep and refinish the bezel assembly (1).
2. Remove the headlamp assembly. Refer to Vehicle Service Manual.

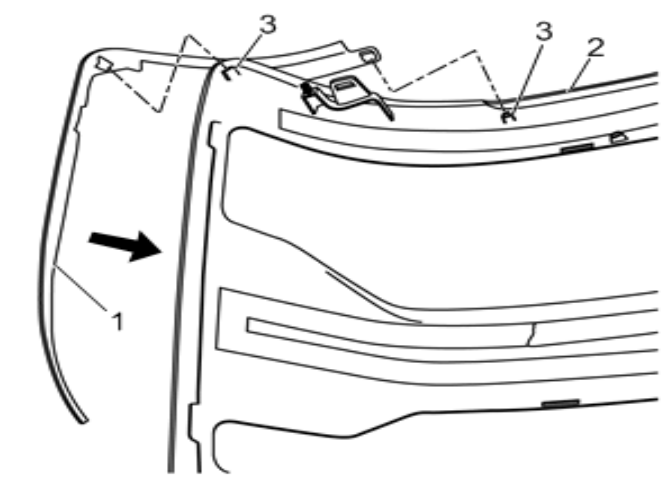

3. Align seal assembly (1) to bezel assembly (2) with pins (3).

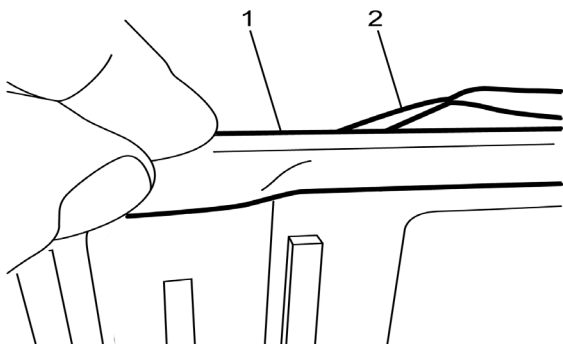

4. Position seal (1) and peel backing (2) away.

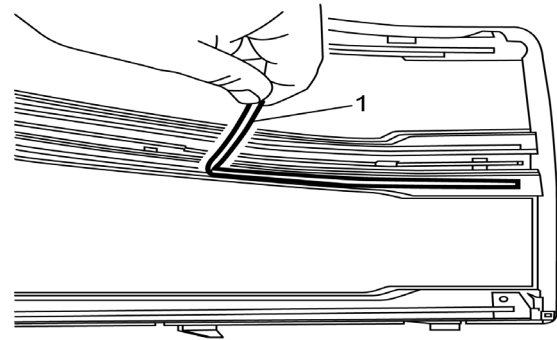

5. Remove the backing strips (1).

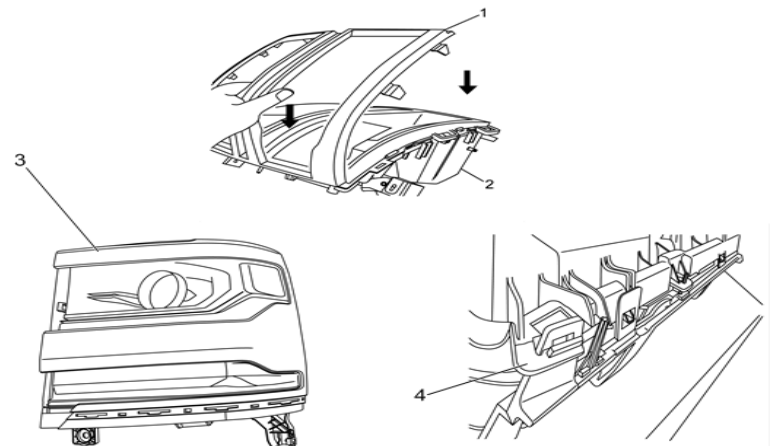

6. Align and apply bezel (1) straight down onto lamp (2).
7. Press bezel (3) firmly to secure tape and lock tabs (4).

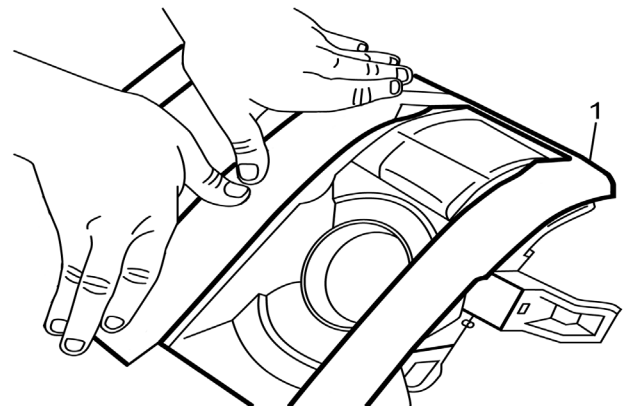

8. Press insert firmly to secure tape.
9. Reinstall headlamp assembly and aim headlamps. Refer to Vehicle Service Manual.

Headlamp Kit

IR 24AP15 PART NO. **19332415** SHEET **1** OF **3**

ALL INFORMATION WITHIN ABOVE BORDER TO BE PRINTED EXACTLY AS SHOWN ON 8.5 x 11 WHITE 16 POUND NON-BOND RECYCLABLE PAPER. PRINT ON BOTH SIDES, EXCLUDING TEMPLATES. TO BE UNITIZED IN ACCORDANCE WITH GM SPECIFICATIONS.

DATE	REVISION	AUTH	DR
24AP15	Initial Release - Randall Prusaitis	2253444	

TITLE	INSTALLATION INSTRUCTIONS Headlamp Kit		
PART NO.	19332415	SHEET	1 OF 3

Installation de la trousse de réparation/entretien des phares

Remarque : Cette procédure concerne uniquement les camionnettes légères.

Procédure

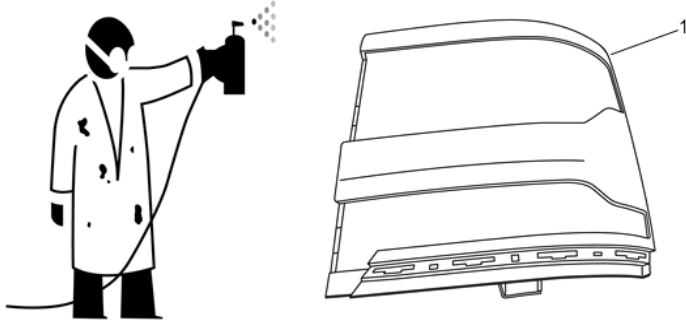

1. Préparer et revernir l'ensemble encadrement (1).
2. Déposer l'ensemble phare.
Se référer au manuel d'entretien du véhicule.

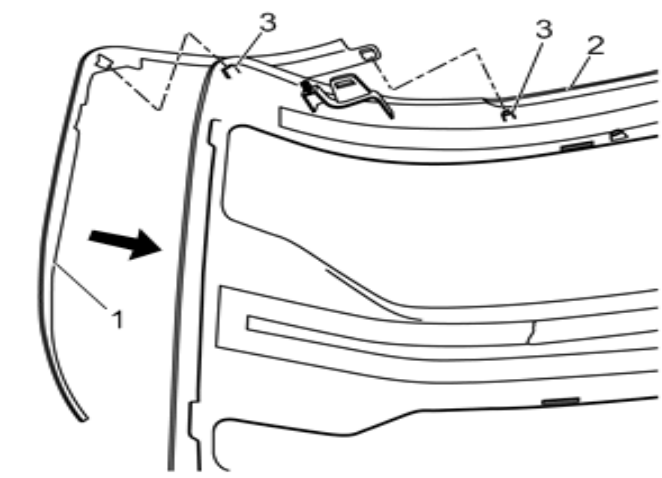

3. Aligner l'ensemble joint d'étanchéité (1) avec l'ensemble encadrement (2) au moyen des axes (3).

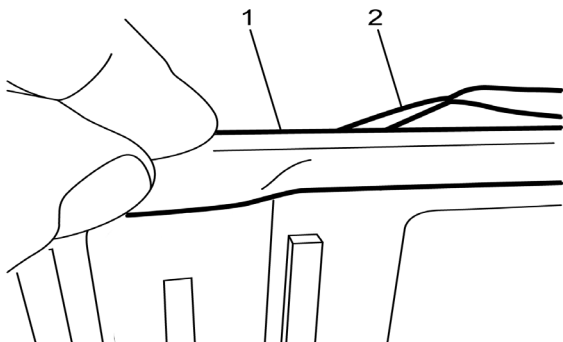

4. Placer le joint d'étanchéité (1) et retirer la pellicule protection (2).

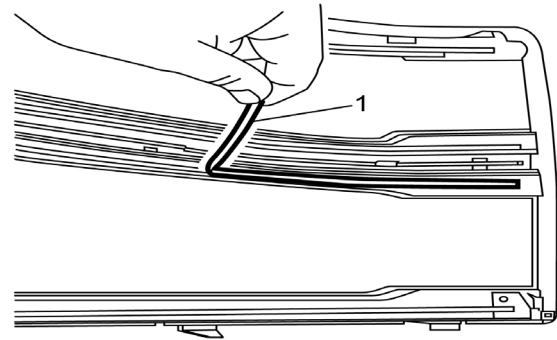

5. Retirer les bandes de protections (1).

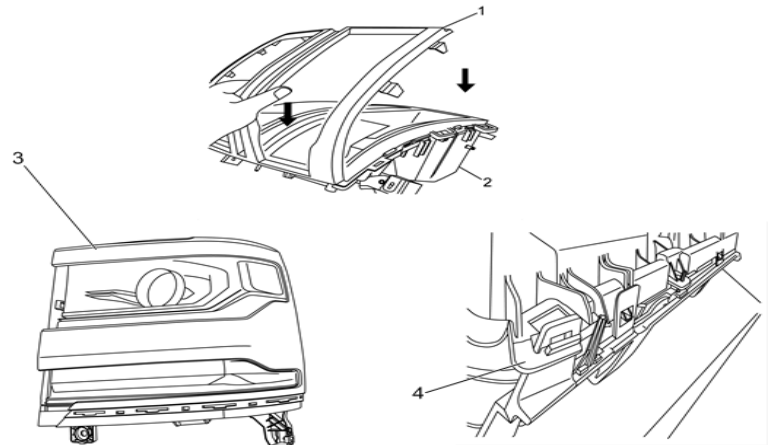

6. Aligner et appliquer l'encadrement (1) directement sur le phare (2).
7. Presser fermement l'encadrement (3) pour assurer l'adhérence du ruban adhésif et pour engager les languettes (4).

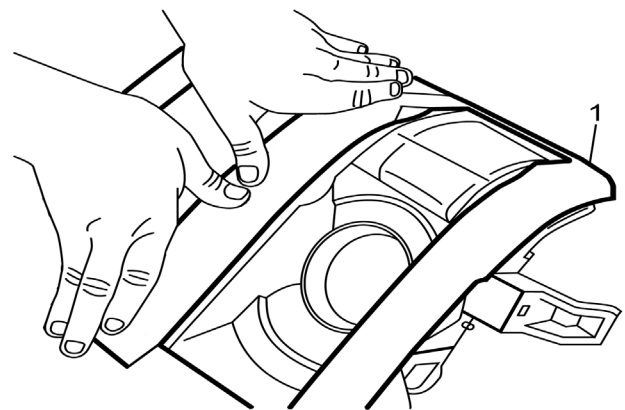

8. Presser fermement la pièce encastrée pour assurer l'adhérence du ruban adhésif.
9. Reposer l'ensemble phare et orienter les phares.
Se référer au manuel d'entretien du véhicule.

Headlamp Kit

IR 24AP15

PART NO.

19332415

SHEET **2** OF **3**

ALL INFORMATION WITHIN ABOVE BORDER TO BE PRINTED EXACTLY AS SHOWN ON 8.5 x 11 WHITE 16 POUND NON-BOND RECYCLABLE PAPER. PRINT ON BOTH SIDES, EXCLUDING TEMPLATES. TO BE UNITIZED IN ACCORDANCE WITH GM SPECIFICATIONS.

DATE	REVISION	AUTH	DR
24AP15	Initial Release - Randall Prusaitis	2253444	

TITLE **INSTALLATION INSTRUCTIONS**
Headlamp Kit

PART NO.

19332415

SHEET **2** OF **3**

Instalación de juego de servicio de faro

Nota: Este procedimiento es sólo para Pickups de servicio ligero.

Procedimiento

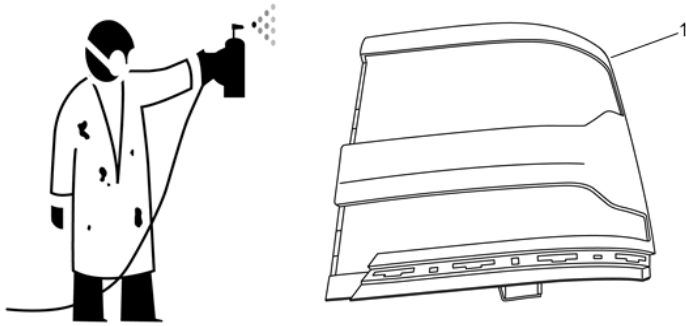

1. Prepare y vuelva a acabar el ensamble del bisel (1).
2. Retire el ensamble del faro. Consulte el manual de servicio del vehículo

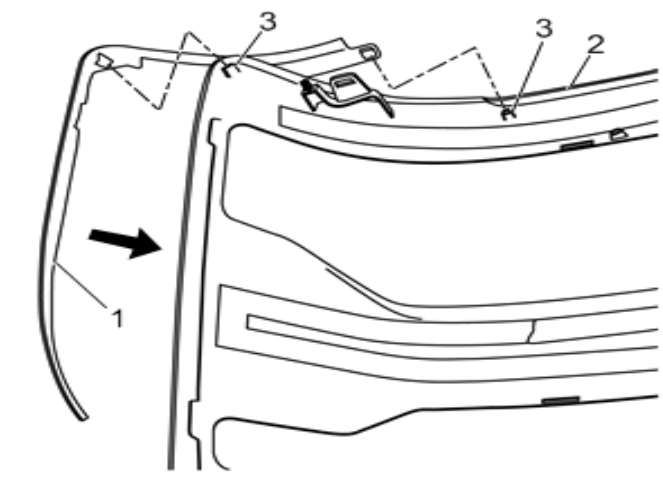

3. Alinee el ensamble del sello (1) al ensamble del bisel (2) con pasadores (3).

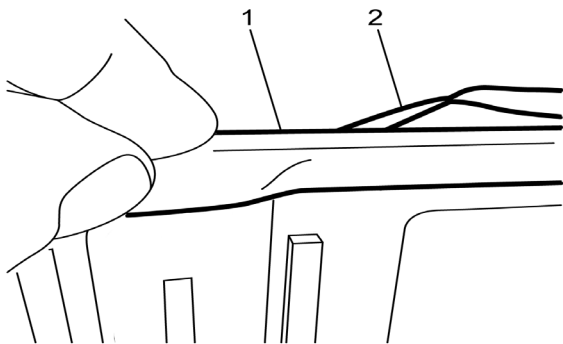

4. Coloque el sello (1) y desprenda el respaldo (2).

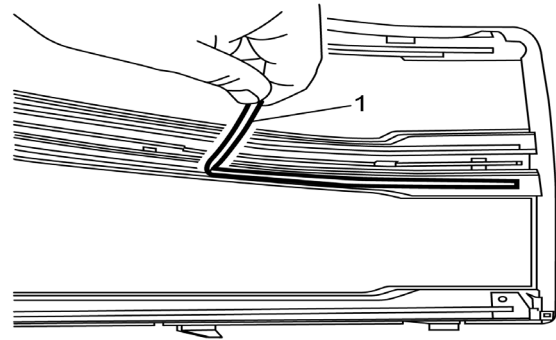

5. Retire las cintas de respaldo (1).

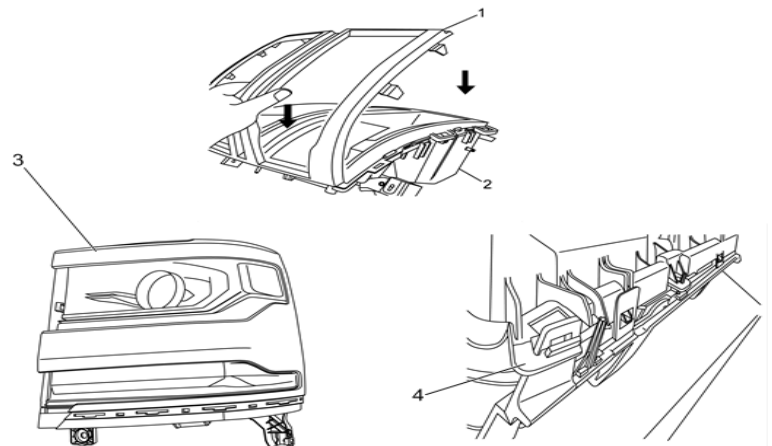

6. Alinee y aplique el bisel (1) rectamente hacia abajo sobre la luz (2).
7. Presione el bisel (3) firmemente para asegurar la cinta y lengüetas de bloqueo (4).

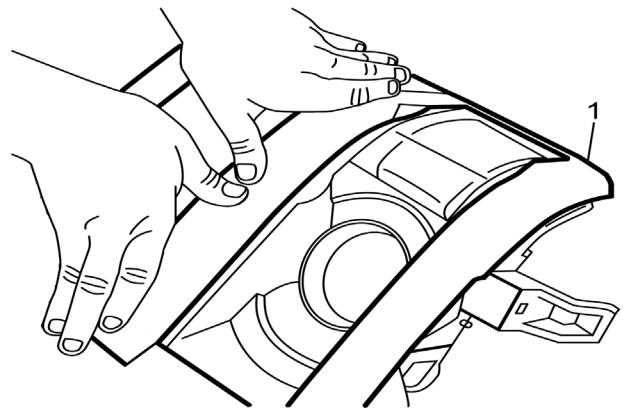

8. Inserte a presión firmemente para asegurar la cinta.
9. Vuelva a instalar el ensamble del faro y apunte los faros. Consulte el manual de servicio del vehículo

Headlamp Kit

IR 24AP15 PART NO. **19332415** SHEET **3** OF **3**

ALL INFORMATION WITHIN ABOVE BORDER TO BE PRINTED EXACTLY AS SHOWN ON 8.5 x 11 WHITE 16 POUND NON-BOND RECYCLABLE PAPER. PRINT ON BOTH SIDES, EXCLUDING TEMPLATES. TO BE UNITIZED IN ACCORDANCE WITH GM SPECIFICATIONS.

DATE	REVISION	AUTH	DR
24AP15	Initial Release - Randall Prusaitis	2253444	

TITLE	INSTALLATION INSTRUCTIONS Headlamp Kit		
PART NO.	19332415	SHEET	3 OF 3