

**Assembly - Disassembly Instructions**

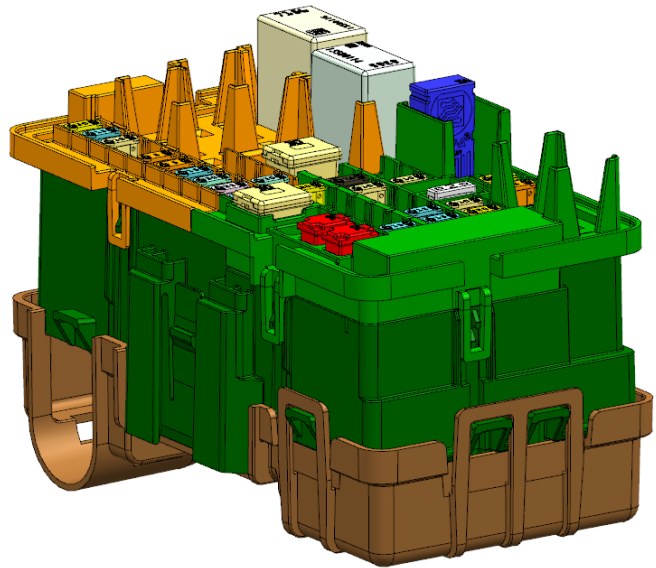
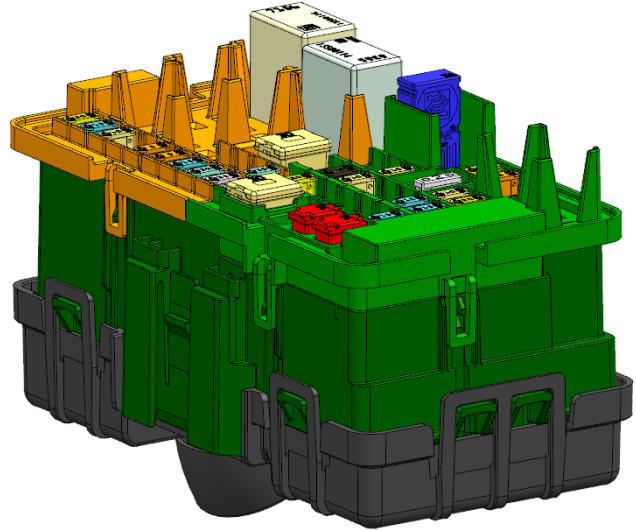

**Assembly / Disassembly Instructions**

**IR 25MY17**

PART NO.

**23322679**

SHEET

**1** OF **84**

ALL INFORMATION WITHIN ABOVE BORDER TO BE PRINTED EXACTLY AS SHOWN ON 8.5 x 11 WHITE 16 POUND NON-BOND RECYCLABLE PAPER. PRINT ON BOTH SIDES, EXCLUDING TEMPLATES. TO BE UNITIZED IN ACCORDANCE WITH GM SPECIFICATIONS.

DATE	REVISION	AUTH	DR
25MY17	Initial Release - Frank Lertz	N/A	

TITLE

**INSTALLATION INSTRUCTIONS  
Assembly / Disassembly Instructions**

PART NO.

**23322679**

SHEET

**1** OF **84**

**Exploded View**

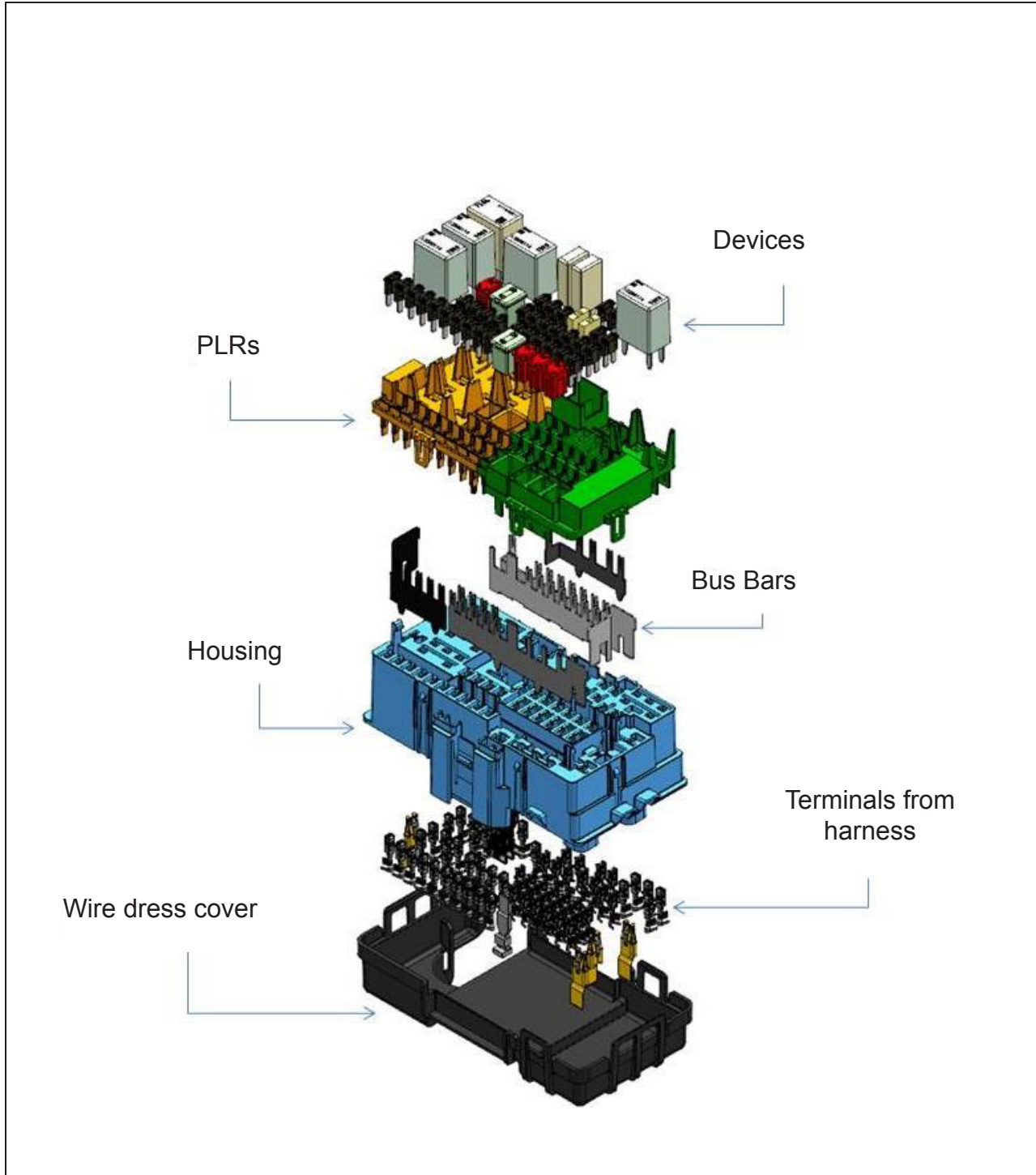



ALL INFORMATION WITHIN ABOVE BORDER TO BE PRINTED EXACTLY AS SHOWN ON 8.5 x 11 WHITE 16 POUND NON-BOND RECYCLABLE PAPER. PRINT ON BOTH SIDES, EXCLUDING TEMPLATES. TO BE UNITIZED IN ACCORDANCE WITH GM SPECIFICATIONS.

DATE	REVISION	AUTH	DR
25MY17	Initial Release - Frank Lertz	N/A	

TITLE	<b>INSTALLATION INSTRUCTIONS Assembly / Disassembly Instructions</b>		
PART NO.	<b>23322679</b>	SHEET	<b>2 OF 84</b>

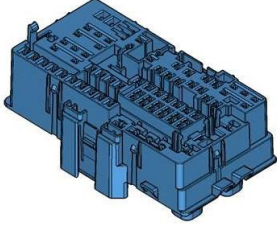
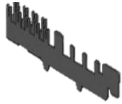
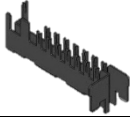
**Bill of Materials**

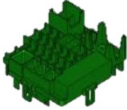
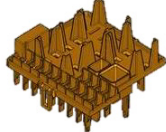
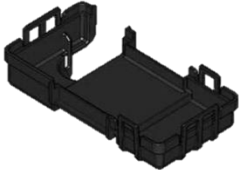
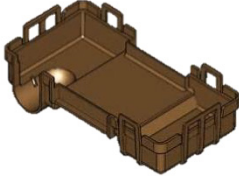
Description		PE Part Number	8 Digit Part Number	
Housing - Bus bar Subassembly 33272518	Housing	PE242429	33152669	
	Bus Bar	PE242426	33152670	
	Bus Bar	PE242427	33152672	
	Bus Bar	PE255013	33152673	
	Bus Bar	PE260273	33152674	
PLR		PE286899	33152676	
PLR		PE286900	33152677	
Wire Dress Cover		PE242430	33152678	
Wire Dress Cover		PE264537	33152679	

**Assembly / Disassembly Instructions**

**IR 25MY17**

PART NO. **23322679**

SHEET **3** OF **84**

ALL INFORMATION WITHIN ABOVE BORDER TO BE PRINTED EXACTLY AS SHOWN ON 8.5 x 11 WHITE 16 POUND NON-BOND RECYCLABLE PAPER. PRINT ON BOTH SIDES, EXCLUDING TEMPLATES. TO BE UNITIZED IN ACCORDANCE WITH GM SPECIFICATIONS.

DATE	REVISION	AUTH	DR
25MY17	Initial Release - Frank Lertz	N/A	

TITLE	PART NO.	SHEET	OF
<b>INSTALLATION INSTRUCTIONS Assembly / Disassembly Instructions</b>	<b>23322679</b>	<b>3</b>	<b>84</b>

### Cavity Numbering

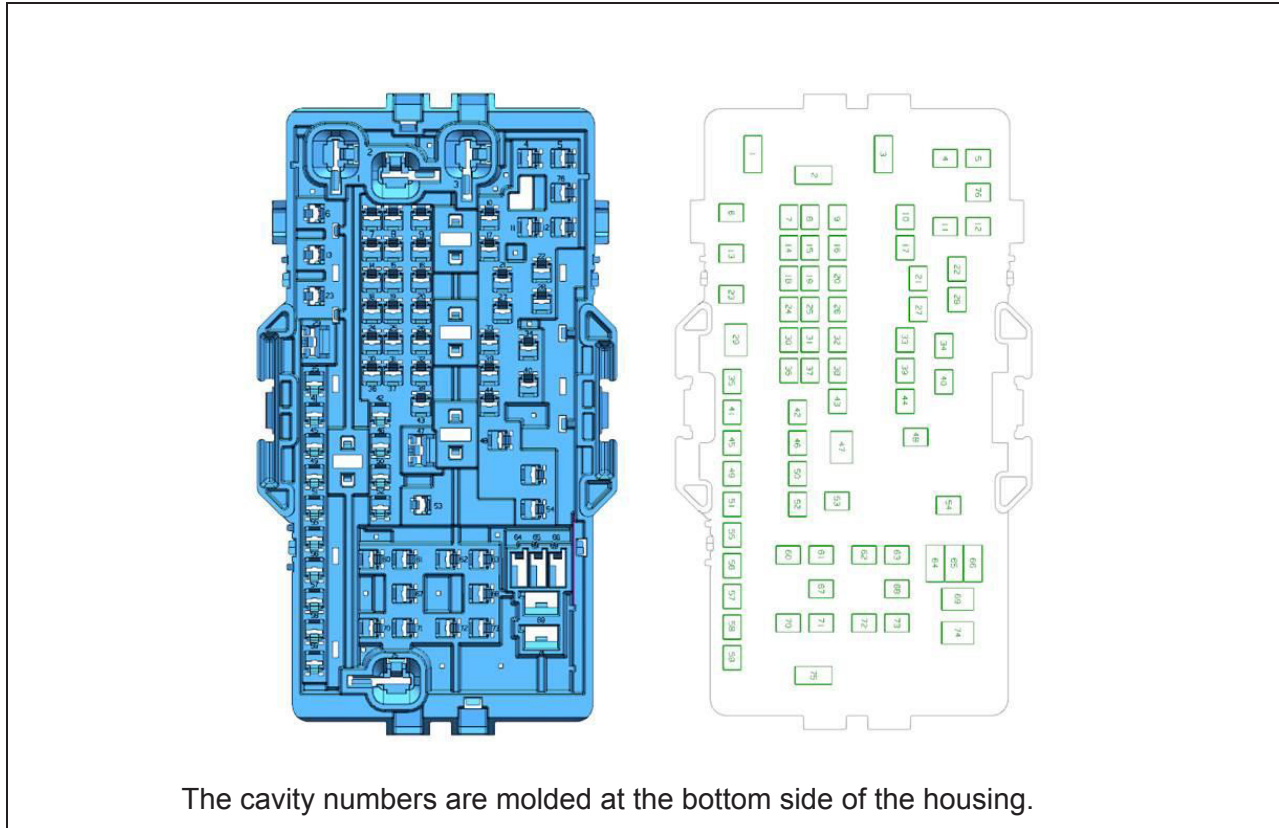

The cavity numbers are molded at the bottom side of the housing.

CAVITY INFORMATION			
CAVITY NAME	TERMINAL	DESCRIPTION	TYPICAL USE
1, 2, 3, 75	13979887	630 ASM F TERMINAL AG	BUSS BARS
4, 5, 7, 8, 9, 10, 11, 12, 14, 15, 16, 17, 18, 19, 20, 21, 22, 24, 25, 26, 27, 28, 30, 31, 32, 33, 34, 35, 36, 37, 38, 39, 40, 41, 42, 43, 44, 45, 46, 48, 49, 50, 51, 52, 54, 55, 56, 57, 58, 59, 60, 61, 62, 63, 67, 68, 70, 71, 72, 73, 76, 77	13849936	280 OCS F TERMINAL	RELAYS AND FUSES
6, 13, 23, 53	10725700	280 M TERMINAL	M-TYPE FUSE
29, 74	10725704	630 M TERMINAL	J-CASE FUSE
64, 65, 66, 69, 74	15344770	630 RELAY TERMINAL	LOGISTICS RELAY

Reference Chart for cavity type per cavity number

### Assembly / Disassembly Instructions

IR 25MY17

PART NO.

**23322679**

SHEET

**4** OF **84**

ALL INFORMATION WITHIN ABOVE BORDER TO BE PRINTED EXACTLY AS SHOWN ON 8.5 x 11 WHITE 16 POUND NON-BOND RECYCLABLE PAPER. PRINT ON BOTH SIDES, EXCLUDING TEMPLATES. TO BE UNITIZED IN ACCORDANCE WITH GM SPECIFICATIONS.

DATE	REVISION	AUTH	DR
25MY17	Initial Release - Frank Lertz	N/A	

TITLE
<b>INSTALLATION INSTRUCTIONS Assembly / Disassembly Instructions</b>
PART NO. <b>23322679</b> SHEET <b>4</b> OF <b>84</b>

### Terminal Insertion

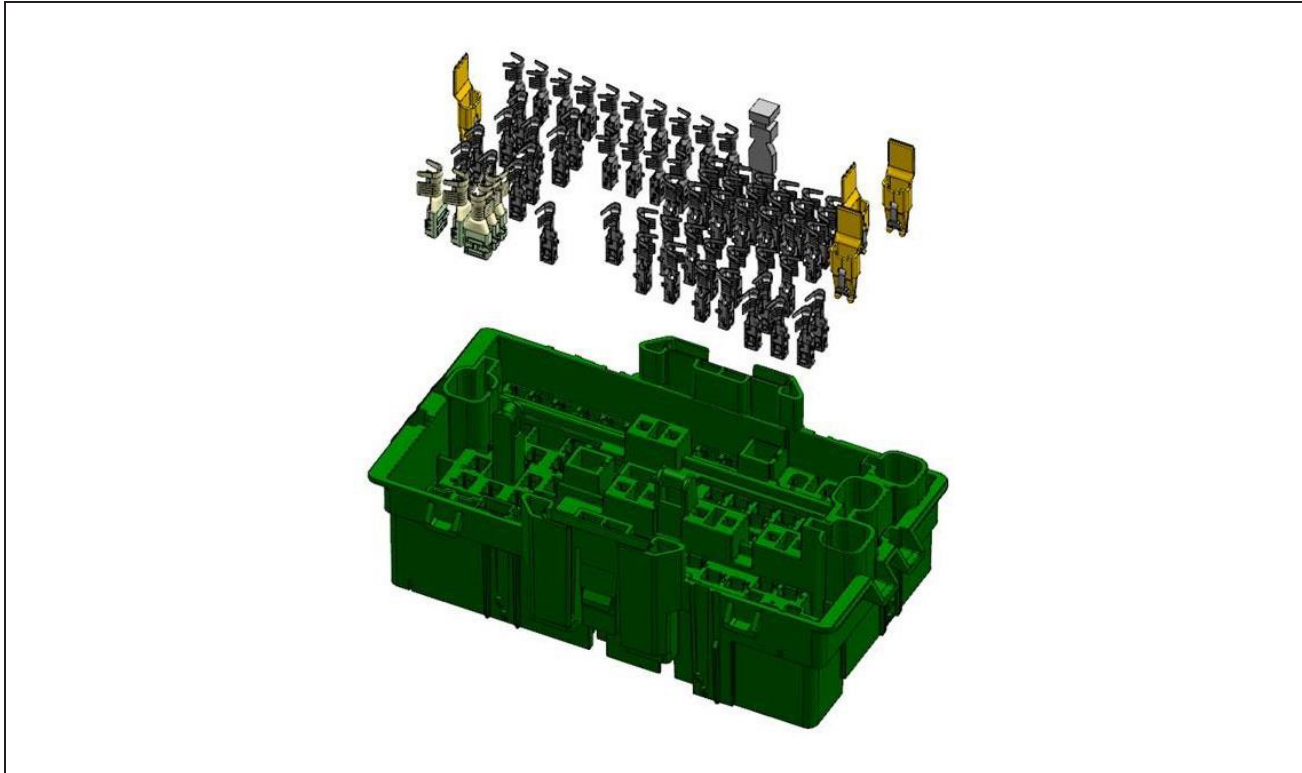

Insert the terminals by the bottom side in its corresponding cavity.  
(See Chart in previous page)

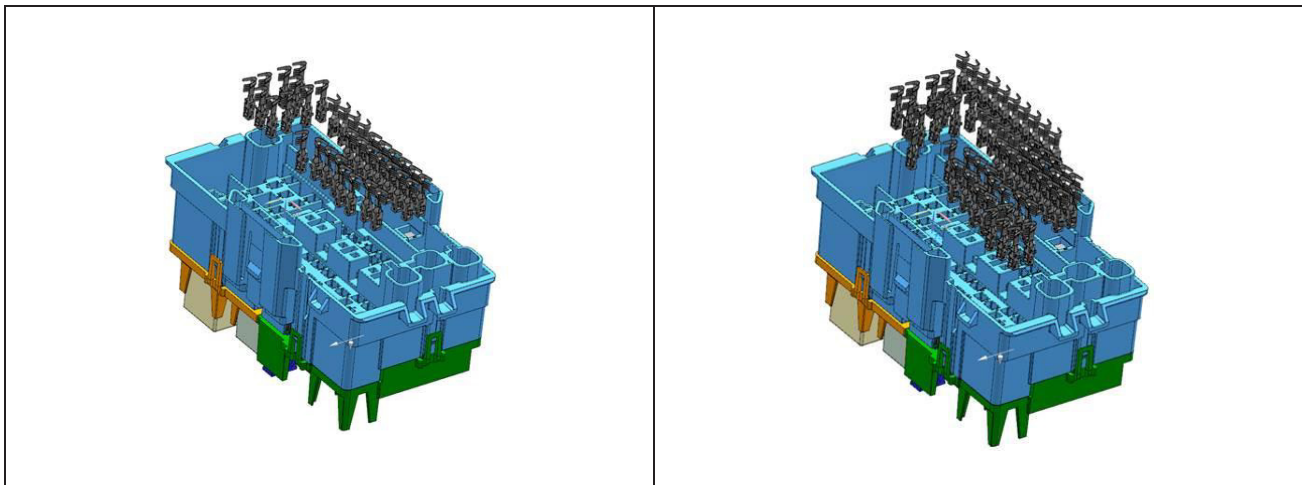

DATE	REVISION	AUTH	DR
25MY17	Initial Release - Frank Lertz	N/A	

TITLE	<b>INSTALLATION INSTRUCTIONS Assembly / Disassembly Instructions</b>		
PART NO.	<b>23322679</b>	SHEET	<b>5 OF 84</b>

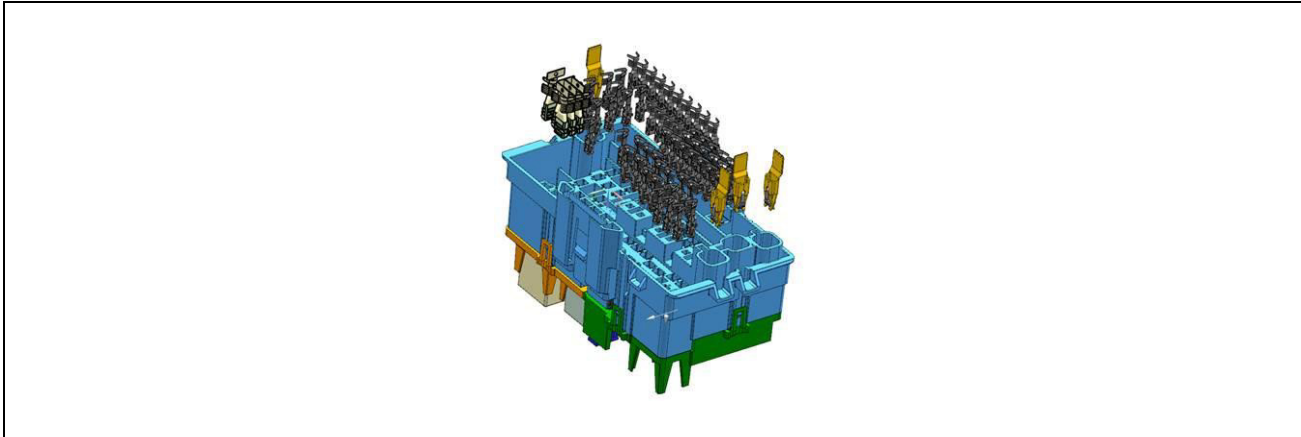

Begin terminal insertion at the center of the housing working out to the edges

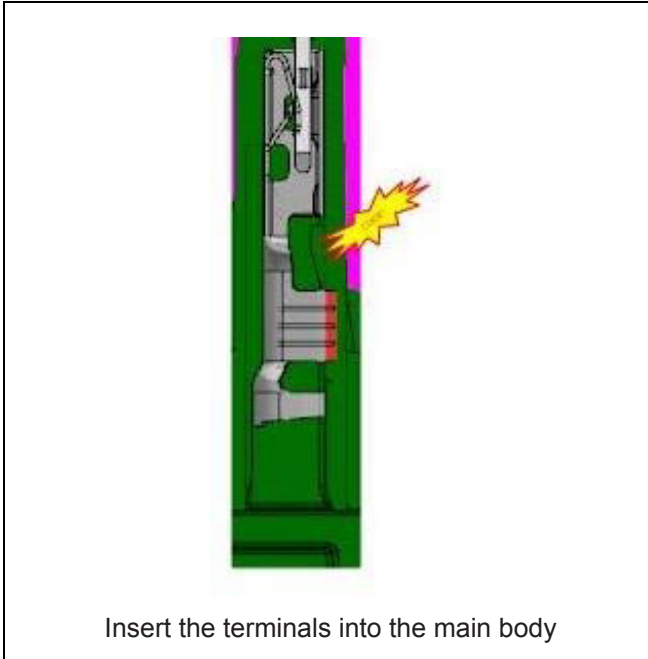

Insert the terminals into the main body

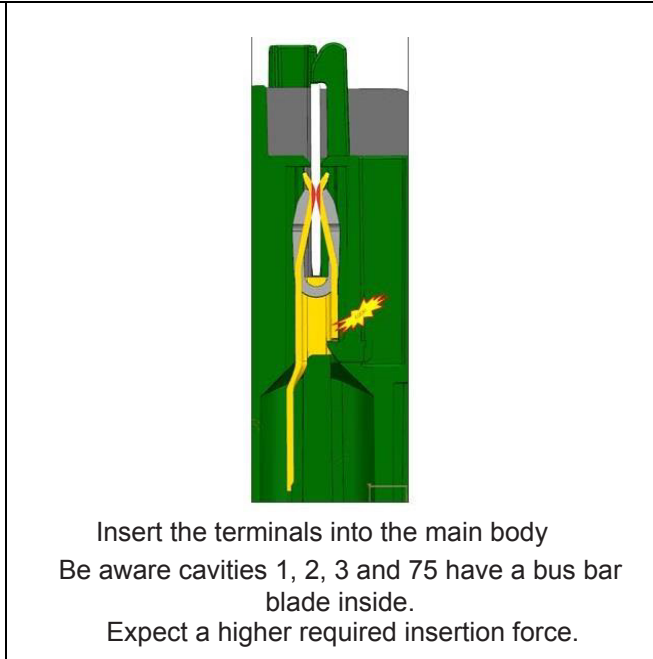

Insert the terminals into the main body  
Be aware cavities 1, 2, 3 and 75 have a bus bar blade inside.  
Expect a higher required insertion force.

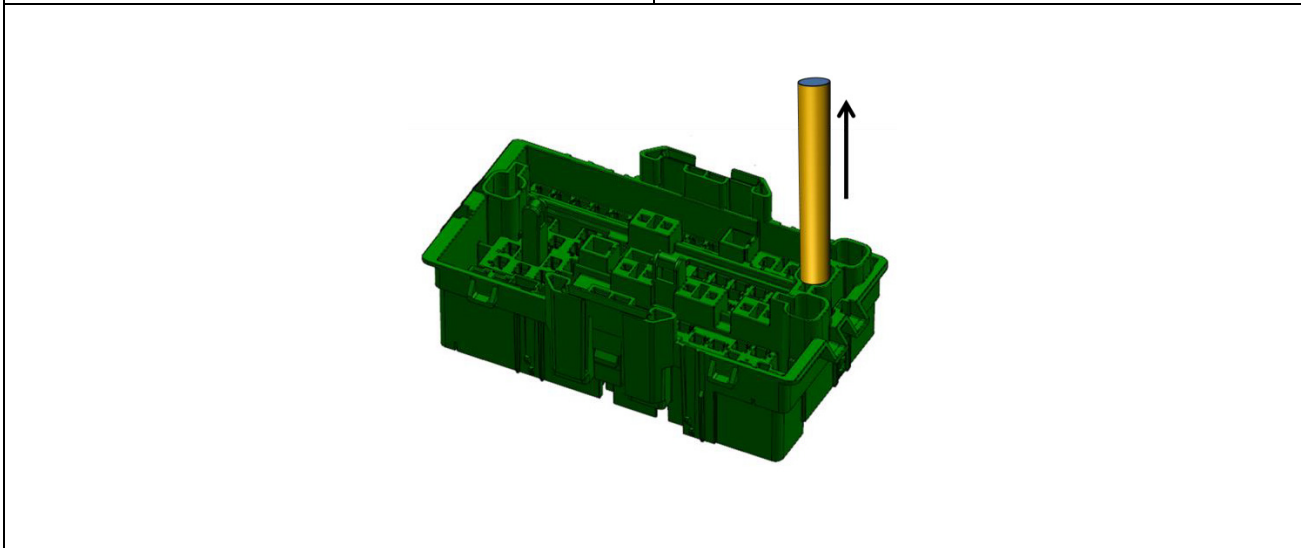

After every insertion, gently pull on the cable to verify the lock system

**Assembly / Disassembly Instructions**

**IR 25MY17**

PART NO.

**23322679**

SHEET

**6 OF 84**

ALL INFORMATION WITHIN ABOVE BORDER TO BE PRINTED EXACTLY AS SHOWN ON 8.5 x 11 WHITE 16 POUND NON-BOND RECYCLABLE PAPER. PRINT ON BOTH SIDES, EXCLUDING TEMPLATES. TO BE UNITIZED IN ACCORDANCE WITH GM SPECIFICATIONS.

DATE	REVISION	AUTH	DR
25MY17	Initial Release - Frank Lertz	N/A	

TITLE	PART NO.	SHEET	OF
<b>INSTALLATION INSTRUCTIONS Assembly / Disassembly Instructions</b>	<b>23322679</b>	<b>6</b>	<b>84</b>

**Place PLRs**

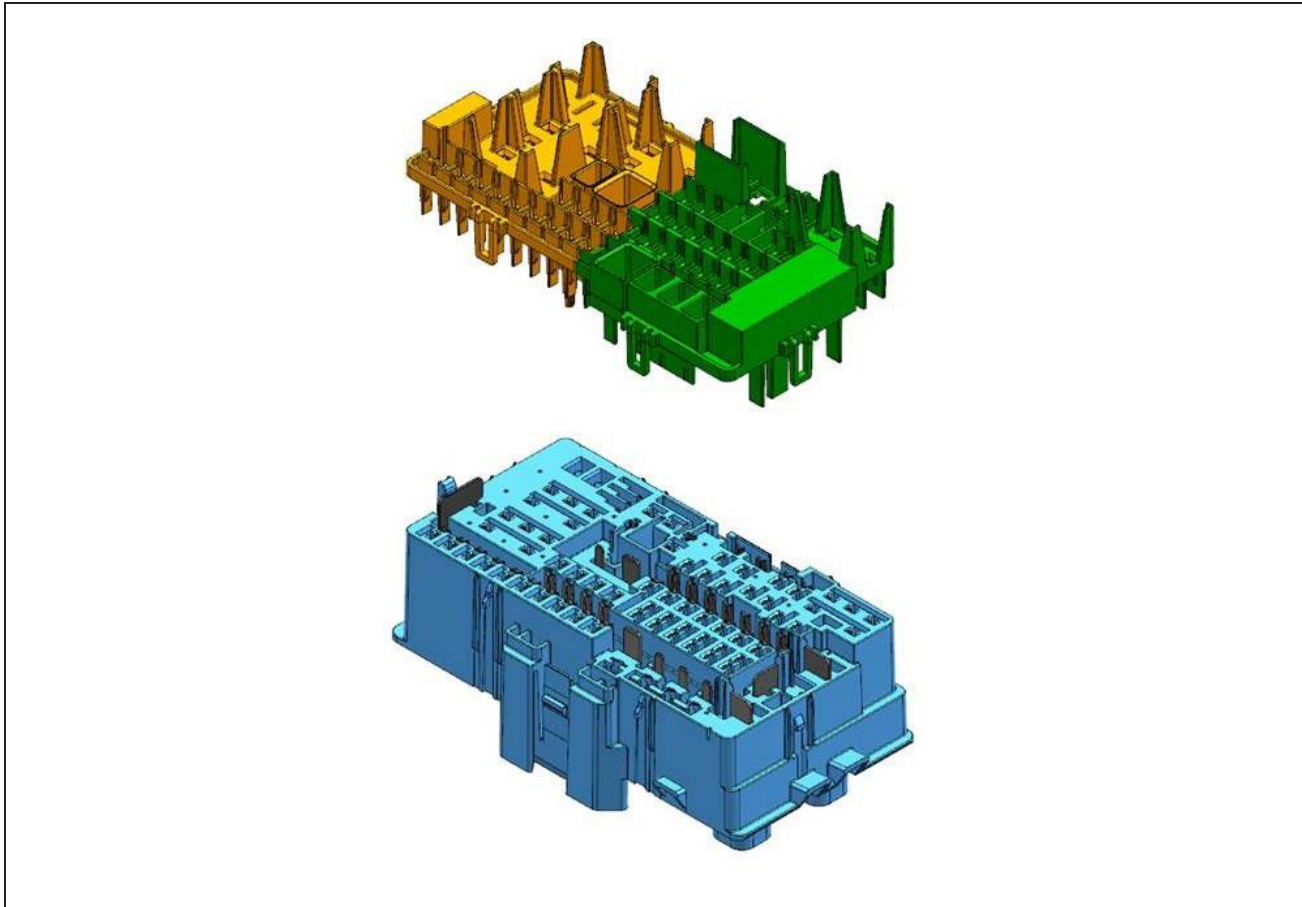

The PLRs (Two) can be assembled one after the other. There is no order of assembly.

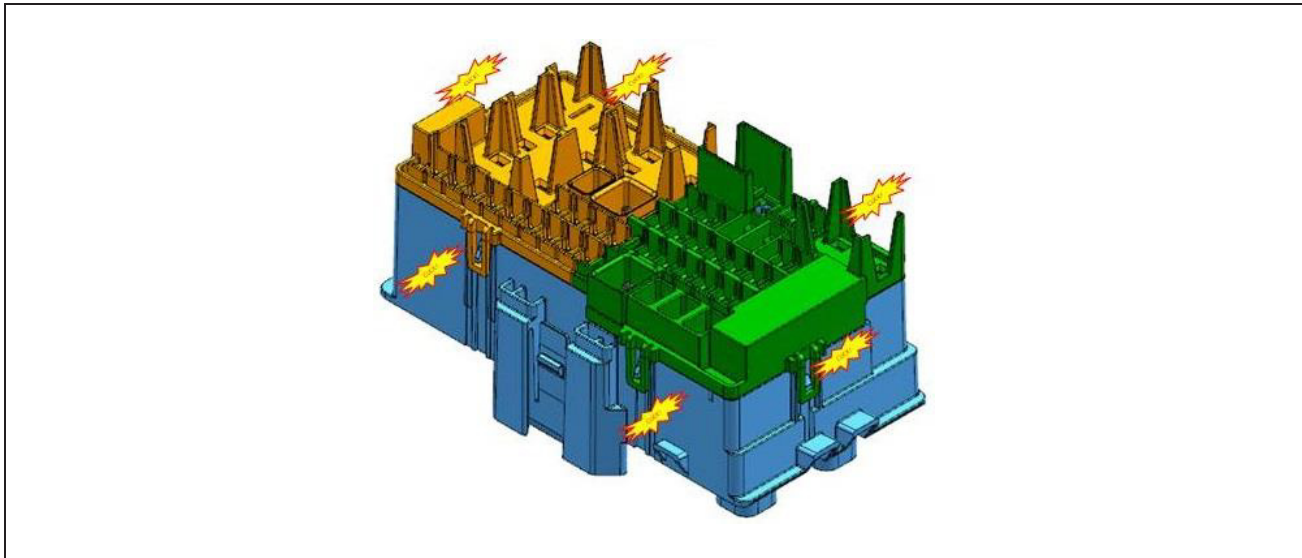

Press PLRs completely into the housing until a click is heard.  
Mechanical assist may be required.

**Assembly / Disassembly Instructions**

**IR 25MY17**

PART NO.

**23322679**

SHEET

**7 OF 84**

ALL INFORMATION WITHIN ABOVE BORDER TO BE PRINTED EXACTLY AS SHOWN ON 8.5 x 11 WHITE 16 POUND NON-BOND RECYCLABLE PAPER. PRINT ON BOTH SIDES, EXCLUDING TEMPLATES. TO BE UNITIZED IN ACCORDANCE WITH GM SPECIFICATIONS.

DATE	REVISION	AUTH	DR
25MY17	Initial Release - Frank Lertz	N/A	

TITLE	PART NO.	SHEET	OF
<b>INSTALLATION INSTRUCTIONS Assembly / Disassembly Instructions</b>	<b>23322679</b>	<b>7</b>	<b>84</b>

### Insert Devices

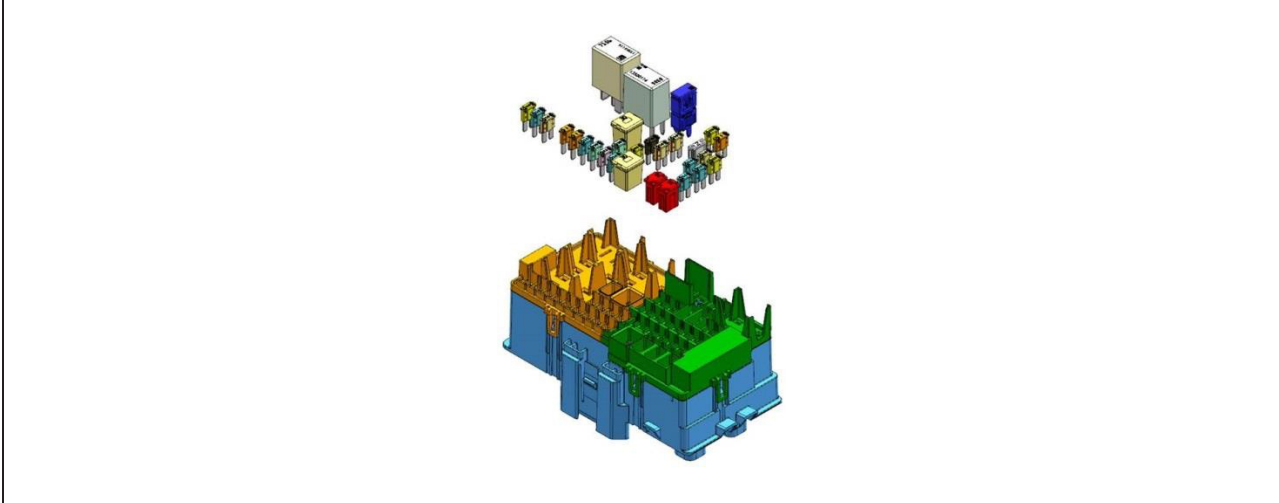

Insert fuses and relays as required per model.

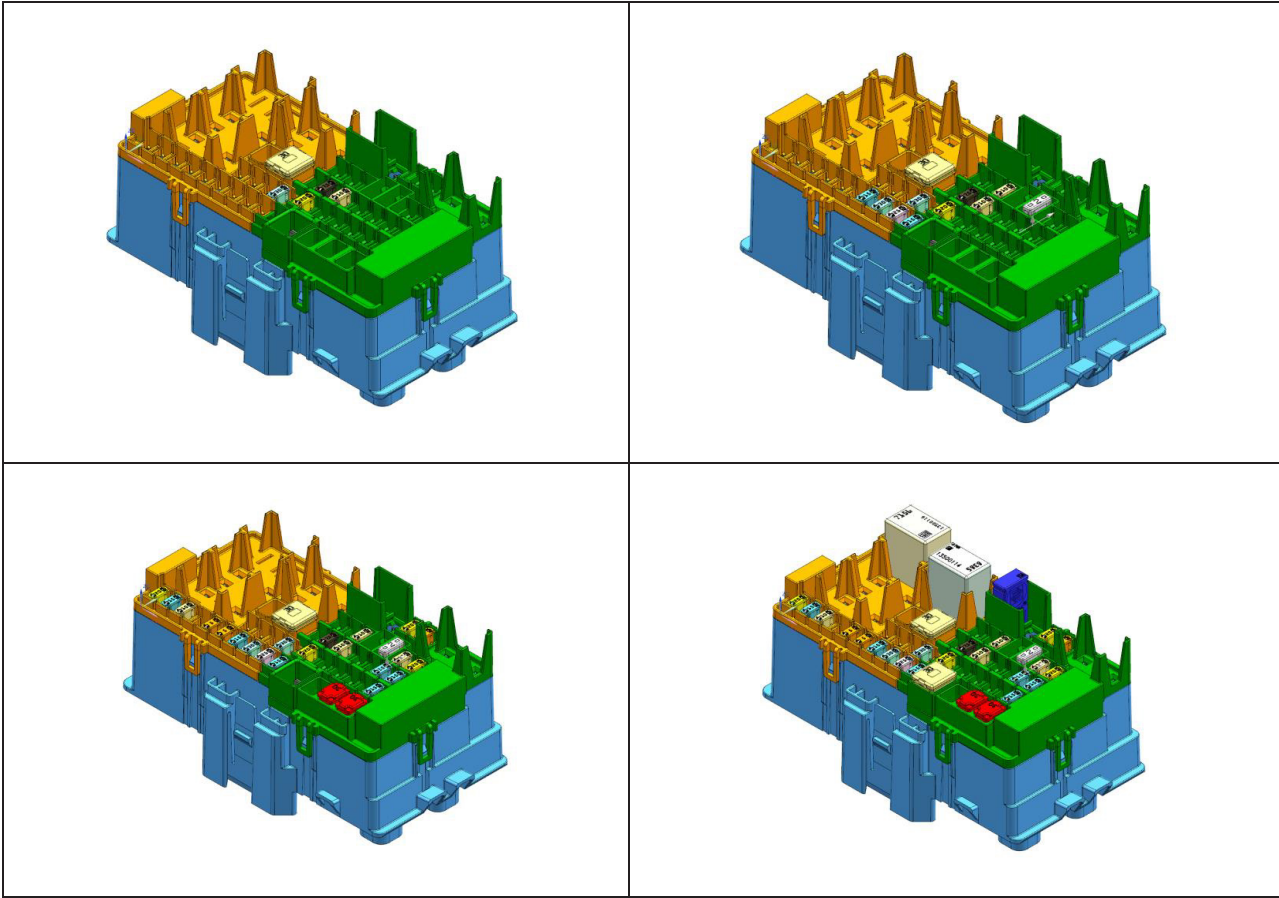

First insert the devices with the lowest profile and located in the center of the housing. Continue with the higher profile devices. As with the terminals, begin insertion at the center of the housing.

DATE	REVISION	AUTH	DR
25MY17	Initial Release - Frank Lertz	N/A	

TITLE	<b>INSTALLATION INSTRUCTIONS Assembly / Disassembly Instructions</b>		
PART NO.	<b>23322679</b>	SHEET	<b>8</b> OF <b>84</b>

**Place Wire Dress Cover**

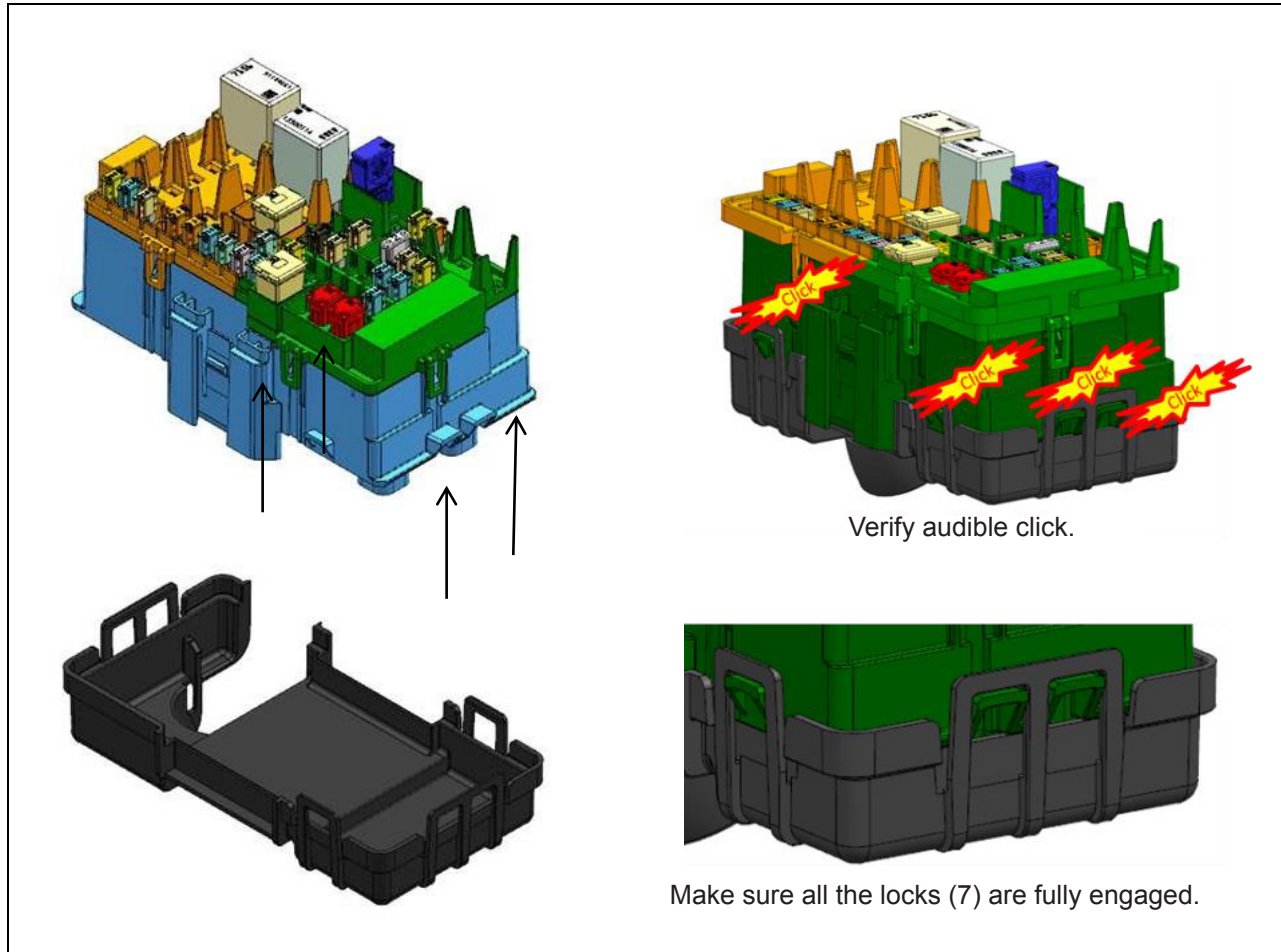

Bend the cables to the required harness routing position.

Attach the appropriate wire dress cover per the model and insert the wire tie through the slots provided.

DATE	REVISION	AUTH	DR
25MY17	Initial Release - Frank Lertz	N/A	

TITLE	<b>INSTALLATION INSTRUCTIONS Assembly / Disassembly Instructions</b>		
PART NO.	<b>23322679</b>	SHEET	<b>9</b> OF <b>84</b>

### Disassembly of the Electrical Center

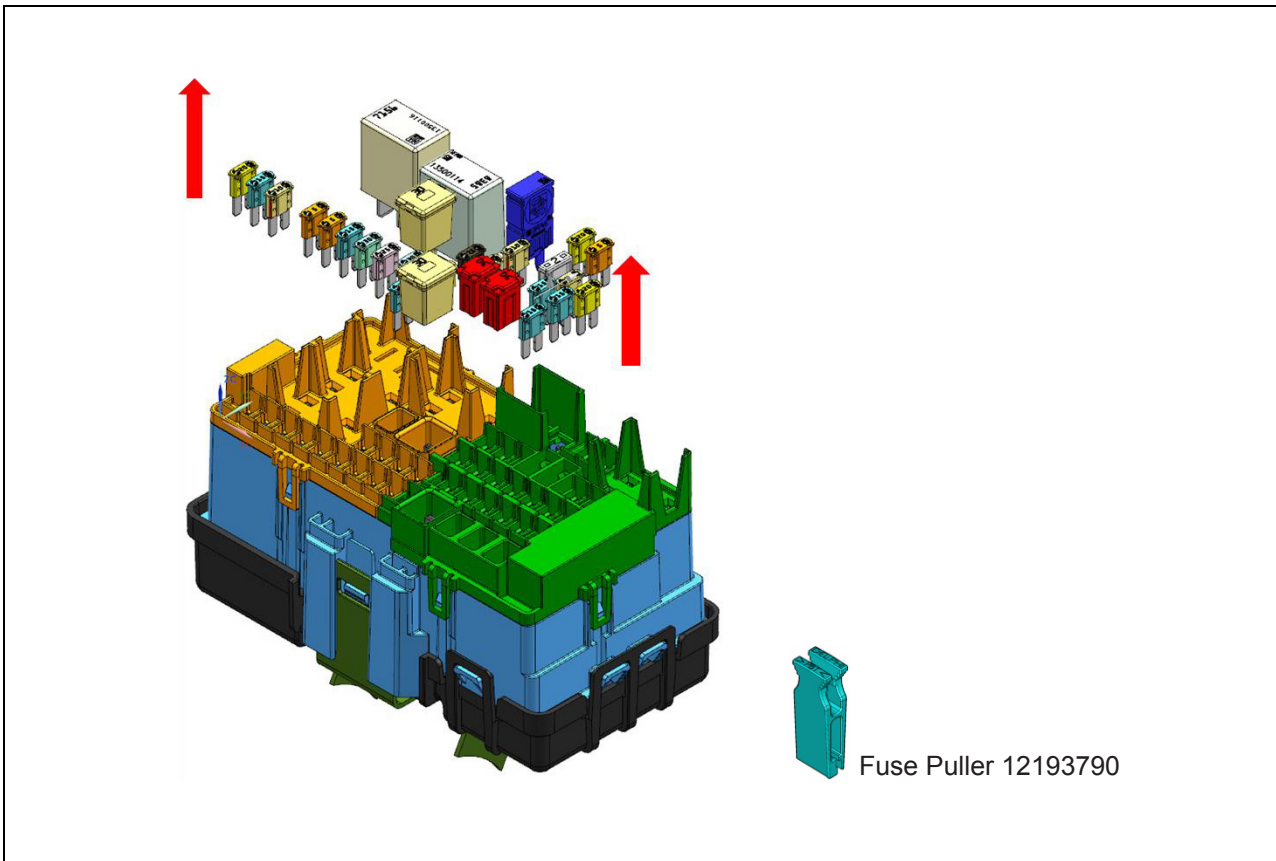

Remove all devices. Use Delphi fuse puller 12193790 (Recommended) to remove.

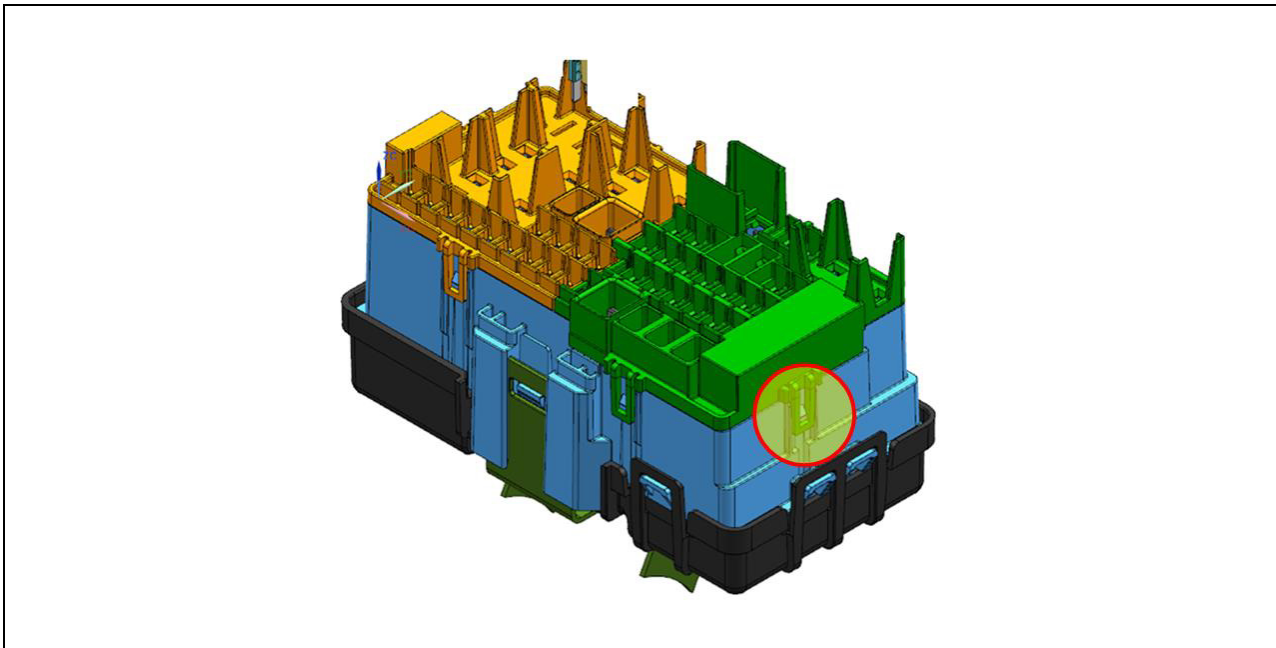

Lift the PLR locks.

Locks could be broken during operation. Have spare parts available.

DATE	REVISION	AUTH	DR
25MY17	Initial Release - Frank Lertz	N/A	

TITLE
<b>INSTALLATION INSTRUCTIONS Assembly / Disassembly Instructions</b>
PART NO. <b>23322679</b> SHEET <b>10 OF 84</b>

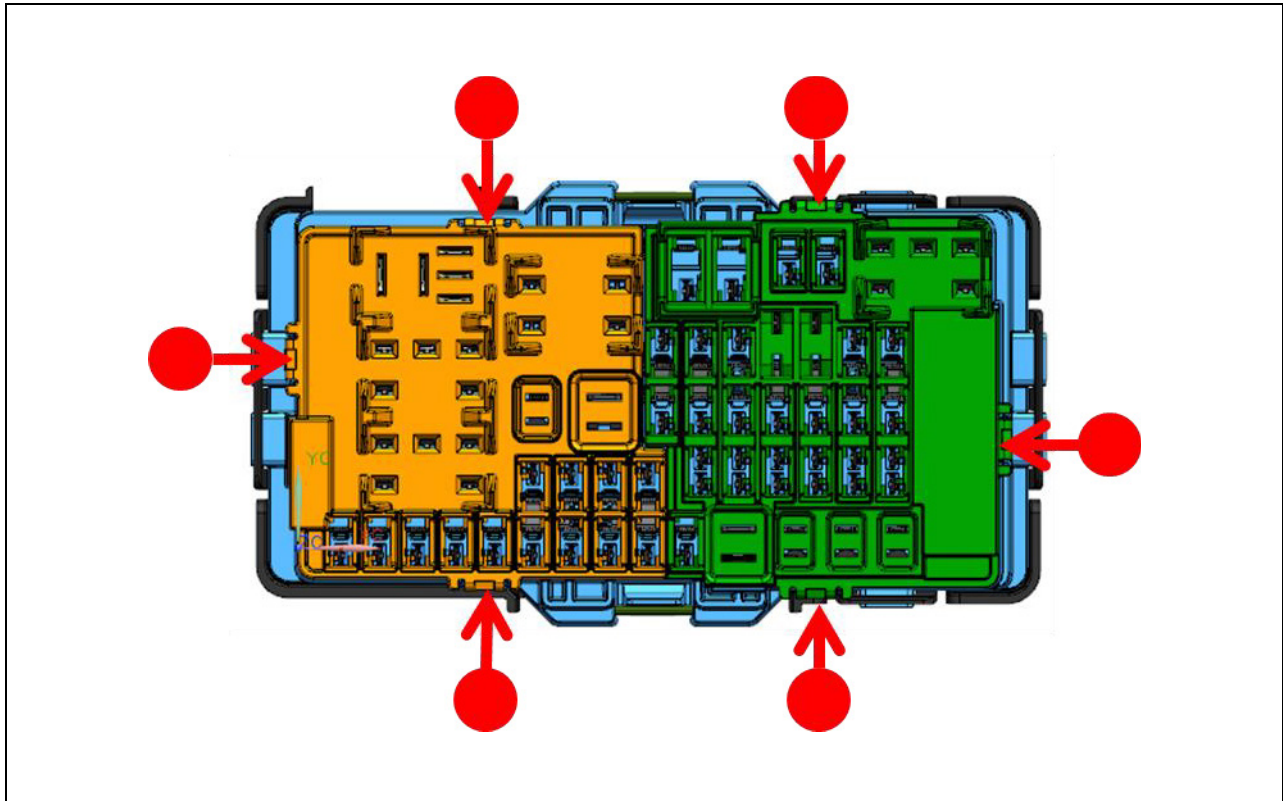

Each PLR can have 3 locks or more located in or nearby positions where the red circles and arrows show.

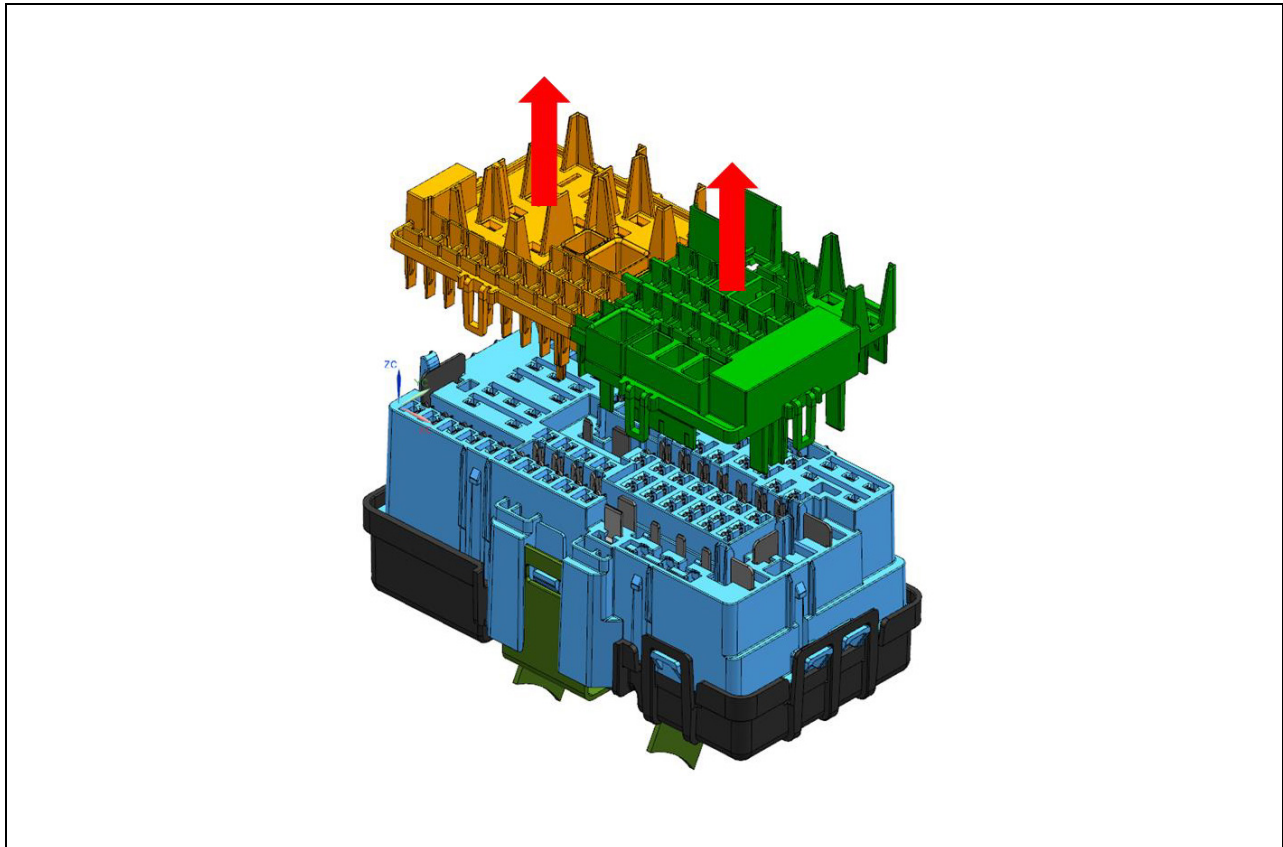

Remove the PLRs

**Assembly / Disassembly Instructions**

**IR 25MY17**

PART NO.

**23322679**

SHEET **11** OF **84**

ALL INFORMATION WITHIN ABOVE BORDER TO BE PRINTED EXACTLY AS SHOWN ON 8.5 x 11 WHITE 16 POUND NON-BOND RECYCLABLE PAPER. PRINT ON BOTH SIDES, EXCLUDING TEMPLATES. TO BE UNITIZED IN ACCORDANCE WITH GM SPECIFICATIONS.

DATE	REVISION	AUTH	DR
25MY17	Initial Release - Frank Lertz	N/A	

TITLE
<b>INSTALLATION INSTRUCTIONS Assembly / Disassembly Instructions</b>
PART NO. <b>23322679</b> SHEET <b>11</b> OF <b>84</b>

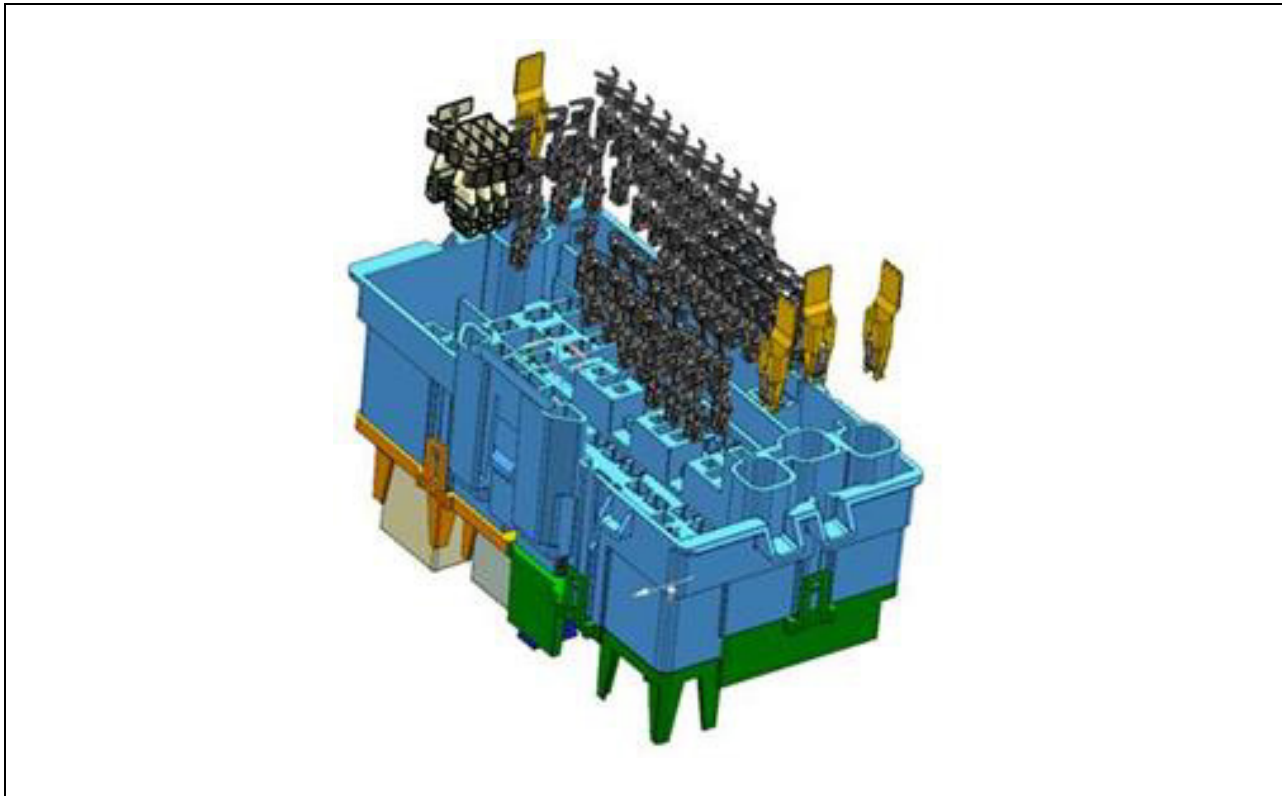

**Assembly / Disassembly Instructions**

**IR 25MY17**

PART NO.

**23322679**

SHEET **12** OF **84**

ALL INFORMATION WITHIN ABOVE BORDER TO BE PRINTED EXACTLY AS SHOWN ON 8.5 x 11 WHITE 16 POUND NON-BOND RECYCLABLE PAPER. PRINT ON BOTH SIDES, EXCLUDING TEMPLATES. TO BE UNITIZED IN ACCORDANCE WITH GM SPECIFICATIONS.

DATE	REVISION	AUTH	DR
25MY17	Initial Release - Frank Lertz	N/A	

TITLE
<b>INSTALLATION INSTRUCTIONS Assembly / Disassembly Instructions</b>
PART NO. <b>23322679</b> SHEET <b>12</b> OF <b>84</b>

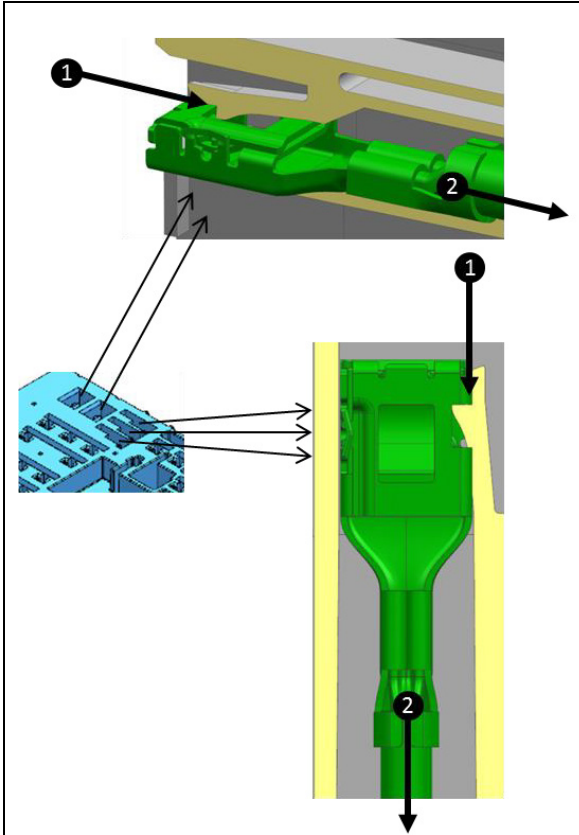

630F Terminal (Logistic Relay).

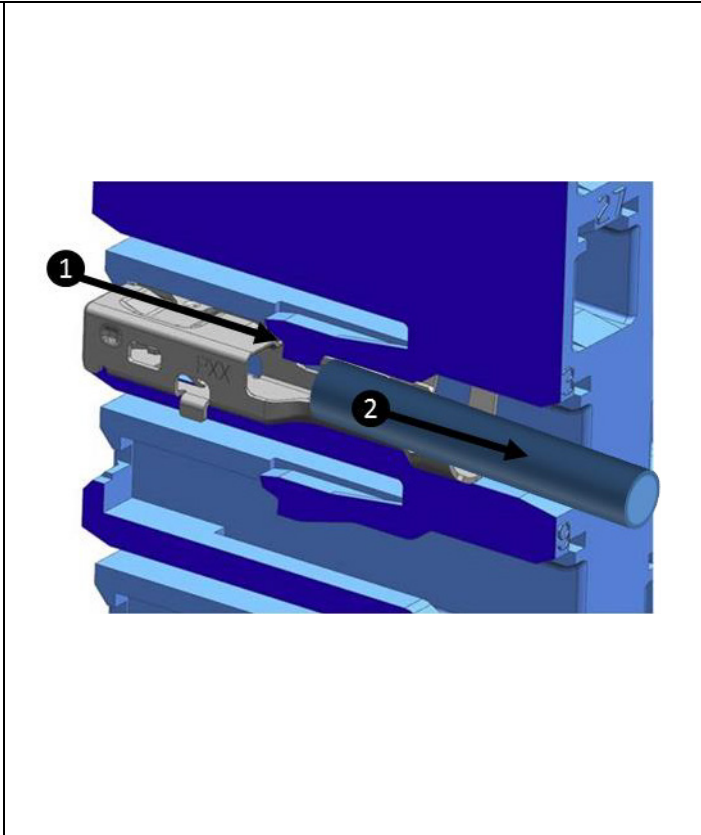

280F Terminal (Fuses, circuit Breakers and Relays).

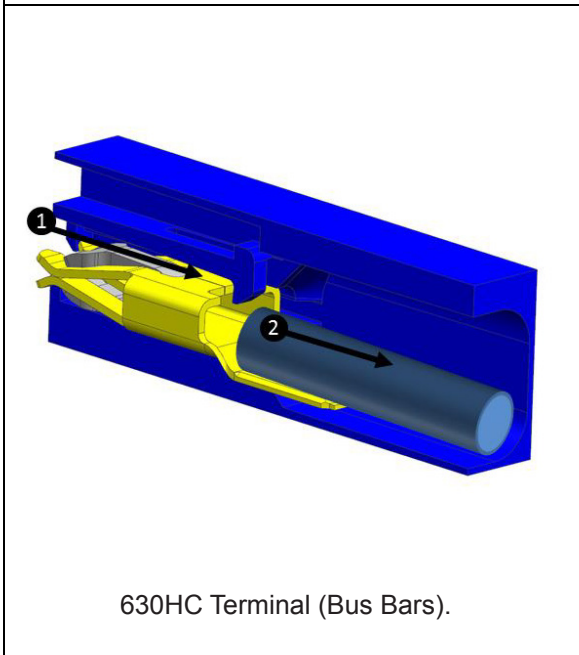

630HC Terminal (Bus Bars).

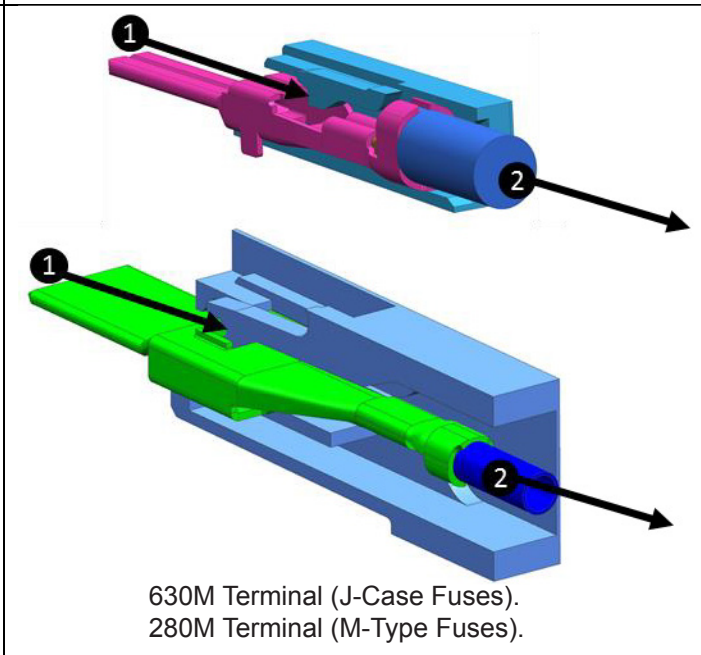

630M Terminal (J-Case Fuses).  
280M Terminal (M-Type Fuses).

**Operations Sequence**

1. Locate the flex lock feature in the plastic housing and lift it.
2. Pull the cable to extract the terminal.

**Assembly / Disassembly Instructions**

IR 25MY17

PART NO.

**23322679**

SHEET **13** OF **84**

ALL INFORMATION WITHIN ABOVE BORDER TO BE PRINTED EXACTLY AS SHOWN ON 8.5 x 11 WHITE 16 POUND NON-BOND RECYCLABLE PAPER. PRINT ON BOTH SIDES, EXCLUDING TEMPLATES. TO BE UNITIZED IN ACCORDANCE WITH GM SPECIFICATIONS.

DATE	REVISION	AUTH	DR
25MY17	Initial Release - Frank Lertz	N/A	

TITLE	PART NO.	SHEET
<b>INSTALLATION INSTRUCTIONS Assembly / Disassembly Instructions</b>	<b>23322679</b>	<b>13</b> OF <b>84</b>

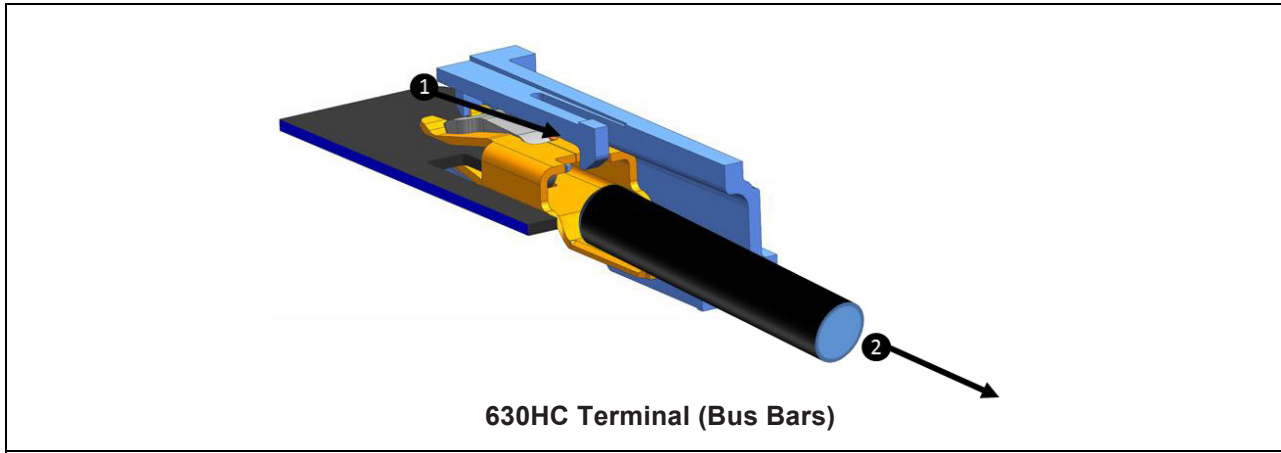

**630HC Terminal (Bus Bars)**

**Operations Sequence**

1. Locate the flex lock feature in the plastic housing and lift it.
2. Pull the cable to extract the terminal.

**Recommended Repair Tools**

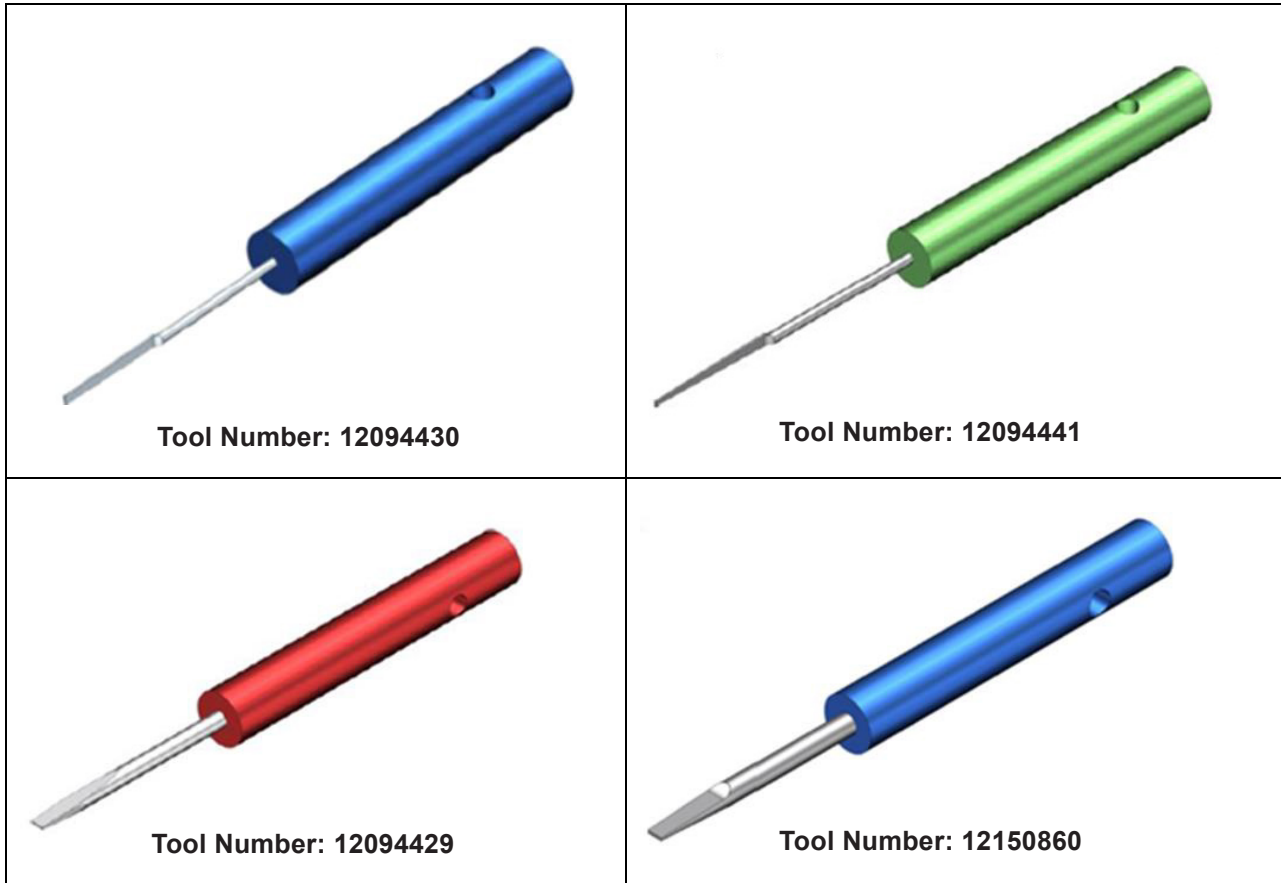

DATE	REVISION	AUTH	DR
25MY17	Initial Release - Frank Lertz	N/A	

**Instructions de montage - démontage**

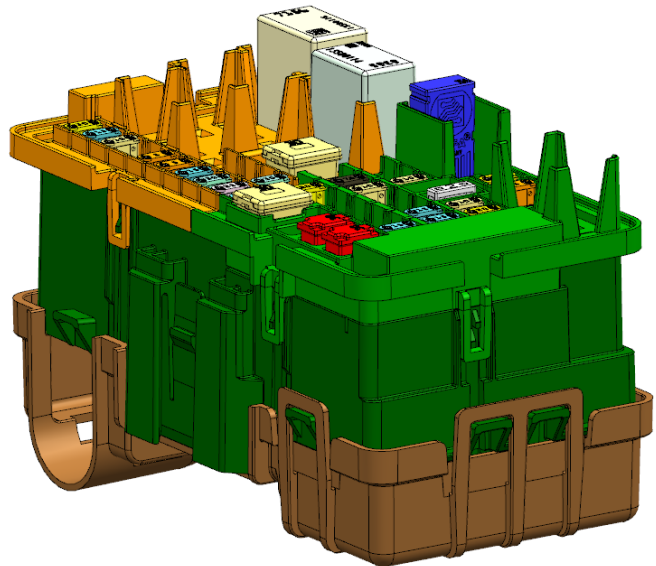
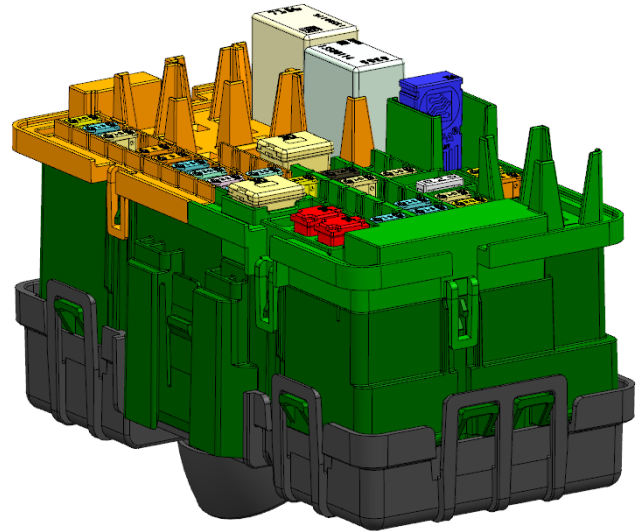

**Assembly / Disassembly Instructions**

**IR 25MY17**

PART NO.

**23322679**

SHEET

**15 OF 84**

ALL INFORMATION WITHIN ABOVE BORDER TO BE PRINTED EXACTLY AS SHOWN ON 8.5 x 11 WHITE 16 POUND NON-BOND RECYCLABLE PAPER. PRINT ON BOTH SIDES, EXCLUDING TEMPLATES. TO BE UNITIZED IN ACCORDANCE WITH GM SPECIFICATIONS.

DATE	REVISION	AUTH	DR
25MY17	Initial Release - Frank Lertz	N/A	

TITLE	<b>INSTALLATION INSTRUCTIONS Assembly / Disassembly Instructions</b>		
PART NO.	<b>23322679</b>	SHEET	<b>15 OF 84</b>

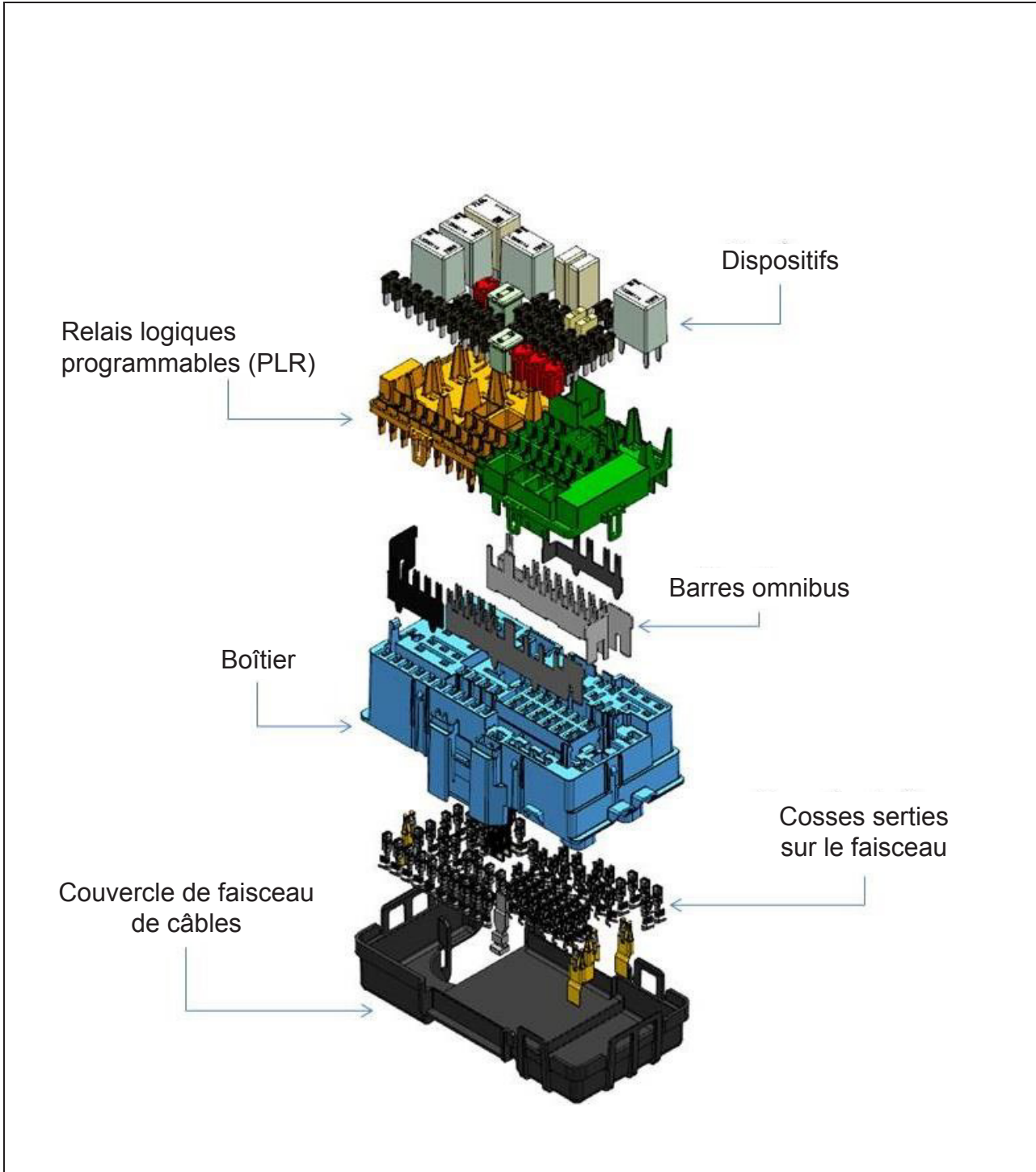

**Vue éclatée**



DATE	REVISION	AUTH	DR
25MY17	Initial Release - Frank Lertz	N/A	

TITLE
<b>INSTALLATION INSTRUCTIONS</b>
<b>Assembly / Disassembly Instructions</b>
PART NO. <b>23322679</b>
SHEET <b>16</b> OF <b>84</b>

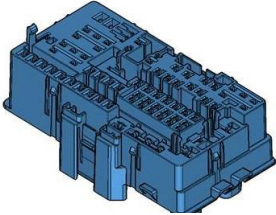
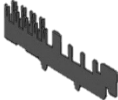
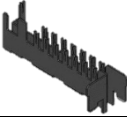
**Nomenclature**

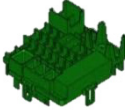
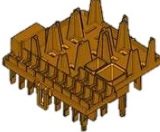
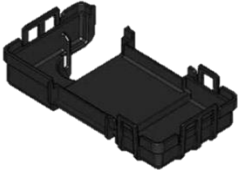
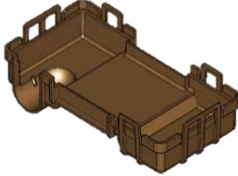
Description		Numéro de pièce PE	Numéro de pièces à 8 chiffres	
Boîtier - Barre omnibus Sous-ensemble 33272518	Boîtier	PE242429	33152669	
	Barre omnibus	PE242426	33152670	
	Barre omnibus	PE242427	33152672	
	Barre omnibus	PE255013	33152673	
	Barre omnibus	PE260273	33152674	
PLR		PE286899	33152676	
PLR		PE286900	33152677	
Couvercle de faisceau de câbles		PE242430	33152678	
Couvercle de faisceau de câbles		PE264537	33152679	

**Assembly / Disassembly Instructions**
**IR 25MY17**

PART NO.

**23322679**

 SHEET **17** OF **84**

ALL INFORMATION WITHIN ABOVE BORDER TO BE PRINTED EXACTLY AS SHOWN ON 8.5 x 11 WHITE 16 POUND NON-BOND RECYCLABLE PAPER. PRINT ON BOTH SIDES, EXCLUDING TEMPLATES. TO BE UNITIZED IN ACCORDANCE WITH GM SPECIFICATIONS.

DATE	REVISION	AUTH	DR
25MY17	Initial Release - Frank Lertz	N/A	

TITLE

**INSTALLATION INSTRUCTIONS  
Assembly / Disassembly Instructions**

PART NO.

**23322679**

SHEET

**17** OF **84**

**Numérotation des cavités**

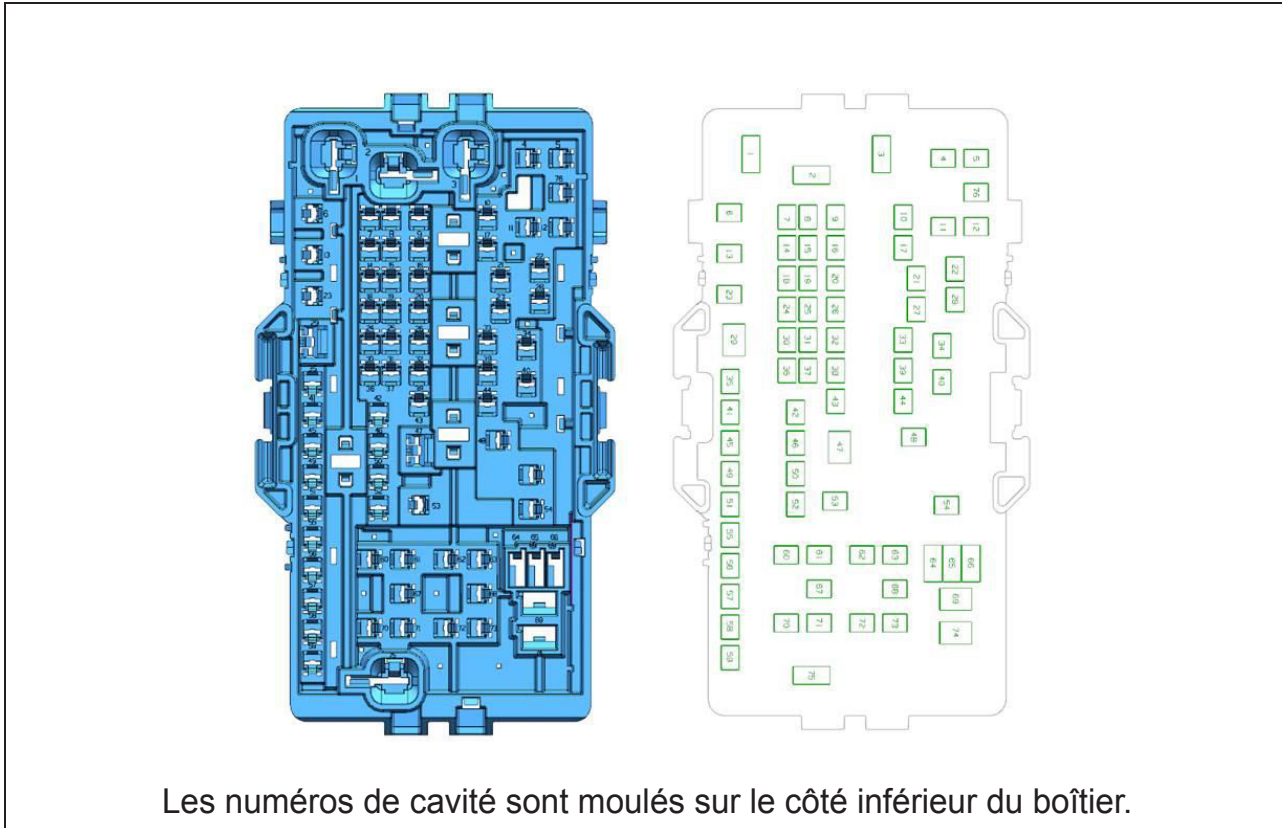

Les numéros de cavité sont moulés sur le côté inférieur du boîtier.

CAVITY INFORMATION			
CAVITY NAME	TERMINAL	DESCRIPTION	TYPICAL USE
1, 2, 3, 75	13979887	630 ASM F TERMINAL AG	BUSS BARS
4, 5, 7, 8, 9, 10, 11, 12, 14, 15, 16, 17, 18, 19, 20, 21, 22, 24, 25, 26, 27, 28, 30, 31, 32, 33, 34, 35, 36, 37, 38, 39, 40, 41, 42, 43, 44, 45, 46, 48, 49, 50, 51, 52, 54, 55, 56, 57, 58, 59, 60, 61, 62, 63, 67, 68, 70, 71, 72, 73, 76, 77	13849936	280 OCS F TERMINAL	RELAYS AND FUSES
6, 13, 23, 53	10725700	280 M TERMINAL	M-TYPE FUSE
29, 74	10725704	630 M TERMINAL	J-CASE FUSE
64, 65, 66, 69, 74	15344770	630 RELAY TERMINAL	LOGISTICS RELAY

Tableau de référence de type cavité par numéro de cavité

DATE	REVISION	AUTH	DR
25MY17	Initial Release - Frank Lertz	N/A	

**Insertion des cosses**

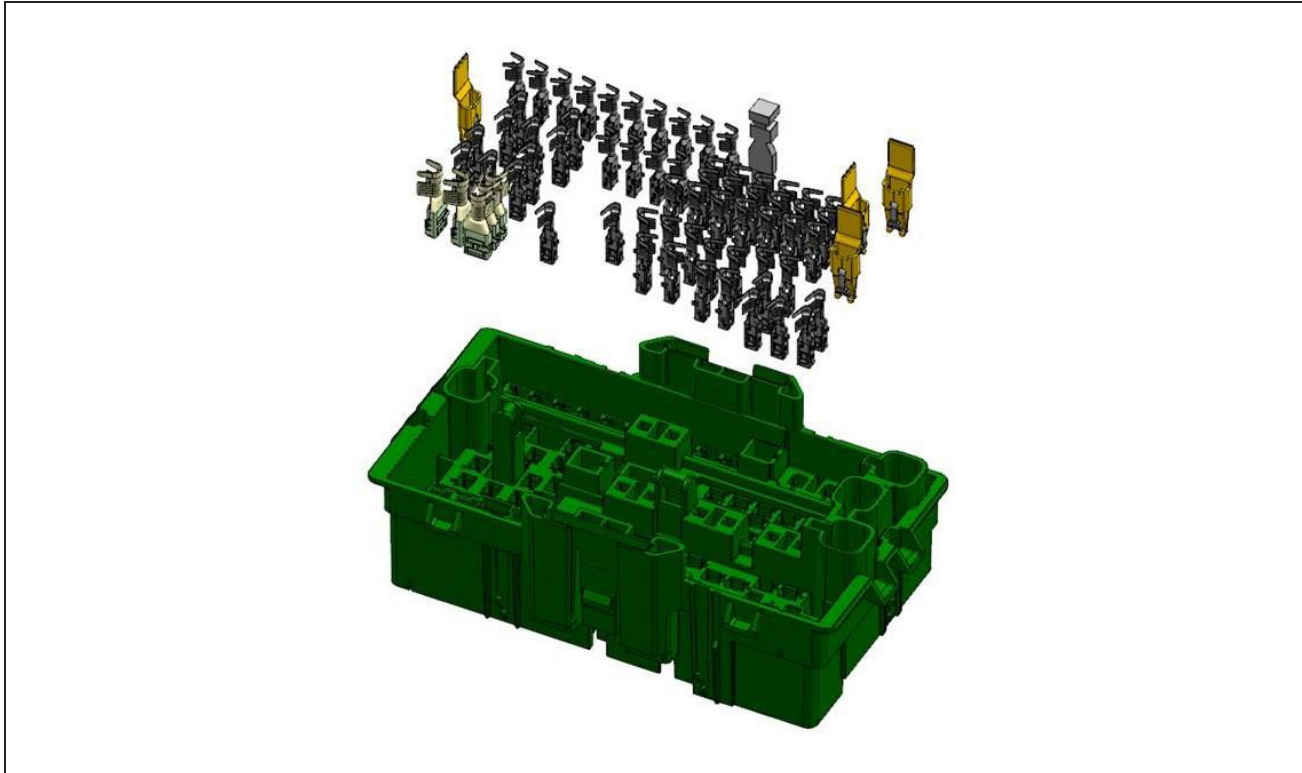

Insérer chaque cosse par le côté inférieur, dans la cavité qui lui est affectée.  
(Voir le tableau à la page précédente)

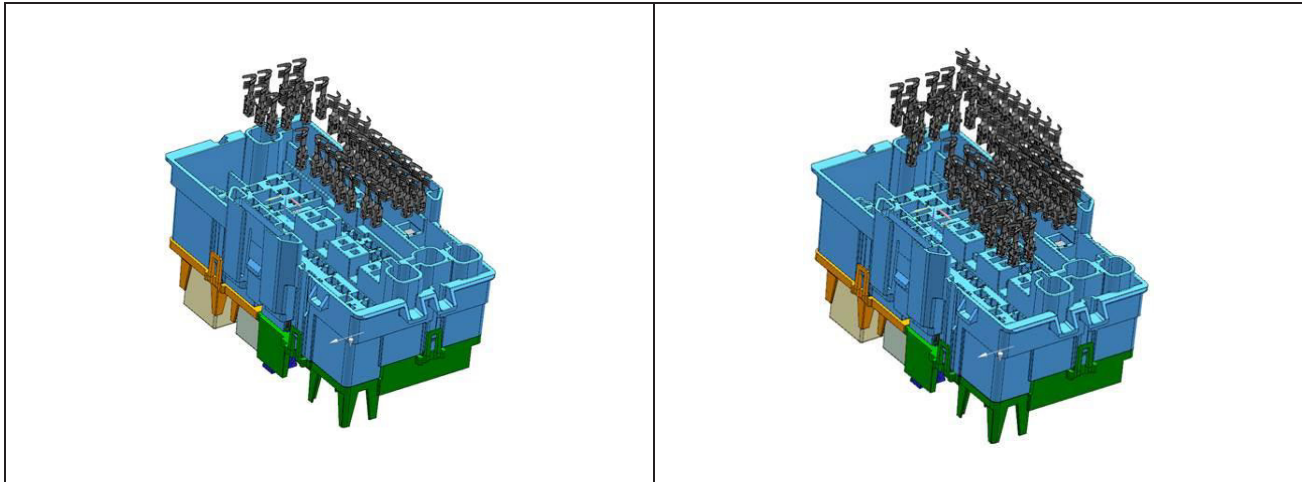

DATE	REVISION	AUTH	DR
25MY17	Initial Release - Frank Lertz	N/A	

TITLE	<b>INSTALLATION INSTRUCTIONS Assembly / Disassembly Instructions</b>		
PART NO.	<b>23322679</b>	SHEET	<b>19 OF 84</b>

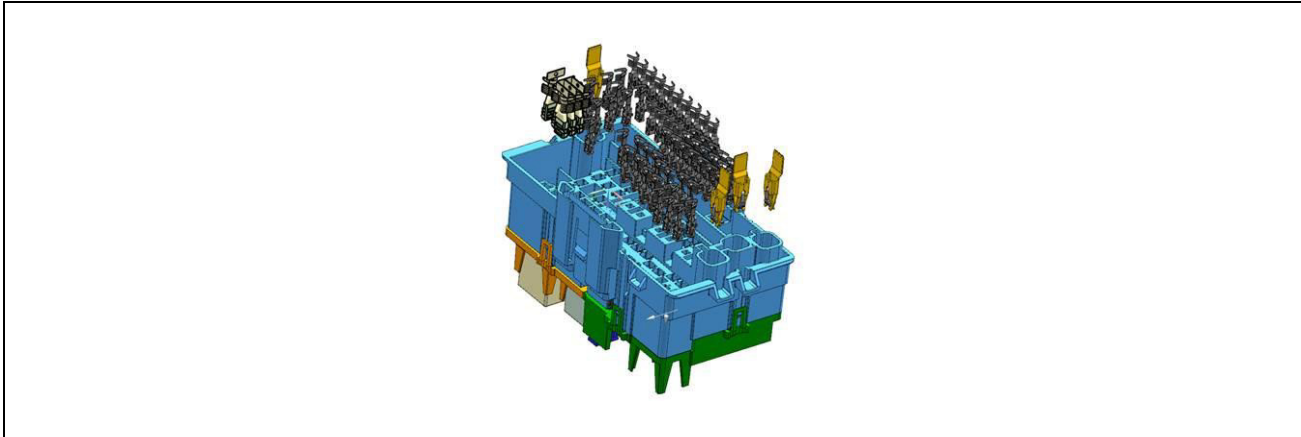

Commencer l'insertion des cosses par le centre du boîtier pour terminer vers les bords

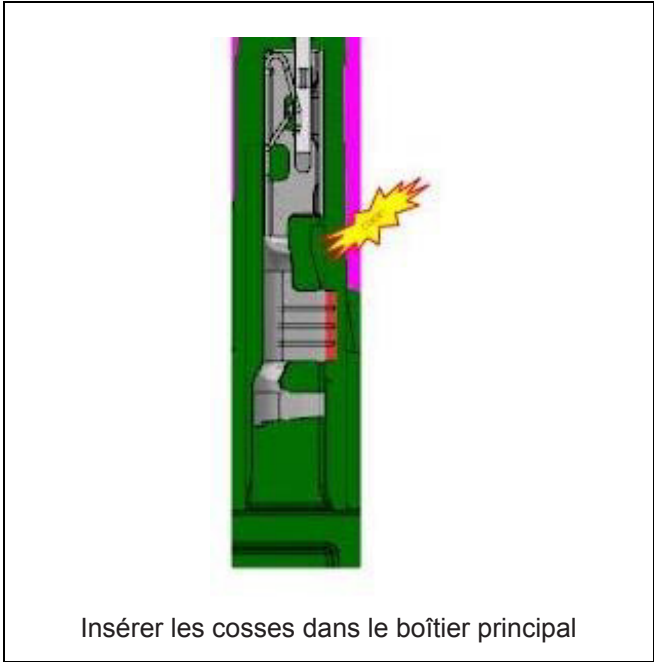

Insérer les cosses dans le boîtier principal

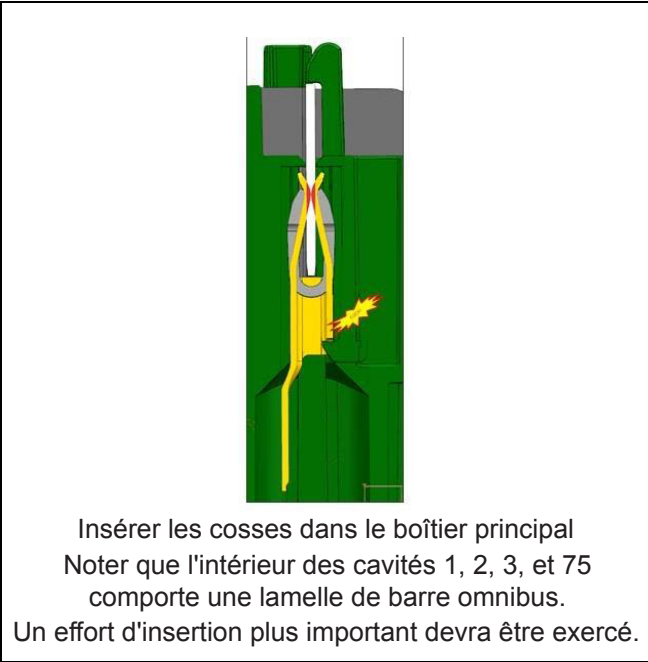

Insérer les cosses dans le boîtier principal  
 Noter que l'intérieur des cavités 1, 2, 3, et 75 comporte une lamelle de barre omnibus.  
 Un effort d'insertion plus important devra être exercé.

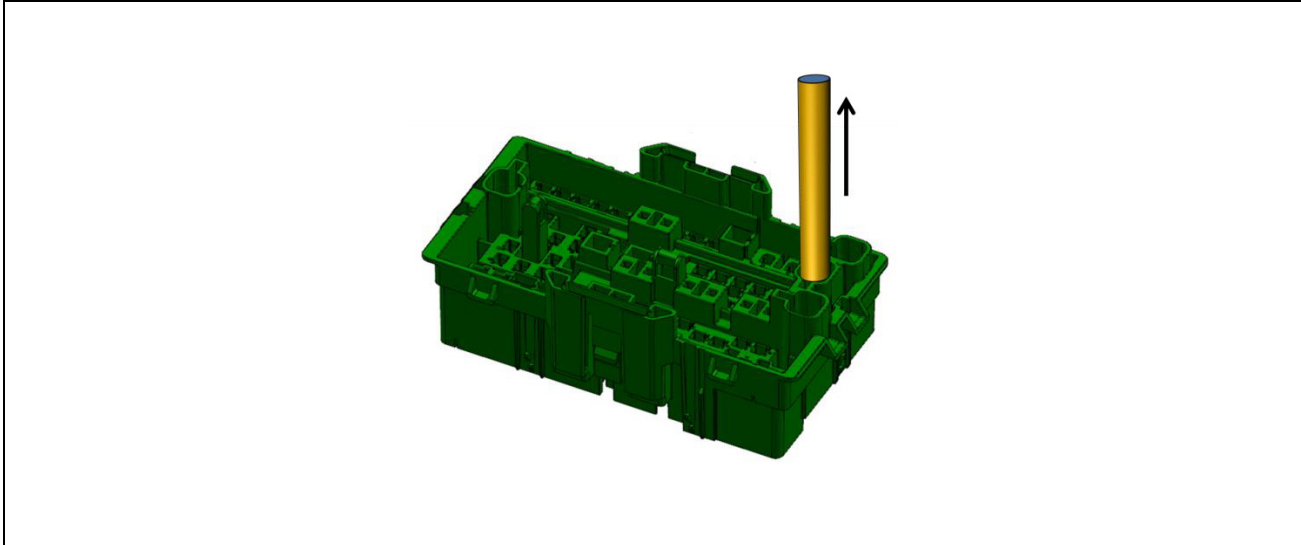

Après chaque insertion, tirer délicatement sur le câble pour en vérifier le mécanisme de verrouillage

**Assembly / Disassembly Instructions**

**IR 25MY17**

PART NO. **23322679**

SHEET **20** OF **84**

ALL INFORMATION WITHIN ABOVE BORDER TO BE PRINTED EXACTLY AS SHOWN ON 8.5 x 11 WHITE 16 POUND NON-BOND RECYCLABLE PAPER. PRINT ON BOTH SIDES, EXCLUDING TEMPLATES. TO BE UNITIZED IN ACCORDANCE WITH GM SPECIFICATIONS.

DATE	REVISION	AUTH	DR
25MY17	Initial Release - Frank Lertz	N/A	

TITLE	<b>INSTALLATION INSTRUCTIONS Assembly / Disassembly Instructions</b>		
PART NO.	<b>23322679</b>	SHEET	<b>20</b> OF <b>84</b>

**Placer les PLR**

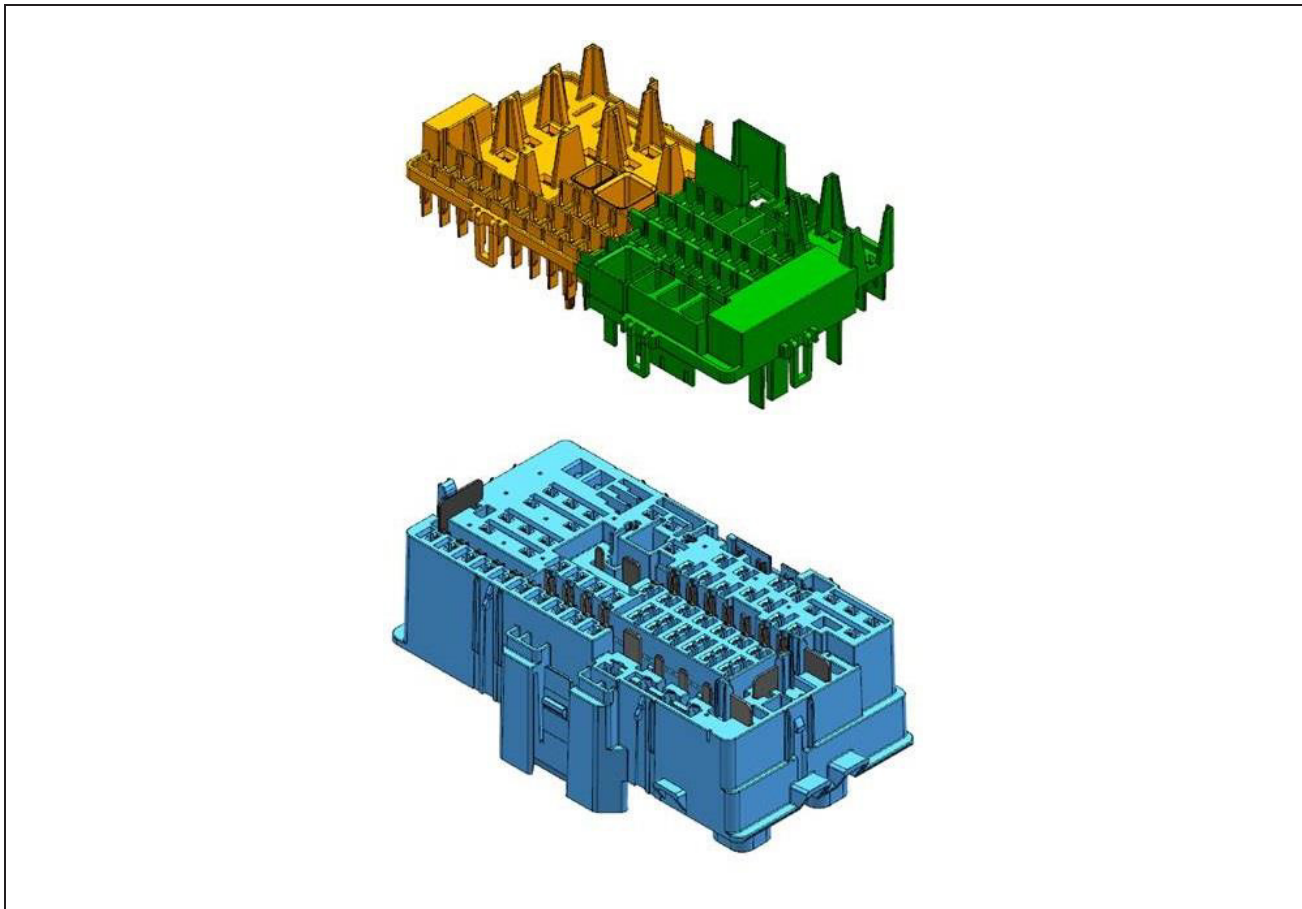

Les PLR (deux) peuvent être assemblés l'un après l'autre. L'ordre d'assemblage est indifférent.

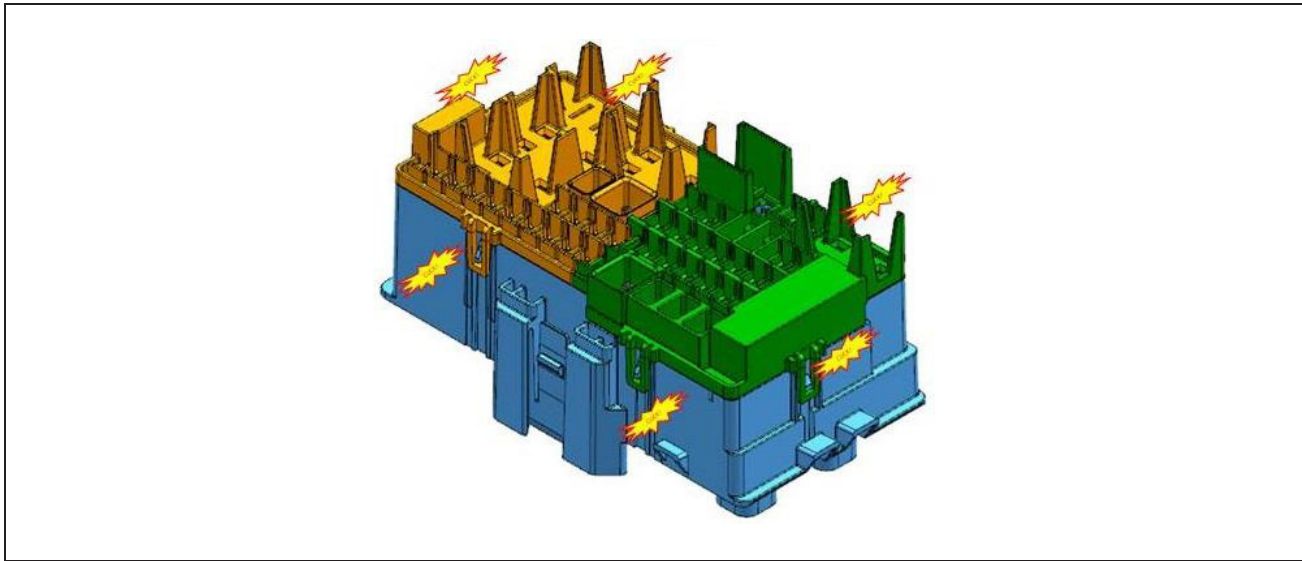

Appuyer sur les PLR jusqu'à entendre un déclic confirmant leur verrouillage, un outil d'aide peut s'avérer nécessaire.

DATE	REVISION	AUTH	DR
25MY17	Initial Release - Frank Lertz	N/A	

TITLE	PART NO.	SHEET	OF
<b>INSTALLATION INSTRUCTIONS Assembly / Disassembly Instructions</b>	<b>23322679</b>	<b>21</b>	<b>84</b>

**Insérer les dispositifs**

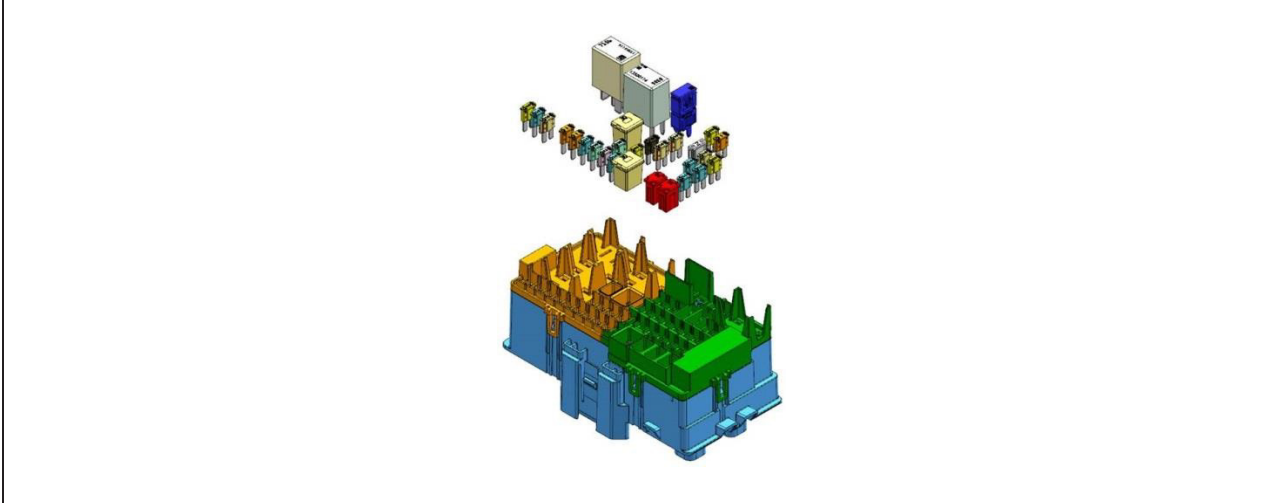

Insérer les fusibles et relais selon les besoins par modèle.

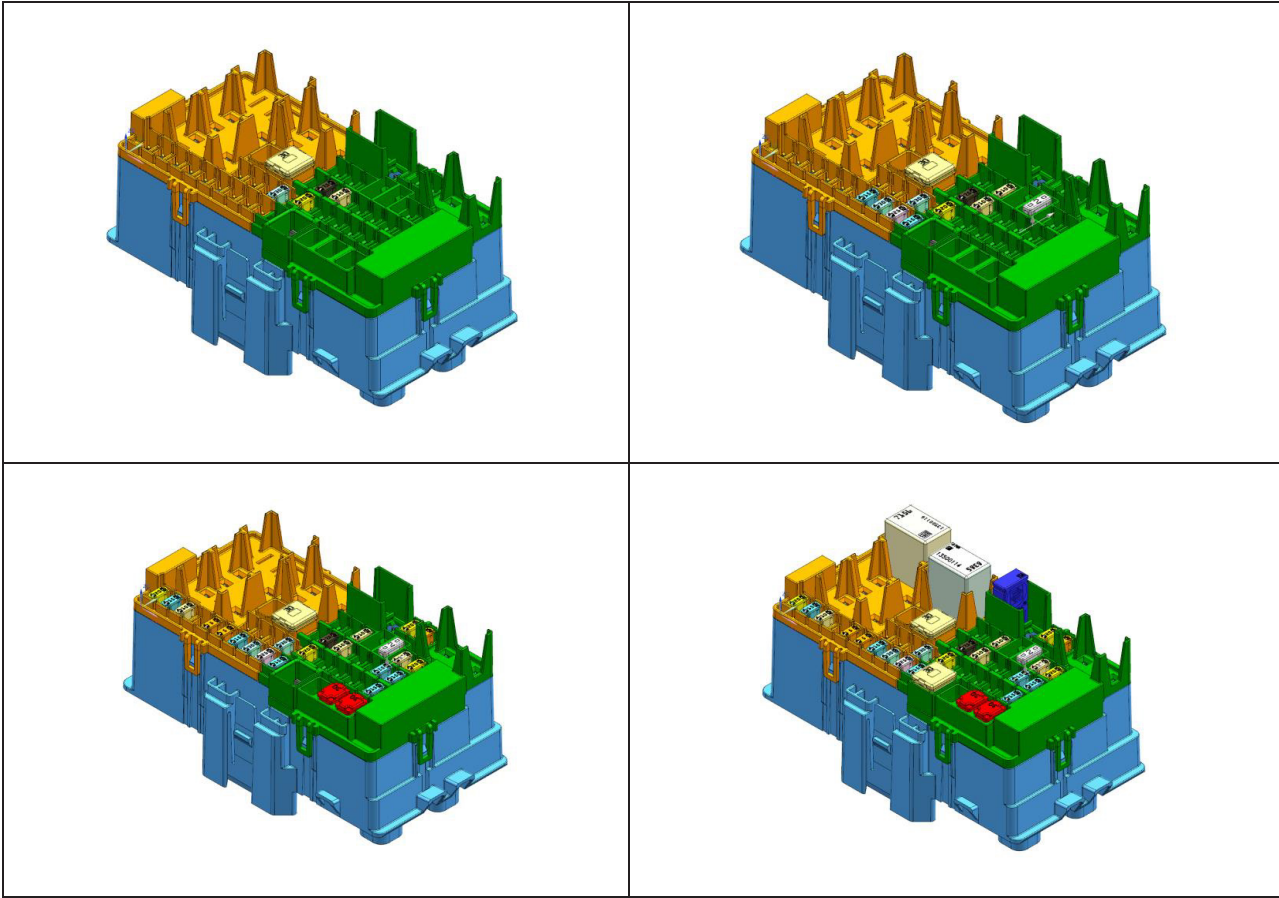

Commencer par insérer les dispositifs ayant le plus bas profil et positionnés au centre du boîtier.

Insérer ensuite les dispositifs ayant le plus haut profil. Tout comme pour les cosses, commencer l'insertion par le centre du boîtier.

DATE	REVISION	AUTH	DR
25MY17	Initial Release - Frank Lertz	N/A	

<p><b>INSTALLATION INSTRUCTIONS</b>  <b>Assembly / Disassembly Instructions</b></p>	
PART NO.	<p><b>23322679</b></p>
SHEET	<p><b>22 OF 84</b></p>

**Placer le couvercle de faisceau de câbles**

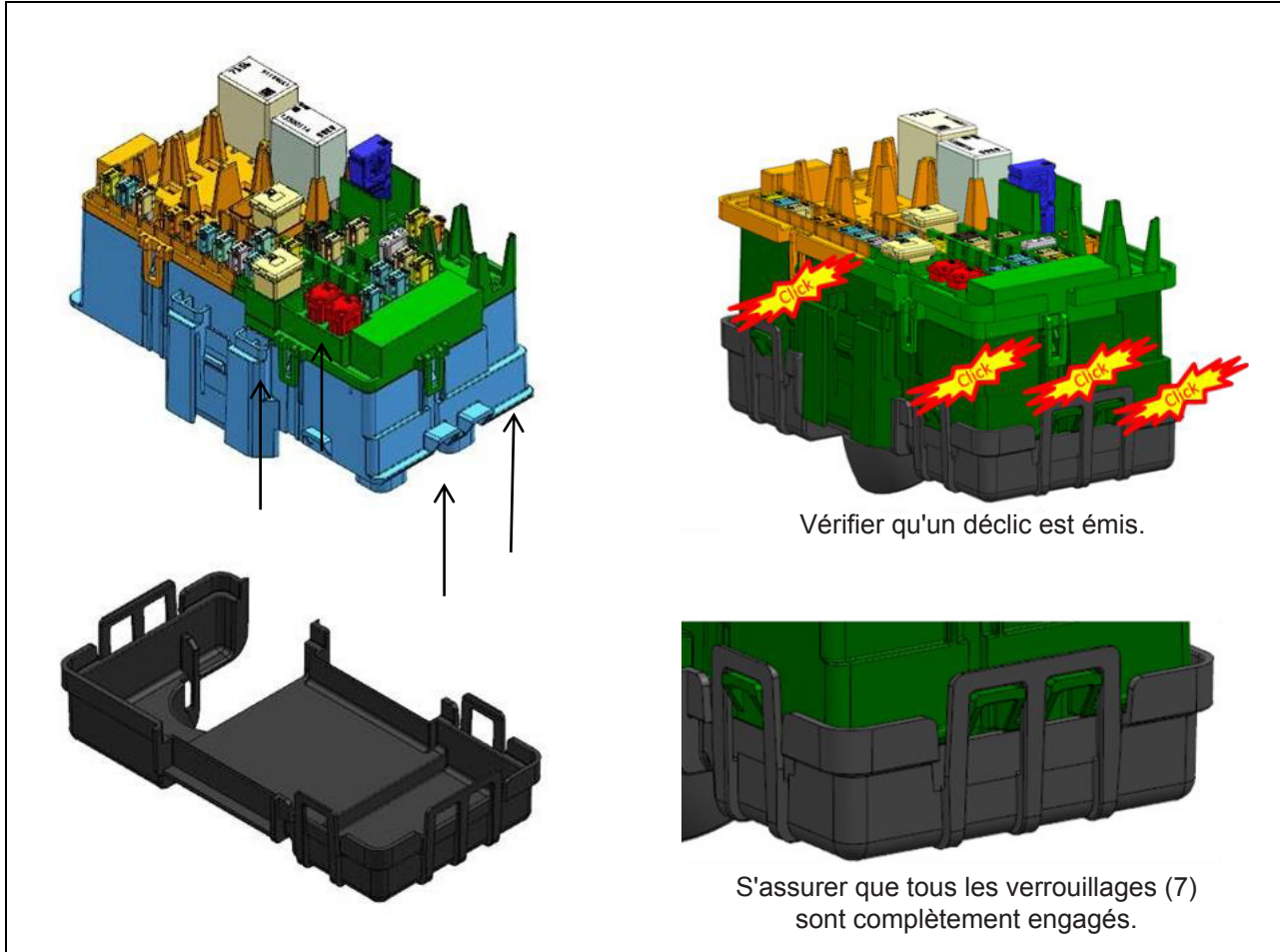

Courber les câbles dans la position requise d'acheminement du faisceau.  
 Attacher le couvercle de faisceau de câbles correspondant au modèle et  
 insérer l'attache-câbles à travers les fentes prévues à cet effet.

DATE	REVISION	AUTH	DR
25MY17	Initial Release - Frank Lertz	N/A	

TITLE	<b>INSTALLATION INSTRUCTIONS</b>		
	<b>Assembly / Disassembly Instructions</b>		
PART NO.	<b>23322679</b>	SHEET	<b>23</b> OF <b>84</b>

**Démontage du centre électrique**

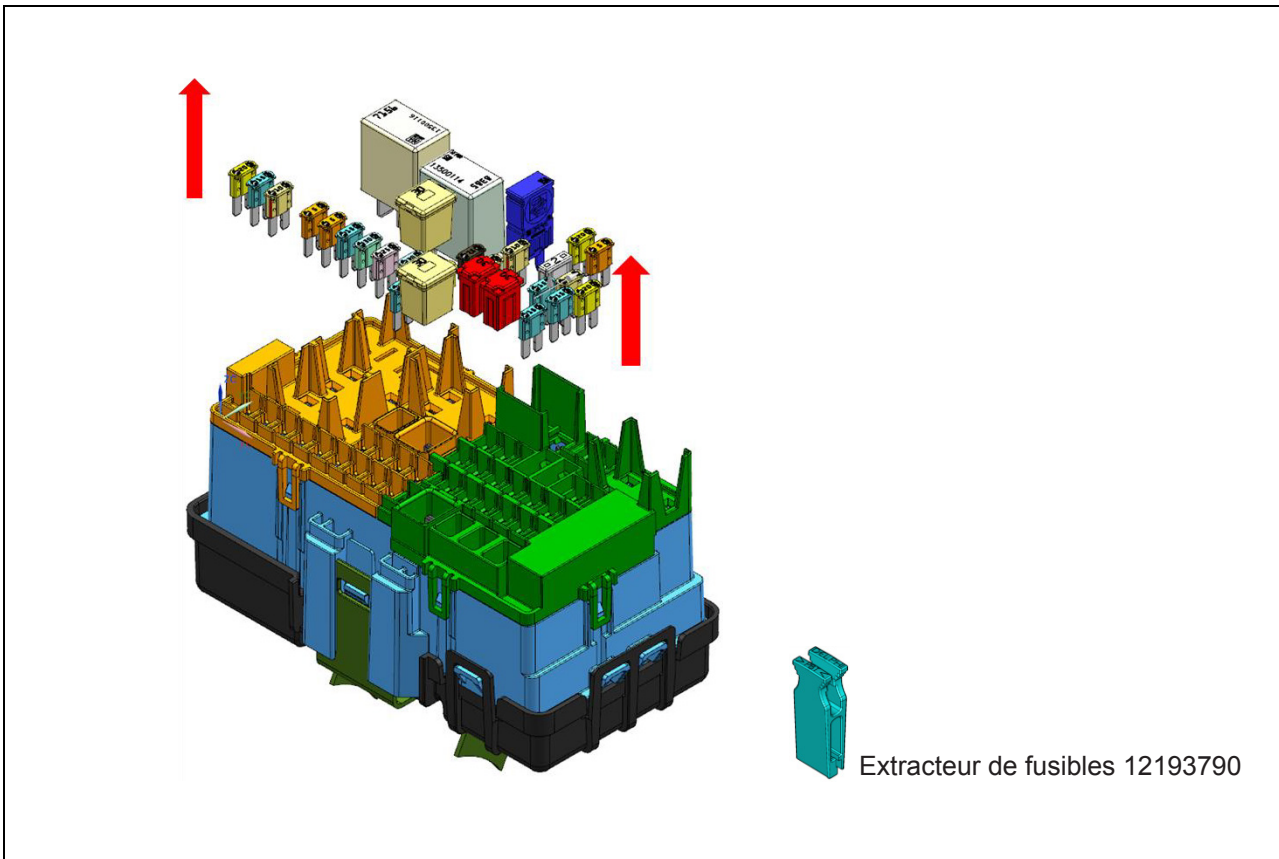

Extraire tous les dispositifs. Utiliser l'extracteur de fusibles Delphi 12193790 (recommandé) pour les extraire.

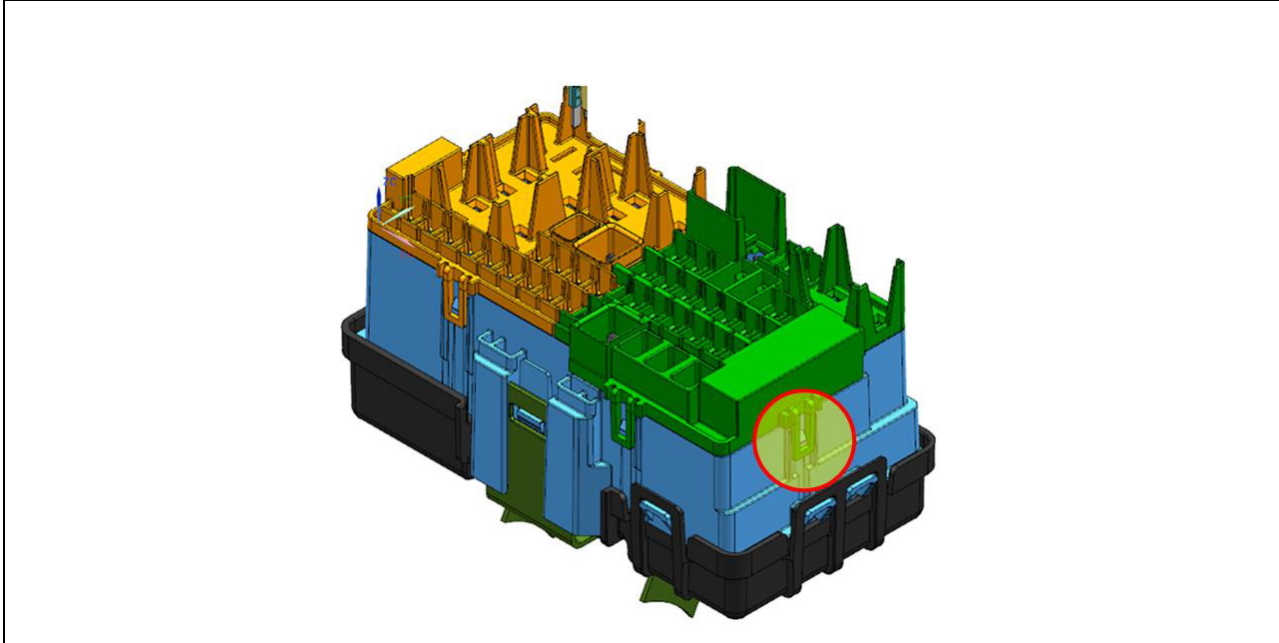

Soulever les verrouillages de PLR.

Il se peut que les verrouillages se brisent lors de l'opération. Veiller à disposer de pièces de rechange.

DATE	REVISION	AUTH	DR
25MY17	Initial Release - Frank Lertz	N/A	

TITLE
<b>INSTALLATION INSTRUCTIONS</b> <b>Assembly / Disassembly Instructions</b>
PART NO. <b>23322679</b> SHEET <b>24 OF 84</b>

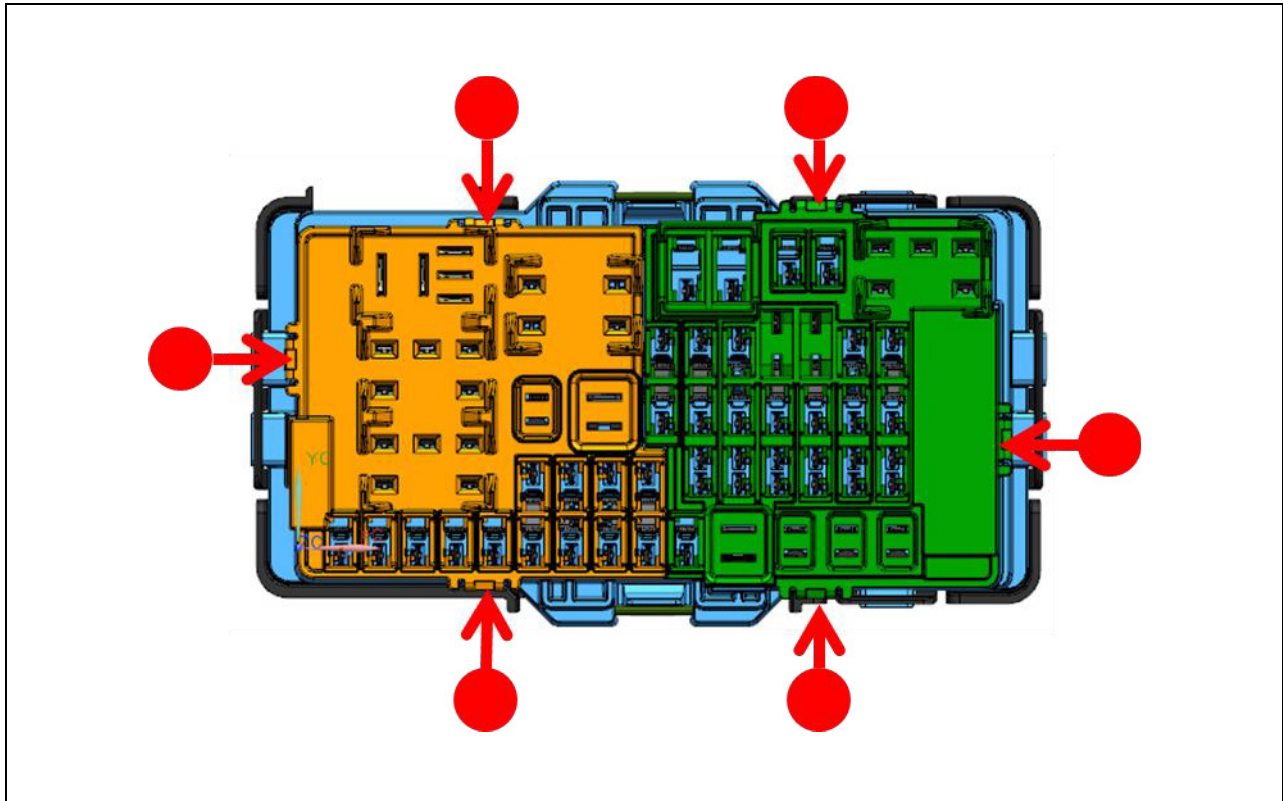

Chaque PLR peut comporter 3 verrouillages ou plus situés dans ou à proximité des positions indiquées par les cercles et flèches rouges.

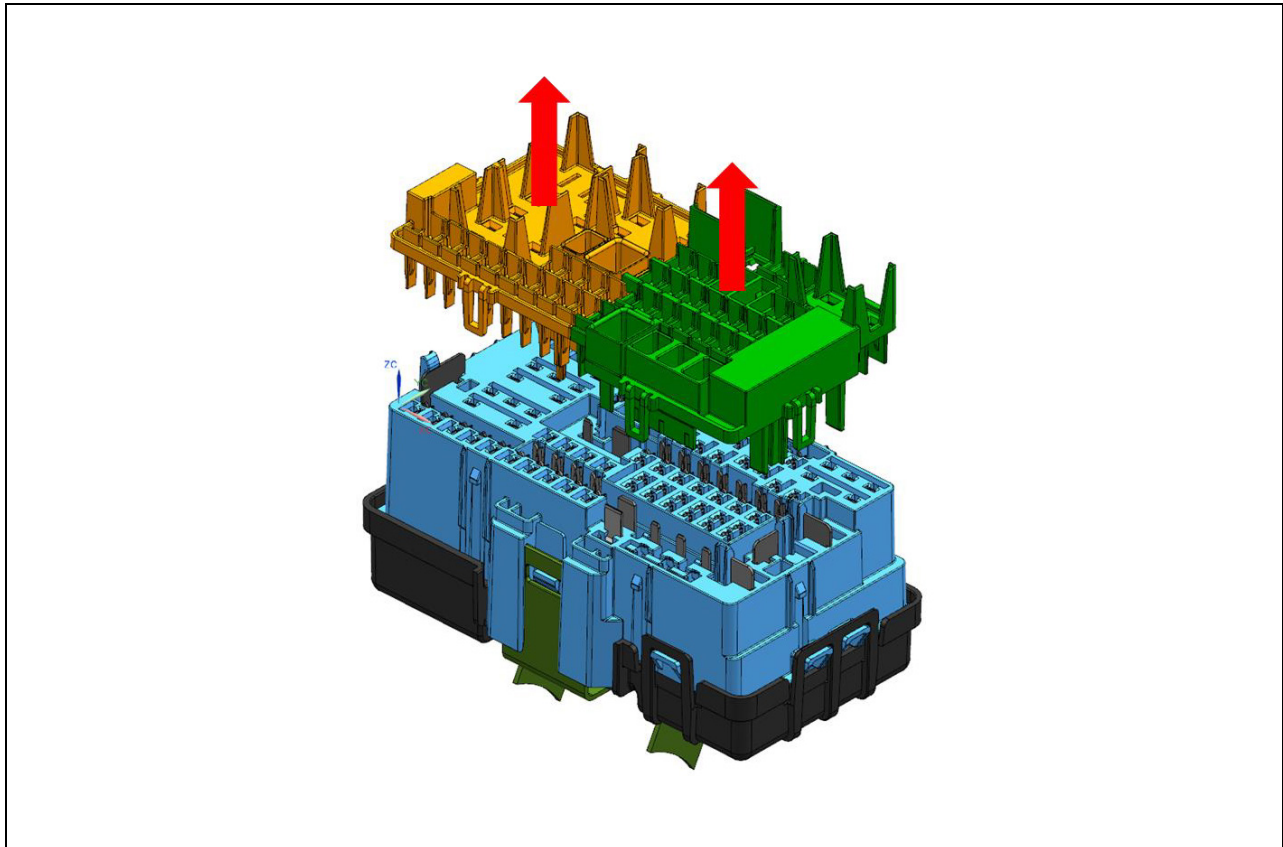

Extraire les PLR

**Assembly / Disassembly Instructions**

**IR 25MY17**

PART NO.

**23322679**

SHEET

**25 OF 84**

ALL INFORMATION WITHIN ABOVE BORDER TO BE PRINTED EXACTLY AS SHOWN ON 8.5 x 11 WHITE 16 POUND NON-BOND RECYCLABLE PAPER. PRINT ON BOTH SIDES, EXCLUDING TEMPLATES. TO BE UNITIZED IN ACCORDANCE WITH GM SPECIFICATIONS.

DATE	REVISION	AUTH	DR
25MY17	Initial Release - Frank Lertz	N/A	

TITLE
<b>INSTALLATION INSTRUCTIONS Assembly / Disassembly Instructions</b>
PART NO. <b>23322679</b> SHEET <b>25 OF 84</b>

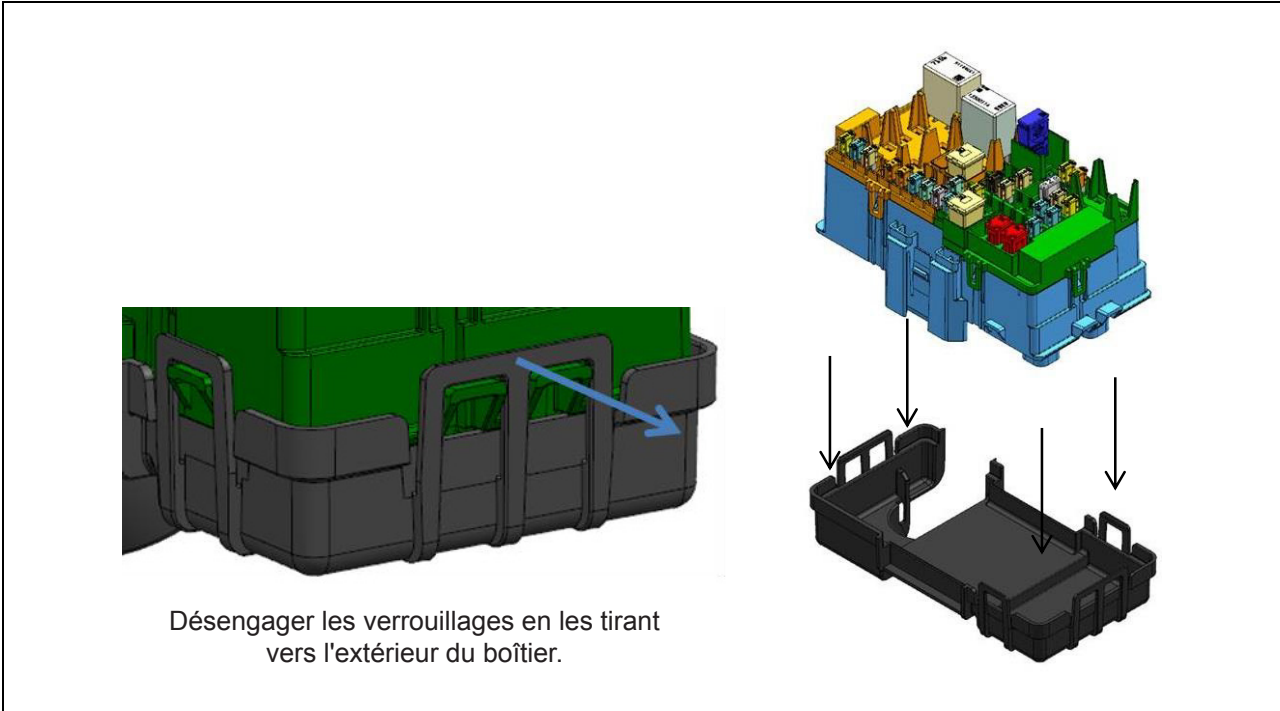

Désengager les verrouillages en les tirant vers l'extérieur du boîtier.

Déposer le couvercle de faisceau de câbles.

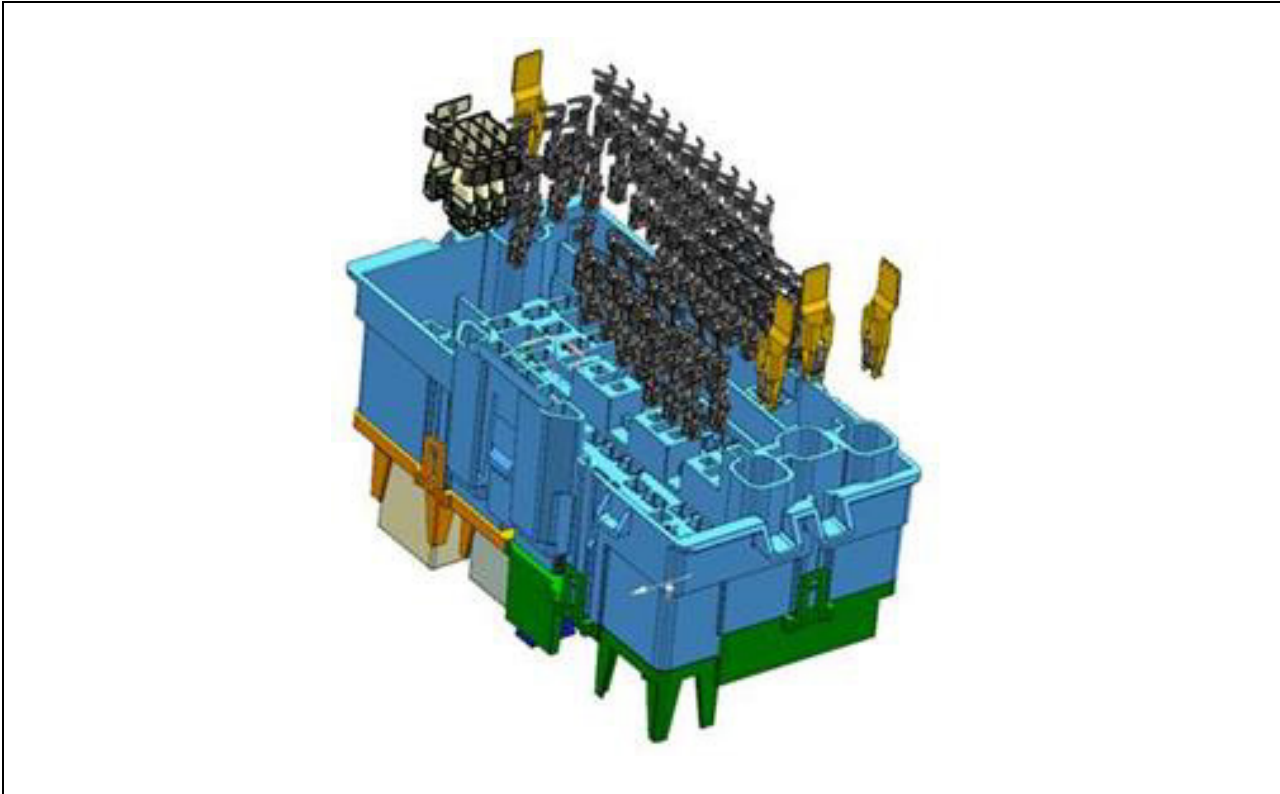

Extraire les cosses une par une en procédant comme suit.

DATE	REVISION	AUTH	DR
25MY17	Initial Release - Frank Lertz	N/A	

TITLE	PART NO.	SHEET
<b>INSTALLATION INSTRUCTIONS Assembly / Disassembly Instructions</b>	<b>23322679</b>	<b>26</b> OF <b>84</b>
	<b>23322679</b>	SHEET <b>26</b> OF <b>84</b>

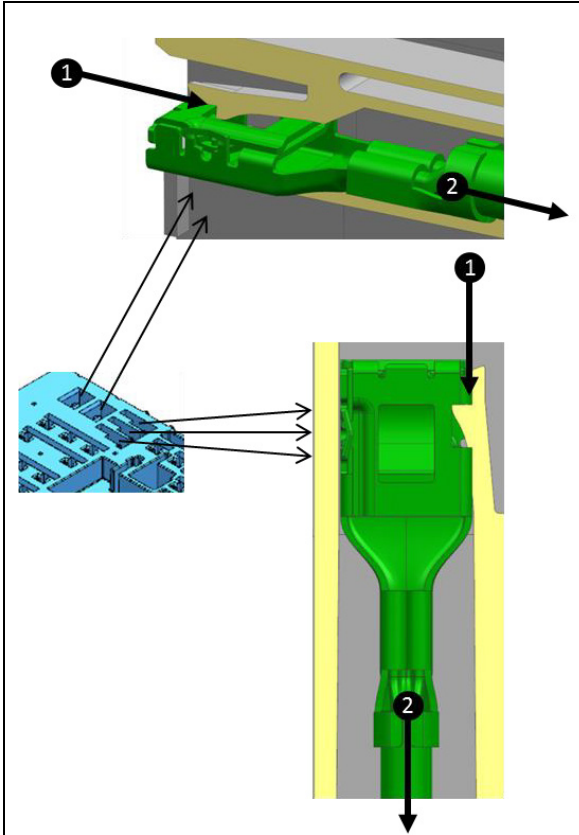

Cosse 630F (relais logique).

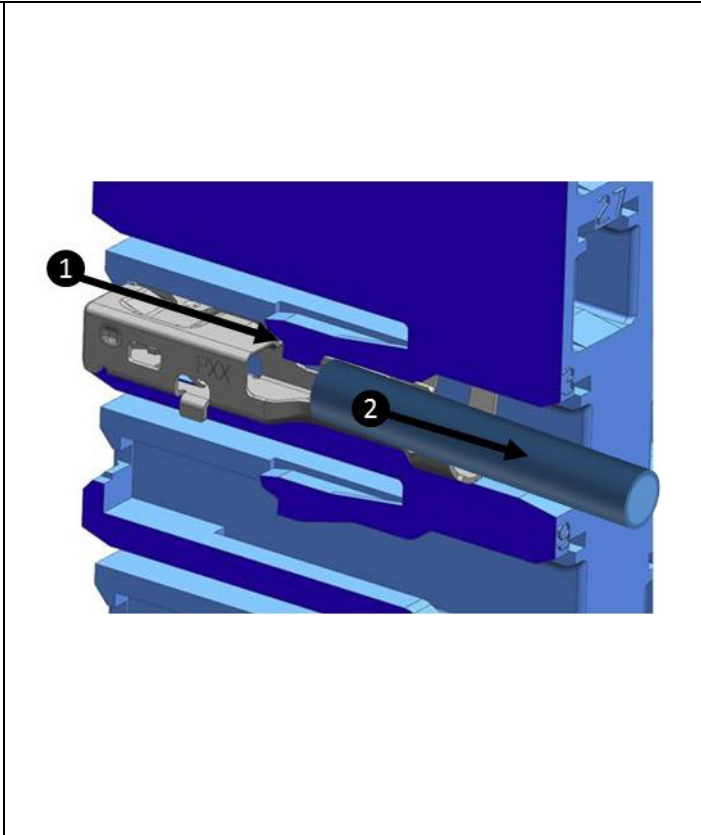

Cosse 280F (fusibles, disjoncteurs et relais).

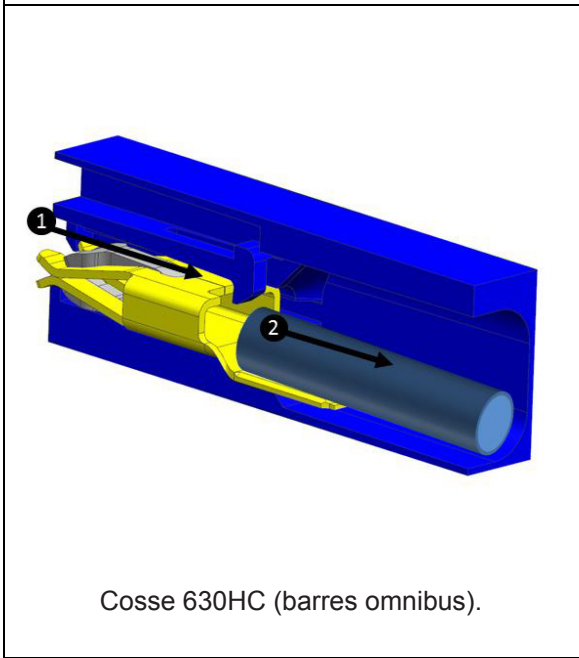

Cosse 630HC (barres omnibus).

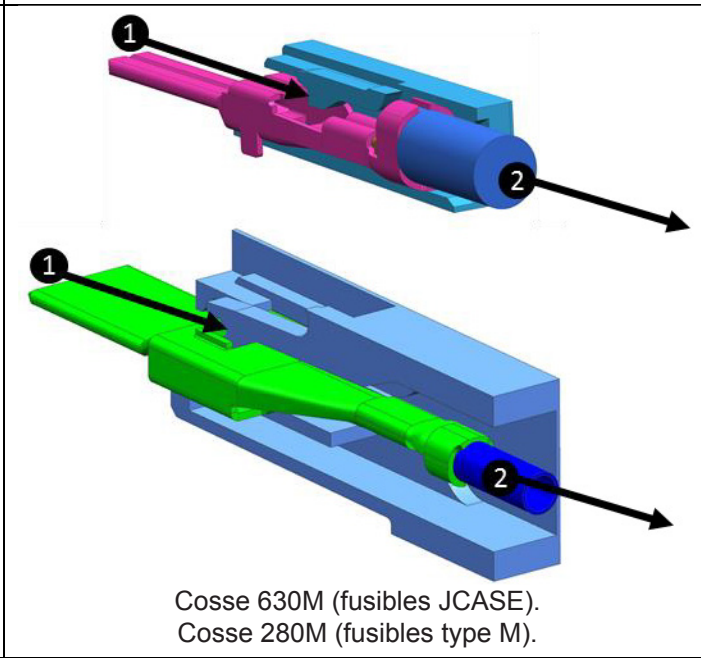

Cosse 630M (fusibles JCASE).  
Cosse 280M (fusibles type M).

**Séquence des opérations**

1. Localiser la languette flexible de verrouillage dans le boîtier en plastique et la soulever.
2. Tirer sur le câble pour extraire sa cosse.

**Assembly / Disassembly Instructions**

IR 25MY17

PART NO.

**23322679**

SHEET

**27 OF 84**

ALL INFORMATION WITHIN ABOVE BORDER TO BE PRINTED EXACTLY AS SHOWN ON 8.5 x 11 WHITE 16 POUND NON-BOND RECYCLABLE PAPER. PRINT ON BOTH SIDES, EXCLUDING TEMPLATES. TO BE UNITIZED IN ACCORDANCE WITH GM SPECIFICATIONS.

DATE	REVISION	AUTH	DR
25MY17	Initial Release - Frank Lertiz	N/A	

TITLE
<b>INSTALLATION INSTRUCTIONS Assembly / Disassembly Instructions</b>
PART NO. <b>23322679</b> SHEET <b>27 OF 84</b>

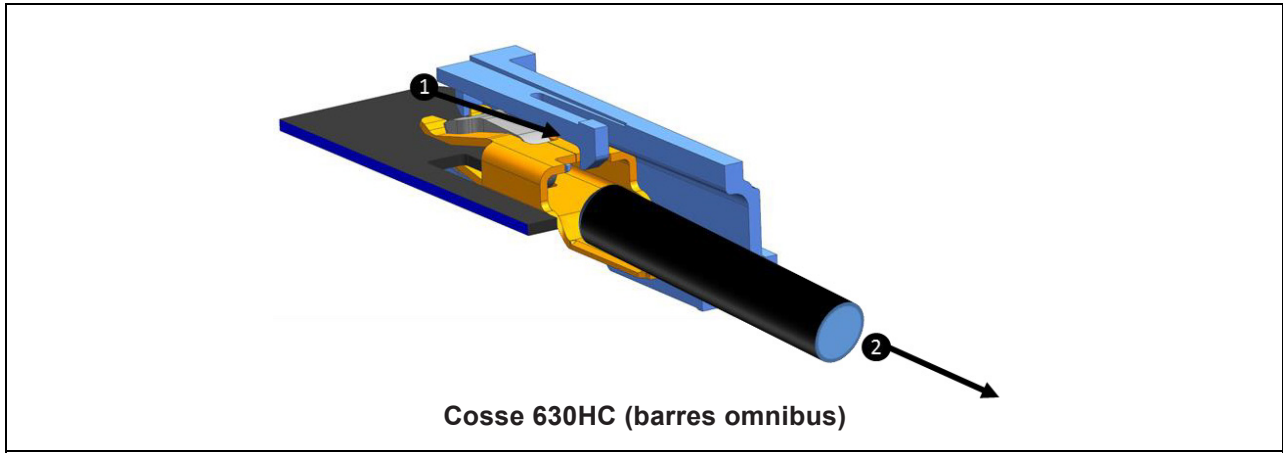

**Cosse 630HC (barres omnibus)**

**Séquence des opérations**

1. Localiser la languette flexible de verrouillage dans le boîtier en plastique et la soulever.
2. Tirer sur le câble pour extraire sa cosse.

**Outils de réparation recommandés**

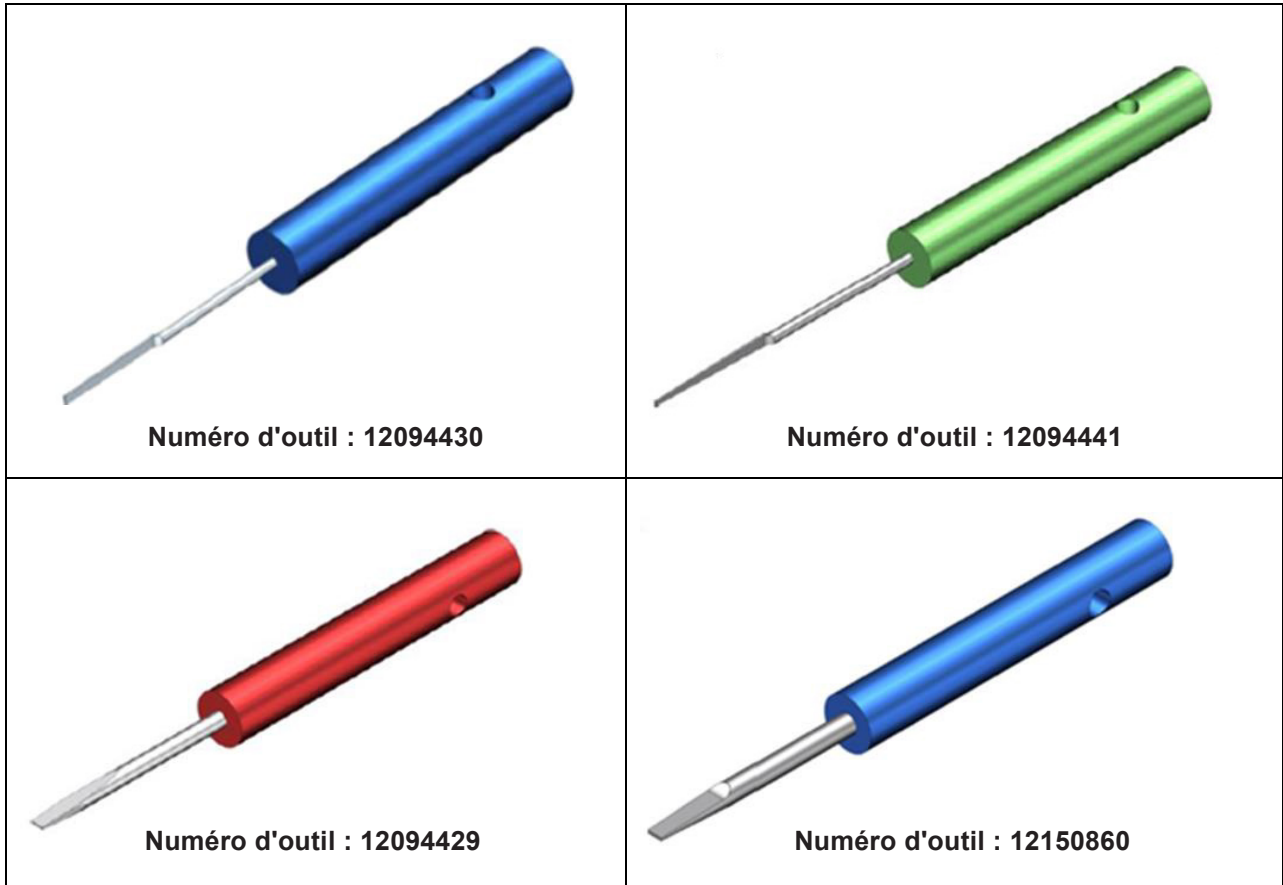

Numéro d'outil : 12094430

Numéro d'outil : 12094441

Numéro d'outil : 12094429

Numéro d'outil : 12150860

DATE	REVISION	AUTH	DR
25MY17	Initial Release - Frank Lertz	N/A	

TITLE	PART NO.	SHEET
<b>INSTALLATION INSTRUCTIONS Assembly / Disassembly Instructions</b>	<b>23322679</b>	<b>28 OF 84</b>

**Instrucciones de ensamble - desensamble**

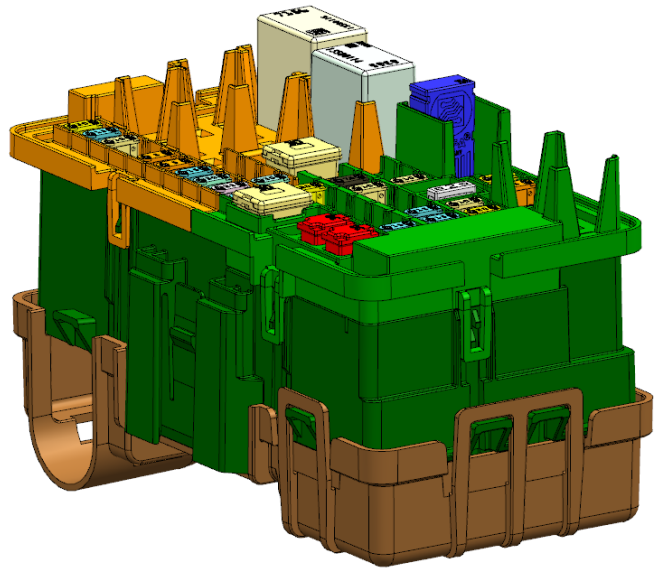
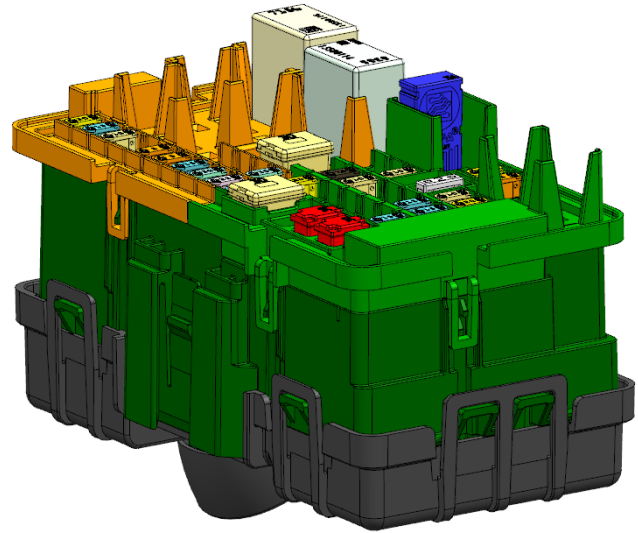

**Assembly / Disassembly Instructions**

**IR 25MY17**

PART NO.

**23322679**

SHEET

**29 OF 84**

ALL INFORMATION WITHIN ABOVE BORDER TO BE PRINTED EXACTLY AS SHOWN ON 8.5 x 11 WHITE 16 POUND NON-BOND RECYCLABLE PAPER. PRINT ON BOTH SIDES, EXCLUDING TEMPLATES. TO BE UNITIZED IN ACCORDANCE WITH GM SPECIFICATIONS.

DATE	REVISION	AUTH	DR
25MY17	Initial Release - Frank Lertz	N/A	

TITLE	<b>INSTALLATION INSTRUCTIONS Assembly / Disassembly Instructions</b>		
PART NO.	<b>23322679</b>	SHEET	<b>29 OF 84</b>

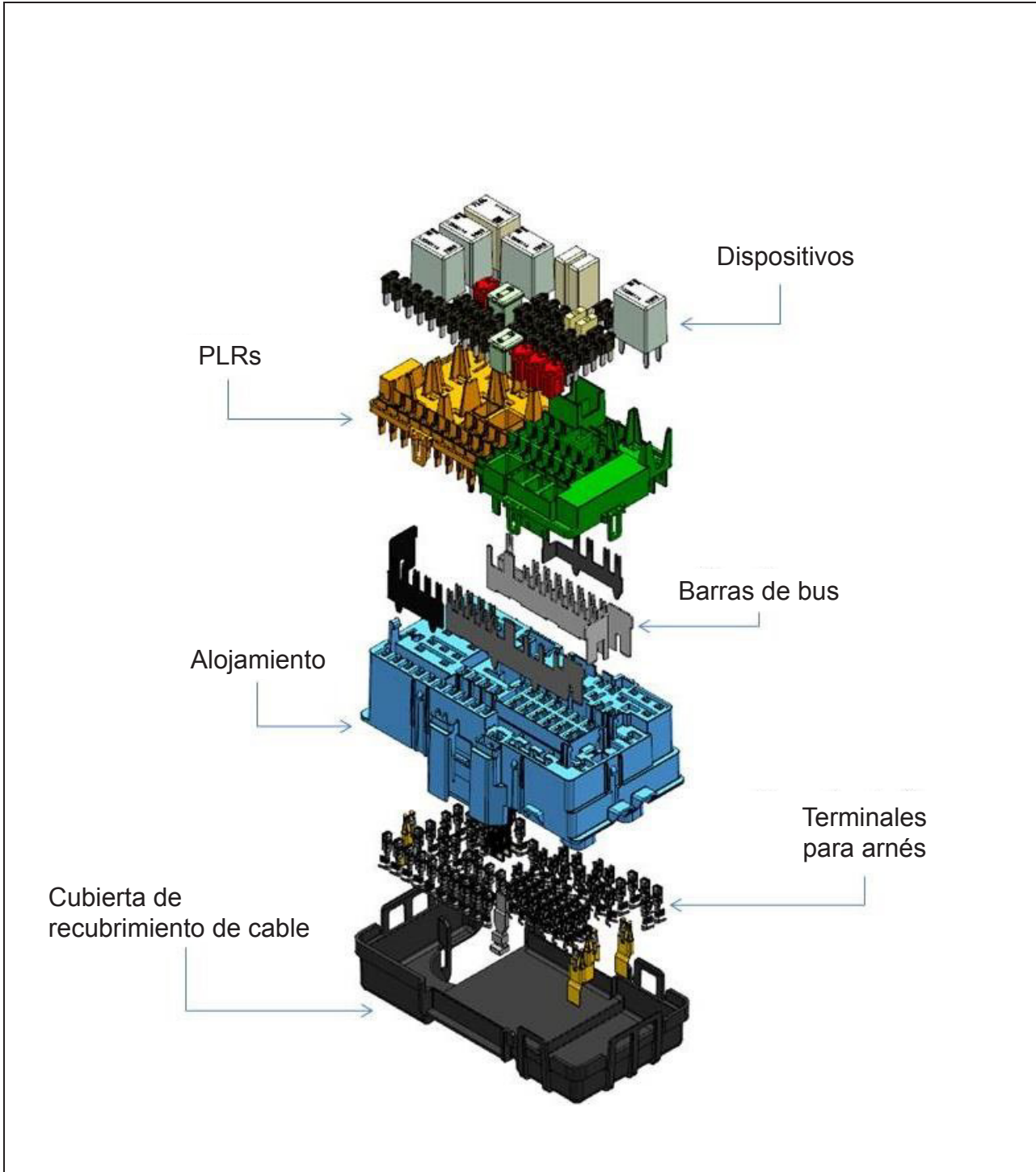

**Plano de despiece**



DATE	REVISION	AUTH	DR
25MY17	Initial Release - Frank Lertz	N/A	

TITLE	<b>INSTALLATION INSTRUCTIONS Assembly / Disassembly Instructions</b>		
PART NO.	<b>23322679</b>	SHEET	<b>30 OF 84</b>

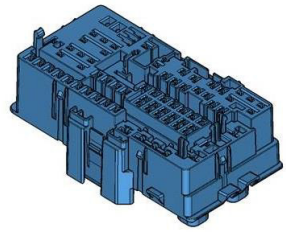
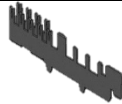
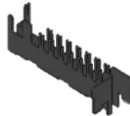
**Lista de materiales**

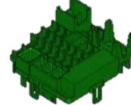
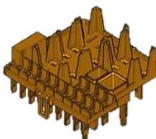
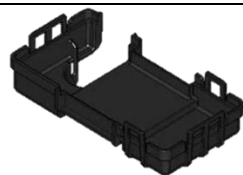
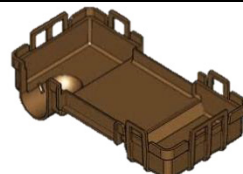
Descripción		Número de parte PE	Número de parte de 8 dígitos	
Alojamiento - Barra de bus Subensamble 33272518	Alojamiento	PE242429	33152669	
	Barra de bus	PE242426	33152670	
	Barra de bus	PE242427	33152672	
	Barra de bus	PE255013	33152673	
	Barra de bus	PE260273	33152674	
PLR		PE286899	33152676	
PLR		PE286900	33152677	
Cubierta de recubrimiento de cable		PE242430	33152678	
Cubierta de recubrimiento de cable		PE264537	33152679	

**Assembly / Disassembly Instructions**

**IR 25MY17**

PART NO. **23322679**

SHEET **31** OF **84**

ALL INFORMATION WITHIN ABOVE BORDER TO BE PRINTED EXACTLY AS SHOWN ON 8.5 x 11 WHITE 16 POUND NON-BOND RECYCLABLE PAPER. PRINT ON BOTH SIDES, EXCLUDING TEMPLATES. TO BE UNITIZED IN ACCORDANCE WITH GM SPECIFICATIONS.

DATE	REVISION	AUTH	DR
25MY17	Initial Release - Frank Lertz	N/A	

<b>INSTALLATION INSTRUCTIONS</b>	
<b>Assembly / Disassembly Instructions</b>	
PART NO. <b>23322679</b>	SHEET <b>31</b> OF <b>84</b>

**Numeración de cavidad**

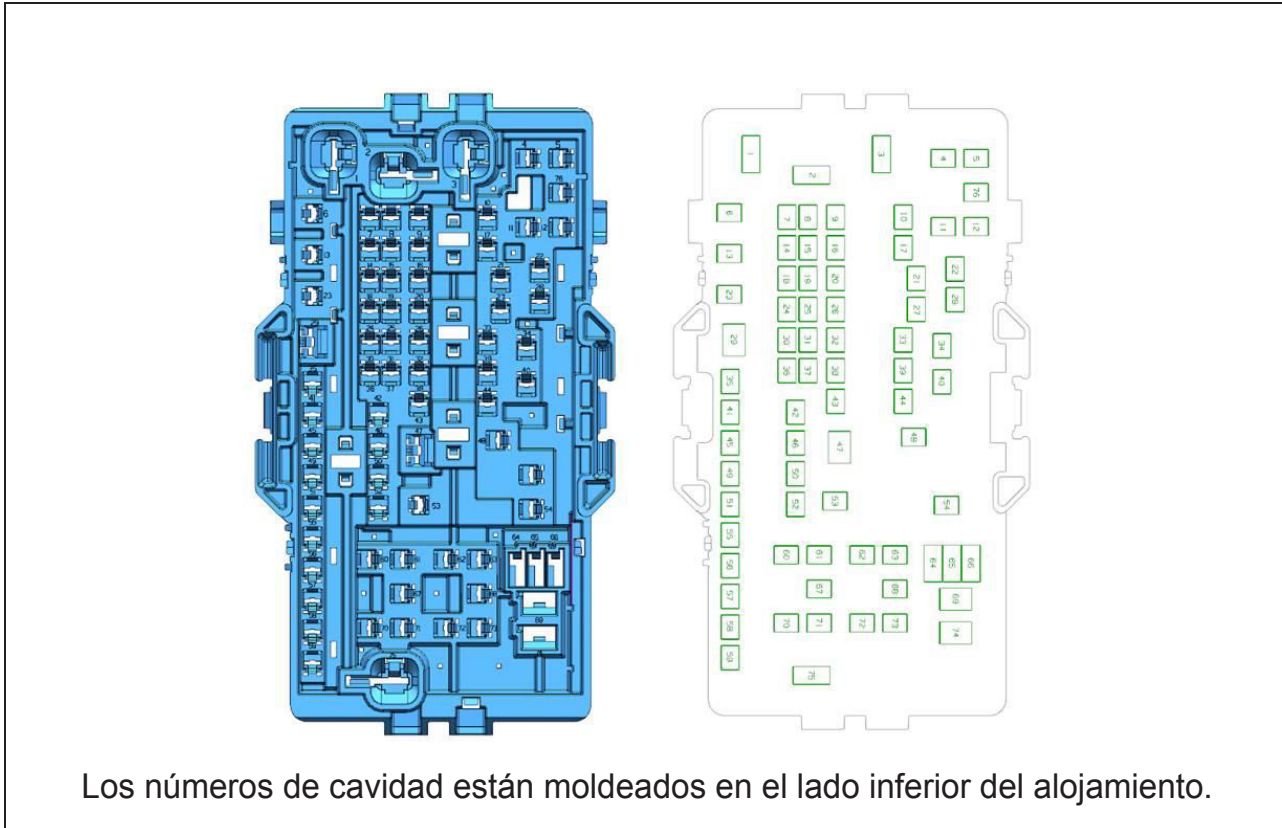

Los números de cavidad están moldeados en el lado inferior del alojamiento.

CAVITY INFORMATION			
CAVITY NAME	TERMINAL	DESCRIPTION	TYPICAL USE
1, 2, 3, 75	13979887	630 ASM F TERMINAL AG	BUSS BARS
4, 5, 7, 8, 9, 10, 11, 12, 14, 15, 16, 17, 18, 19, 20, 21, 22, 24, 25, 26, 27, 28, 30, 31, 32, 33, 34, 35, 36, 37, 38, 39, 40, 41, 42, 43, 44, 45, 46, 48, 49, 50, 51, 52, 54, 55, 56, 57, 58, 59, 60, 61, 62, 63, 67, 68, 70, 71, 72, 73, 76, 77	13849936	280 OCS F TERMINAL	RELAYS AND FUSES
6, 13, 23, 53	10725700	280 M TERMINAL	M-TYPE FUSE
29, 74	10725704	630 M TERMINAL	J-CASE FUSE
64, 65, 66, 69, 74	15344770	630 RELAY TERMINAL	LOGISTICS RELAY

Tabla de referencia para tipo de cavidad por número de cavidad

DATE	REVISION	AUTH	DR
25MY17	Initial Release - Frank Lertiz	N/A	

TITLE
<b>INSTALLATION INSTRUCTIONS Assembly / Disassembly Instructions</b>
PART NO. <b>23322679</b> SHEET <b>32 OF 84</b>

**Inserción de terminal**

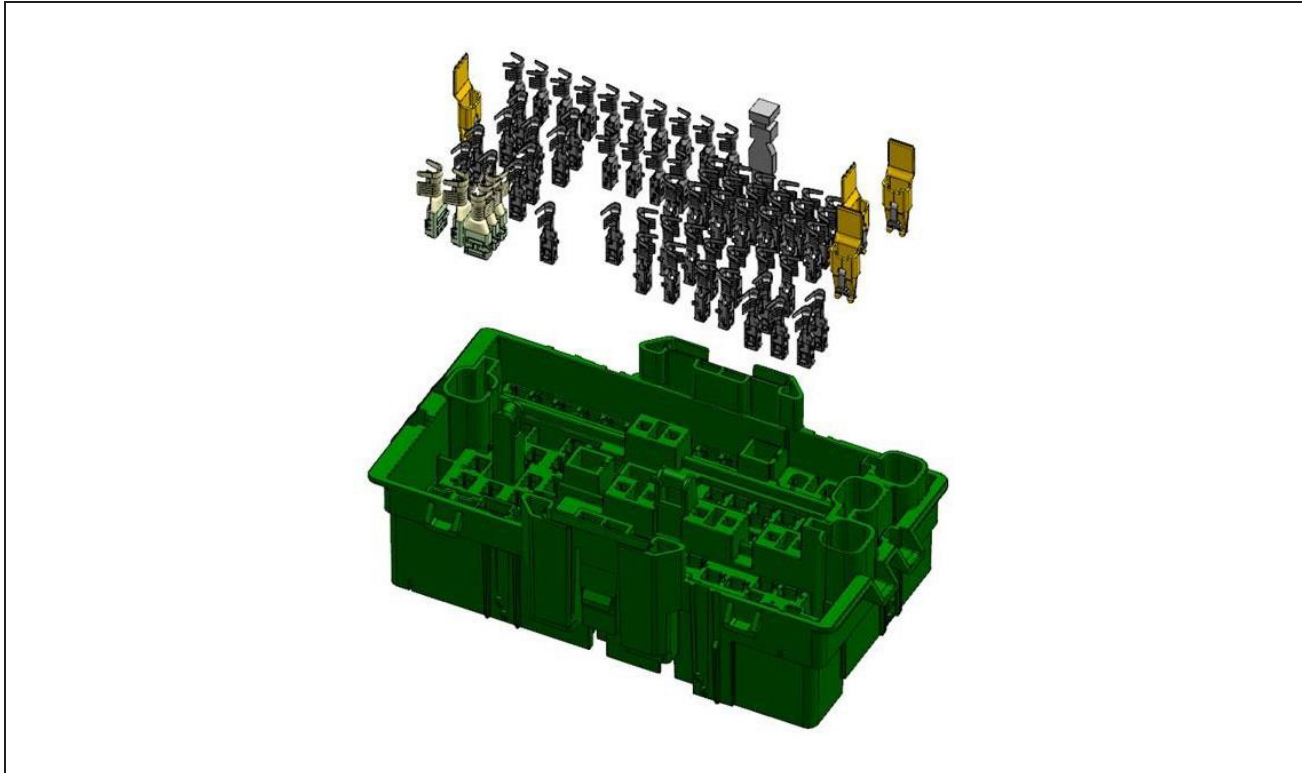

Inserte las terminales por el lado inferior en su cavidad correspondiente.  
(Vea la tabla en la página anterior)

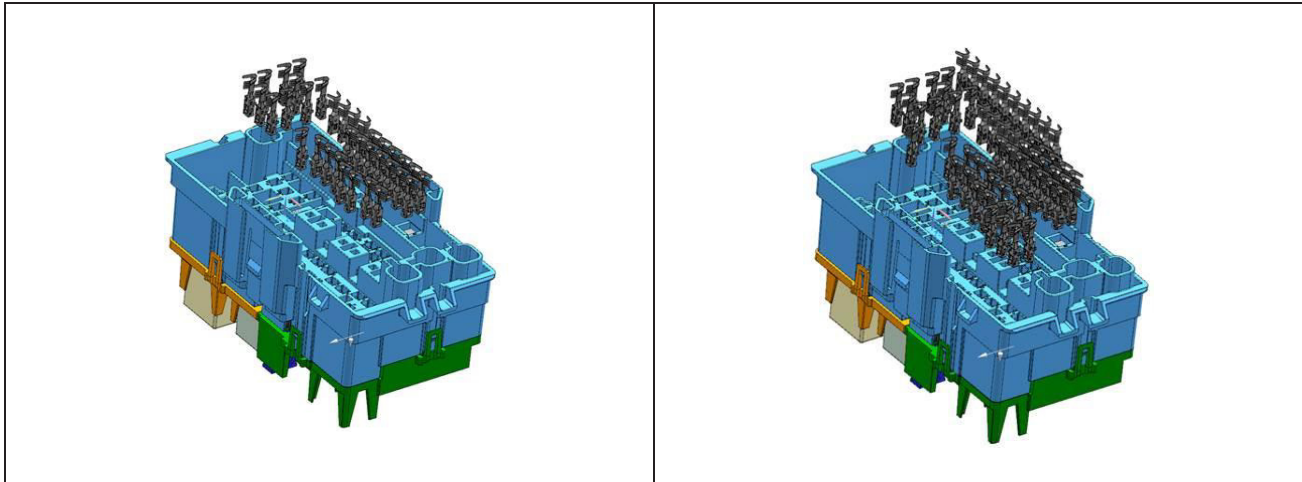

DATE	REVISION	AUTH	DR
25MY17	Initial Release - Frank Leritz	N/A	

TITLE	<b>INSTALLATION INSTRUCTIONS Assembly / Disassembly Instructions</b>		
PART NO.	<b>23322679</b>	SHEET	<b>33 OF 84</b>

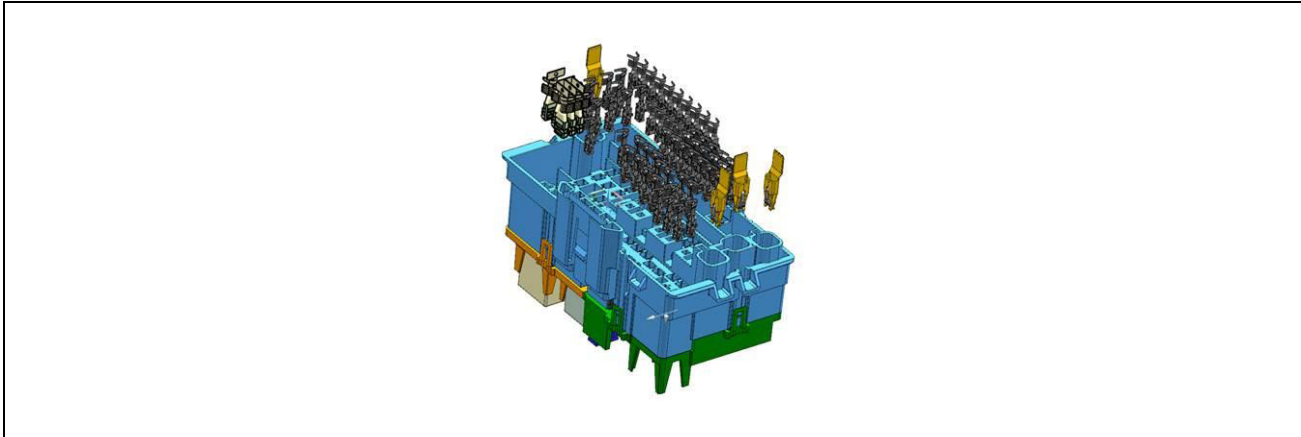

Comience la inserción de terminales en el centro del alojamiento continuando a los bordes



Inserte las terminales en la carrocería principal

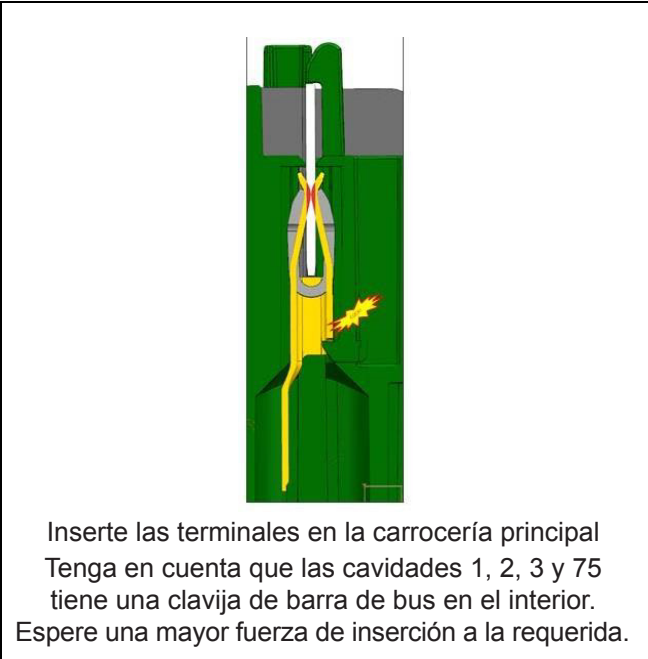

Inserte las terminales en la carrocería principal  
 Tenga en cuenta que las cavidades 1, 2, 3 y 75  
 tiene una clavija de barra de bus en el interior.  
 Espere una mayor fuerza de inserción a la requerida.

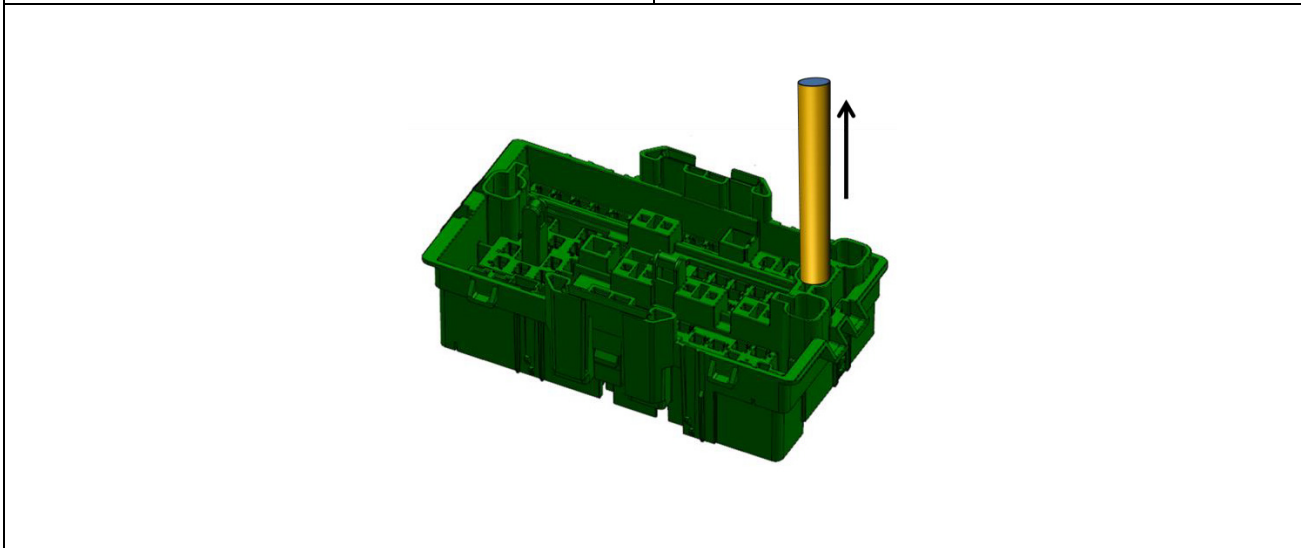

Después de cada inserción, jale suavemente sobre el cable para verificar el sistema de bloqueo

**Assembly / Disassembly Instructions**

IR 25MY17 PART NO. **23322679** SHEET **34** OF **84**

ALL INFORMATION WITHIN  
 ABOVE BORDER TO BE PRINTED  
 EXACTLY AS SHOWN ON 8.5 x 11  
 WHITE 16 POUND NON-BOND  
 RECYCLABLE PAPER.  
 PRINT ON BOTH SIDES, EXCLUD-  
 ING TEMPLATES.  
 TO BE UNITIZED IN ACCORDANCE  
 WITH GM SPECIFICATIONS.

DATE	REVISION	AUTH	DR
25MY17	Initial Release - Frank Lertz	N/A	

TITLE	PART NO.	SHEET	OF
<b>INSTALLATION INSTRUCTIONS</b> <b>Assembly / Disassembly Instructions</b>	<b>23322679</b>	<b>34</b>	<b>84</b>
	<b>23322679</b>	SHEET	<b>34</b> OF <b>84</b>

**Coloque los PLR**

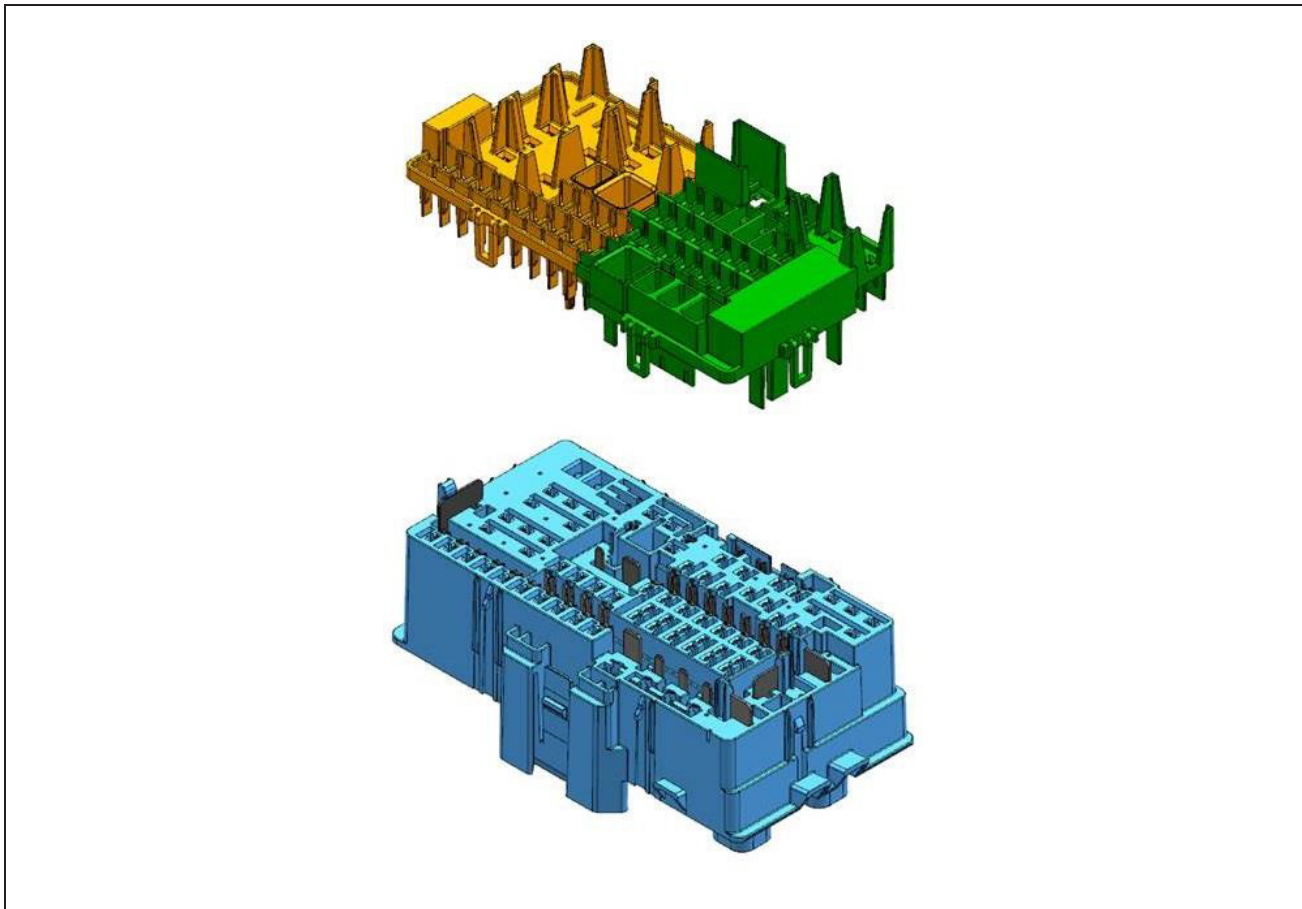

Los PLR (dos) se pueden ensamblar uno después del otro. No hay un orden para el ensamble.

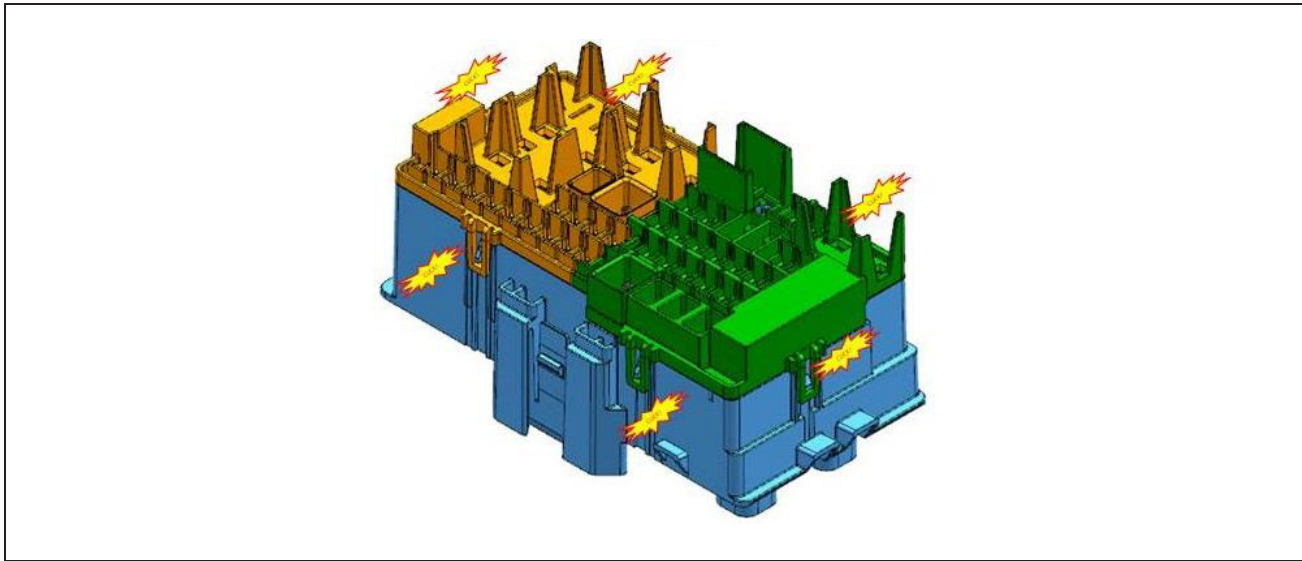

Presione los PLR completamente en el alojamiento hasta que se escuche un clic, se puede requerir asistencia mecánica.

DATE	REVISION	AUTH	DR
25MY17	Initial Release - Frank Lertz	N/A	

TITLE	<b>INSTALLATION INSTRUCTIONS Assembly / Disassembly Instructions</b>		
PART NO.	<b>23322679</b>	SHEET	<b>35</b> OF <b>84</b>

**Inserte los dispositivos**

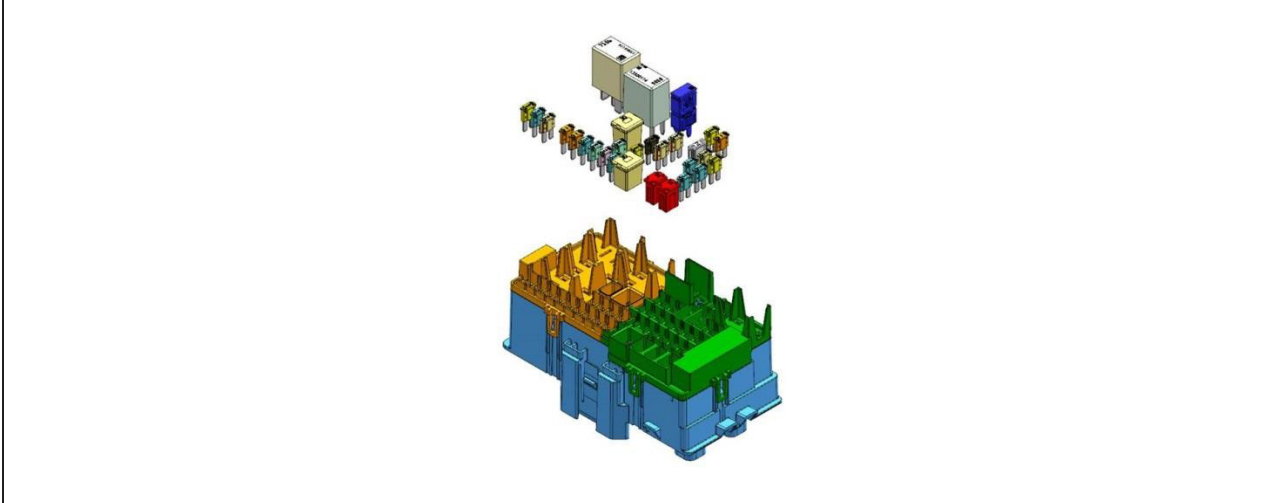

Inserte los fusibles y relevadores conforme se requiera por modelo.

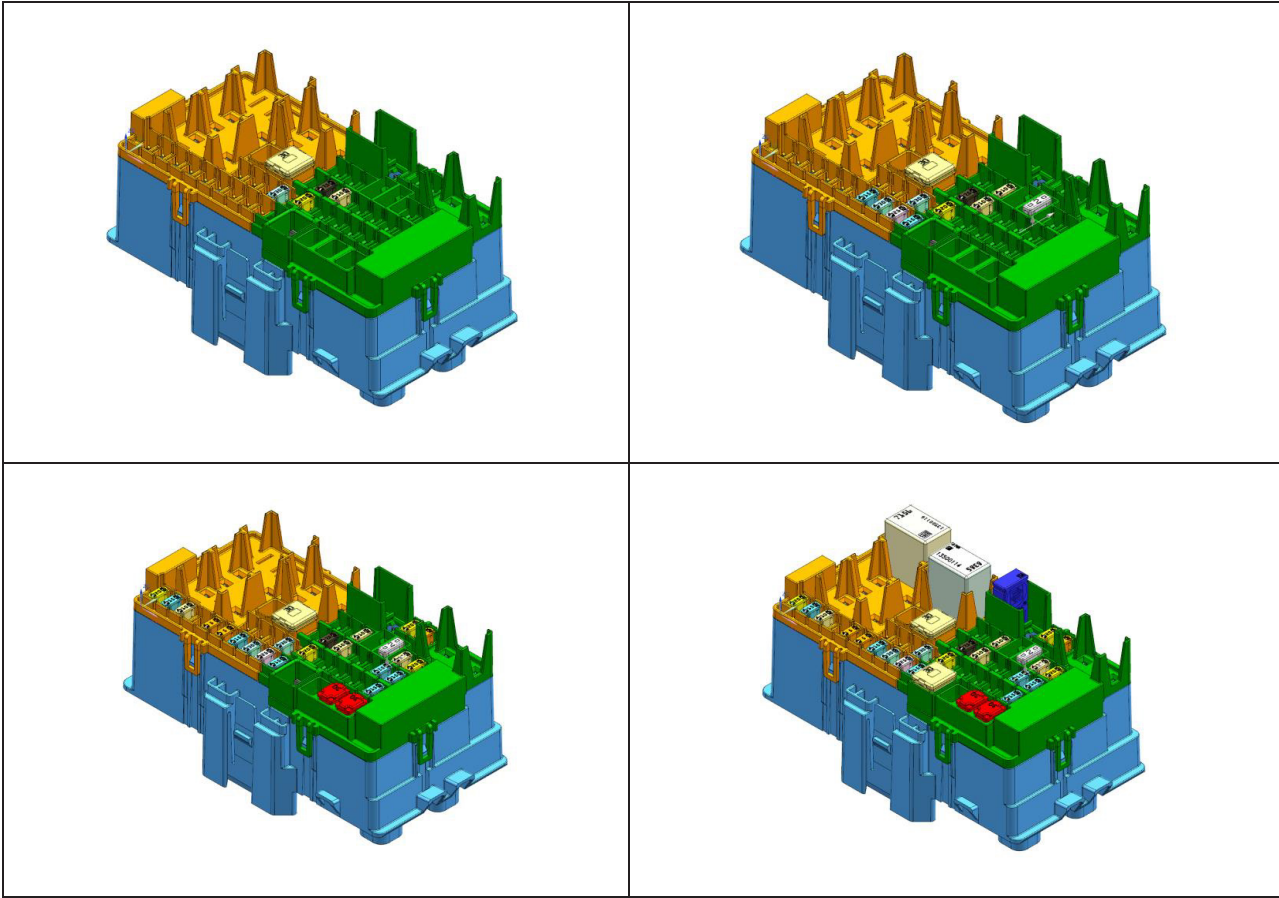

Primero inserte los dispositivos con el perfil más bajo y ubicado en el centro del alojamiento.

Continúe con los dispositivos de mayor perfil. Como con las terminales, comience la inserción en el centro del alojamiento.

DATE	REVISION	AUTH	DR
25MY17	Initial Release - Frank Lertz	N/A	

TITLE	PART NO.	SHEET
<b>INSTALLATION INSTRUCTIONS Assembly / Disassembly Instructions</b>	<b>23322679</b>	<b>36 OF 84</b>

**Coloque la cubierta de recubrimiento de cable**

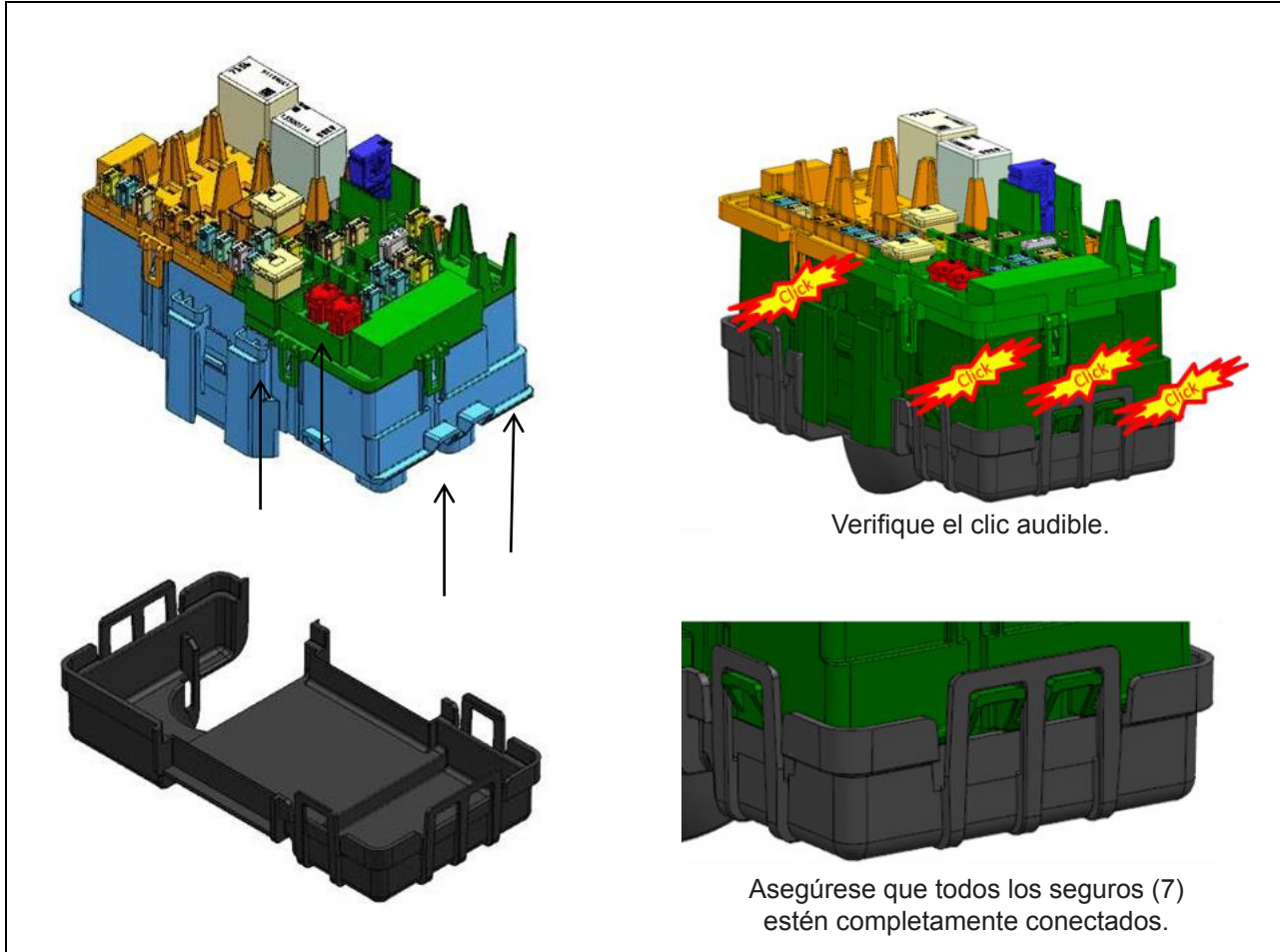

Verifique el clic audible.

Asegúrese que todos los seguros (7) estén completamente conectados.

Doble los cables a la posición de enrutamiento requerida del arnés.  
 Conecte la cubierta de recubrimiento de cable adecuada conforme al modelo e inserte el amarre de cable a través de las ranuras provistas.

DATE	REVISION	AUTH	DR
25MY17	Initial Release - Frank Lertz	N/A	

TITLE	<b>INSTALLATION INSTRUCTIONS</b>		
	<b>Assembly / Disassembly Instructions</b>		
PART NO.	<b>23322679</b>	SHEET	<b>37 OF 84</b>

**Desensamble del centro eléctrico**

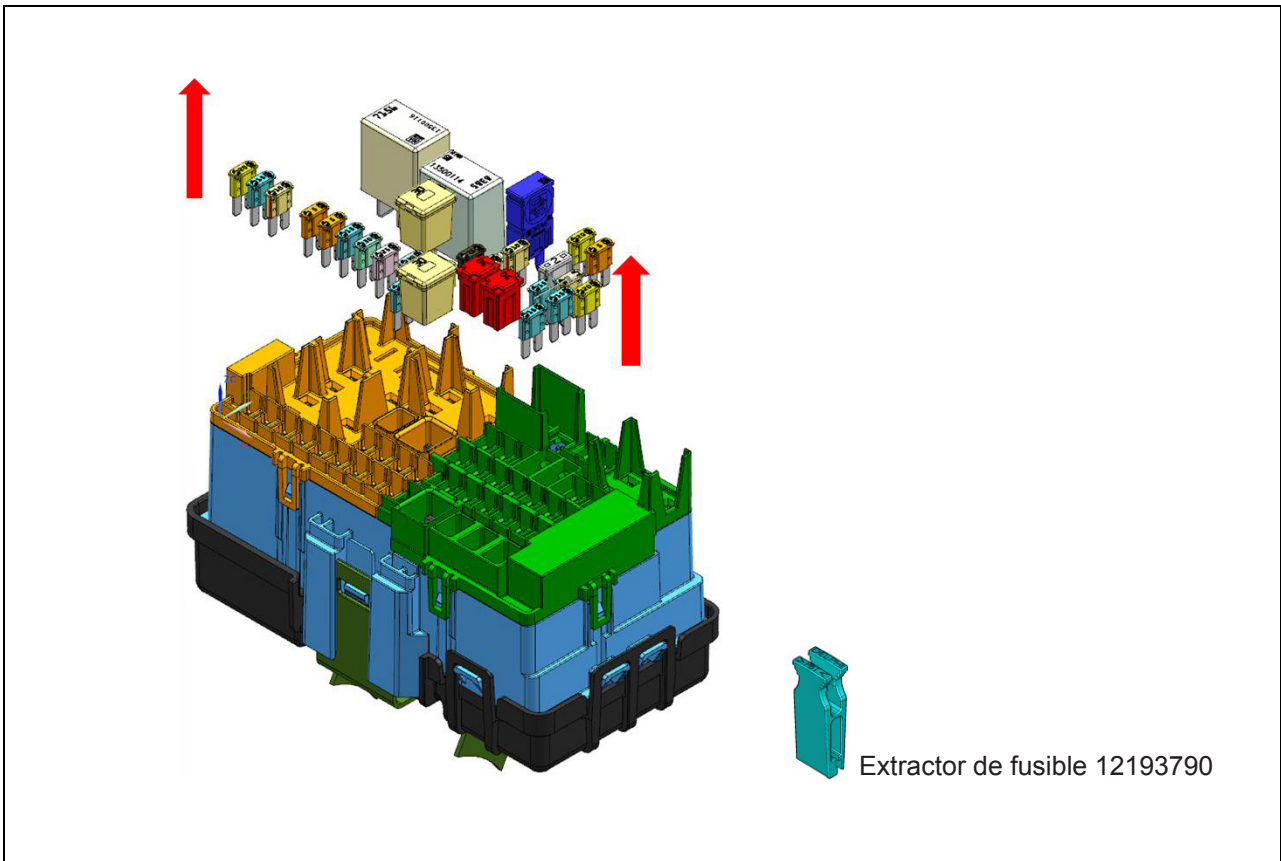

Retire todos los dispositivos. Use el extractor de fusibles Delphi 12193790 (recomendado) para retirar.

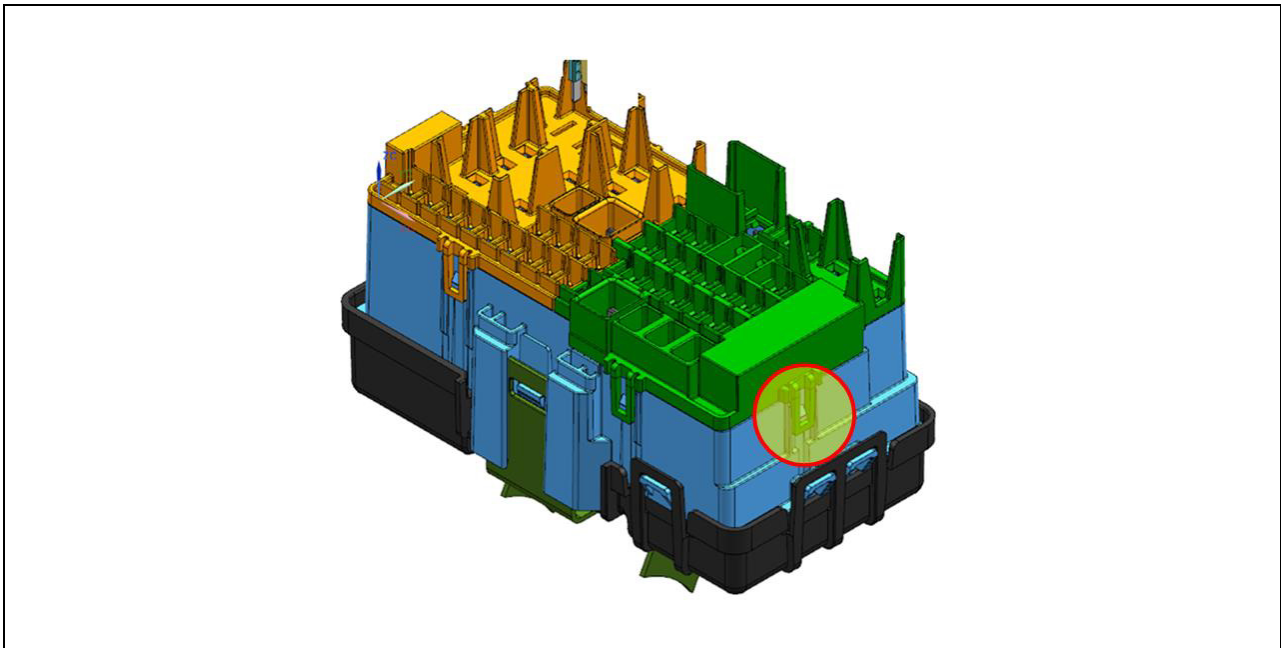

Levante los seguros de PLR.  
Los seguros se podrían romper durante la operación. Tenga partes de repuesto disponibles.

DATE	REVISION	AUTH	DR
25MY17	Initial Release - Frank Lertz	N/A	

TITLE
<b>INSTALLATION INSTRUCTIONS</b>
<b>Assembly / Disassembly Instructions</b>
PART NO. <b>23322679</b>
SHEET <b>38 OF 84</b>

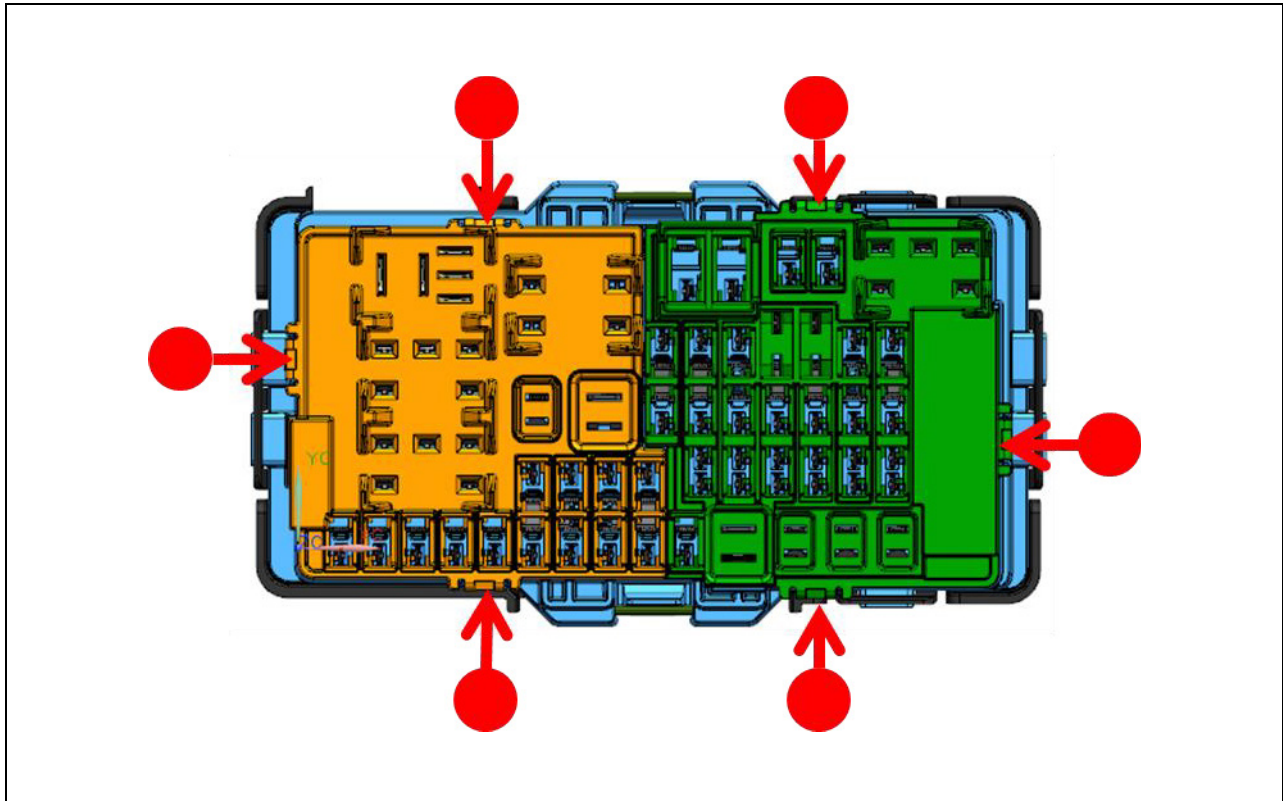

Cada PLR tiene 3 seguros o más ubicados en o cerca de las posiciones donde se muestran los círculos y flechas rojos.

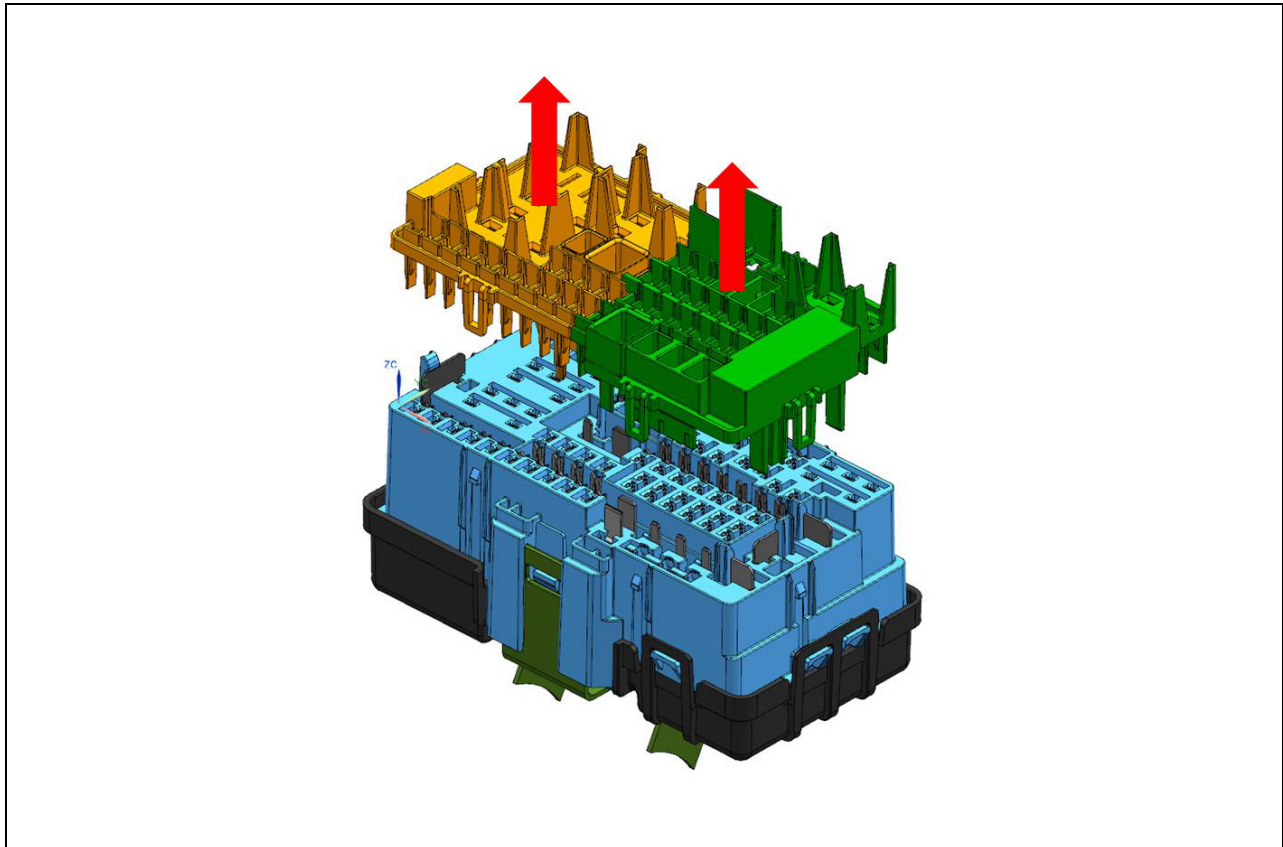

Retire los PLR

**Assembly / Disassembly Instructions**

**IR 25MY17**

PART NO.

**23322679**

SHEET

**39 OF 84**

ALL INFORMATION WITHIN ABOVE BORDER TO BE PRINTED EXACTLY AS SHOWN ON 8.5 x 11 WHITE 16 POUND NON-BOND RECYCLABLE PAPER. PRINT ON BOTH SIDES, EXCLUDING TEMPLATES. TO BE UNITIZED IN ACCORDANCE WITH GM SPECIFICATIONS.

DATE	REVISION	AUTH	DR
25MY17	Initial Release - Frank Lertz	N/A	

TITLE
<b>INSTALLATION INSTRUCTIONS Assembly / Disassembly Instructions</b>
PART NO. <b>23322679</b>
SHEET <b>39 OF 84</b>

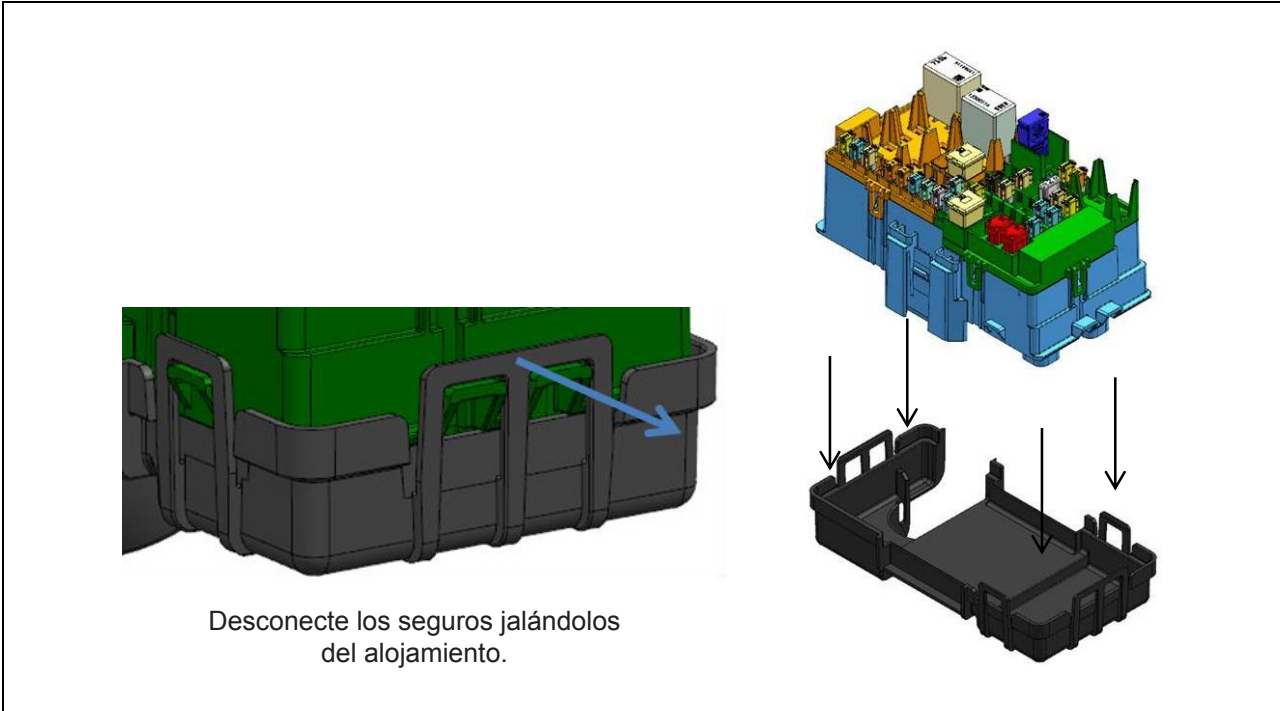

Desconecte los seguros jalándolos del alojamiento.

Retire la cubierta de recubrimiento de cable.

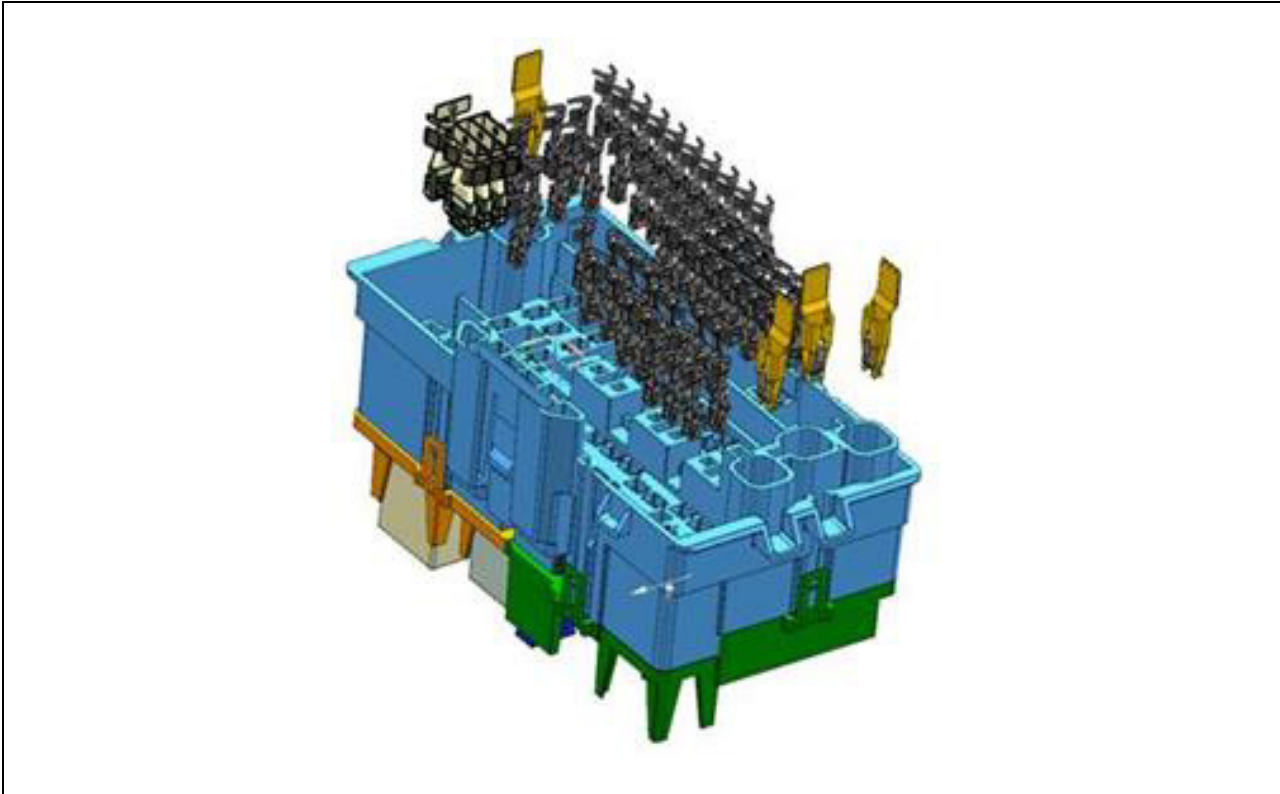

Retire las terminales de una en una utilizando el siguiente método.

ALL INFORMATION WITHIN ABOVE BORDER TO BE PRINTED EXACTLY AS SHOWN ON 8.5 x 11 WHITE 16 POUND NON-BOND RECYCLABLE PAPER. PRINT ON BOTH SIDES, EXCLUDING TEMPLATES. TO BE UNITIZED IN ACCORDANCE WITH GM SPECIFICATIONS.

DATE	REVISION	AUTH	DR
25MY17	Initial Release - Frank Lertz	N/A	

TITLE	<b>INSTALLATION INSTRUCTIONS Assembly / Disassembly Instructions</b>		
PART NO.	<b>23322679</b>	SHEET	<b>40</b> OF <b>84</b>

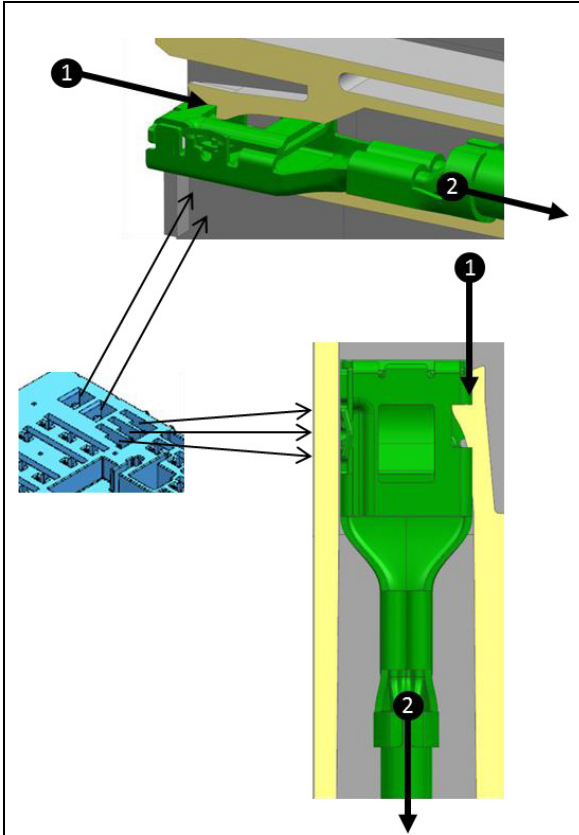

Terminal 630F (Relevador de logística).

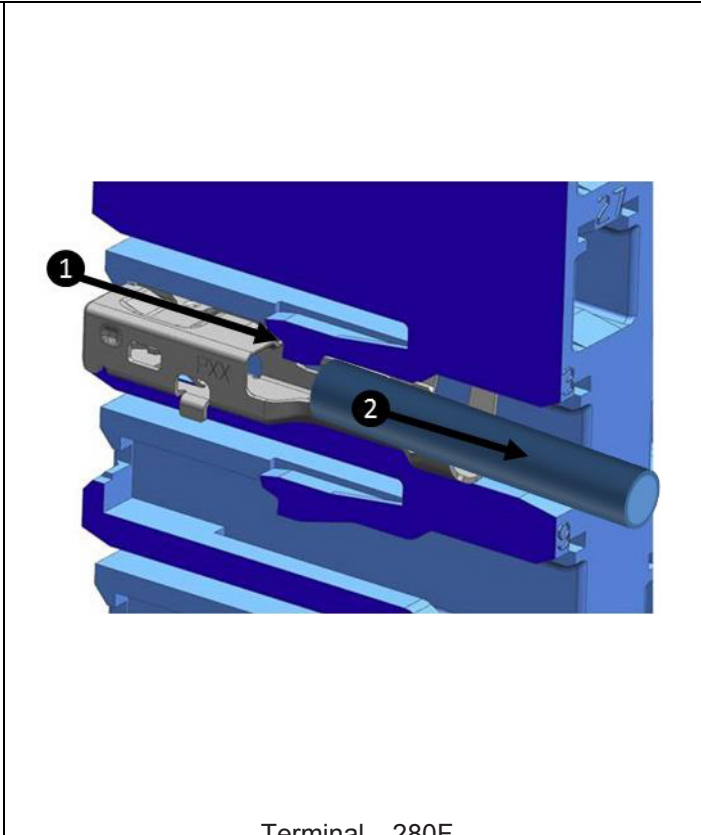

Terminal 280F  
(Fusibles, interruptores de servicio y relevadores).

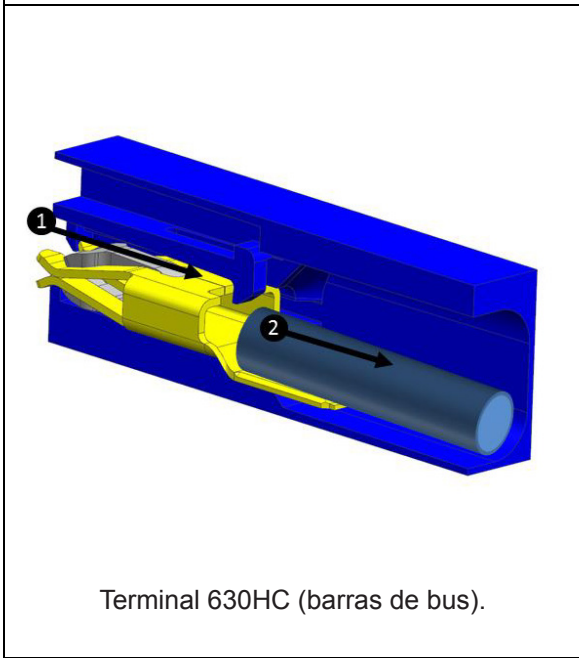

Terminal 630HC (barras de bus).

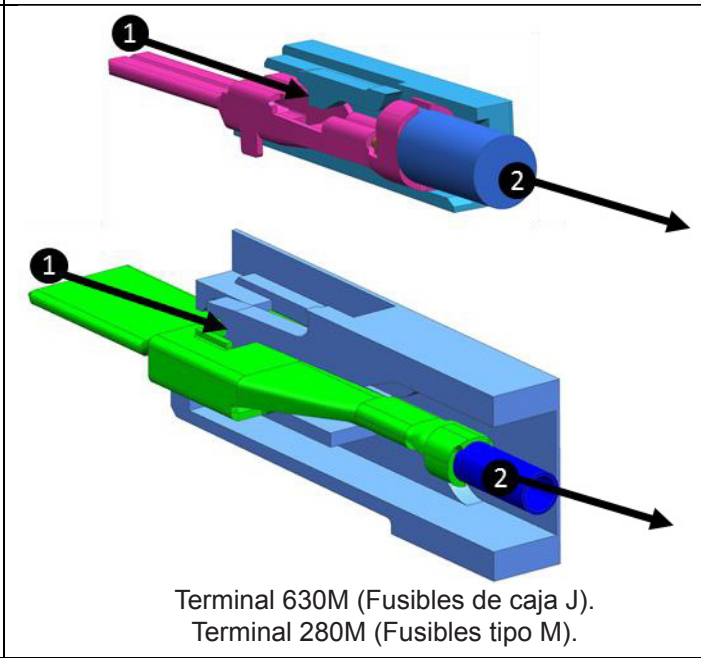

Terminal 630M (Fusibles de caja J).  
Terminal 280M (Fusibles tipo M).

**Secuencia de operaciones**

1. Localice la característica de bloqueo flexible en el alojamiento de plástico y levántela.
2. Jale el cable para extraer la terminal.

**Assembly / Disassembly Instructions**

IR 25MY17

PART NO.

**23322679**

SHEET

**41** OF **84**

ALL INFORMATION WITHIN ABOVE BORDER TO BE PRINTED EXACTLY AS SHOWN ON 8.5 x 11 WHITE 16 POUND NON-BOND RECYCLABLE PAPER. PRINT ON BOTH SIDES, EXCLUDING TEMPLATES. TO BE UNITIZED IN ACCORDANCE WITH GM SPECIFICATIONS.

DATE	REVISION	AUTH	DR
25MY17	Initial Release - Frank Lertiz	N/A	

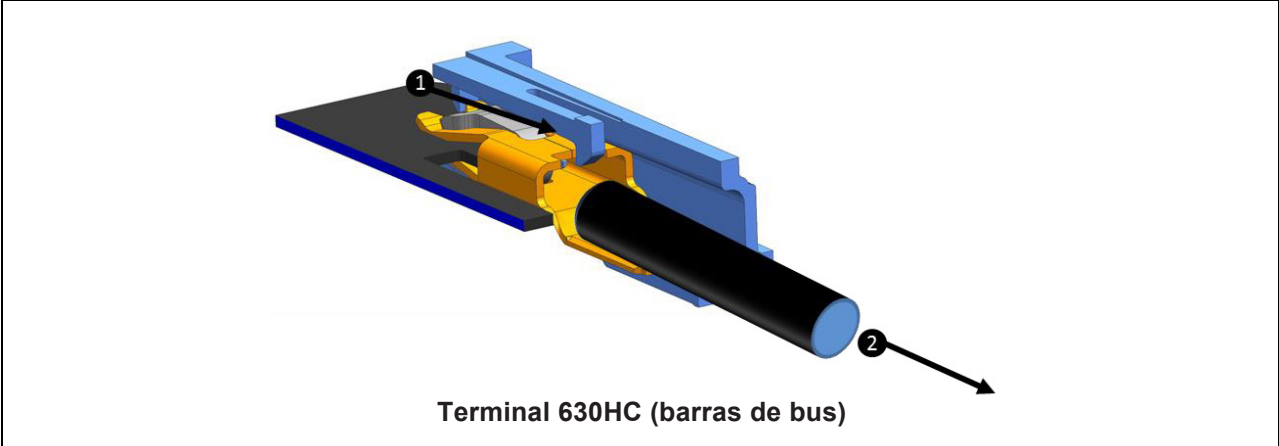

TITLE	PART NO.	SHEET
<b>INSTALLATION INSTRUCTIONS Assembly / Disassembly Instructions</b>	<b>23322679</b>	<b>41</b> OF <b>84</b>



**Terminal 630HC (barras de bus)**

- Secuencia de operaciones**
1. Localice la característica de bloqueo flexible en el alojamiento de plástico y levántela.
  2. Jale el cable para extraer la terminal.

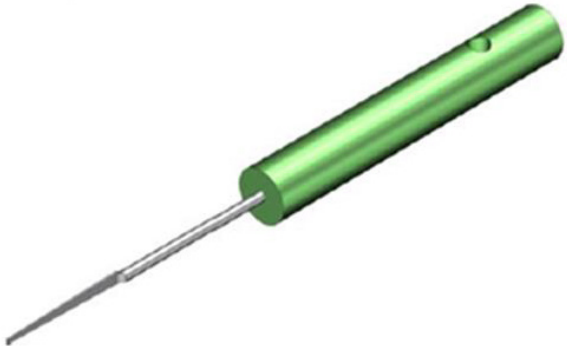
**Herramientas de reparación recomendadas**

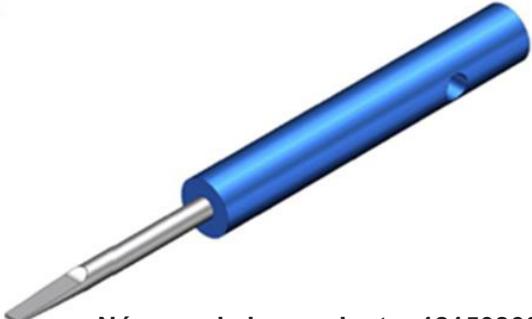
 <p>Número de herramienta: 12094430</p>	 <p>Número de herramienta: 12094441</p>
 <p>Número de herramienta: 12094429</p>	 <p>Número de herramienta: 12150860</p>

ALL INFORMATION WITHIN ABOVE BORDER TO BE PRINTED EXACTLY AS SHOWN ON 8.5 x 11 WHITE 16 POUND NON-BOND RECYCLABLE PAPER. PRINT ON BOTH SIDES, EXCLUDING TEMPLATES. TO BE UNITIZED IN ACCORDANCE WITH GM SPECIFICATIONS.

DATE	REVISION	AUTH	DR
25MY17	Initial Release - Frank Lertz	N/A	

组装 - 拆解说明

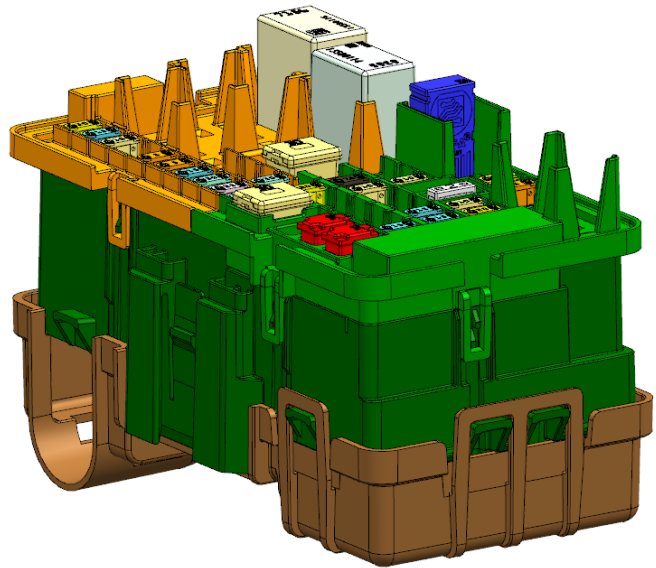
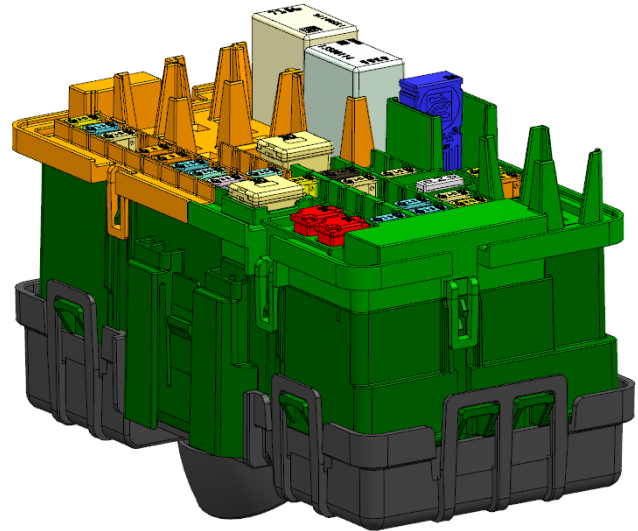

**Assembly / Disassembly Instructions**

**IR 25MY17**

PART NO.

**23322679**

SHEET

**43 OF 84**

ALL INFORMATION WITHIN ABOVE BORDER TO BE PRINTED EXACTLY AS SHOWN ON 8.5 x 11 WHITE 16 POUND NON-BOND RECYCLABLE PAPER. PRINT ON BOTH SIDES, EXCLUDING TEMPLATES. TO BE UNITIZED IN ACCORDANCE WITH GM SPECIFICATIONS.

DATE	REVISION	AUTH	DR
25MY17	Initial Release - Frank Lertz	N/A	

TITLE	<b>INSTALLATION INSTRUCTIONS Assembly / Disassembly Instructions</b>		
PART NO.	<b>23322679</b>	SHEET	<b>43 OF 84</b>

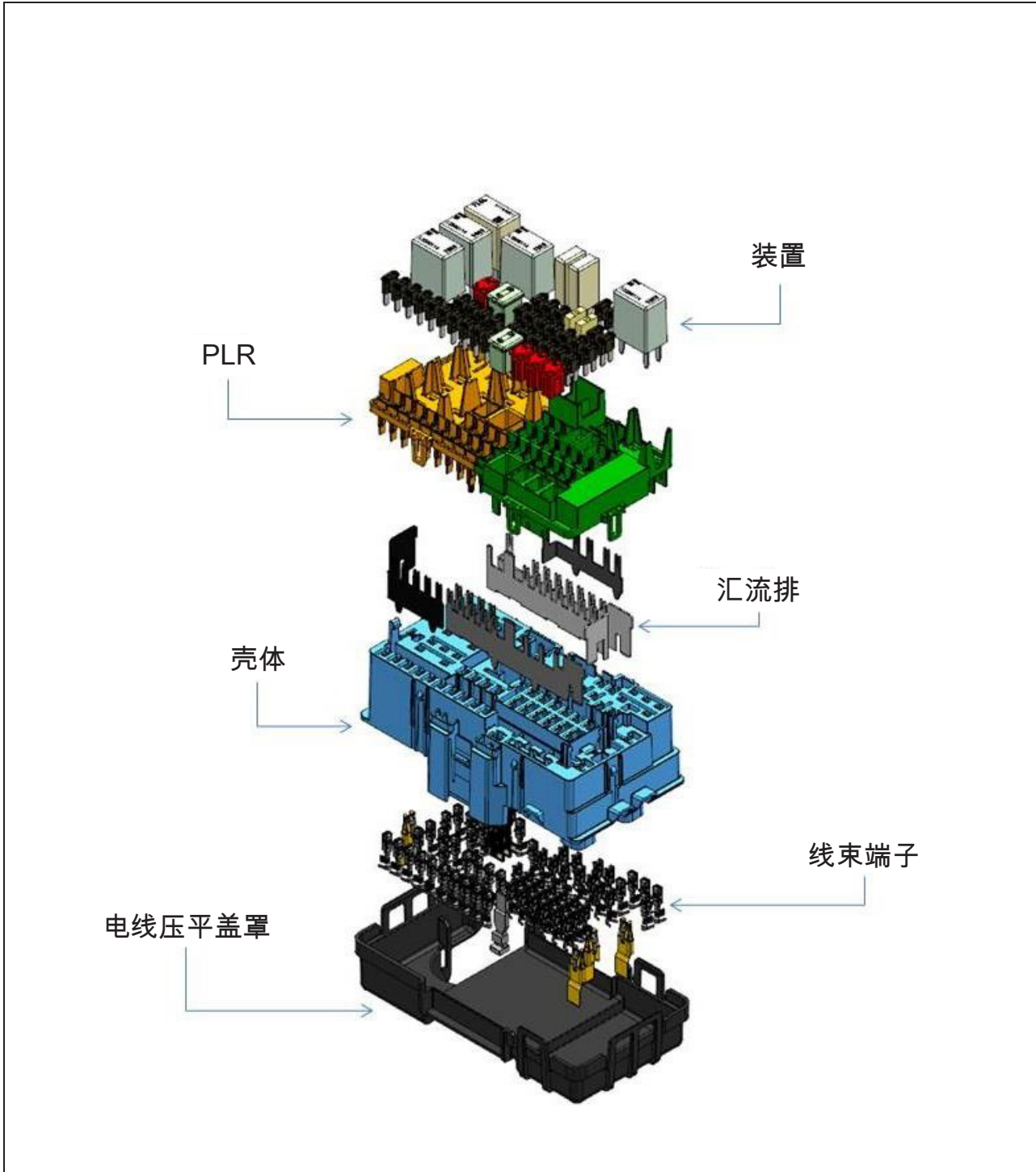

分解图



DATE	REVISION	AUTH	DR
25MY17	Initial Release - Frank Lertz	N/A	

TITLE
<b>INSTALLATION INSTRUCTIONS</b>
<b>Assembly / Disassembly Instructions</b>
PART NO.
<b>23322679</b>
SHEET
<b>44 OF 84</b>

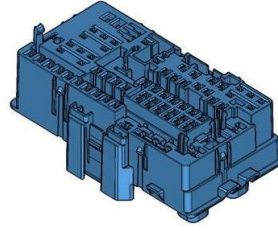
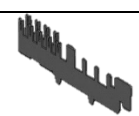
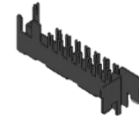
物料清单

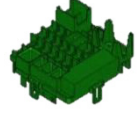
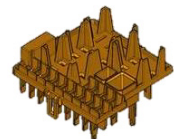
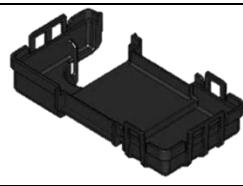
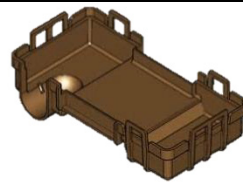
说明		PE零件号	8位数零件号	
壳体 - 汇流排 分总成 33272518	壳体	PE242429	33152669	
	汇流排	PE242426	33152670	
	汇流排	PE242427	33152672	
	汇流排	PE255013	33152673	
	汇流排	PE260273	33152674	
PLR		PE286899	33152676	
PLR		PE286900	33152677	
电线压平盖罩		PE242430	33152678	
电线压平盖罩		PE264537	33152679	

**Assembly / Disassembly Instructions**

**IR 25MY17**

PART NO.

**23322679**

SHEET **45** OF **84**

ALL INFORMATION WITHIN ABOVE BORDER TO BE PRINTED EXACTLY AS SHOWN ON 8.5 x 11 WHITE 16 POUND NON-BOND RECYCLABLE PAPER. PRINT ON BOTH SIDES, EXCLUDING TEMPLATES. TO BE UNITIZED IN ACCORDANCE WITH GM SPECIFICATIONS.

DATE	REVISION	AUTH	DR
25MY17	Initial Release - Frank Lertz	N/A	

TITLE
<b>INSTALLATION INSTRUCTIONS Assembly / Disassembly Instructions</b>
PART NO. <b>23322679</b> SHEET <b>45</b> OF <b>84</b>

腔孔标号

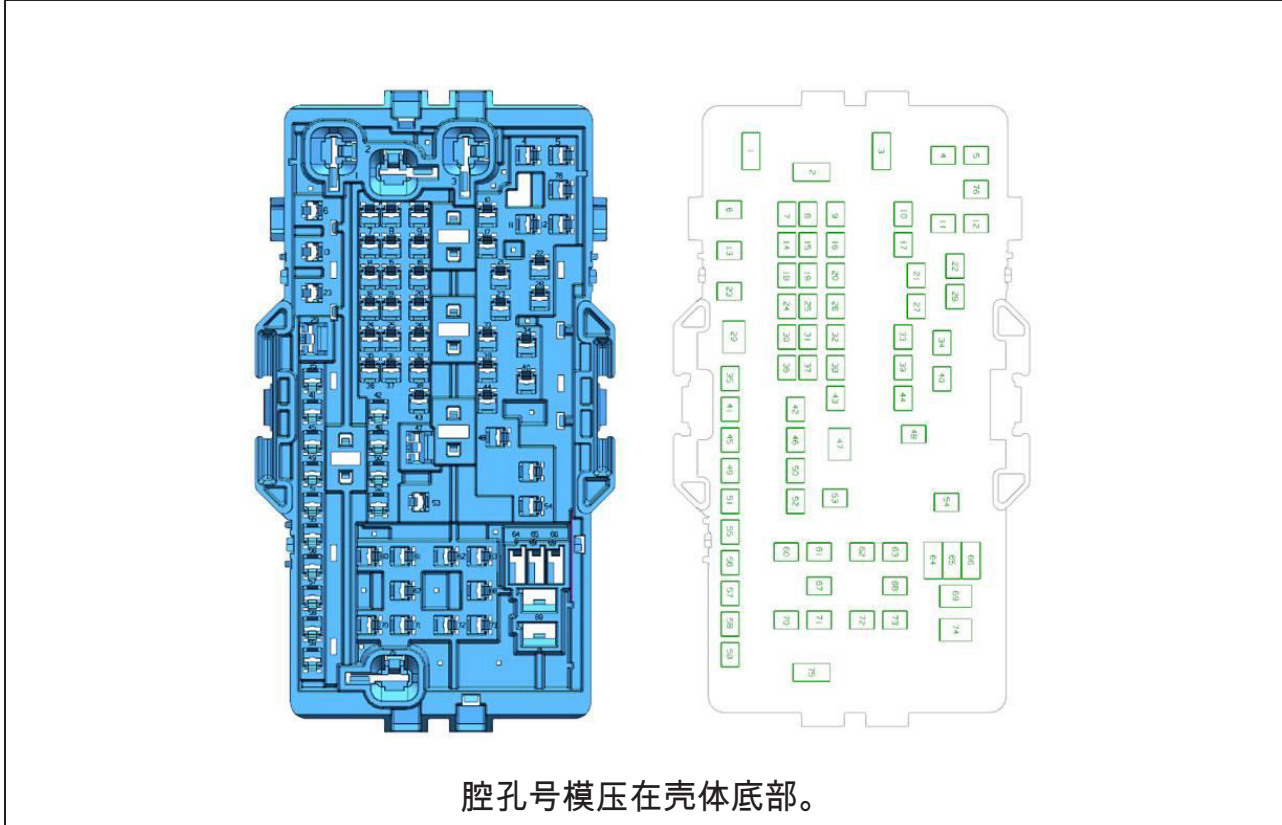

腔孔号模压在壳体底部。

CAVITY INFORMATION			
CAVITY NAME	TERMINAL	DESCRIPTION	TYPICAL USE
1, 2, 3, 75	13979887	630 ASM F TERMINAL AG	BUSS BARS
4, 5, 7, 8, 9, 10, 11, 12, 14, 15, 16, 17, 18, 19, 20, 21, 22, 24, 25, 26, 27, 28, 30, 31, 32, 33, 34, 35, 36, 37, 38, 39, 40, 41, 42, 43, 44, 45, 46, 48, 49, 50, 51, 52, 54, 55, 56, 57, 58, 59, 60, 61, 62, 63, 67, 68, 70, 71, 72, 73, 76, 77	13849936	280 OCS F TERMINAL	RELAYS AND FUSES
6, 13, 23, 53	10725700	280 M TERMINAL	M-TYPE FUSE
29, 74	10725704	630 M TERMINAL	J-CASE FUSE
64, 65, 66, 69, 74	15344770	630 RELAY TERMINAL	LOGISTICS RELAY

腔孔号对应腔孔类型的参考表

DATE	REVISION	AUTH	DR
25MY17	Initial Release - Frank Lertiz	N/A	

TITLE
<b>INSTALLATION INSTRUCTIONS</b> <b>Assembly / Disassembly Instructions</b>
PART NO. <b>23322679</b> SHEET <b>46</b> OF <b>84</b>

端子插入

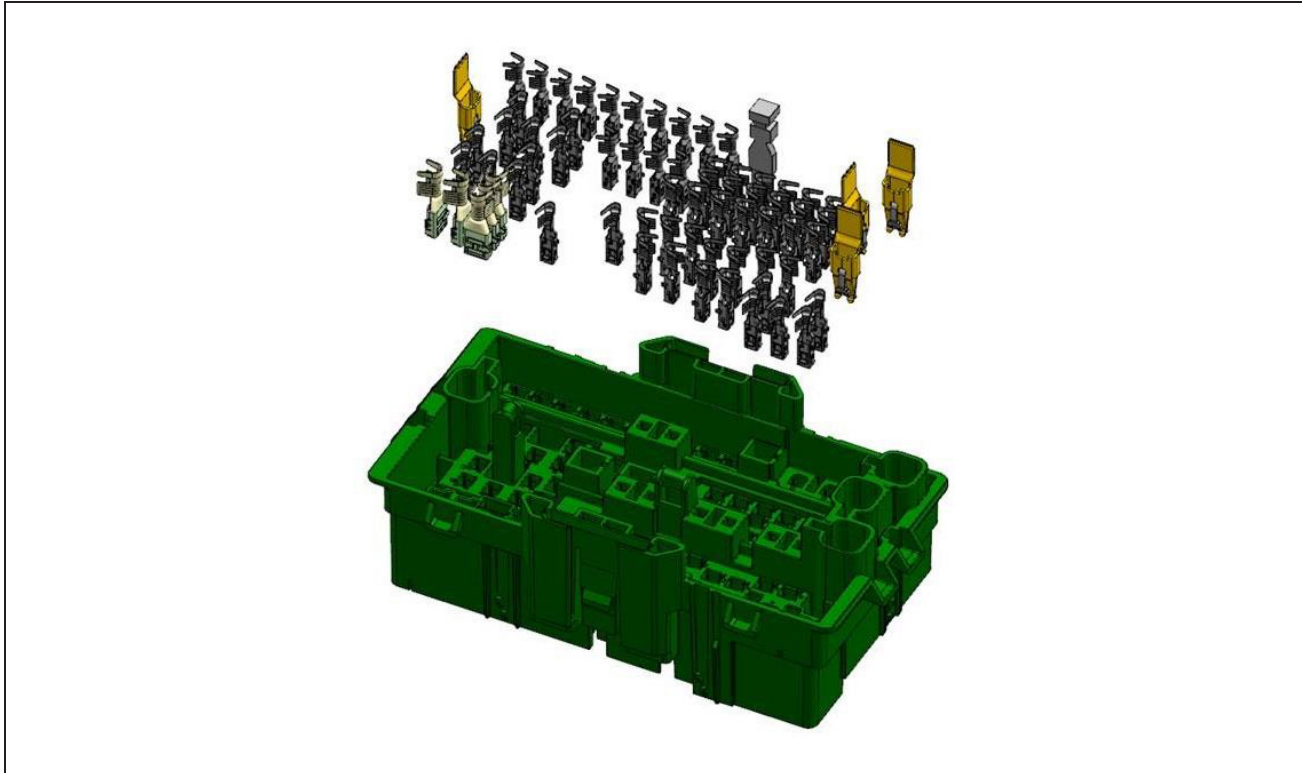

插入端子，使其底部位于相应的腔孔内。（参见上页表格）

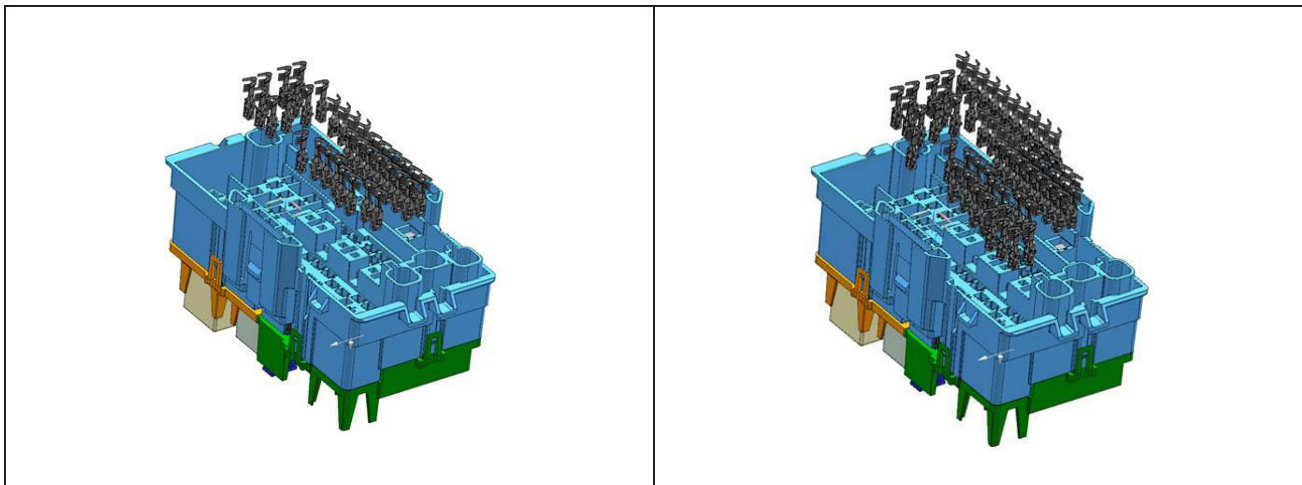

DATE	REVISION	AUTH	DR
25MY17	Initial Release - Frank Lertz	N/A	

TITLE	<b>INSTALLATION INSTRUCTIONS Assembly / Disassembly Instructions</b>		
PART NO.	<b>23322679</b>	SHEET	<b>47</b> OF <b>84</b>

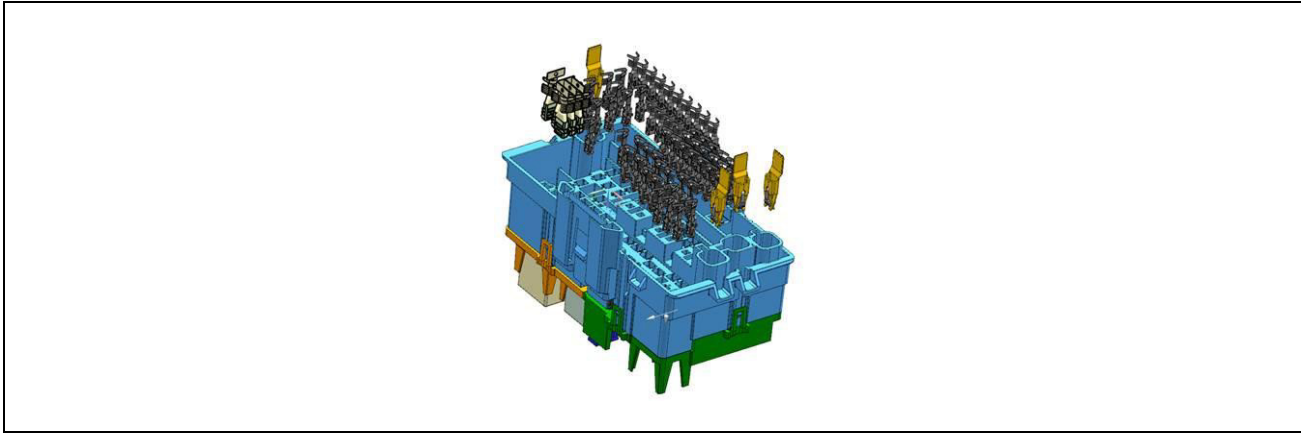

从壳体中间开始插入端子，然后再向两边插



将端子插入主腔体中

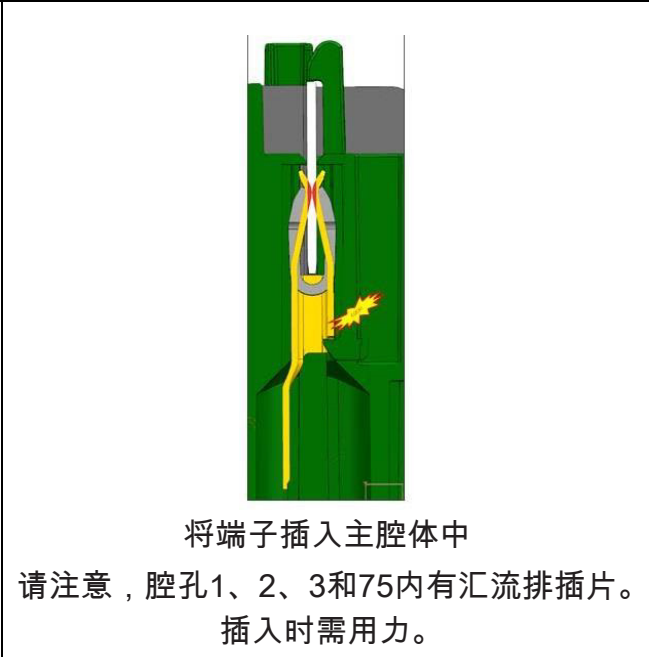

将端子插入主腔体中  
 请注意，腔孔1、2、3和75内有汇流排插片。  
 插入时需用力。

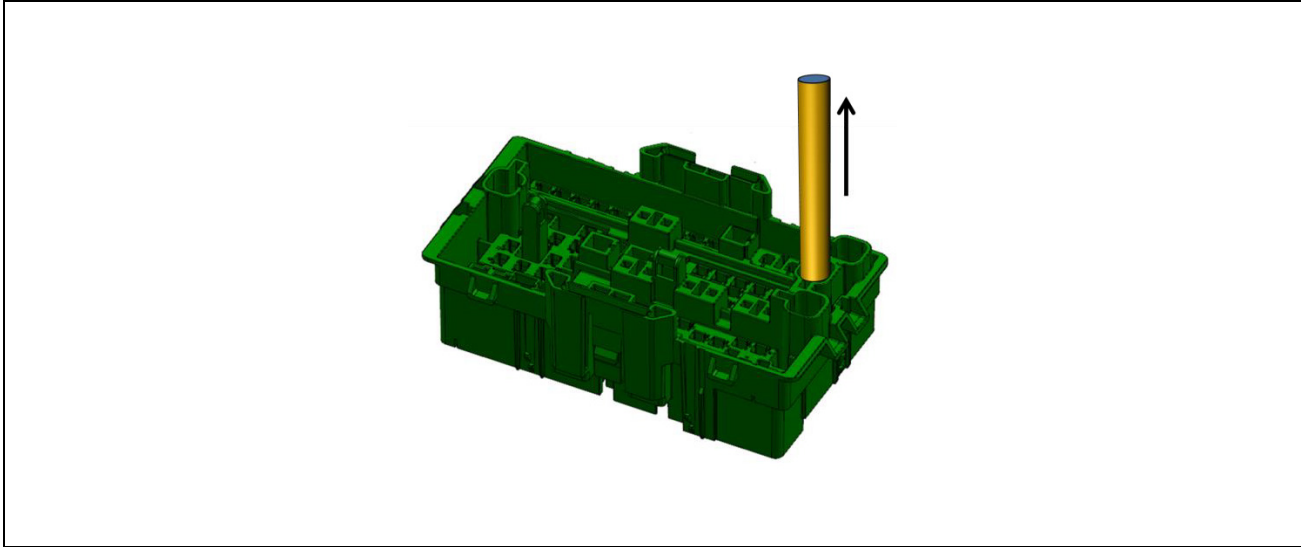

每次插入后，轻轻拉动线缆以确认锁定系统工作正常

ALL INFORMATION WITHIN ABOVE BORDER TO BE PRINTED EXACTLY AS SHOWN ON 8.5 x 11 WHITE 16 POUND NON-BOND RECYCLABLE PAPER. PRINT ON BOTH SIDES, EXCLUDING TEMPLATES. TO BE UNITIZED IN ACCORDANCE WITH GM SPECIFICATIONS.

DATE	REVISION	AUTH	DR
25MY17	Initial Release - Frank Lertz	N/A	

<b>INSTALLATION INSTRUCTIONS</b> <b>Assembly / Disassembly Instructions</b>	
PART NO. <b>23322679</b>	SHEET <b>48</b> OF <b>84</b>

放置 PLR

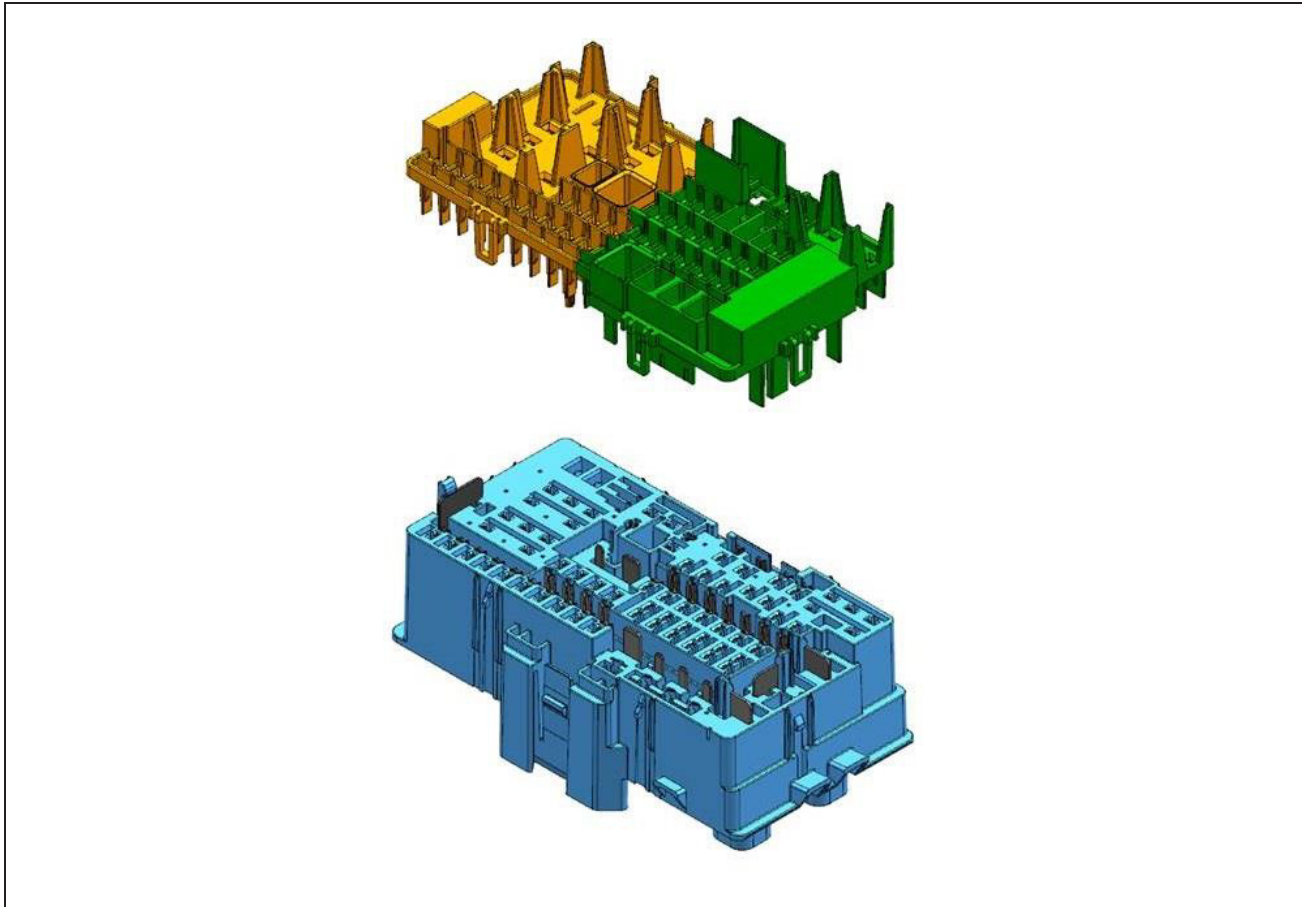

PLR ( 两个 ) 可依次组装。无特定组装顺序。

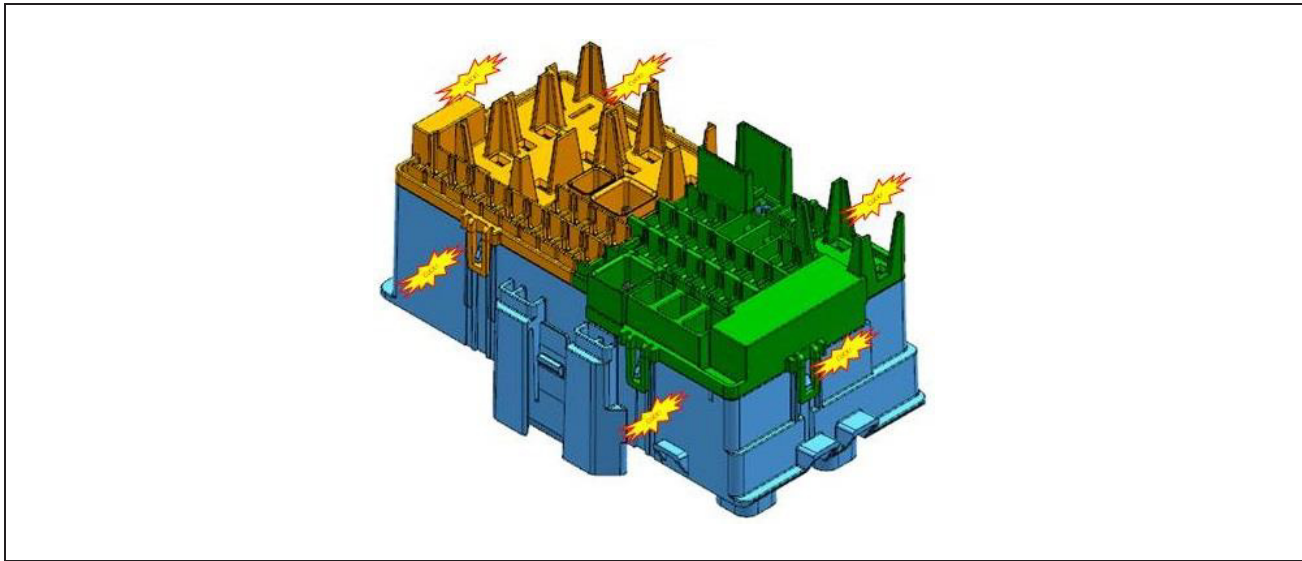

将PLR完全按入壳体内，直至听到一声咔嚓声。  
可能需要机械辅助工具。

DATE	REVISION	AUTH	DR
25MY17	Initial Release - Frank Lertz	N/A	

TITLE	PART NO.	SHEET
<b>INSTALLATION INSTRUCTIONS Assembly / Disassembly Instructions</b>	<b>23322679</b>	<b>49 OF 84</b>

插入装置

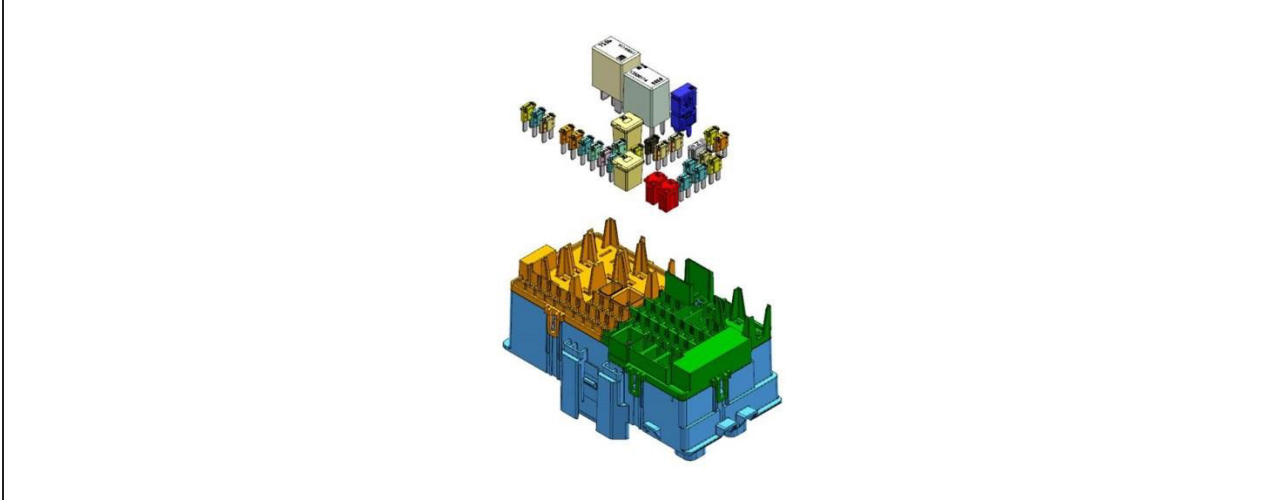

根据各型号需求插入保险丝和继电器。

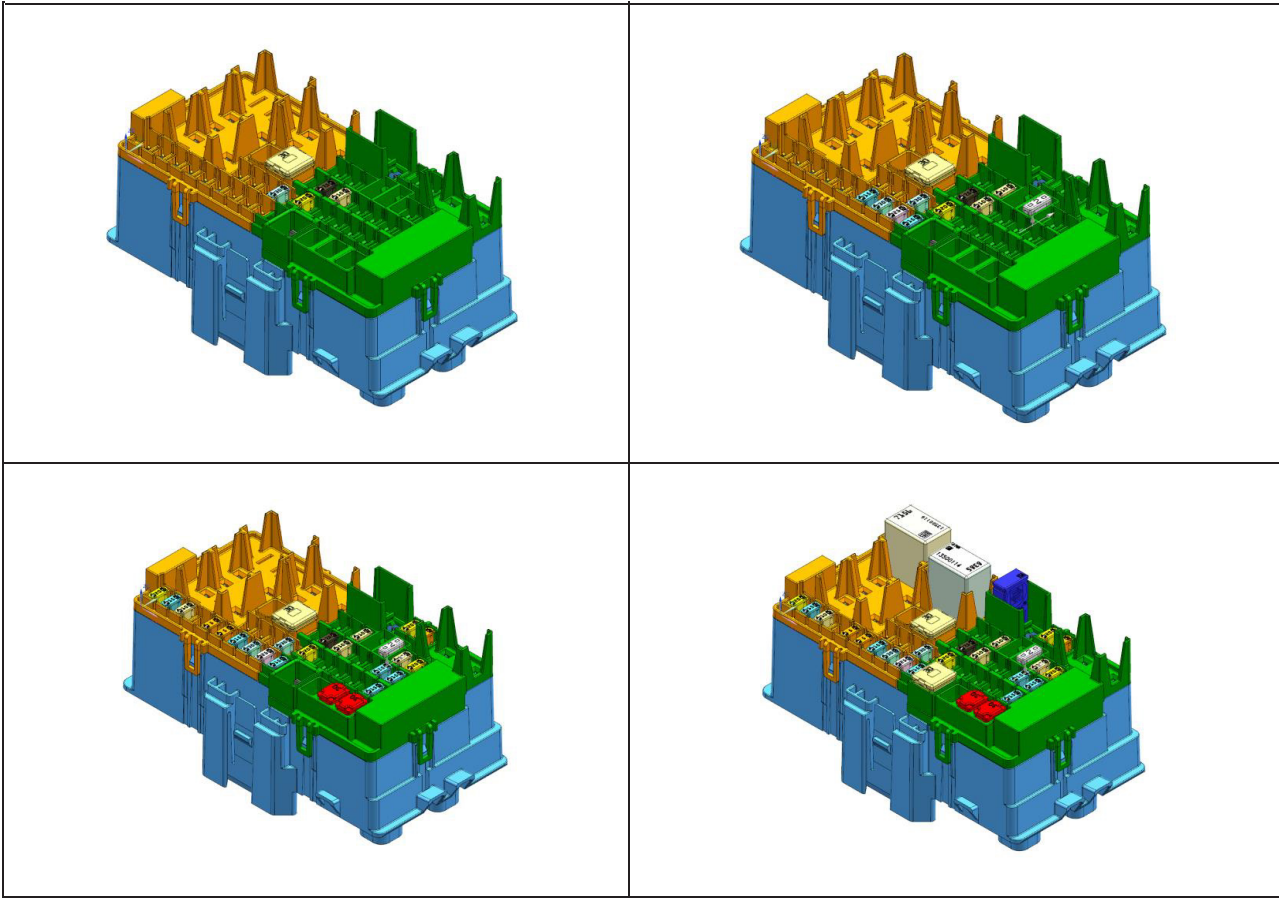

先插入断面最低且位于壳体中心的装置。  
然后接着插入断面较高的装置。与端子一样，从壳体中心开始插入。

DATE	REVISION	AUTH	DR
25MY17	Initial Release - Frank Lertz	N/A	

TITLE	<b>INSTALLATION INSTRUCTIONS</b>		
	<b>Assembly / Disassembly Instructions</b>		
PART NO.	<b>23322679</b>	SHEET	<b>50</b> OF <b>84</b>

**放置电线压平盖罩**

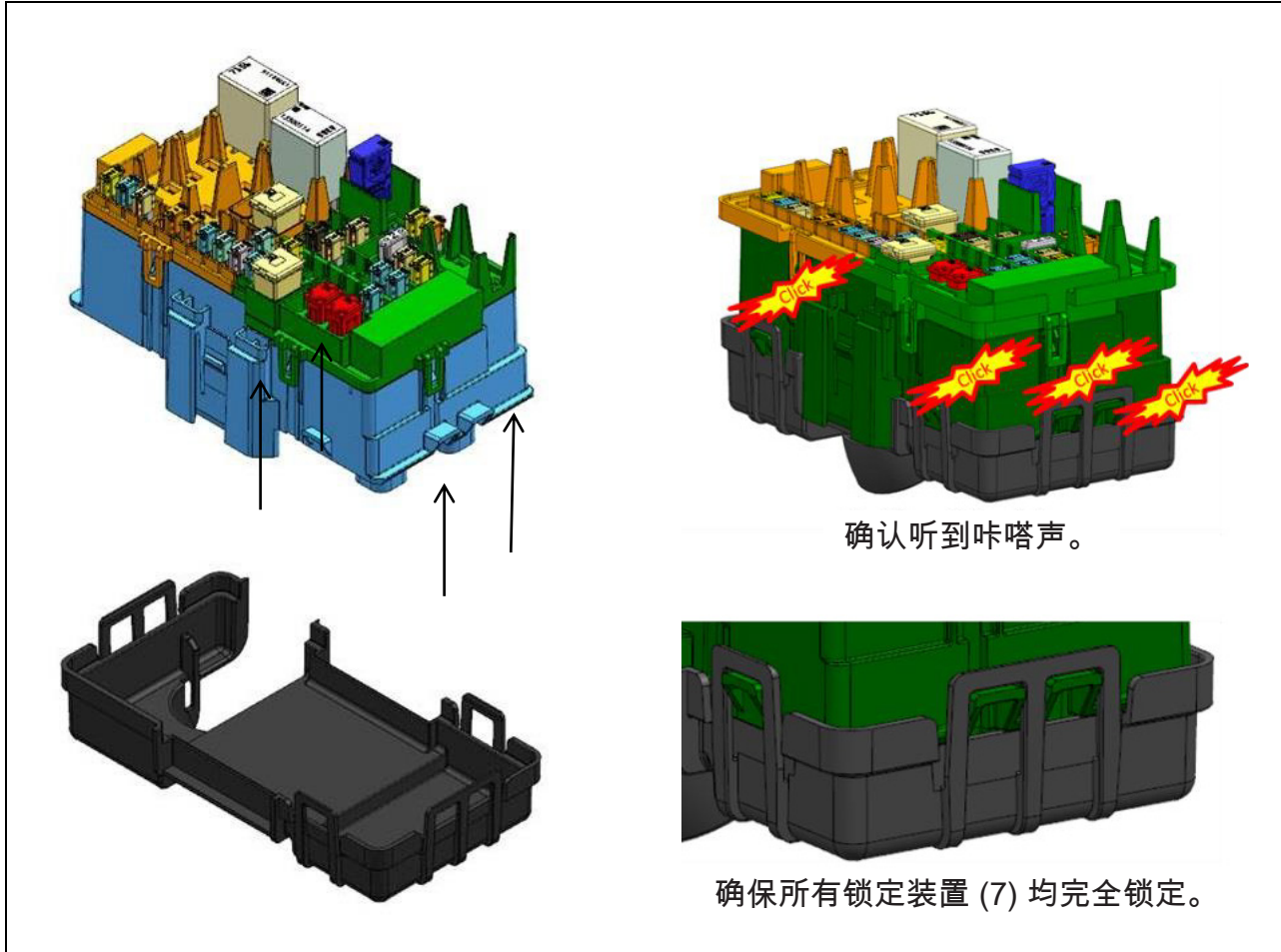

确认听到咔嗒声。

确保所有锁定装置 (7) 均完全锁定。

将线缆弯曲到所需的线束布设位置。  
根据型号固定相应的电线压平盖罩，并将线束束带插入随附的槽内。

DATE	REVISION	AUTH	DR
25MY17	Initial Release - Frank Lertz	N/A	

<b>INSTALLATION INSTRUCTIONS</b>	
<b>Assembly / Disassembly Instructions</b>	
PART NO.	<b>23322679</b>
SHEET	<b>51 OF 84</b>

拆解电气中心

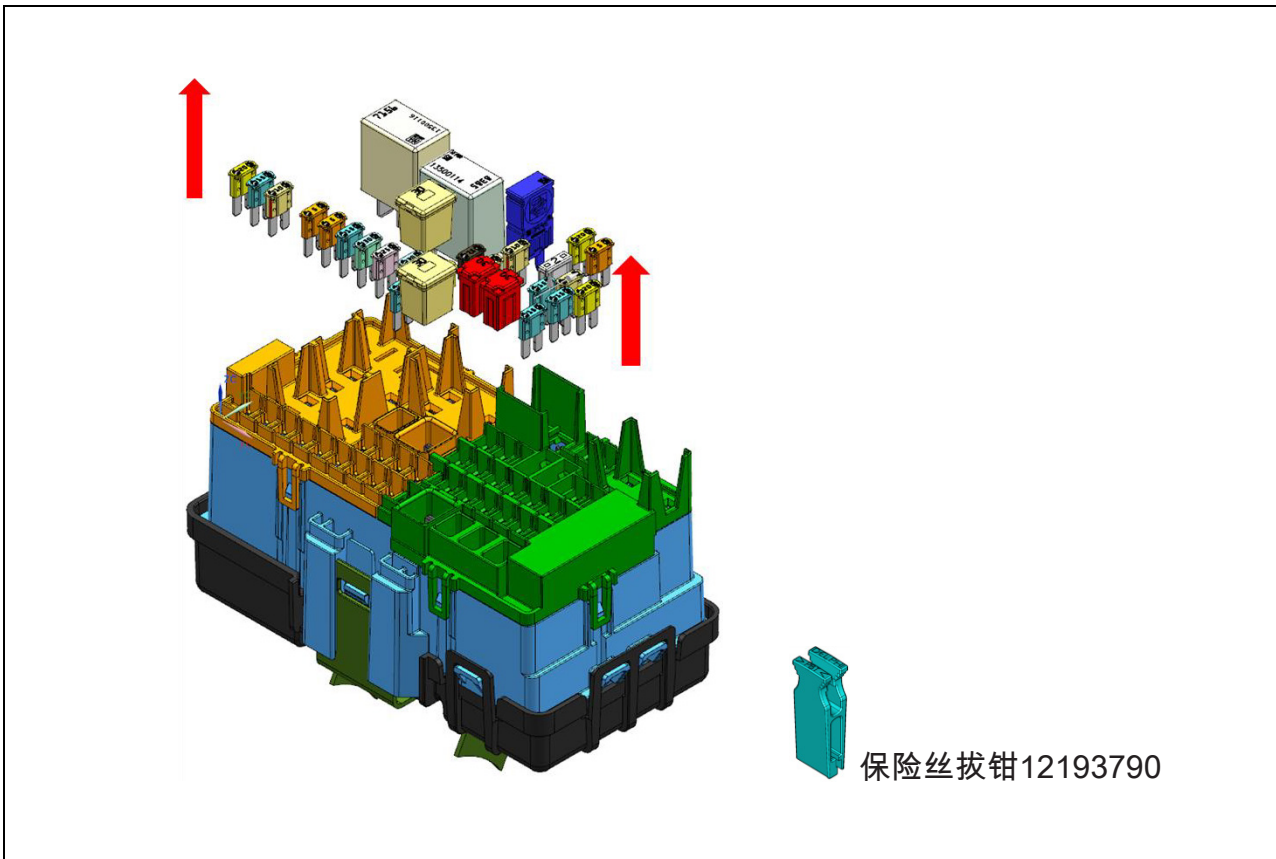

拆下所有装置。使用Delphi保险丝拔钳12193790 (推荐) 进行拆卸。

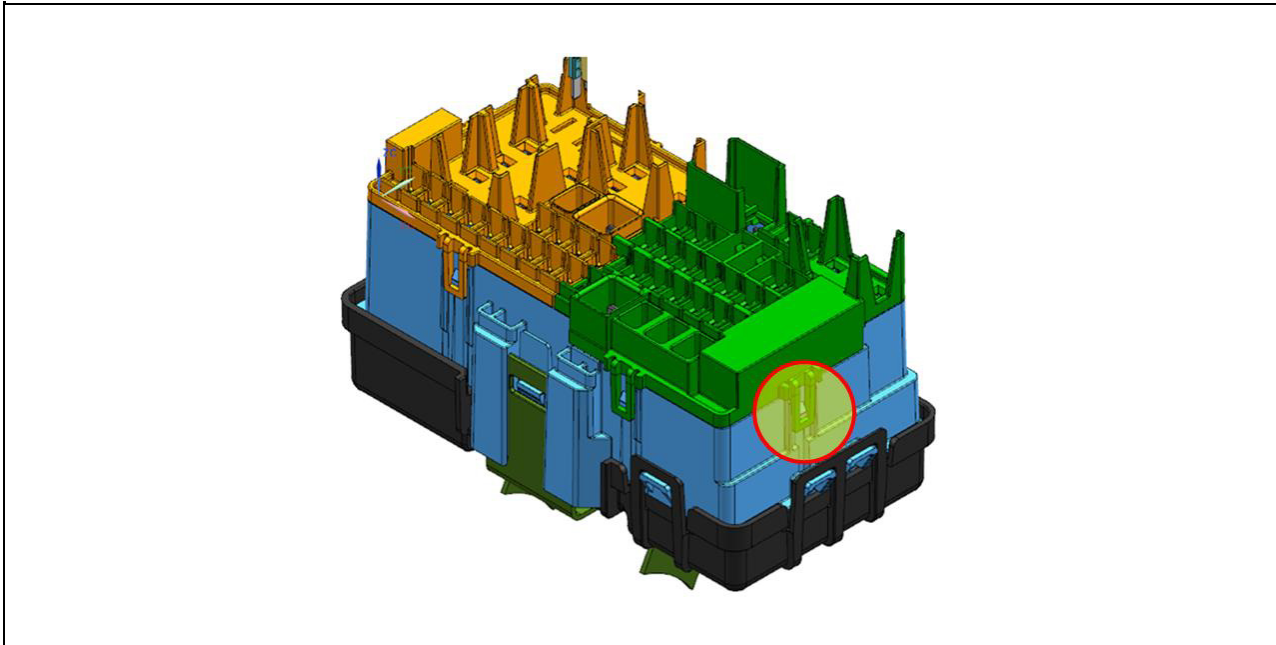

提起PLR锁定装置。  
作业过程中锁定装置可能会断裂。准备好备件。

DATE	REVISION	AUTH	DR
25MY17	Initial Release - Frank Lertz	N/A	

TITLE	PART NO.	SHEET
INSTALLATION INSTRUCTIONS Assembly / Disassembly Instructions	23322679	52 OF 84

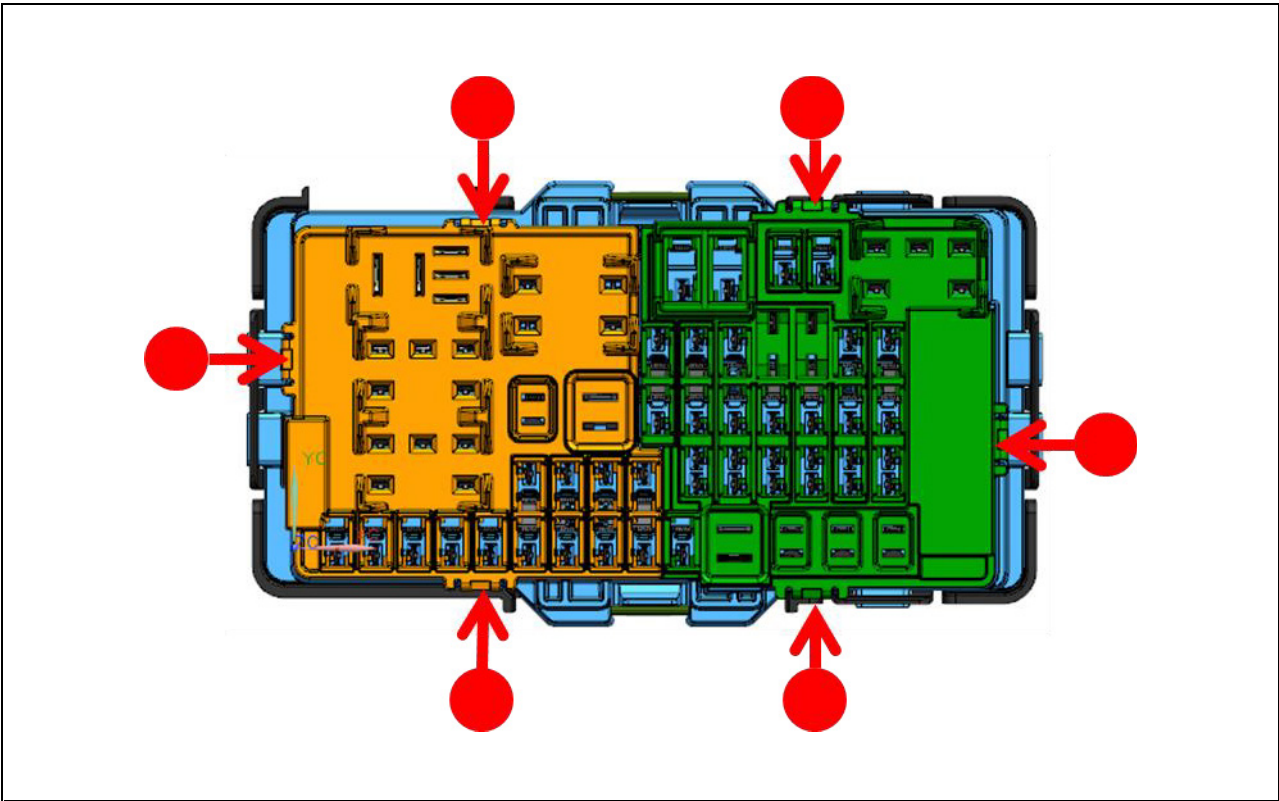

每个PLR有3个或3个以上锁定装置，位于红色圆圈和箭头所示位置或附近。

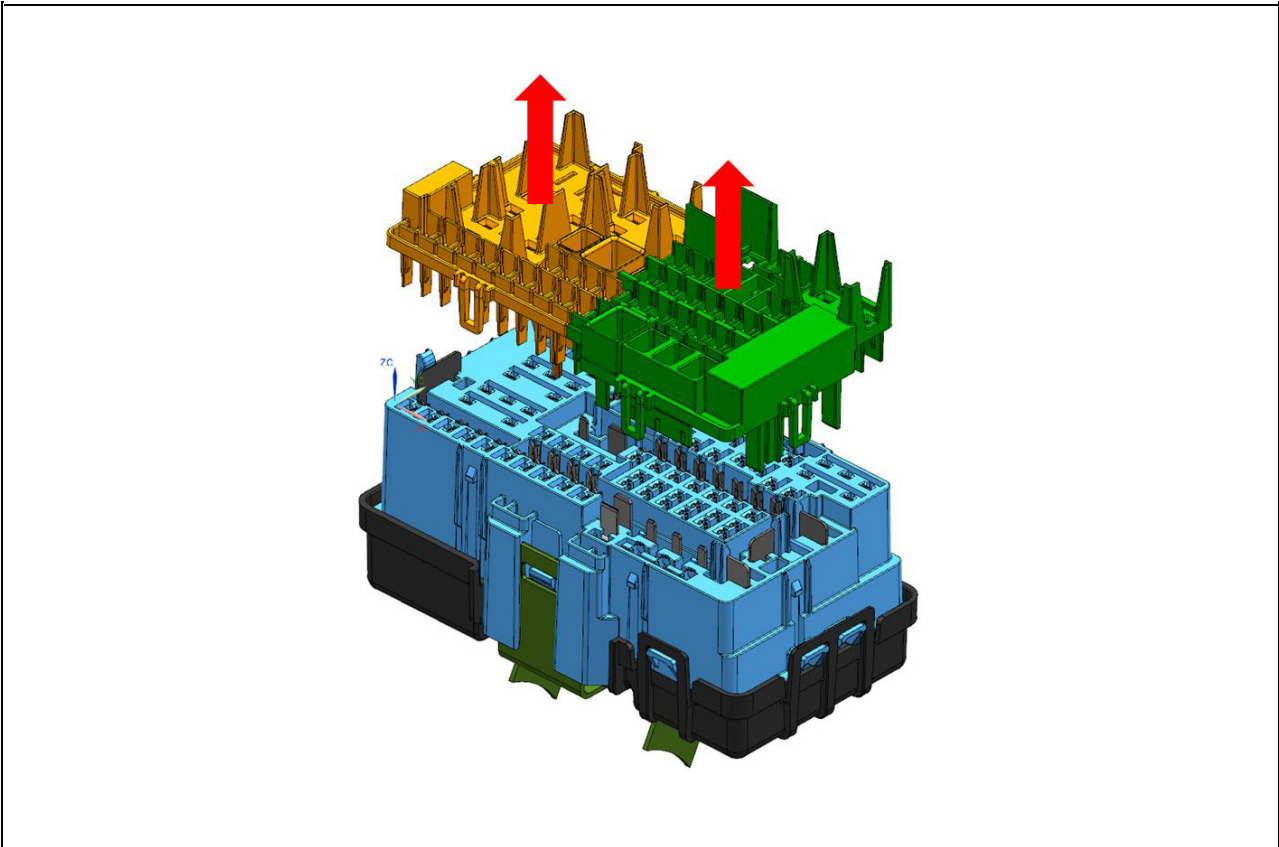

拆卸PLR

Assembly / Disassembly Instructions

IR 25MY17

PART NO.

23322679

SHEET

53 OF 84

ALL INFORMATION WITHIN ABOVE BORDER TO BE PRINTED EXACTLY AS SHOWN ON 8.5 x 11 WHITE 16 POUND NON-BOND RECYCLABLE PAPER. PRINT ON BOTH SIDES, EXCLUDING TEMPLATES. TO BE UNITIZED IN ACCORDANCE WITH GM SPECIFICATIONS.

DATE	REVISION	AUTH	DR
25MY17	Initial Release - Frank Lertz	N/A	

TITLE
INSTALLATION INSTRUCTIONS Assembly / Disassembly Instructions
PART NO. 23322679
SHEET 53 OF 84

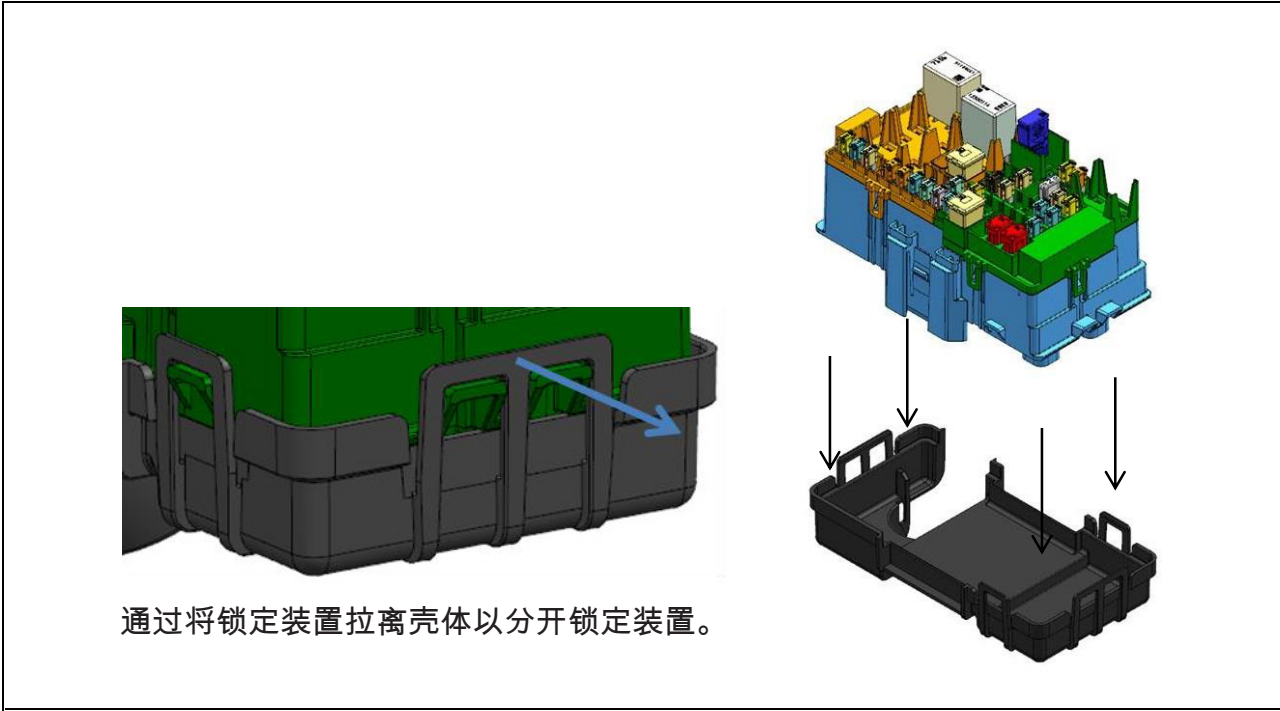

通过将锁定装置拉离壳体以分开锁定装置。

拆下电线压平盖罩。

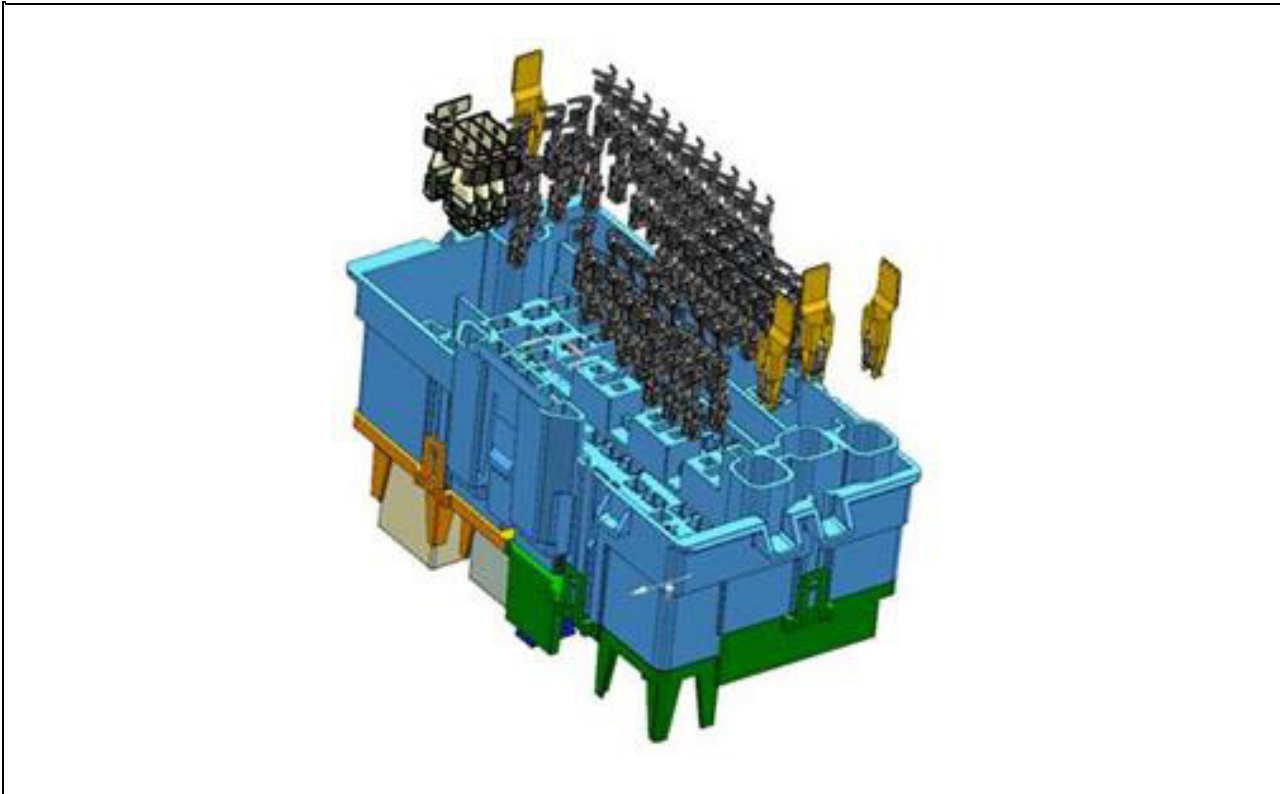

使用以下方法逐个拆下端子。

ALL INFORMATION WITHIN ABOVE BORDER TO BE PRINTED EXACTLY AS SHOWN ON 8.5 x 11 WHITE 16 POUND NON-BOND RECYCLABLE PAPER. PRINT ON BOTH SIDES, EXCLUDING TEMPLATES. TO BE UNITIZED IN ACCORDANCE WITH GM SPECIFICATIONS.

DATE	REVISION	AUTH	DR
25MY17	Initial Release - Frank Lertz	N/A	

TITLE	<b>INSTALLATION INSTRUCTIONS</b>		
	<b>Assembly / Disassembly Instructions</b>		
PART NO.	<b>23322679</b>	SHEET	<b>54</b> OF <b>84</b>

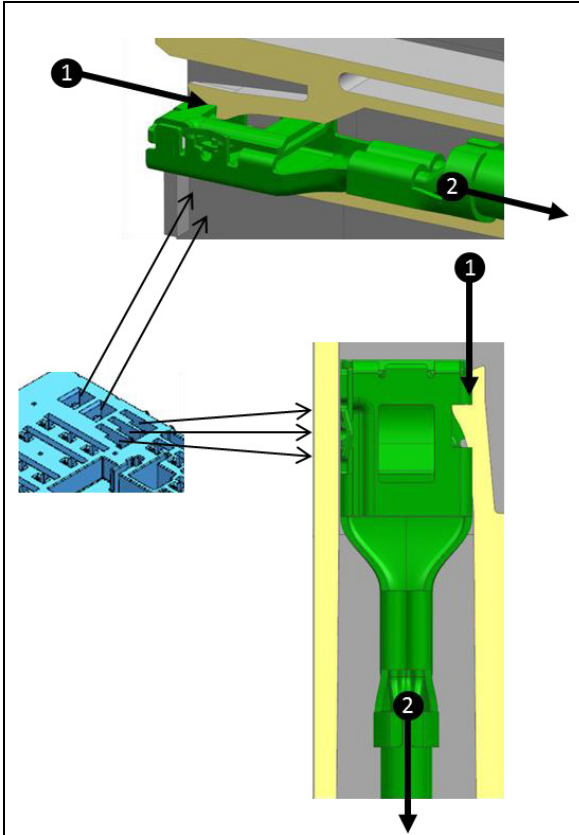

630F端子 ( 逻辑继电器 )。

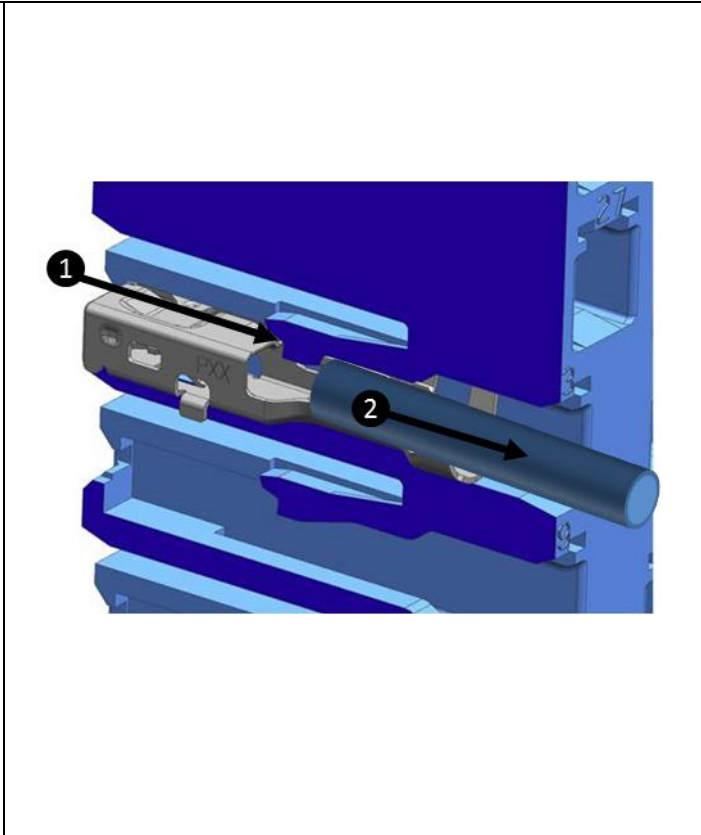

280F端子 ( 保险丝、断路器和继电器 )。

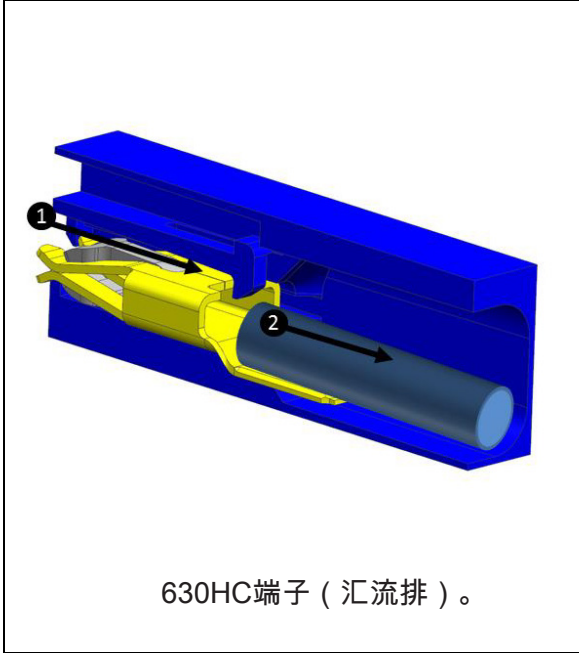

630HC端子 ( 汇流排 )。

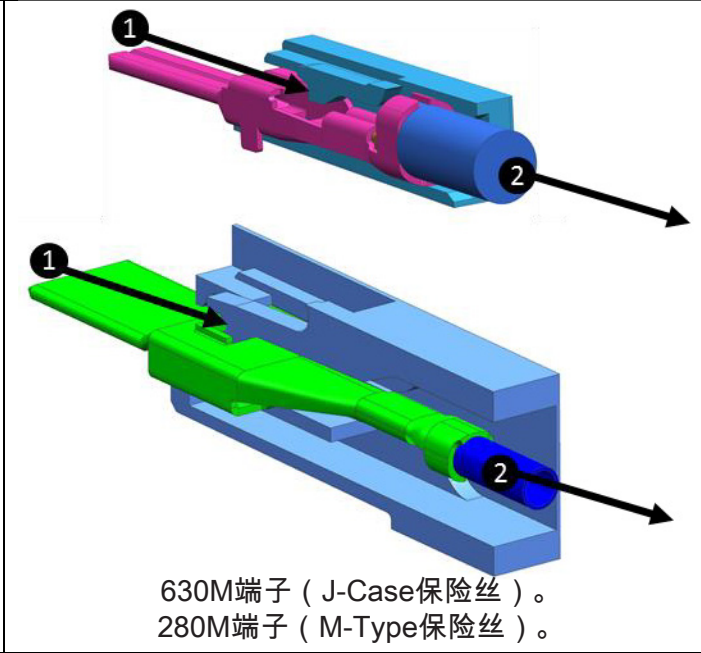

630M端子 ( J-Case保险丝 )。  
280M端子 ( M-Type保险丝 )。

**作业顺序**

1. 在塑料壳内找到柔性锁止装置并将其提起。
2. 拉动线缆以取出端子。

**Assembly / Disassembly Instructions**

IR 25MY17 PART NO. **23322679** SHEET **55** OF **84**

ALL INFORMATION WITHIN ABOVE BORDER TO BE PRINTED EXACTLY AS SHOWN ON 8.5 x 11 WHITE 16 POUND NON-BOND RECYCLABLE PAPER. PRINT ON BOTH SIDES, EXCLUDING TEMPLATES. TO BE UNITIZED IN ACCORDANCE WITH GM SPECIFICATIONS.

DATE	REVISION	AUTH	DR
25MY17	Initial Release - Frank Lertz	N/A	

<b>INSTALLATION INSTRUCTIONS</b>	
<b>Assembly / Disassembly Instructions</b>	
PART NO.	<b>23322679</b> SHEET <b>55</b> OF <b>84</b>

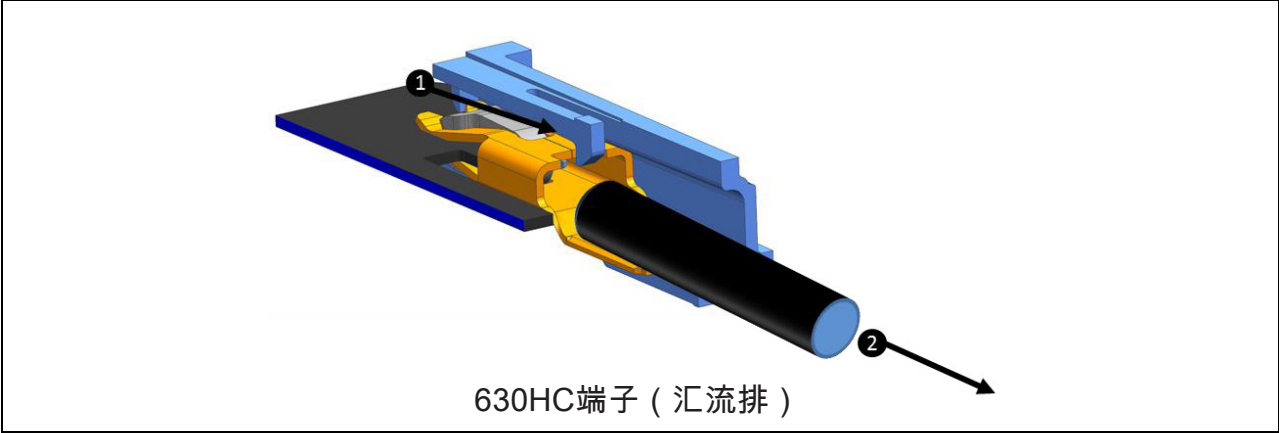

630HC端子 ( 汇流排 )

作业顺序

1. 在塑料壳内找到柔性锁止装置并将其提起。
2. 拉动线缆以取出端子。

推荐的修理工具

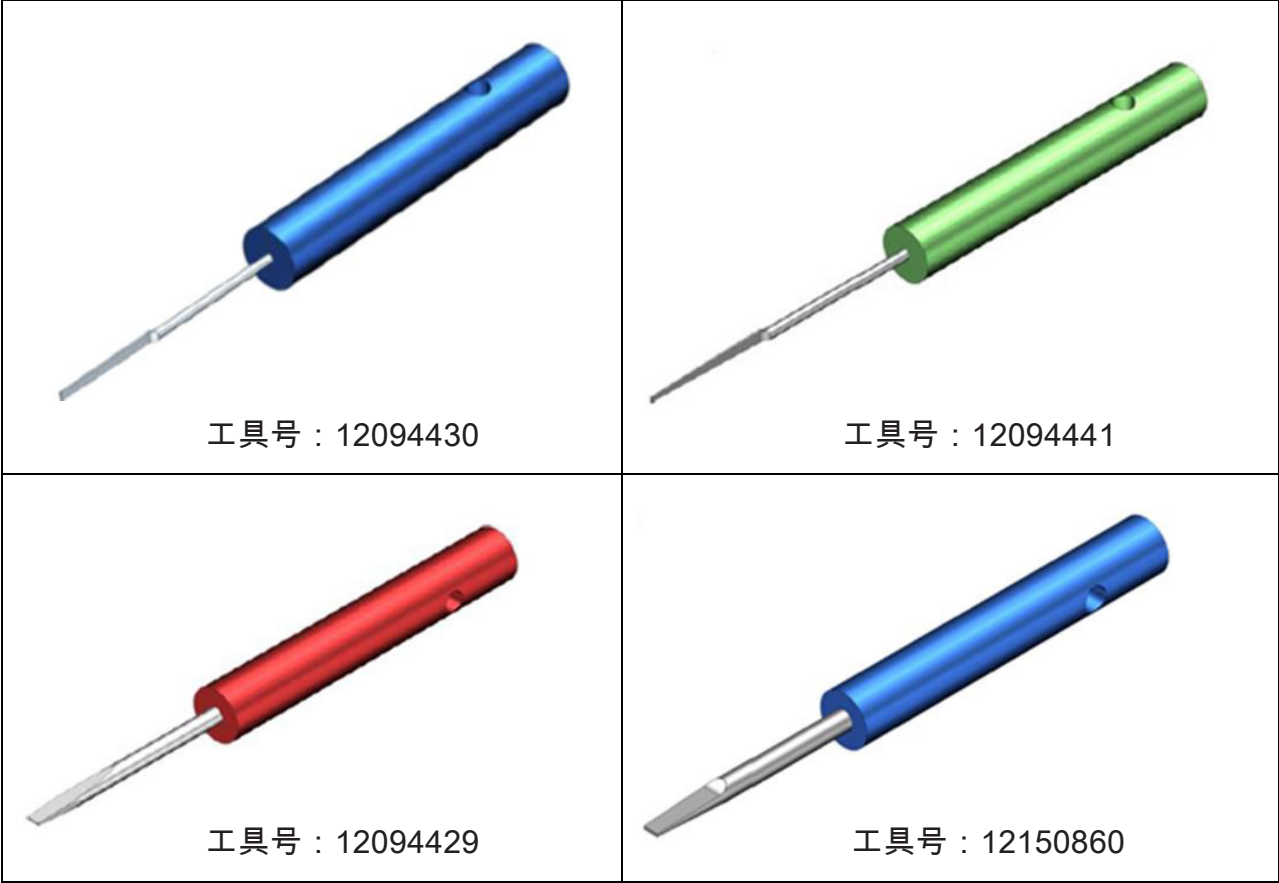

工具号 : 12094430

工具号 : 12094441

工具号 : 12094429

工具号 : 12150860

DATE	REVISION	AUTH	DR
25MY17	Initial Release - Frank Lertz	N/A	

TITLE	INSTALLATION INSTRUCTIONS Assembly / Disassembly Instructions		
PART NO.	23322679	SHEET	56 OF 84

조립 - 분해 지침

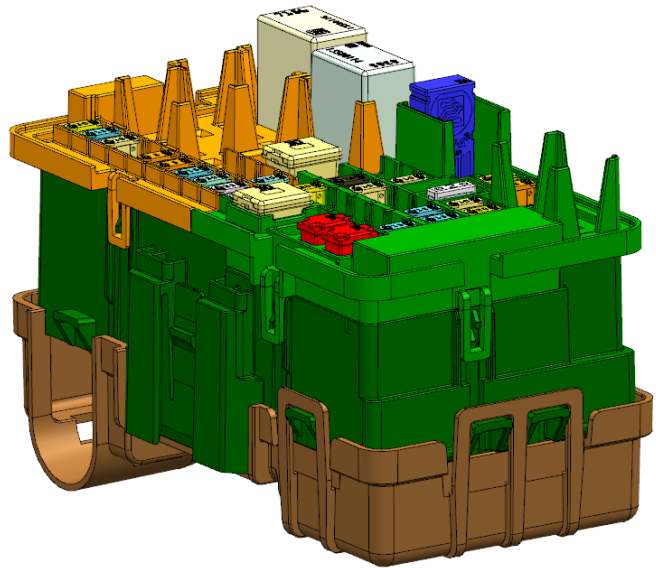
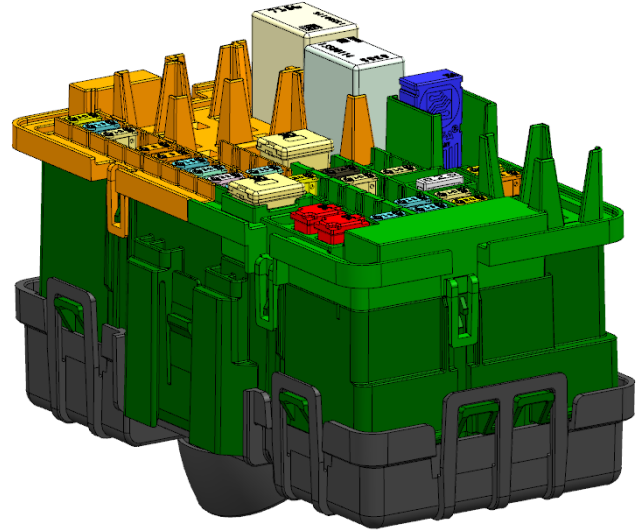

**Assembly / Disassembly Instructions**

**IR 25MY17**

PART NO.

**23322679**

SHEET **57** OF **84**

ALL INFORMATION WITHIN ABOVE BORDER TO BE PRINTED EXACTLY AS SHOWN ON 8.5 x 11 WHITE 16 POUND NON-BOND RECYCLABLE PAPER. PRINT ON BOTH SIDES, EXCLUDING TEMPLATES. TO BE UNITIZED IN ACCORDANCE WITH GM SPECIFICATIONS.

DATE	REVISION	AUTH	DR
25MY17	Initial Release - Frank Lertz	N/A	

TITLE	<b>INSTALLATION INSTRUCTIONS Assembly / Disassembly Instructions</b>		
PART NO.	<b>23322679</b>	SHEET	<b>57</b> OF <b>84</b>

분해도

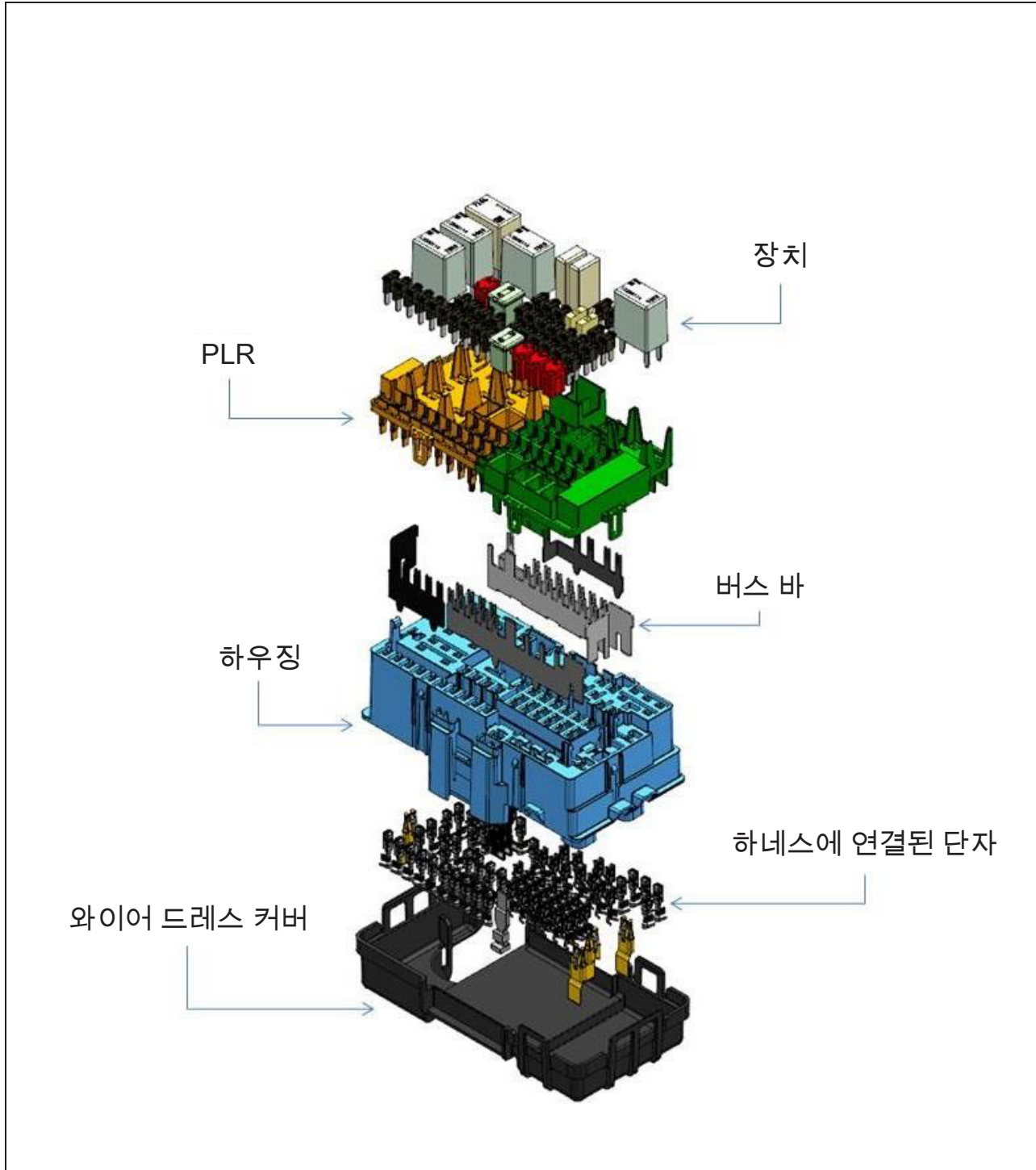

DATE	REVISION	AUTH	DR	TITLE
25MY17	Initial Release - Frank Lertz	N/A		INSTALLATION INSTRUCTIONS Assembly / Disassembly Instructions
				PART NO.

자재 명세

명칭		PE 부품 번호	8자리 부품 번호	
하우징 - 버스 바 하우 어셈블리 33272518	하우징	PE242429	33152669	
	버스 바	PE242426	33152670	
	버스 바	PE242427	33152672	
	버스 바	PE255013	33152673	
	버스 바	PE260273	33152674	
PLR		PE286899	33152676	
PLR		PE286900	33152677	
와이어 드레스 커버		PE242430	33152678	
와이어 드레스 커버		PE264537	33152679	

DATE	REVISION	AUTH	DR
25MY17	Initial Release - Frank Leritz	N/A	

캐비티 번호

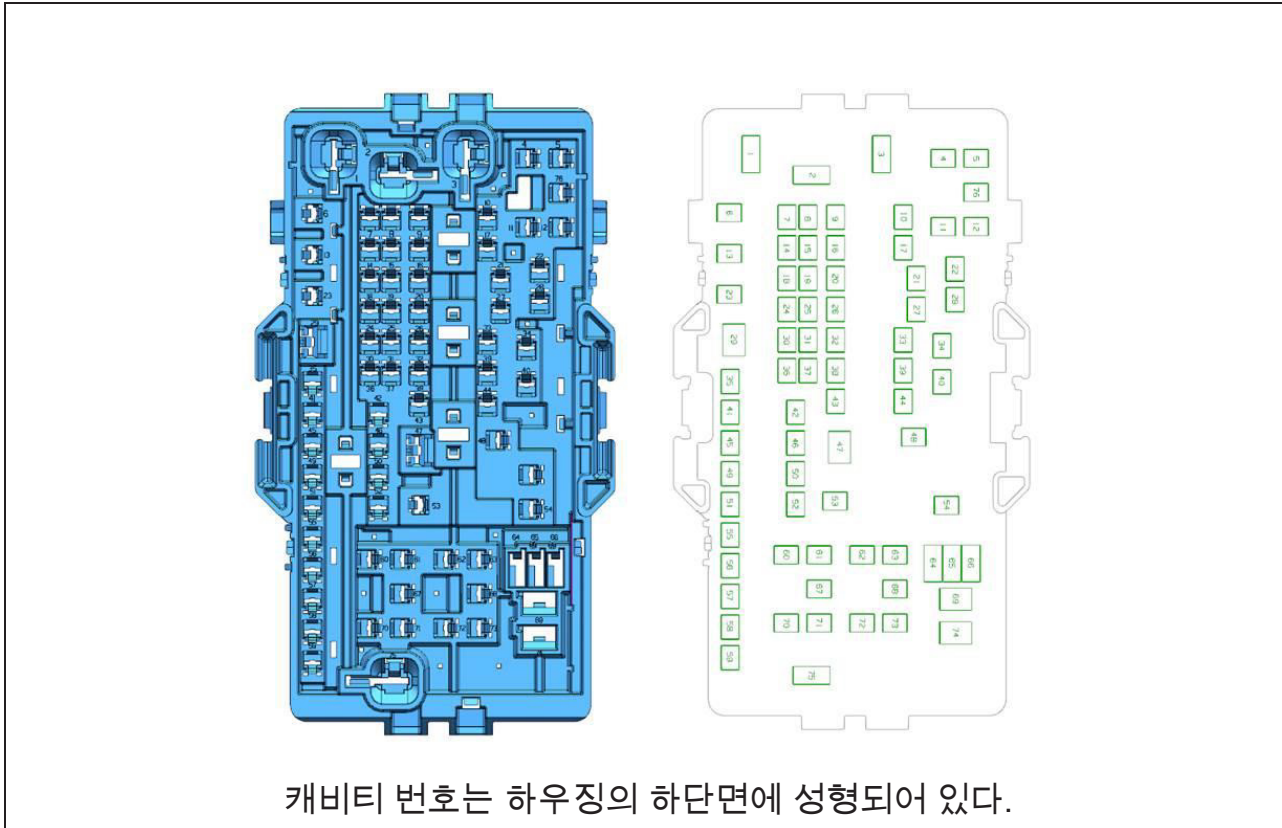

캐비티 번호는 하우징의 하단면에 성형되어 있다.

CAVITY INFORMATION			
CAVITY NAME	TERMINAL	DESCRIPTION	TYPICAL USE
1, 2, 3, 75	13979887	630 ASM F TERMINAL AG	BUSS BARS
4, 5, 7, 8, 9, 10, 11, 12, 14, 15, 16, 17, 18, 19, 20, 21, 22, 24, 25, 26, 27, 28, 30, 31, 32, 33, 34, 35, 36, 37, 38, 39, 40, 41, 42, 43, 44, 45, 46, 48, 49, 50, 51, 52, 54, 55, 56, 57, 58, 59, 60, 61, 62, 63, 67, 68, 70, 71, 72, 73, 76, 77	13849936	280 OCS F TERMINAL	RELAYS AND FUSES
6, 13, 23, 53	10725700	280 M TERMINAL	M-TYPE FUSE
29, 74	10725704	630 M TERMINAL	J-CASE FUSE
64, 65, 66, 69, 74	15344770	630 RELAY TERMINAL	LOGISTICS RELAY

캐비티 번호별 캐비티 타입 참조 차트

DATE	REVISION	AUTH	DR
25MY17	Initial Release - Frank Lertz	N/A	

TITLE
INSTALLATION INSTRUCTIONS Assembly / Disassembly Instructions
PART NO.
23322679
SHEET
60 OF 84

단자 삽입

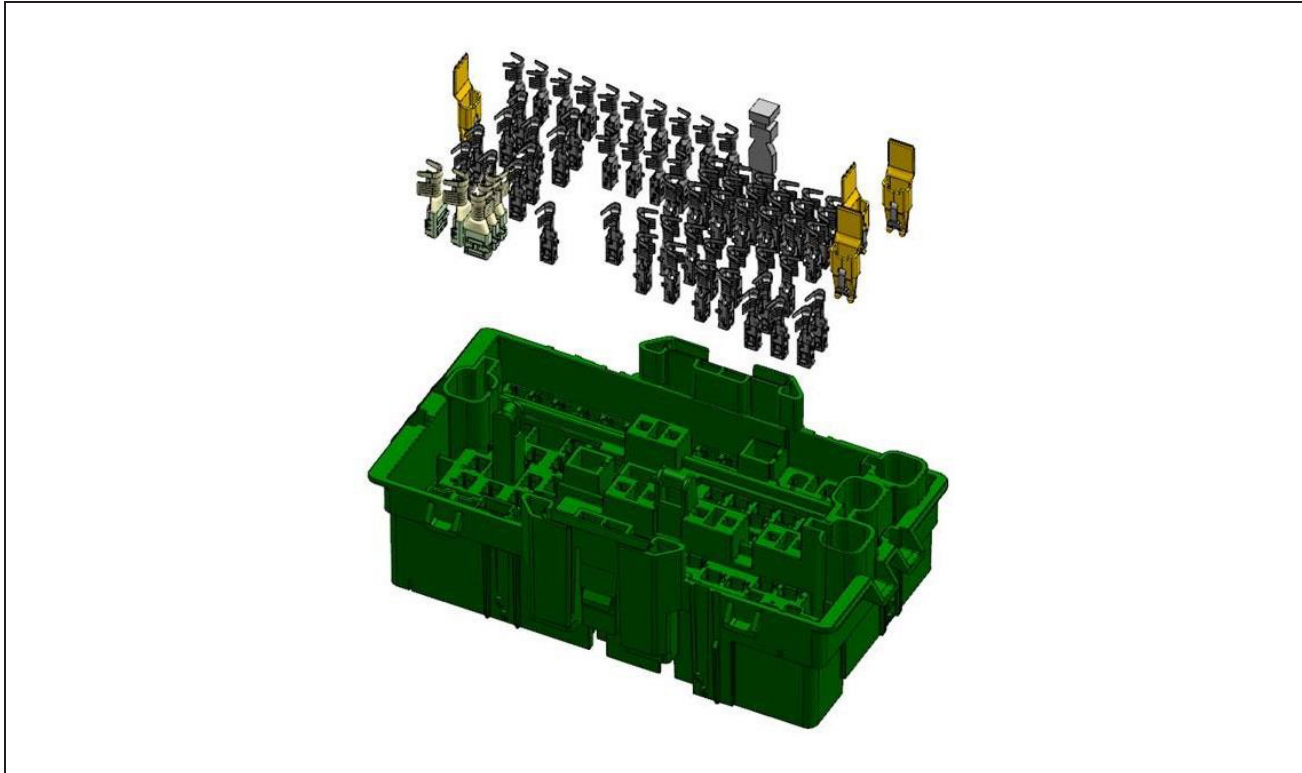

단자를 하단면을 이용해 해당 캐비티에 삽입한다. (이전 페이지의 차트 참조)

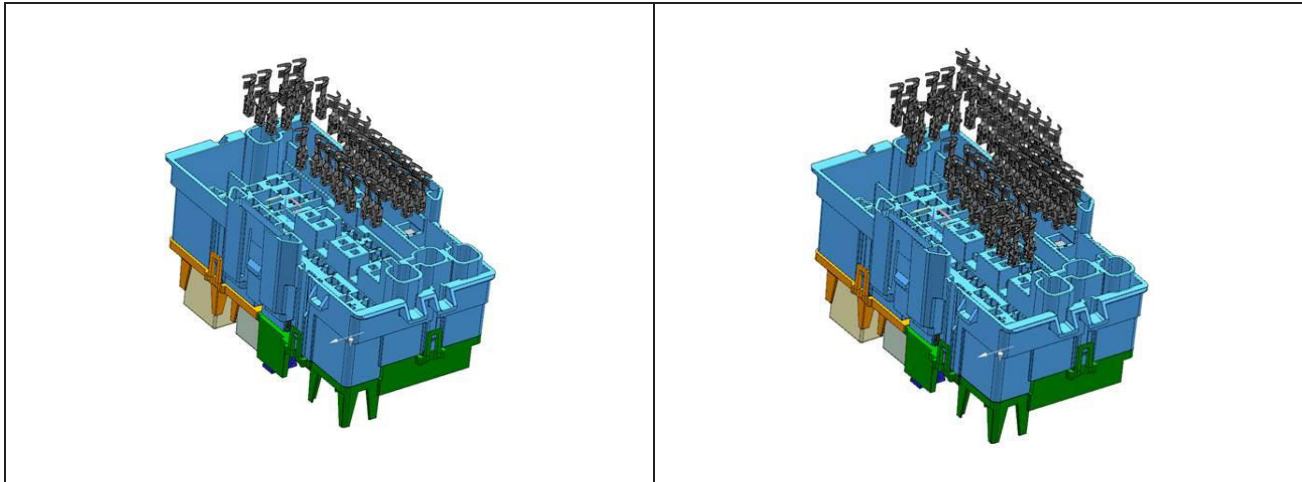

DATE	REVISION	AUTH	DR
25MY17	Initial Release - Frank Lertz	N/A	

TITLE	<b>INSTALLATION INSTRUCTIONS</b>		
	<b>Assembly / Disassembly Instructions</b>		
PART NO.	<b>23322679</b>	SHEET	<b>61</b> OF <b>84</b>

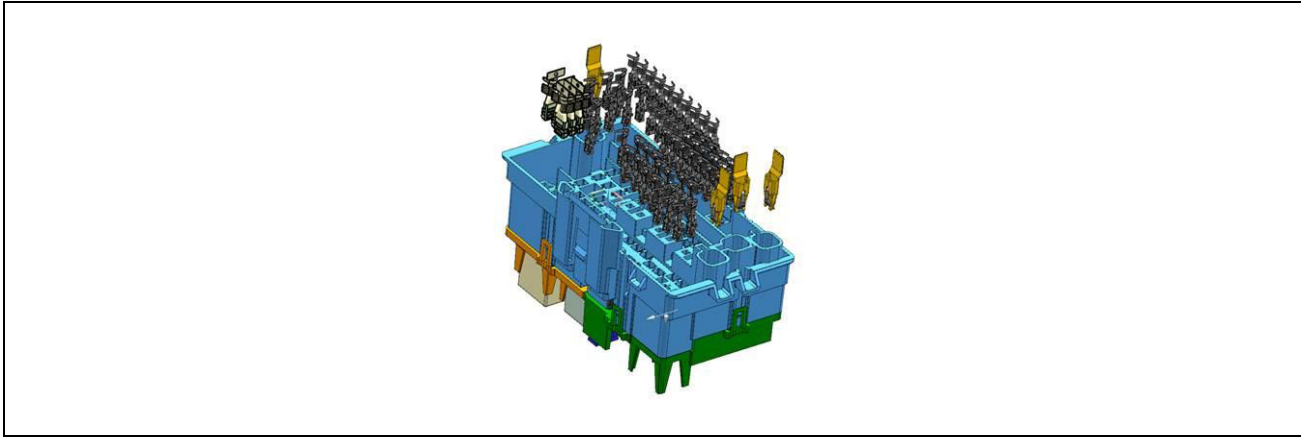

단자의 삽입은 하우징의 중앙에서 시작하여 변부 방향으로 실시한다.

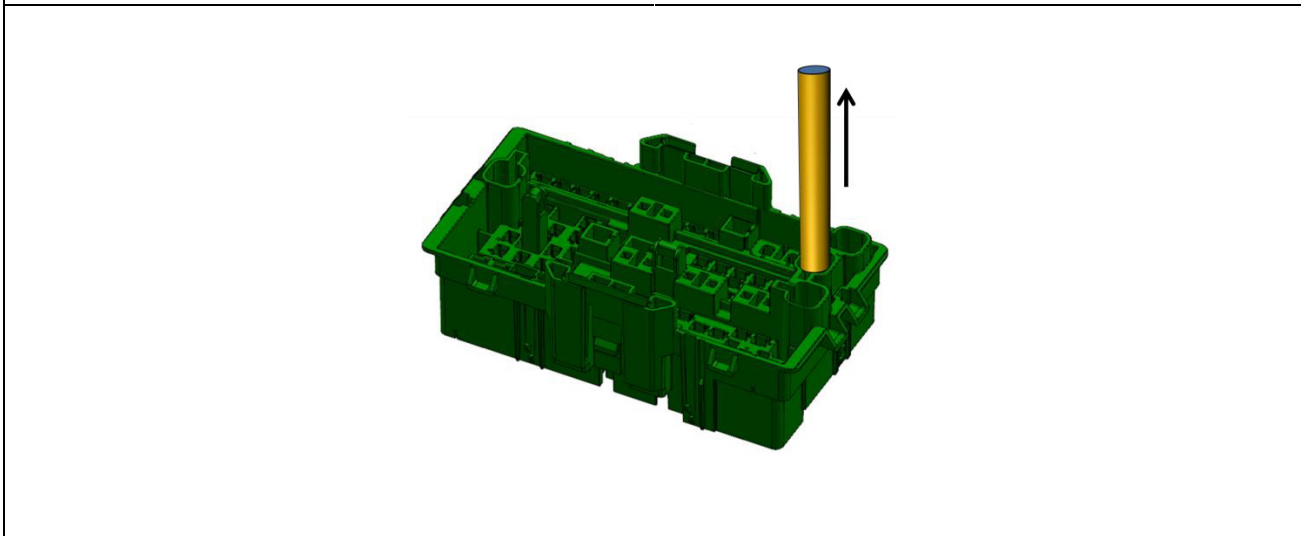

모든 삽입이 완료된 후 케이블을 부드럽게 당겨 잠금 시스템을 확인한다.

Assembly / Disassembly Instructions

IR 25MY17

PART NO.

23322679

SHEET

62 OF 84

ALL INFORMATION WITHIN ABOVE BORDER TO BE PRINTED EXACTLY AS SHOWN ON 8.5 x 11 WHITE 16 POUND NON-BOND RECYCLABLE PAPER. PRINT ON BOTH SIDES, EXCLUDING TEMPLATES. TO BE UNITIZED IN ACCORDANCE WITH GM SPECIFICATIONS.

DATE	REVISION	AUTH	DR
25MY17	Initial Release - Frank Lertz	N/A	

TITLE	PART NO.	SHEET
INSTALLATION INSTRUCTIONS Assembly / Disassembly Instructions	23322679	62 OF 84

PLR 배치

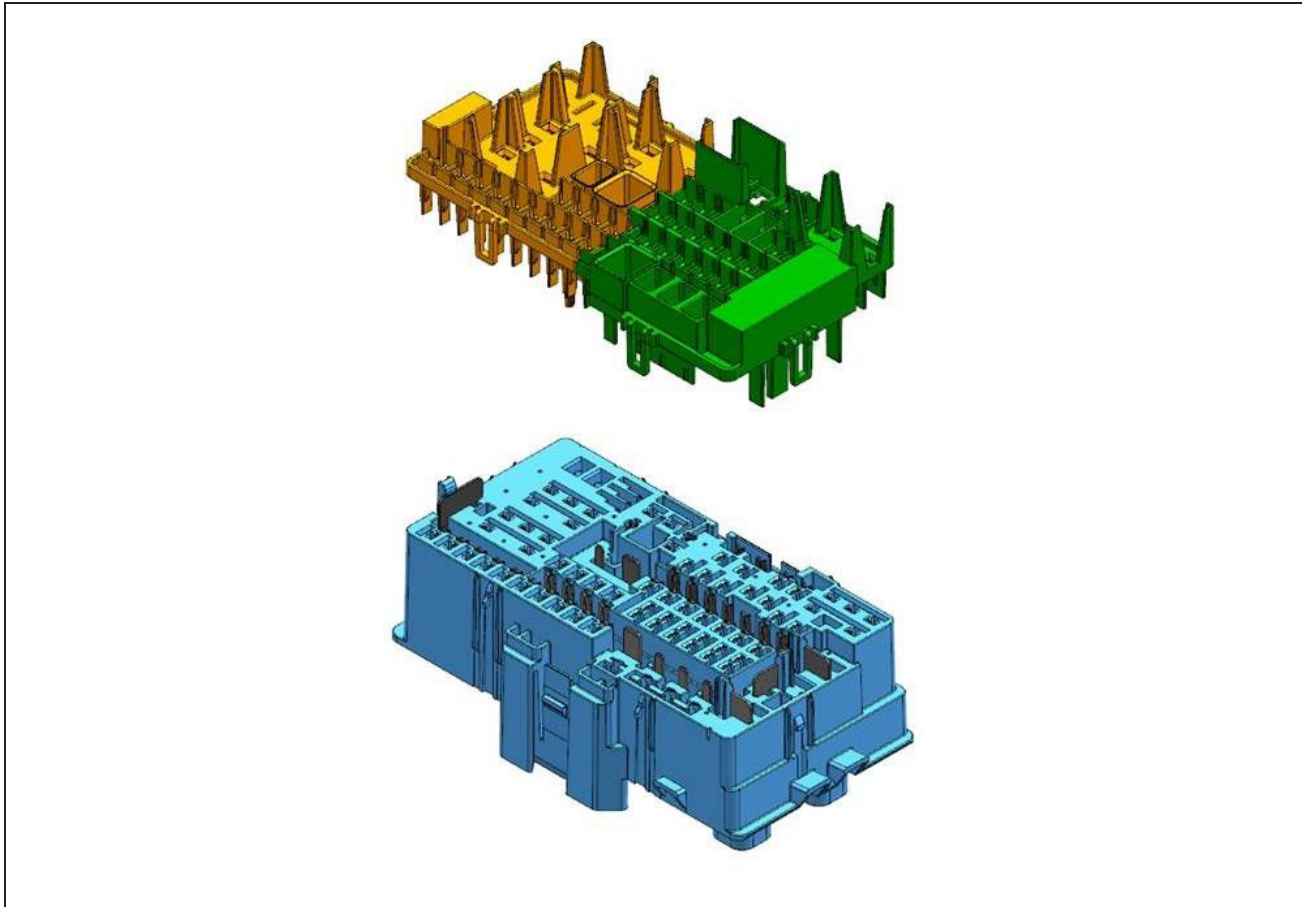

PLR(두 개)은 하나씩 조립할 수 있다. 조립 순서가 있는 것은 아니다.

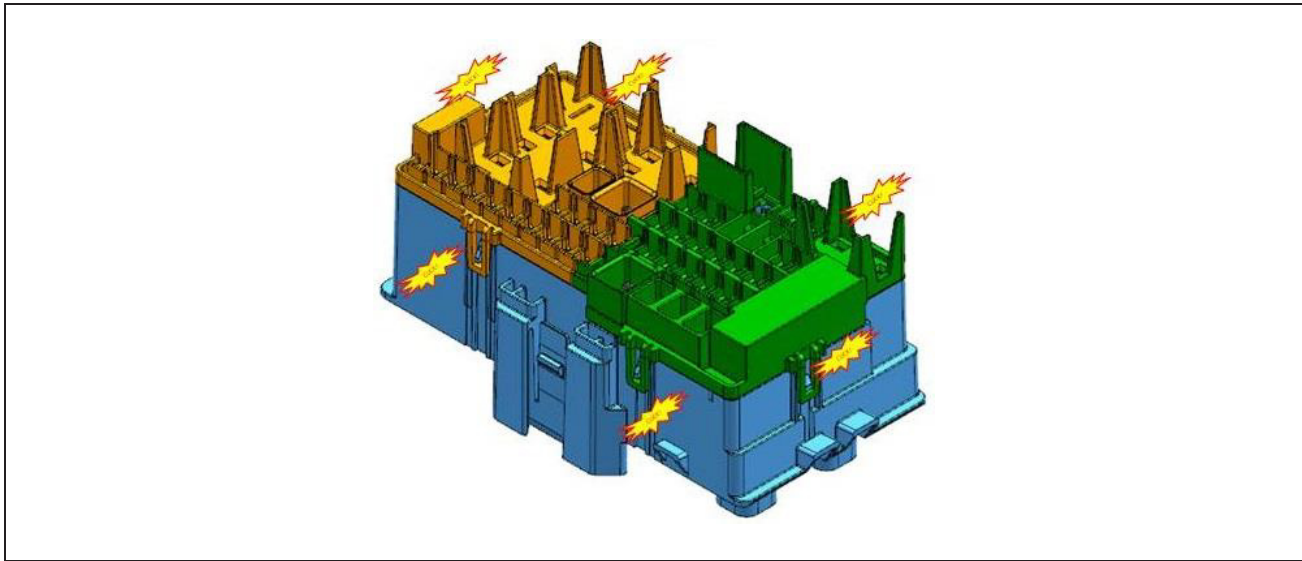

PLR은 체결음이 들릴 때까지 하우스 안쪽으로 완전히 민다.  
기계적 지원이 필요할 수 있다.

DATE	REVISION	AUTH	DR
25MY17	Initial Release - Frank Lertz	N/A	

TITLE
<b>INSTALLATION INSTRUCTIONS</b> <b>Assembly / Disassembly Instructions</b>
PART NO. <b>23322679</b> SHEET <b>63 OF 84</b>

장치 삽입

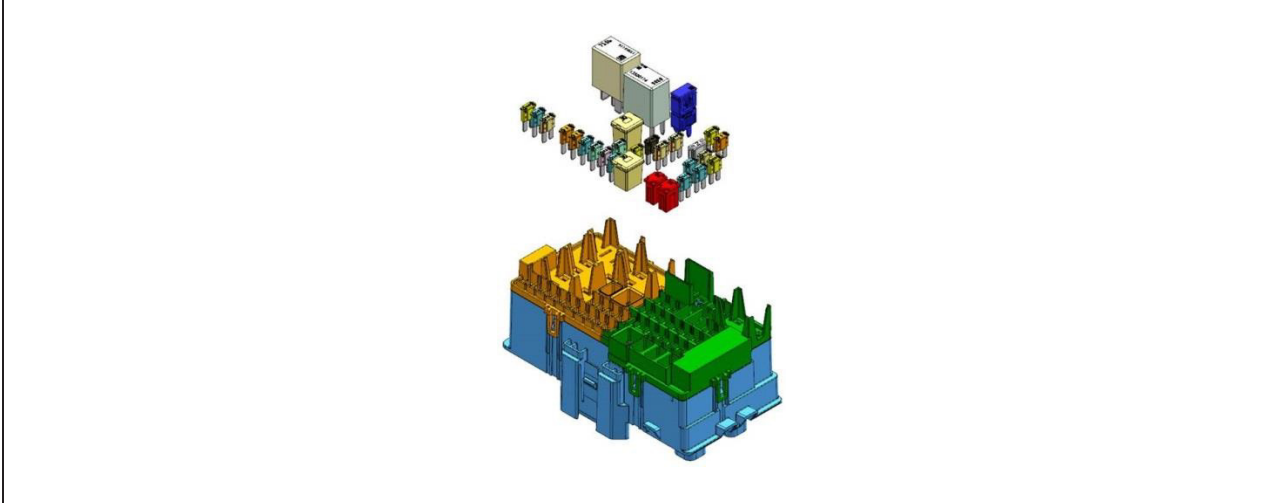

모델별로 필요한 대로 퓨즈 및 릴레이를 삽입한다.

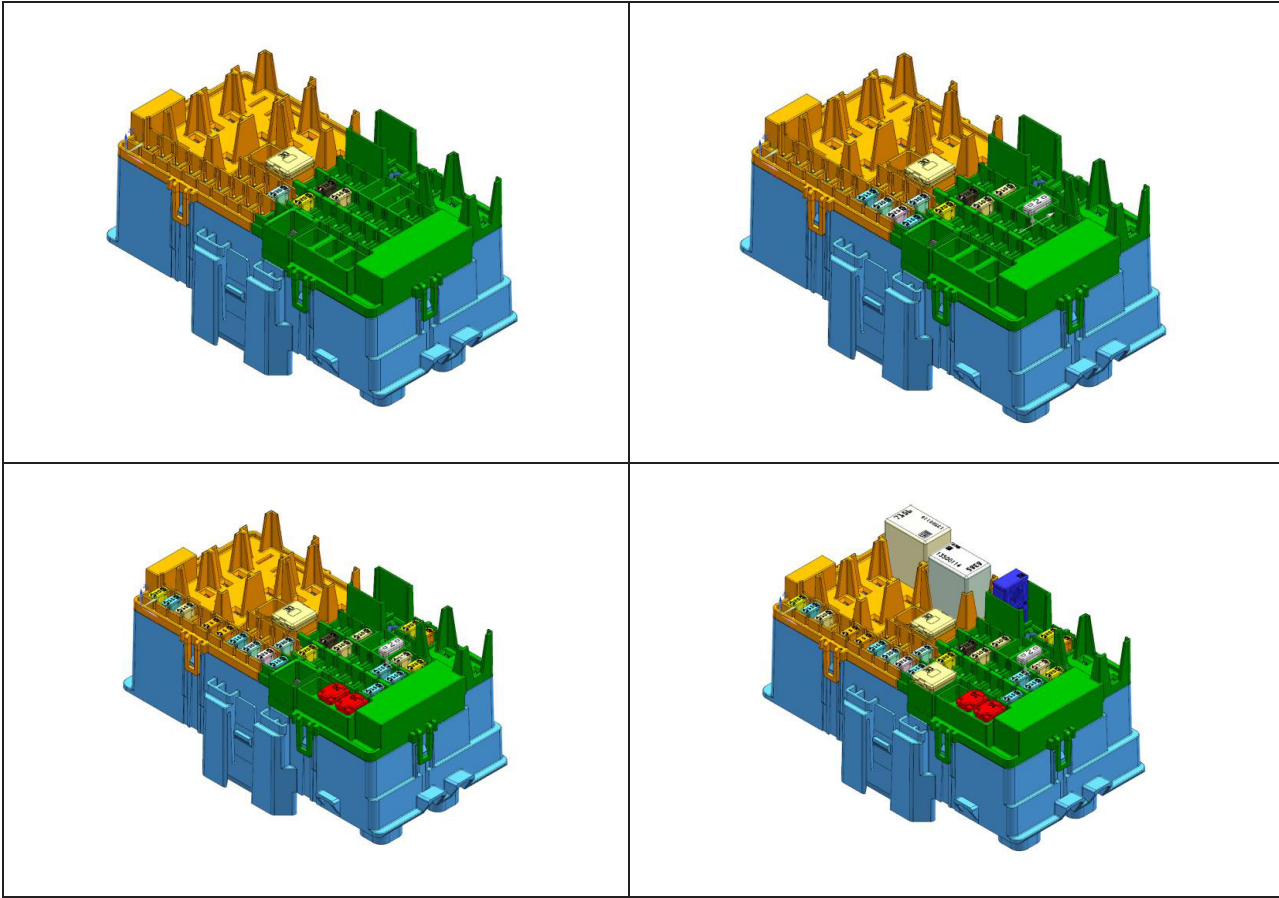

하우징의 중앙에 위치한 가장 낮은 높이의 장치를 먼저 삽입한다.  
더 높은 장치를 이용해 작업을 계속한다. 단자와 마찬가지로 하우징의 중앙에서 삽입을 시작한다.

DATE	REVISION	AUTH	DR
25MY17	Initial Release - Frank Lertz	N/A	

TITLE	INSTALLATION INSTRUCTIONS Assembly / Disassembly Instructions		
PART NO.	23322679	SHEET	64 OF 84

와이어 드레스 커버 배치

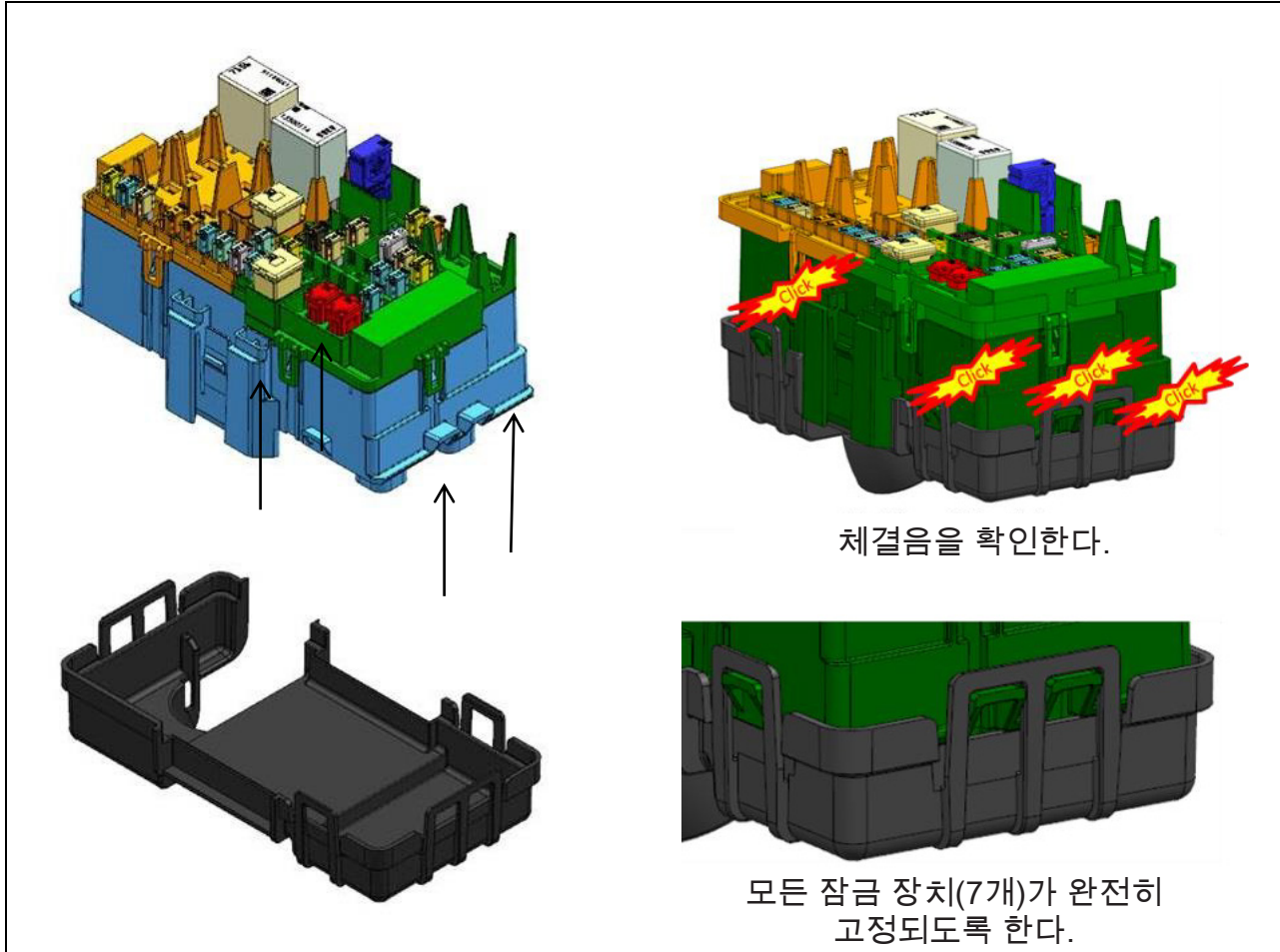

체결음을 확인한다.

모든 잠금 장치(7개)가 완전히 고정되도록 한다.

케이블을 필요한 하네스 배선 위치로 굽힌다.

모델별로 적절한 와이어 드레스 커버를 부착한 후 제공된 슬롯을 통해 와이어 타이를 삽입한다.

DATE	REVISION	AUTH	DR
25MY17	Initial Release - Frank Lertz	N/A	

TITLE	INSTALLATION INSTRUCTIONS Assembly / Disassembly Instructions		
PART NO.	23322679	SHEET	65 OF 84

일렉트릭얼 센터의 분해

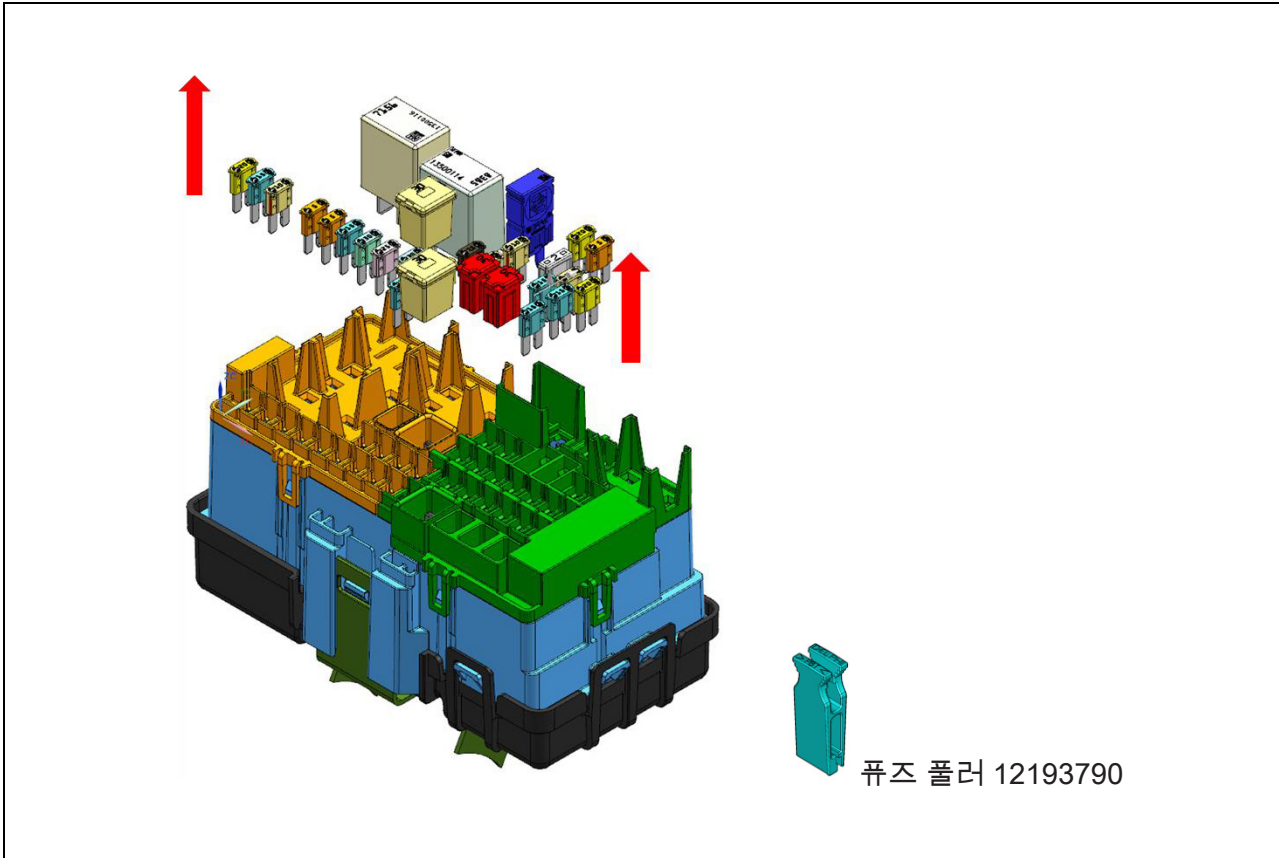

모든 장치를 제거한다. Delphi 퓨즈 풀러 12193790(권장)을 사용하여 제거한다.

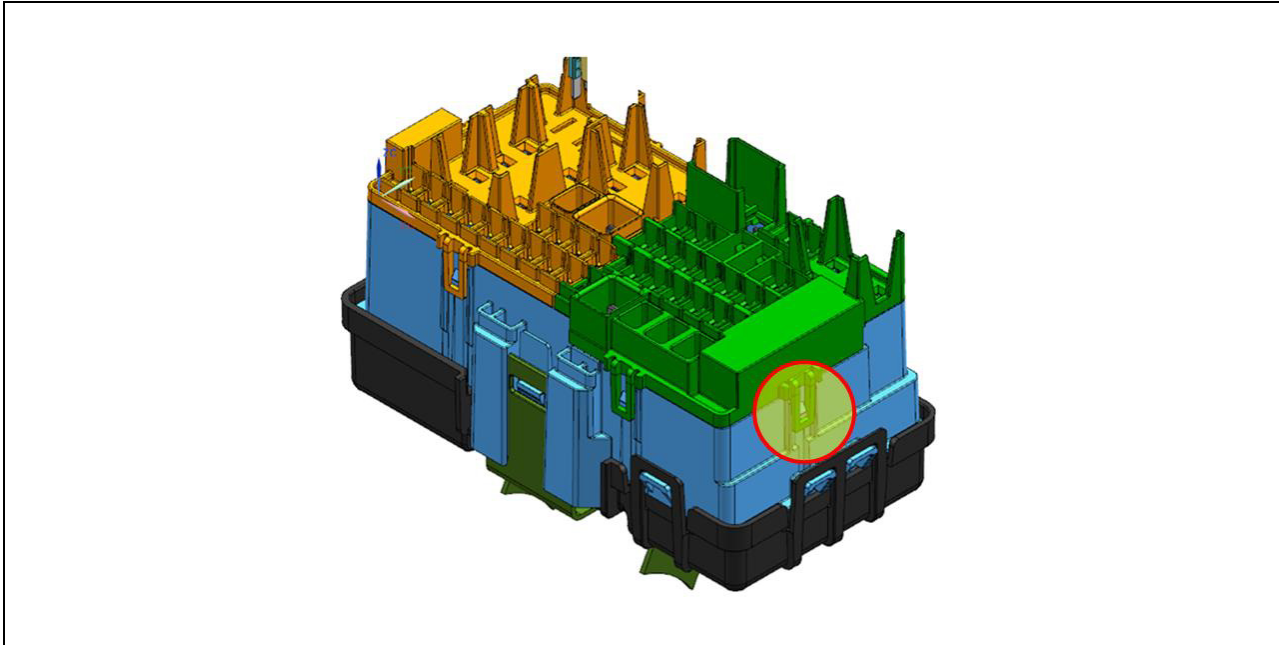

PLR 잠금 장치를 들어올린다.  
 잠금 장치는 작업 중 파손될 수 있다. 예비 부품을 이용할 수 있도록 한다.

DATE	REVISION	AUTH	DR	TITLE
25MY17	Initial Release - Frank Lertz	N/A		INSTALLATION INSTRUCTIONS Assembly / Disassembly Instructions

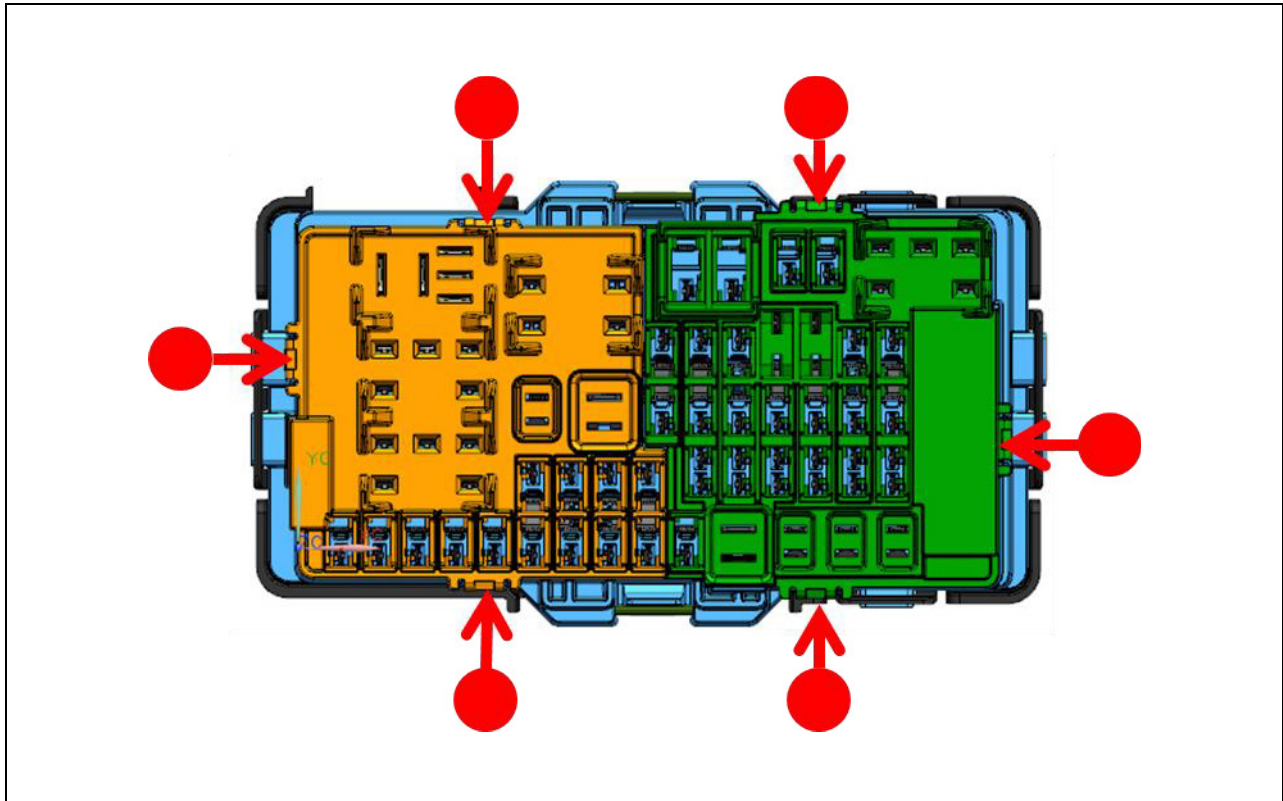

각 PLR에는 빨간색 원과 화살표가 표시하는 위치 또는 근처에 3개 이상의 잠금 장치가 있을 수 있다.

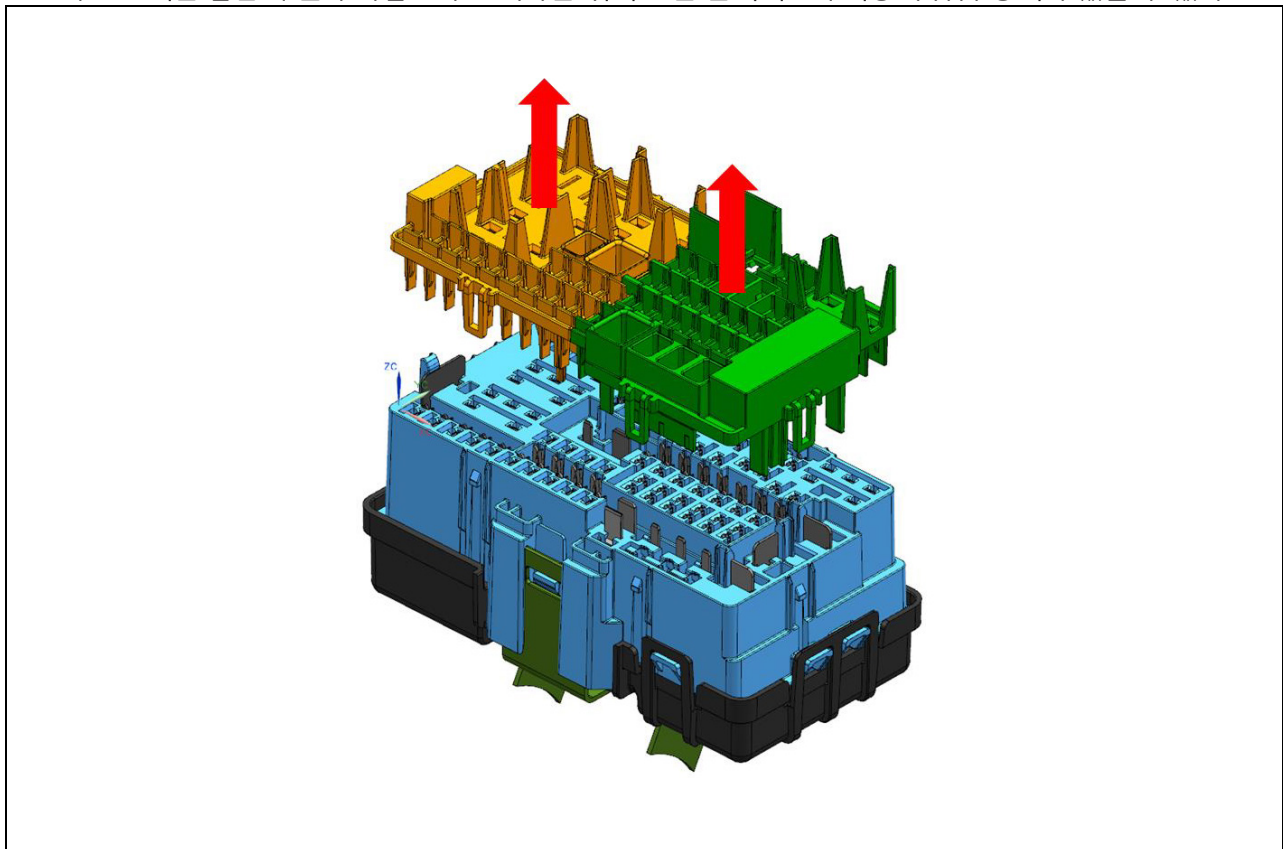

PLR을 제거한다.

Assembly / Disassembly Instructions

IR 25MY17

PART NO.

23322679

SHEET

67 OF 84

ALL INFORMATION WITHIN ABOVE BORDER TO BE PRINTED EXACTLY AS SHOWN ON 8.5 x 11 WHITE 16 POUND NON-BOND RECYCLABLE PAPER. PRINT ON BOTH SIDES, EXCLUDING TEMPLATES. TO BE UNITIZED IN ACCORDANCE WITH GM SPECIFICATIONS.

DATE	REVISION	AUTH	DR
25MY17	Initial Release - Frank Lertz	N/A	

TITLE
INSTALLATION INSTRUCTIONS Assembly / Disassembly Instructions
PART NO. 23322679
SHEET 67 OF 84

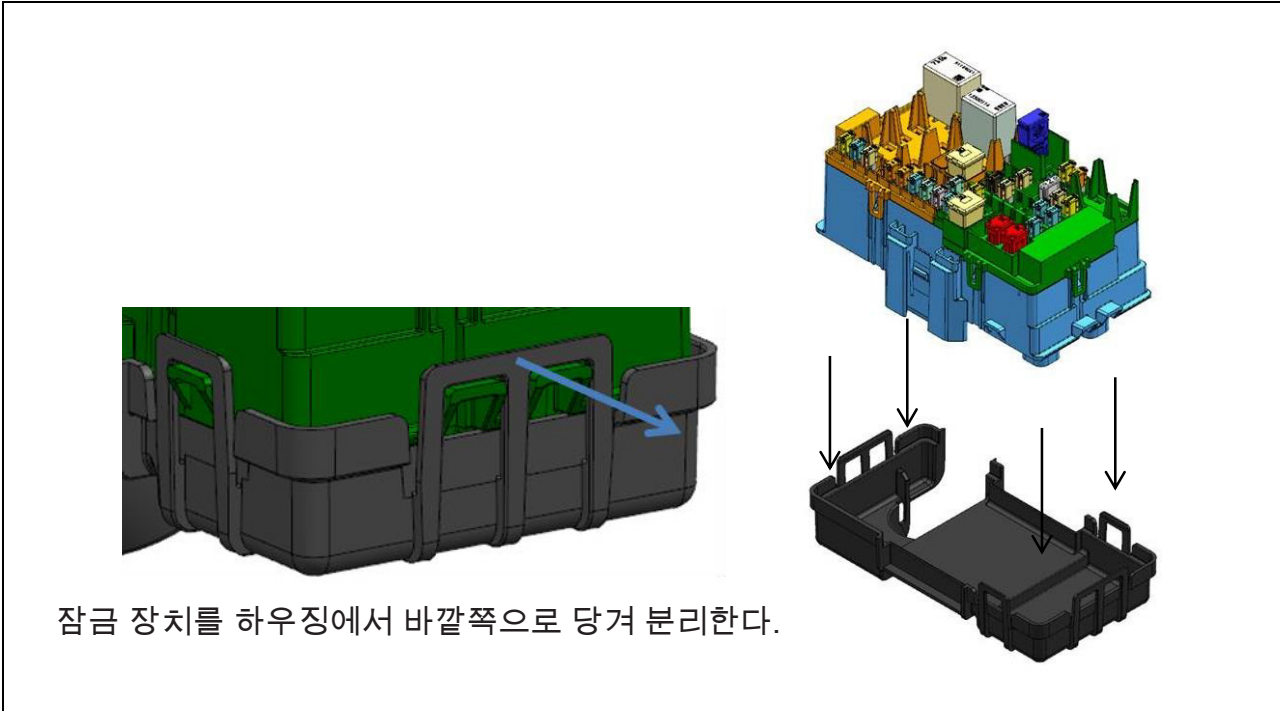

잠금 장치를 하우징에서 바깥쪽으로 당겨 분리한다.

와이어 드레스 커버를 제거한다.

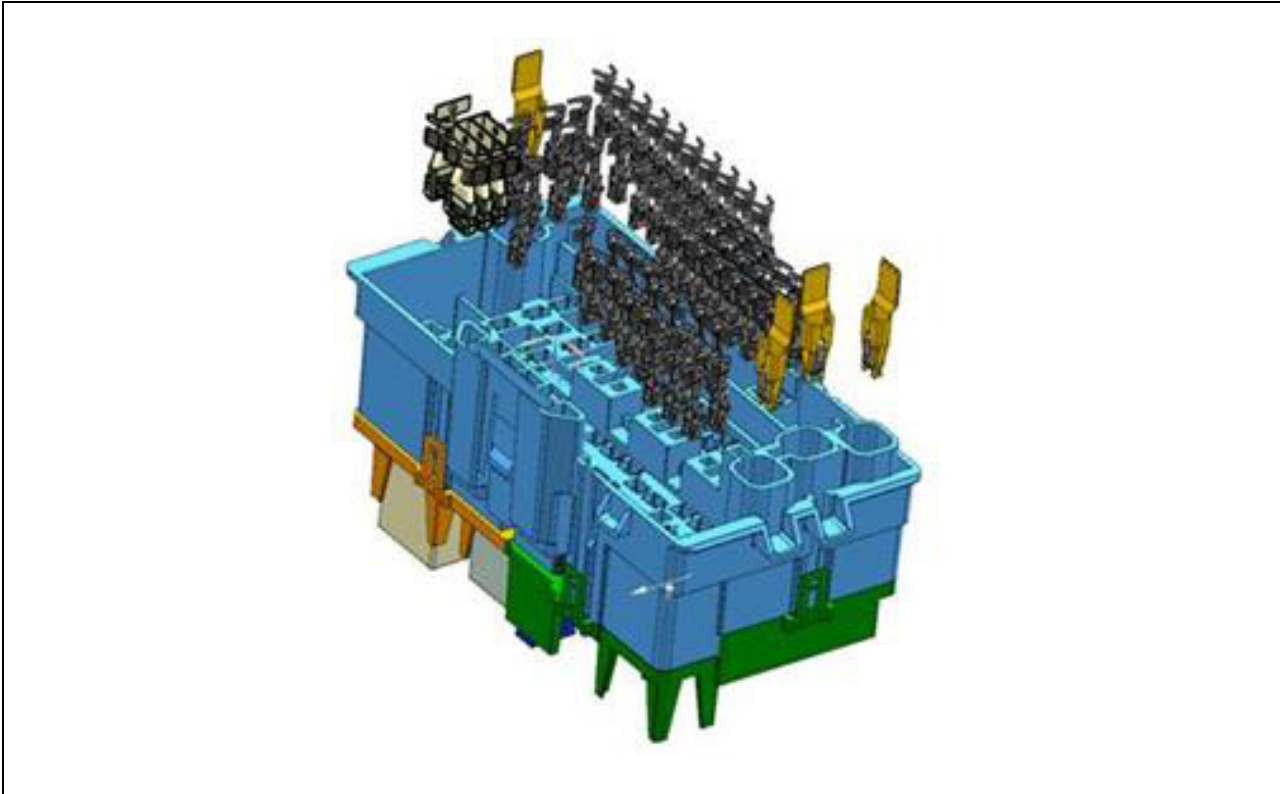

다음과 같은 방법을 사용하여 단자를 하나씩 제거한다.

ALL INFORMATION WITHIN ABOVE BORDER TO BE PRINTED EXACTLY AS SHOWN ON 8.5 x 11 WHITE 16 POUND NON-BOND RECYCLABLE PAPER. PRINT ON BOTH SIDES, EXCLUDING TEMPLATES. TO BE UNITIZED IN ACCORDANCE WITH GM SPECIFICATIONS.

DATE	REVISION	AUTH	DR
25MY17	Initial Release - Frank Lertz	N/A	

<b>INSTALLATION INSTRUCTIONS</b> <b>Assembly / Disassembly Instructions</b>	
PART NO.	<b>23322679</b> SHEET <b>68</b> OF <b>84</b>

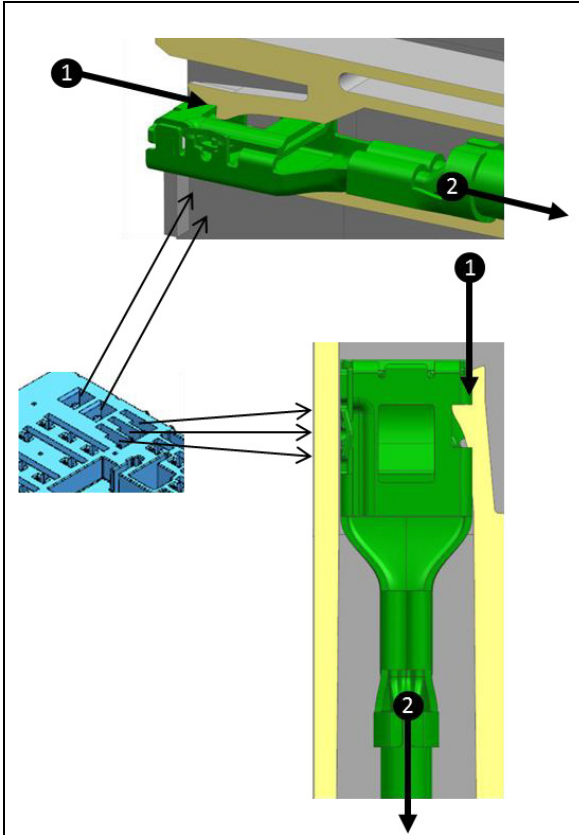

630F 단자(로지스틱 릴레이).

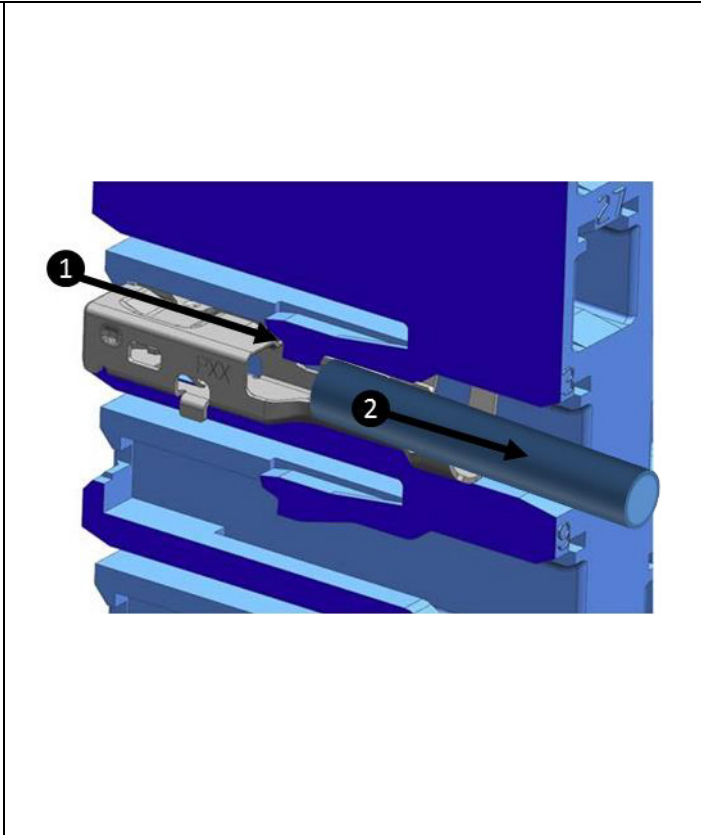

280F 단자(퓨즈, 회로차단기 및 릴레이).

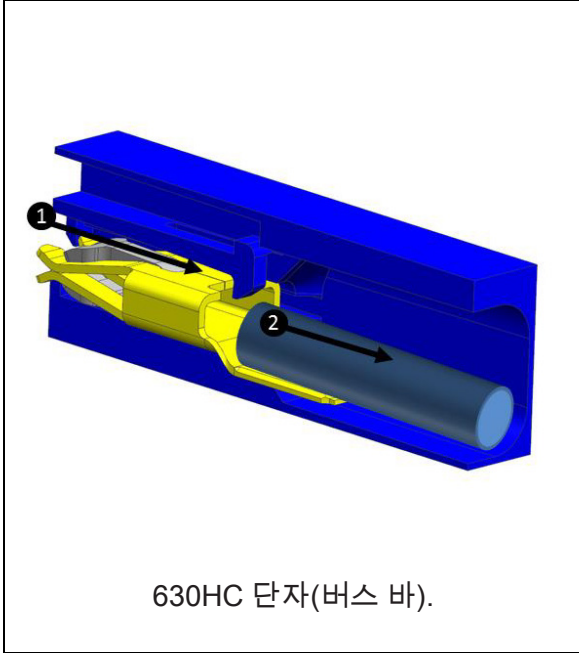

630HC 단자(버스 바).

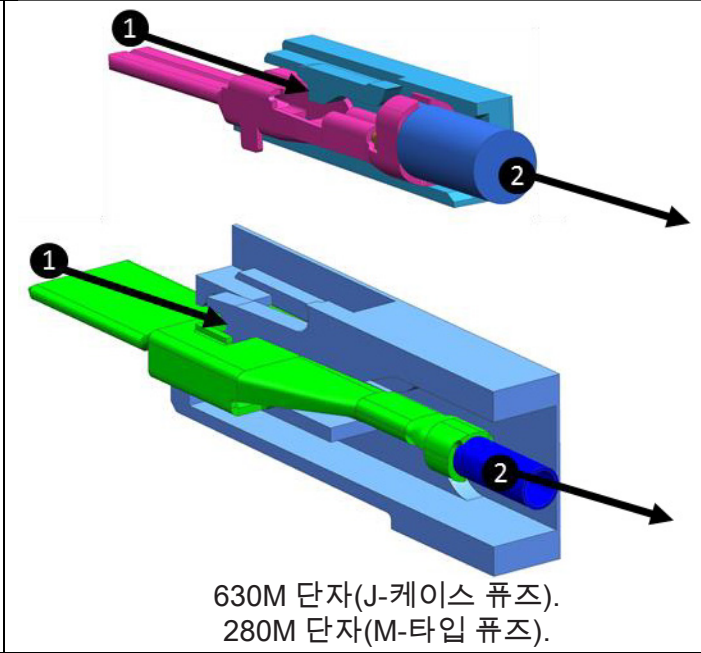

630M 단자(J-케이스 퓨즈).  
280M 단자(M-타입 퓨즈).

작업 순서

1. 플라스틱 하우징에서 유연 잠금 장치를 찾아 들어 올린다.
2. 케이블을 당겨 단자를 뽑는다.

Assembly / Disassembly Instructions

IR 25MY17

PART NO.

23322679

SHEET

69 OF 84

ALL INFORMATION WITHIN ABOVE BORDER TO BE PRINTED EXACTLY AS SHOWN ON 8.5 x 11 WHITE 16 POUND NON-BOND RECYCLABLE PAPER. PRINT ON BOTH SIDES, EXCLUDING TEMPLATES. TO BE UNITIZED IN ACCORDANCE WITH GM SPECIFICATIONS.

DATE	REVISION	AUTH	DR
25MY17	Initial Release - Frank Lertiz	N/A	

TITLE	PART NO.	SHEET
INSTALLATION INSTRUCTIONS Assembly / Disassembly Instructions	23322679	69 OF 84

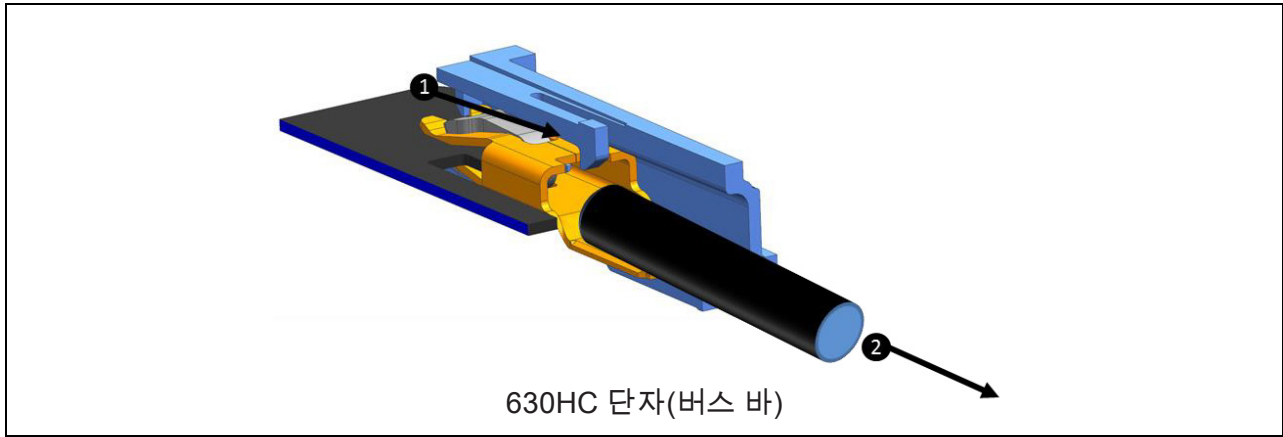

630HC 단자(버스 바)

작업 순서

1. 플라스틱 하우징에서 유연 잠금 장치를 찾아 들어 올린다.
2. 케이블을 당겨 단자를 뽑는다.

권장 수리 공구

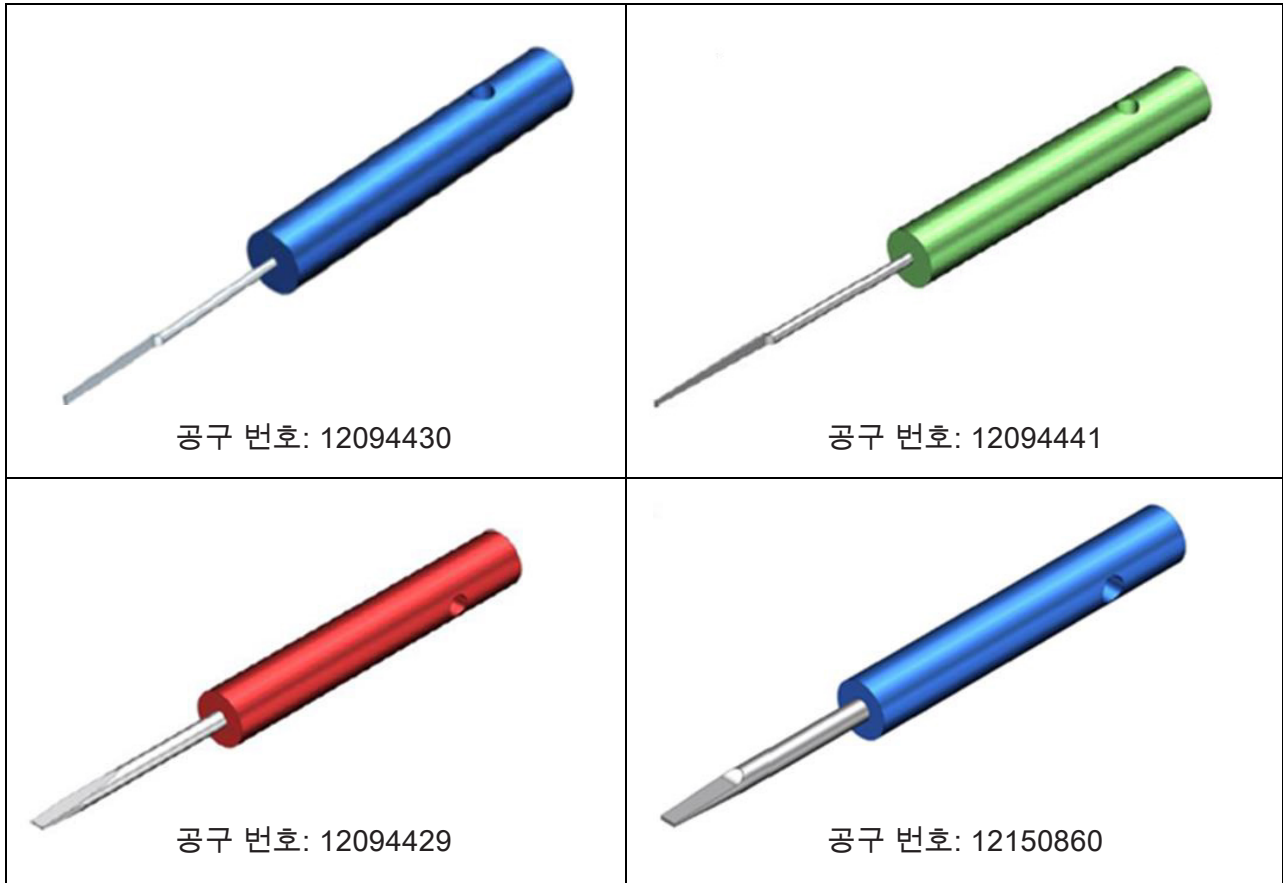

공구 번호: 12094430

공구 번호: 12094441

공구 번호: 12094429

공구 번호: 12150860

DATE	REVISION	AUTH	DR
25MY17	Initial Release - Frank Lertz	N/A	

TITLE	PART NO.	SHEET	OF
INSTALLATION INSTRUCTIONS Assembly / Disassembly Instructions	23322679	70	84

**Montage-/Demontageanleitung**

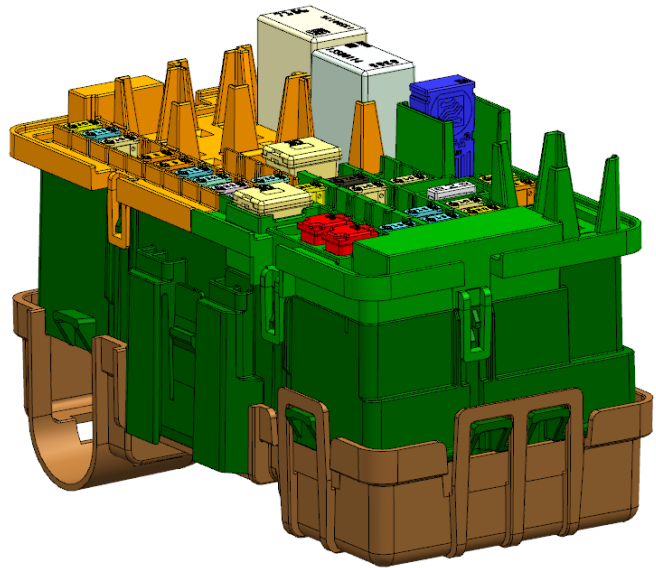
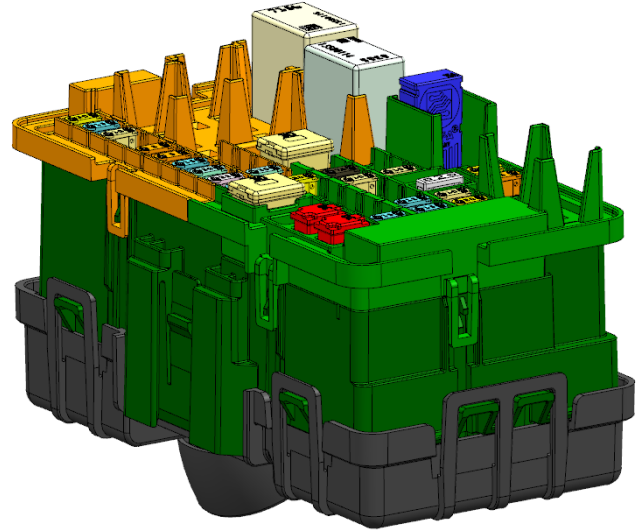

**Assembly / Disassembly Instructions**

**IR 25MY17**

PART NO.

**23322679**

SHEET **71** OF **84**

ALL INFORMATION WITHIN ABOVE BORDER TO BE PRINTED EXACTLY AS SHOWN ON 8.5 x 11 WHITE 16 POUND NON-BOND RECYCLABLE PAPER. PRINT ON BOTH SIDES, EXCLUDING TEMPLATES. TO BE UNITIZED IN ACCORDANCE WITH GM SPECIFICATIONS.

DATE	REVISION	AUTH	DR
25MY17	Initial Release - Frank Lertz	N/A	

TITLE	<b>INSTALLATION INSTRUCTIONS Assembly / Disassembly Instructions</b>		
PART NO.	<b>23322679</b>	SHEET	<b>71</b> OF <b>84</b>

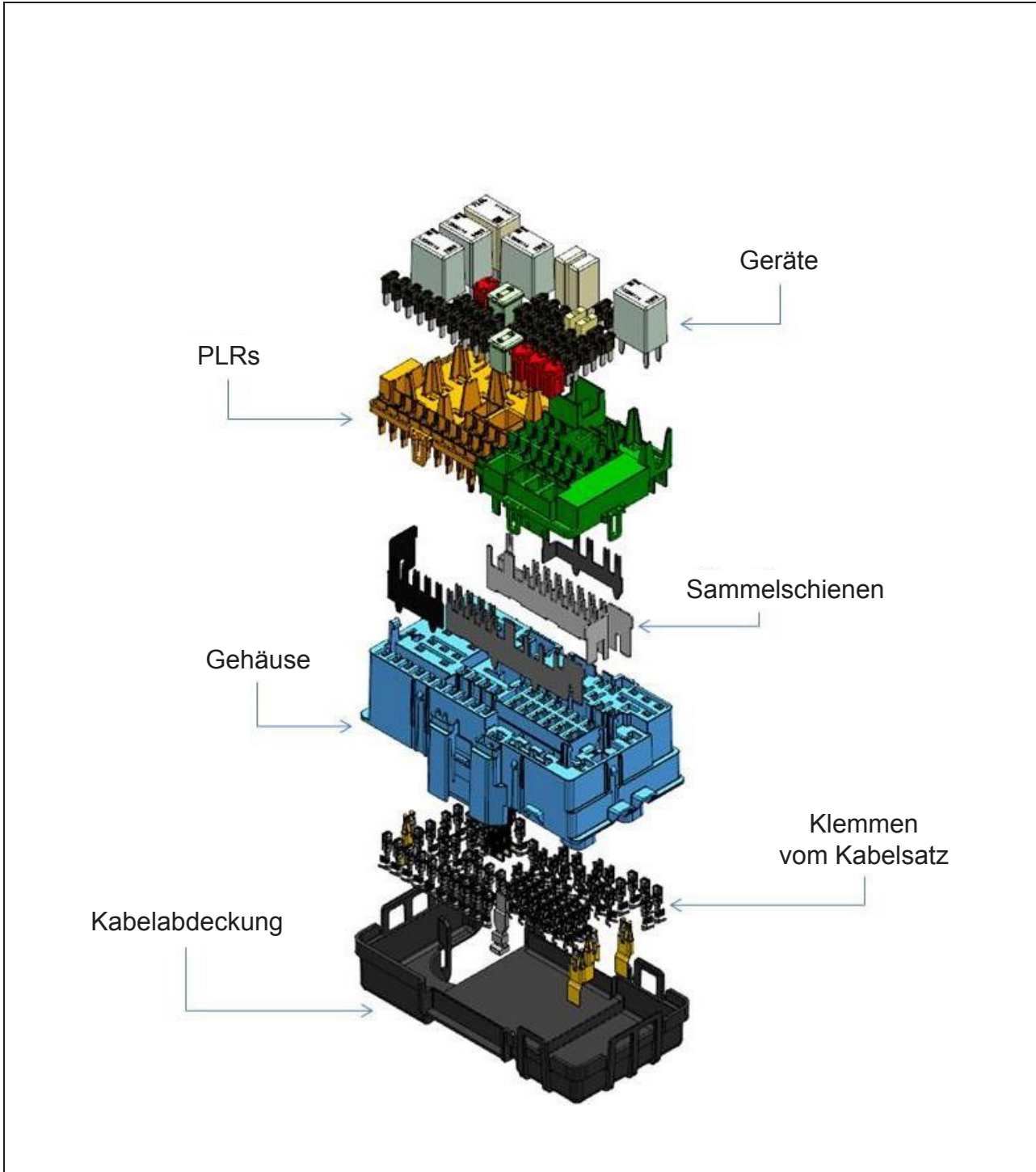

**Explosionsdarstellung**



DATE	REVISION	AUTH	DR
25MY17	Initial Release - Frank Lertz	N/A	

TITLE
<b>INSTALLATION INSTRUCTIONS Assembly / Disassembly Instructions</b>
PART NO. <b>23322679</b> SHEET <b>72 OF 84</b>

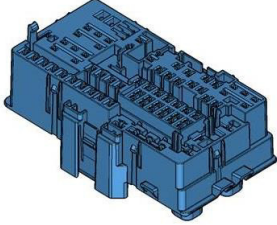
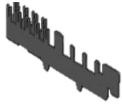
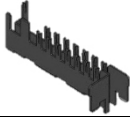
Stückliste

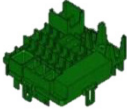
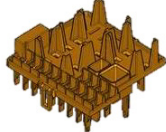
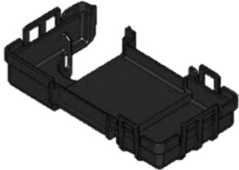
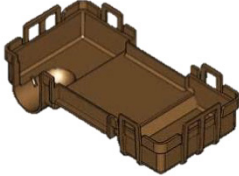
Bezeichnung		PE-Teilenummer	8-stellige Teilenummer	
Gehäuse - Sammelschiene Unterbaugruppe 33272518	Gehäuse	PE242429	33152669	
	Sammel- schiene	PE242426	33152670	
	Sammel- schiene	PE242427	33152672	
	Sammel- schiene	PE255013	33152673	
	Sammel- schiene	PE260273	33152674	
PLR		PE286899	33152676	
PLR		PE286900	33152677	
Kabelabdeckung		PE242430	33152678	
Kabelabdeckung		PE264537	33152679	

Assembly / Disassembly Instructions

IR 25MY17

PART NO.

**23322679**

SHEET

**73** OF **84**

ALL INFORMATION WITHIN ABOVE BORDER TO BE PRINTED EXACTLY AS SHOWN ON 8.5 x 11 WHITE 16 POUND NON-BOND RECYCLABLE PAPER. PRINT ON BOTH SIDES, EXCLUDING TEMPLATES. TO BE UNITIZED IN ACCORDANCE WITH GM SPECIFICATIONS.

DATE	REVISION	AUTH	DR
25MY17	Initial Release - Frank Lertz	N/A	

TITLE

**INSTALLATION INSTRUCTIONS  
Assembly / Disassembly Instructions**

PART NO.

**23322679**

SHEET

**73** OF **84**

### Nummerierung der Kontaktkammern

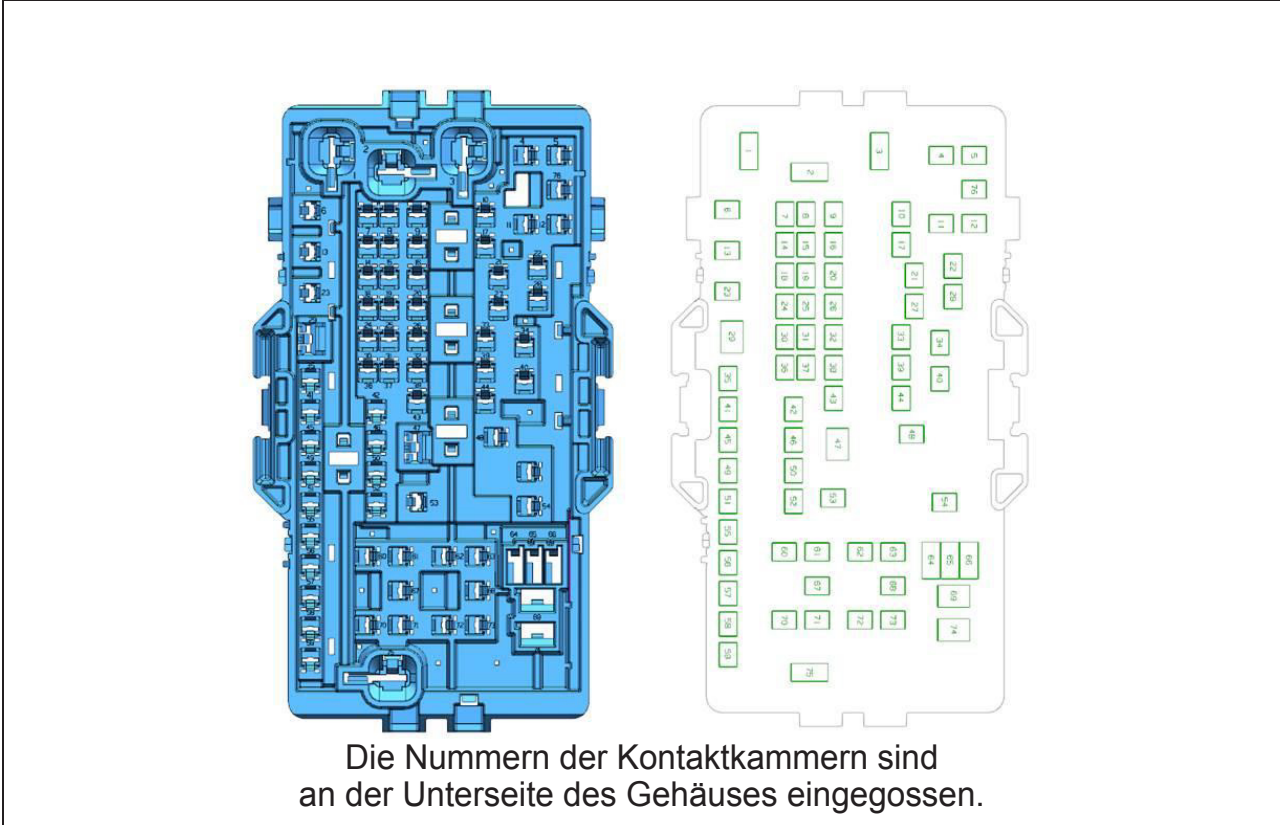

Die Nummern der Kontaktkammern sind an der Unterseite des Gehäuses eingegossen.

CAVITY INFORMATION			
CAVITY NAME	TERMINAL	DESCRIPTION	TYPICAL USE
1, 2, 3, 75	13979887	630 ASM F TERMINAL AG	BUSS BARS
4, 5, 7, 8, 9, 10, 11, 12, 14, 15, 16, 17, 18, 19, 20, 21, 22, 24, 25, 26, 27, 28, 30, 31, 32, 33, 34, 35, 36, 37, 38, 39, 40, 41, 42, 43, 44, 45, 46, 48, 49, 50, 51, 52, 54, 55, 56, 57, 58, 59, 60, 61, 62, 63, 67, 68, 70, 71, 72, 73, 76, 77	13849936	280 OCS F TERMINAL	RELAYS AND FUSES
6, 13, 23, 53	10725700	280 M TERMINAL	M-TYPE FUSE
29, 74	10725704	630 M TERMINAL	J-CASE FUSE
64, 65, 66, 69, 74	15344770	630 RELAY TERMINAL	LOGISTICS RELAY

Referenztable für Kammertyp pro Kammernummer

DATE	REVISION	AUTH	DR
25MY17	Initial Release - Frank Lertz	N/A	

TITLE	
<b>INSTALLATION INSTRUCTIONS Assembly / Disassembly Instructions</b>	
PART NO. <b>23322679</b> SHEET <b>74</b> OF <b>84</b>	

### Klemmenbestückung

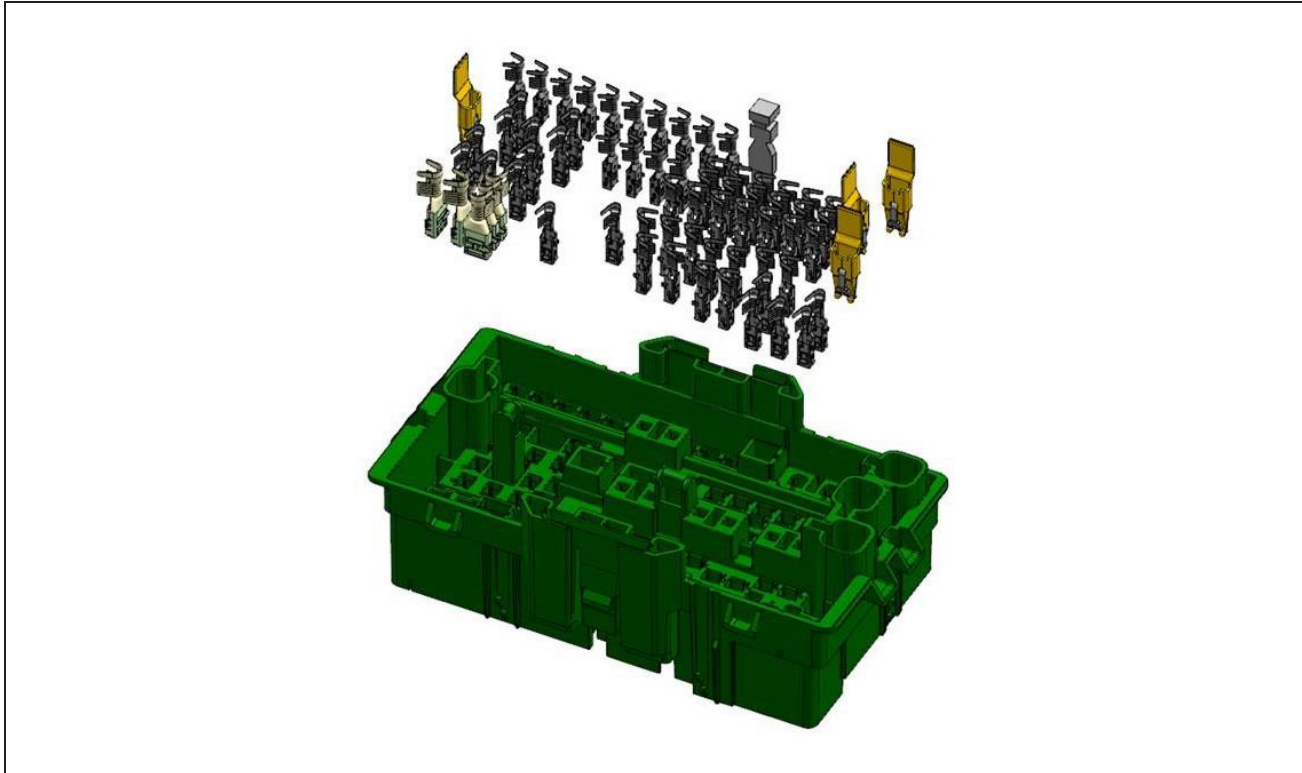

Sie setzen die Klemmen von der Unterseite in die jeweilige Kammer ein.  
(Siehe Tabelle auf der vorigen Seite.)

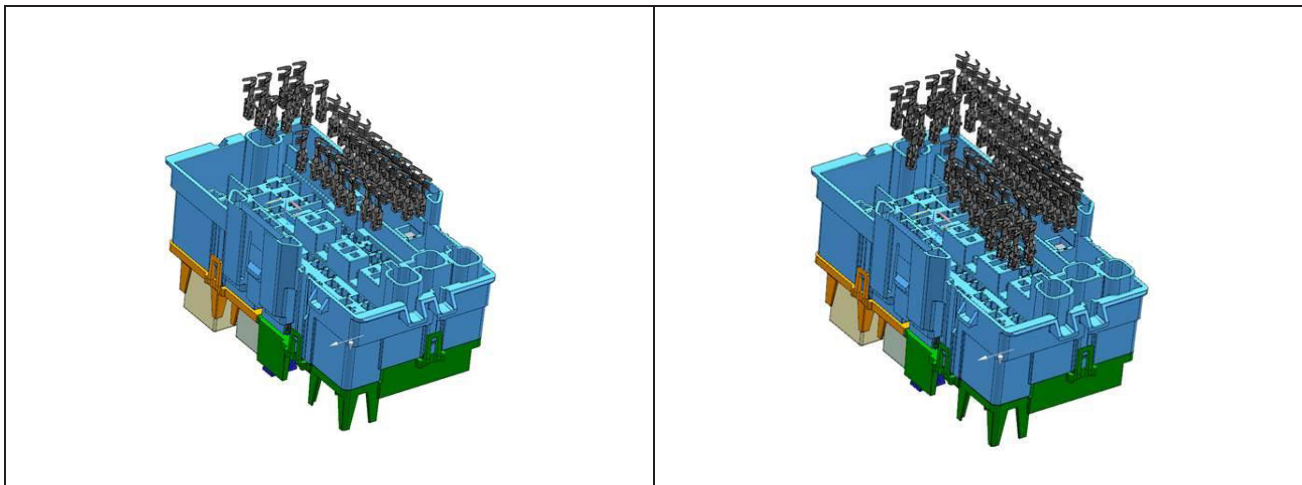

DATE	REVISION	AUTH	DR
25MY17	Initial Release - Frank Lertz	N/A	

TITLE	<b>INSTALLATION INSTRUCTIONS Assembly / Disassembly Instructions</b>		
PART NO.	<b>23322679</b>	SHEET	<b>75 OF 84</b>

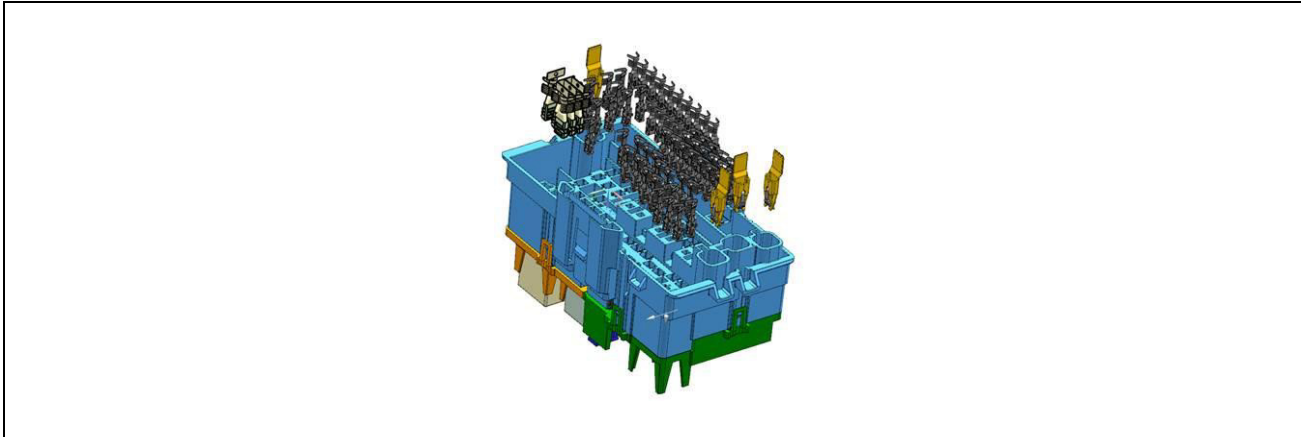

Beginnen Sie damit in der Gehäusemitte und arbeiten Sie sich zu den Rändern vor.

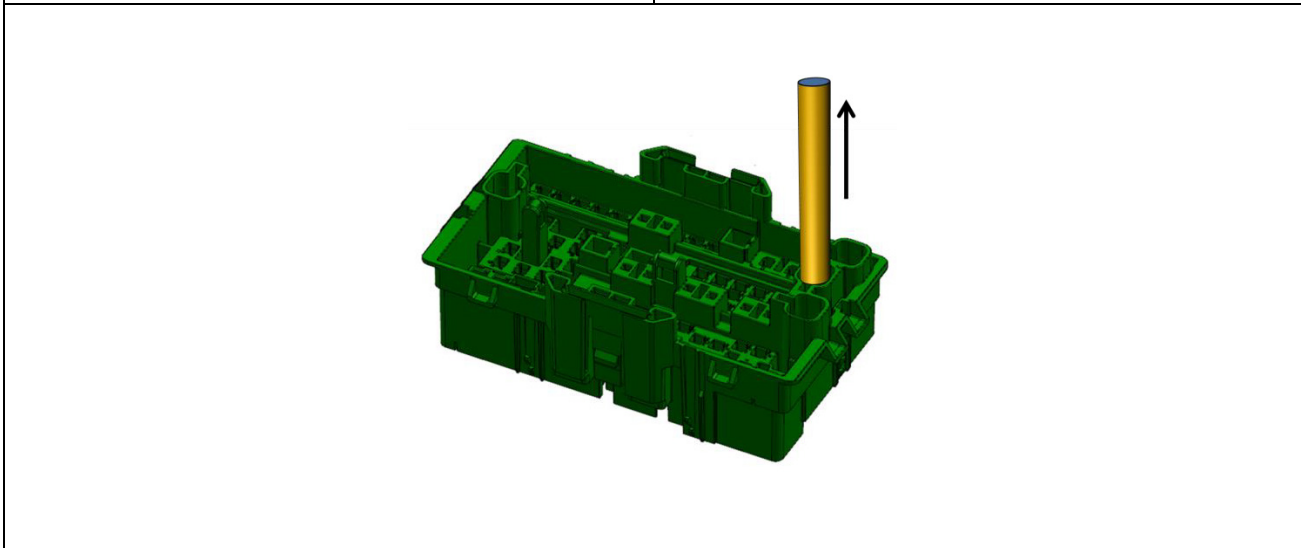

Nach jedem Einsetzen ziehen Sie vorsichtig am Kabel, um das Verriegelungssystem zu prüfen.

DATE	REVISION	AUTH	DR
25MY17	Initial Release - Frank Lertz	N/A	

TITLE	<b>INSTALLATION INSTRUCTIONS Assembly / Disassembly Instructions</b>		
PART NO.	<b>23322679</b>	SHEET	<b>76 OF 84</b>

**Positionieren der PLRs**

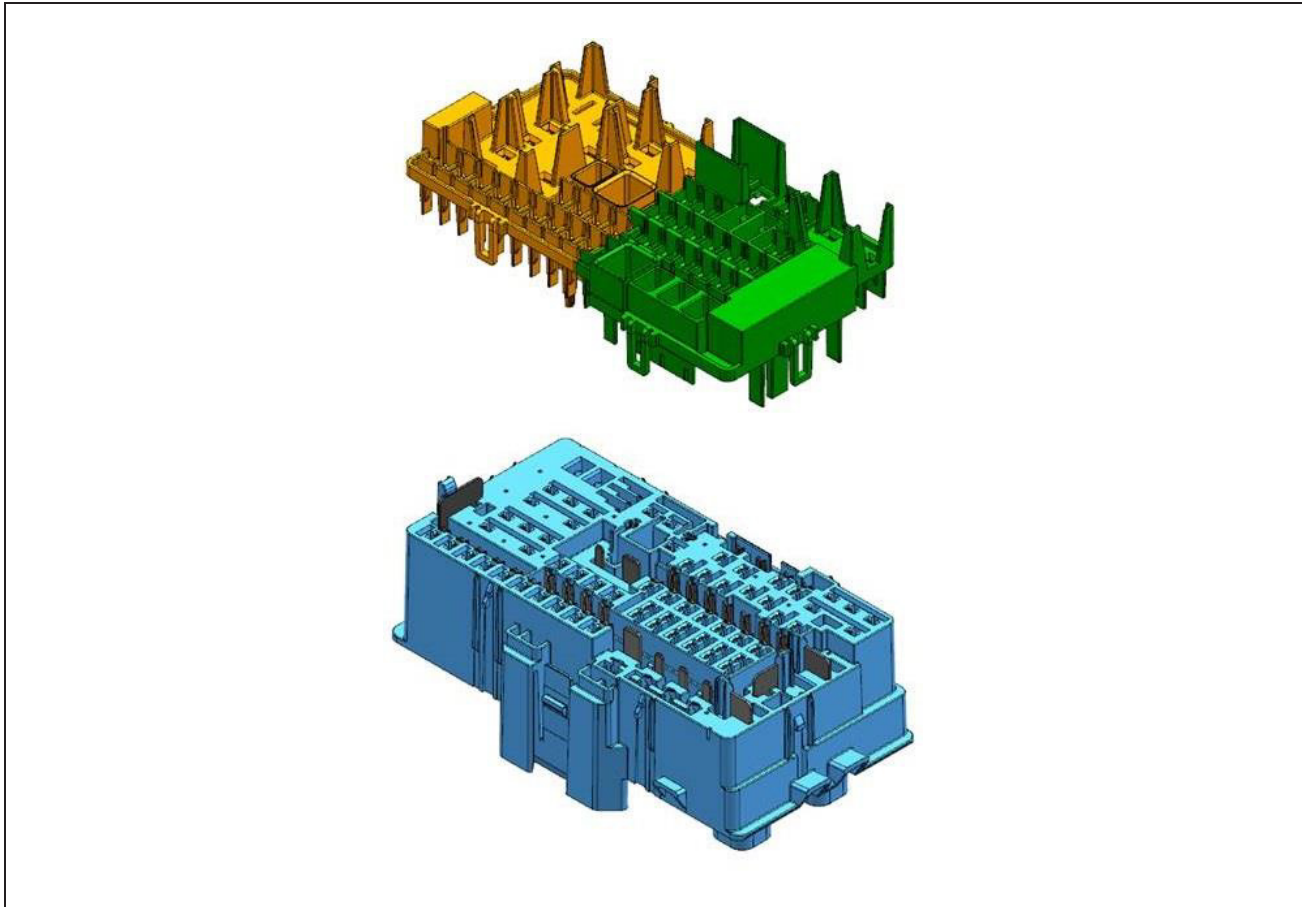

Die PLRs (zwei) können nacheinander montiert werden. Die Reihenfolge der Montage spielt keine Rolle.

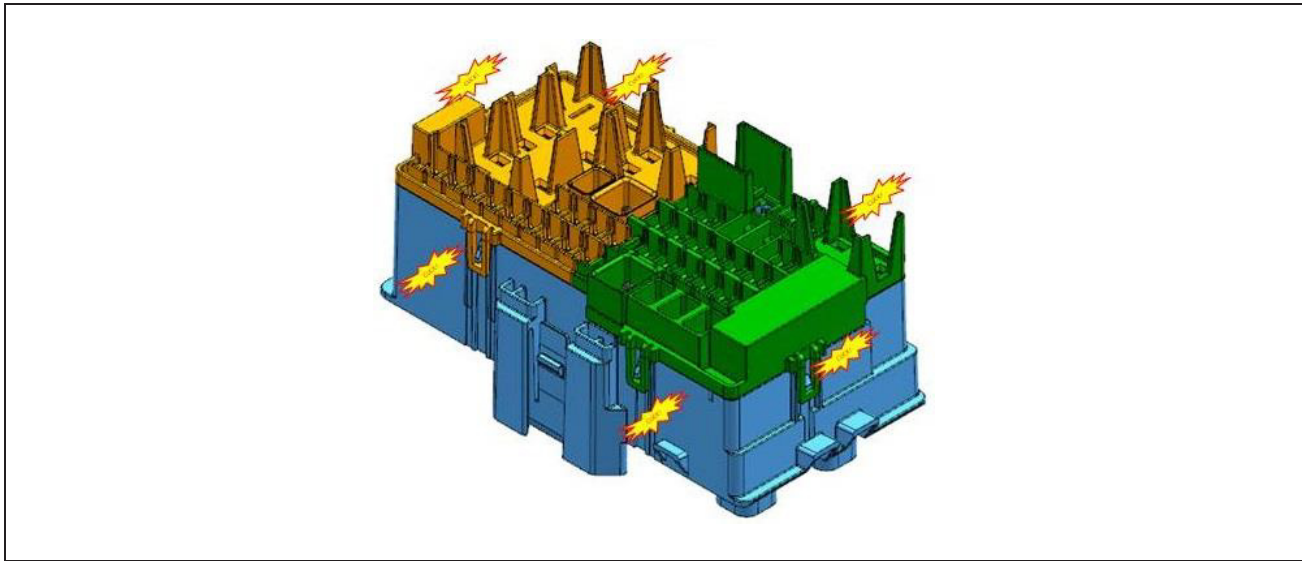

Drücken Sie die PLRs bis zum Anschlag in das Gehäuse, bis ein Klicken zu hören ist. Es kann mechanische Unterstützung erforderlich sein.

DATE	REVISION	AUTH	DR
25MY17	Initial Release - Frank Lertz	N/A	

TITLE	<b>INSTALLATION INSTRUCTIONS</b>		
	<b>Assembly / Disassembly Instructions</b>		
PART NO.	<b>23322679</b>	SHEET	<b>77</b> OF <b>84</b>

### Einsetzen von Geräten

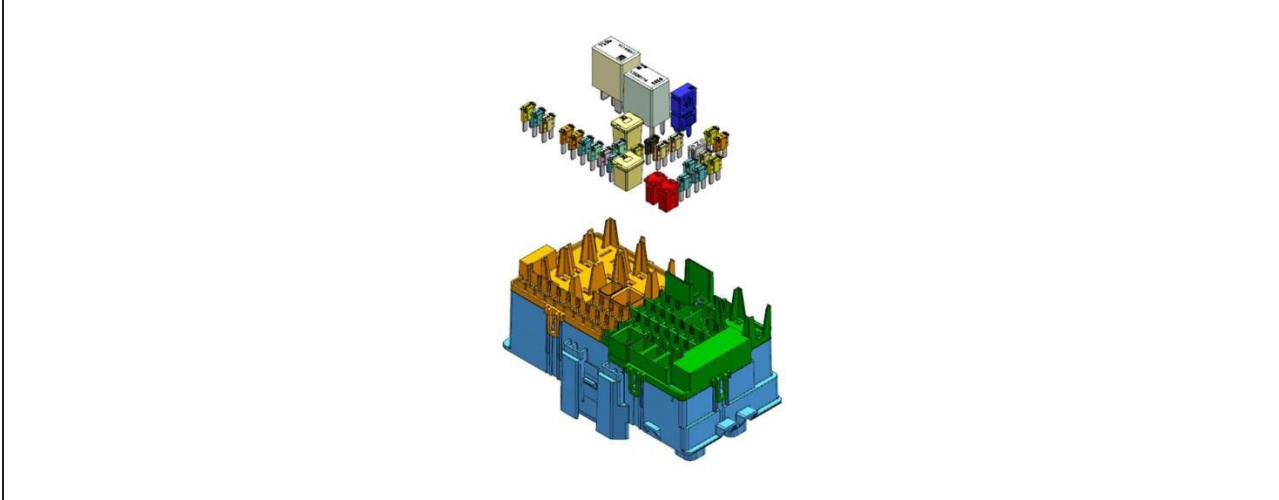

Setzen Sie die Sicherungen und Relais ein, die das jeweilige Modell erfordert.

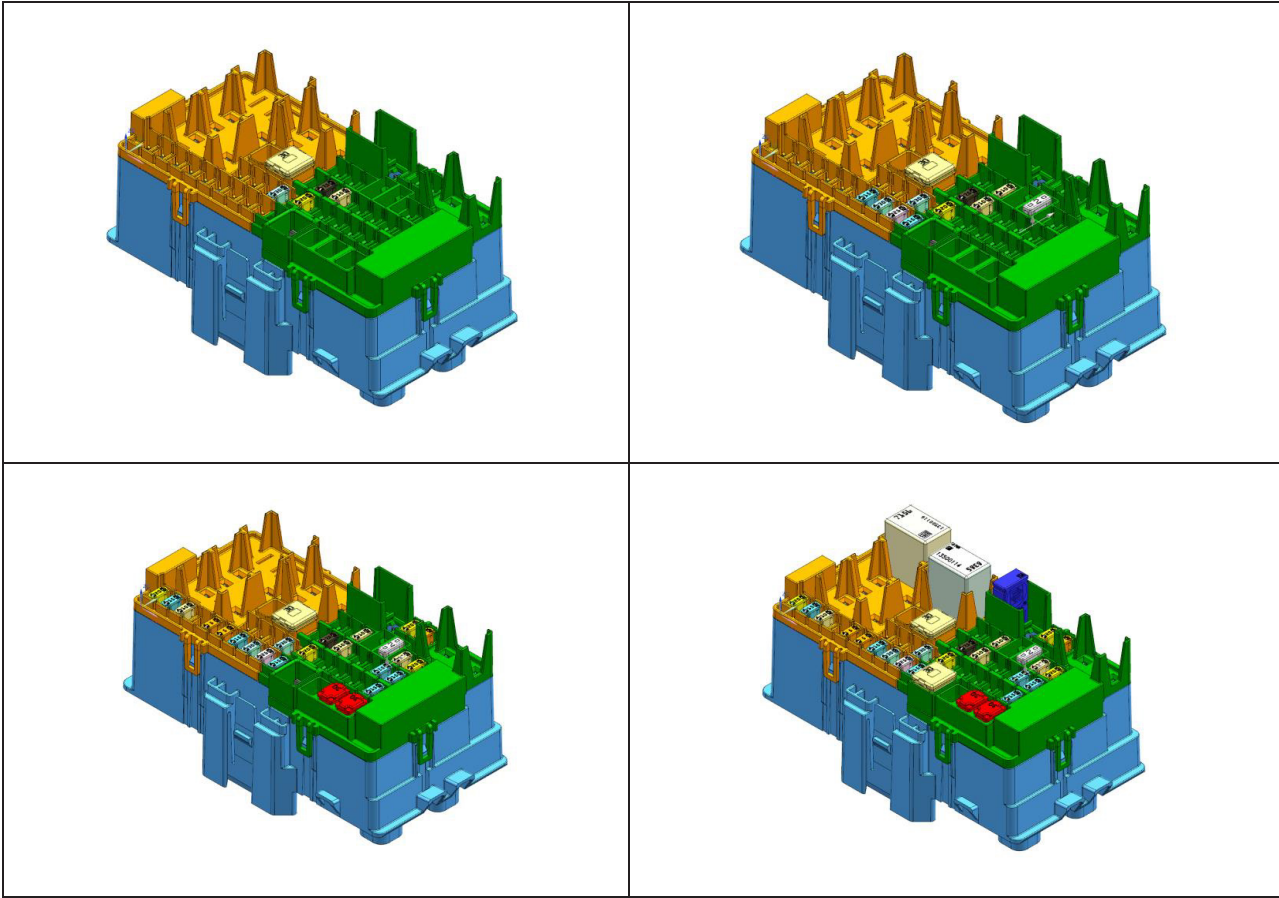

Dabei setzen Sie zunächst die Geräte mit dem niedrigsten Profil in der Gehäusemitte ein.

Dann fahren Sie mit den Geräten mit höherem Profil fort.

Wie bei den Klemmen beginnen Sie mit dem Einsetzen in der Gehäusemitte.

DATE	REVISION	AUTH	DR
25MY17	Initial Release - Frank Lertz	N/A	

TITLE
<b>INSTALLATION INSTRUCTIONS Assembly / Disassembly Instructions</b>
PART NO. <b>23322679</b> SHEET <b>78 OF 84</b>

**Anbringen der Kabelabdeckung**

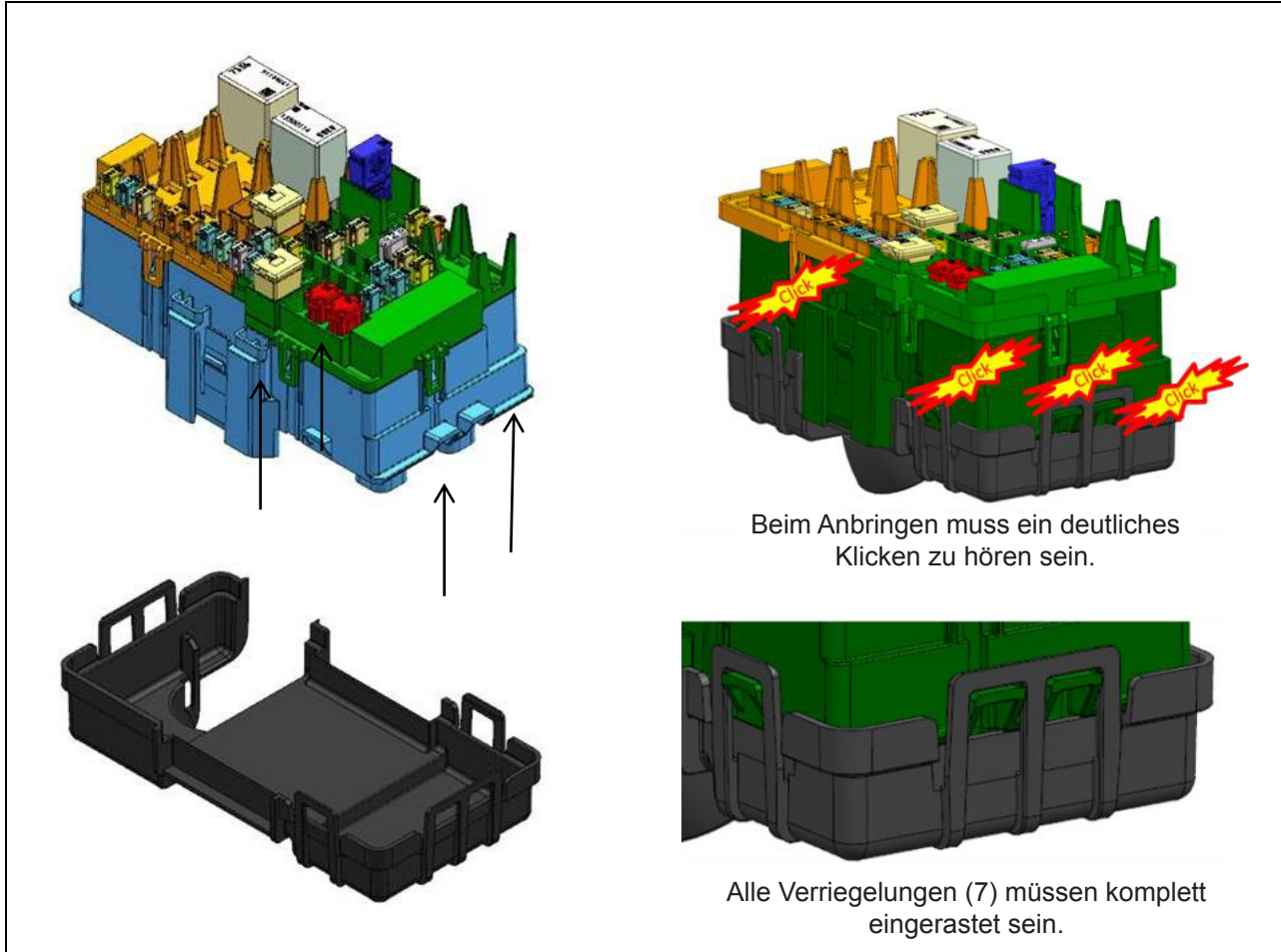

Beim Anbringen muss ein deutliches Klicken zu hören sein.

Alle Verriegelungen (7) müssen komplett eingerastet sein.

Biegen Sie die Kabel in die erforderliche Verlegeposition des Kabelsatzes.  
 Bringen Sie die modellspezifische Kabelabdeckung an und führen Sie den Kabelbinder durch die entsprechenden Schlitze.

ALL INFORMATION WITHIN ABOVE BORDER TO BE PRINTED EXACTLY AS SHOWN ON 8.5 x 11 WHITE 16 POUND NON-BOND RECYCLABLE PAPER. PRINT ON BOTH SIDES, EXCLUDING TEMPLATES. TO BE UNITIZED IN ACCORDANCE WITH GM SPECIFICATIONS.

DATE	REVISION	AUTH	DR
25MY17	Initial Release - Frank Lertz	N/A	

<b>INSTALLATION INSTRUCTIONS</b>	
<b>Assembly / Disassembly Instructions</b>	
PART NO.	<b>23322679</b>
SHEET	<b>79</b> OF <b>84</b>

### Demontage des elektrischen Verteilers

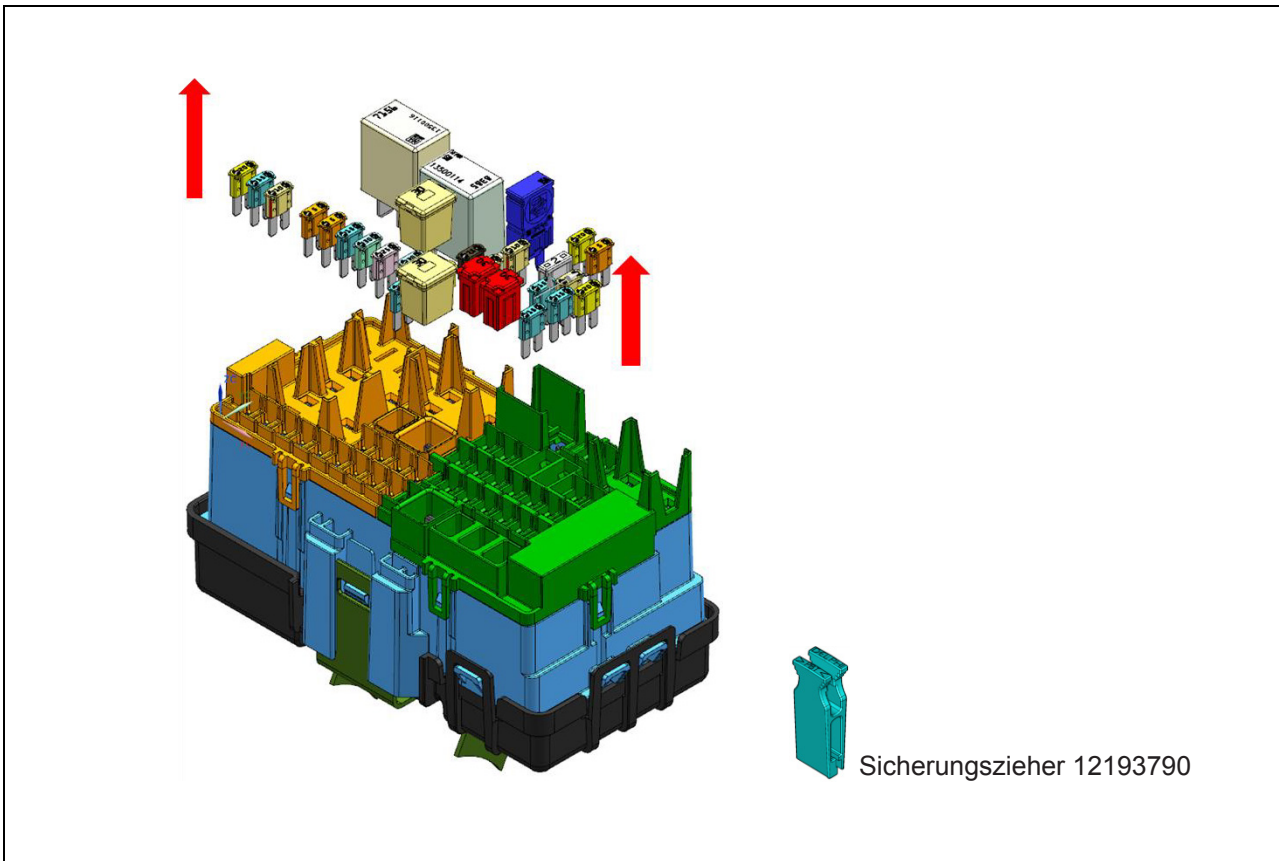

Entfernen Sie alle Geräte. Verwenden Sie dafür den Delphi-Sicherungszieher 12193790 (empfohlen).

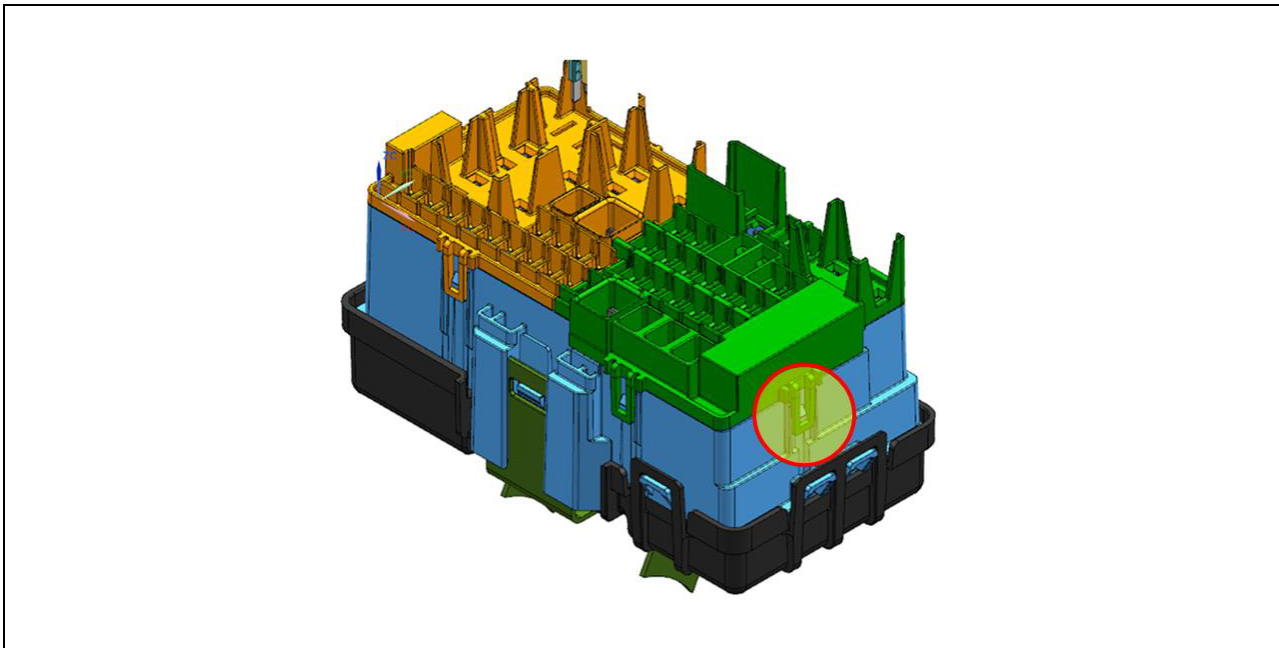

Heben Sie die PLR-Verriegelungen an.  
Sie können während des Betriebs kaputtgegangen sein. Sie sollten Ersatzteile bereithalten.

DATE	REVISION	AUTH	DR
25MY17	Initial Release - Frank Lertz	N/A	

TITLE	<b>INSTALLATION INSTRUCTIONS Assembly / Disassembly Instructions</b>		
PART NO.	<b>23322679</b>	SHEET	<b>80 OF 84</b>

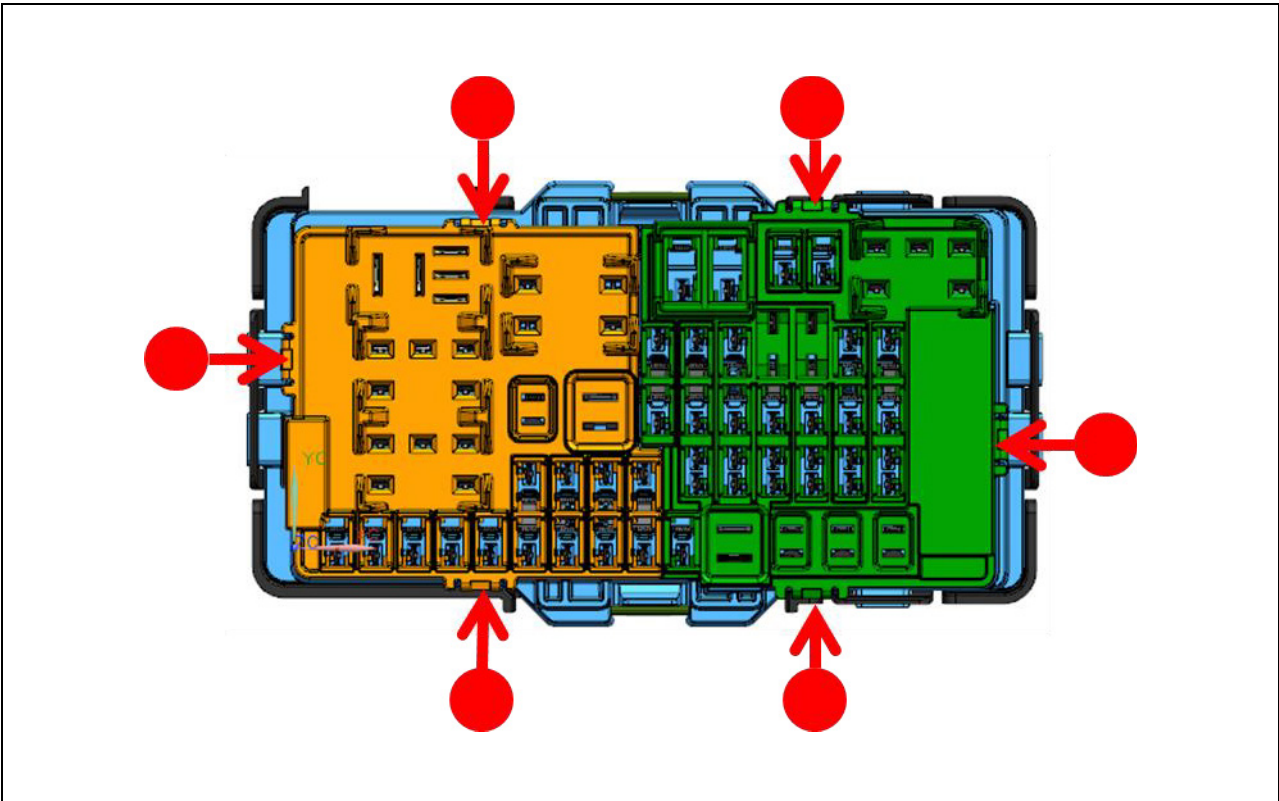

Jeder PLR kann mindestens 3 Verriegelungen an oder in der Nähe der mit den roten Kreisen und Pfeilen markierten Stellen haben.

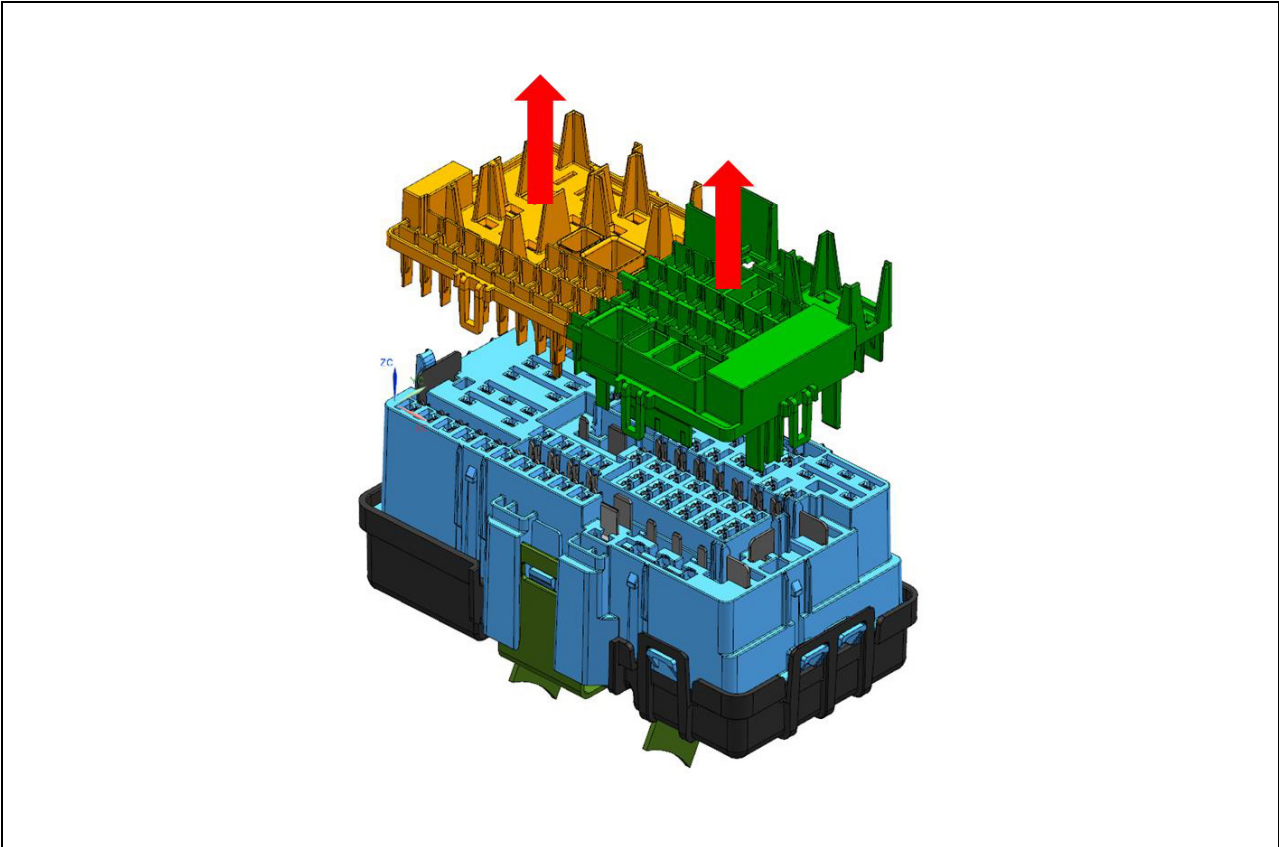

Entfernen der PLRs

**Assembly / Disassembly Instructions**

IR 25MY17 PART NO. **23322679** SHEET **81** OF **84**

ALL INFORMATION WITHIN ABOVE BORDER TO BE PRINTED EXACTLY AS SHOWN ON 8.5 x 11 WHITE 16 POUND NON-BOND RECYCLABLE PAPER. PRINT ON BOTH SIDES, EXCLUDING TEMPLATES. TO BE UNITIZED IN ACCORDANCE WITH GM SPECIFICATIONS.

DATE	REVISION	AUTH	DR
25MY17	Initial Release - Frank Lertz	N/A	

<b>INSTALLATION INSTRUCTIONS</b>	
<b>Assembly / Disassembly Instructions</b>	
PART NO.	SHEET <b>81</b> OF <b>84</b>
<b>23322679</b>	

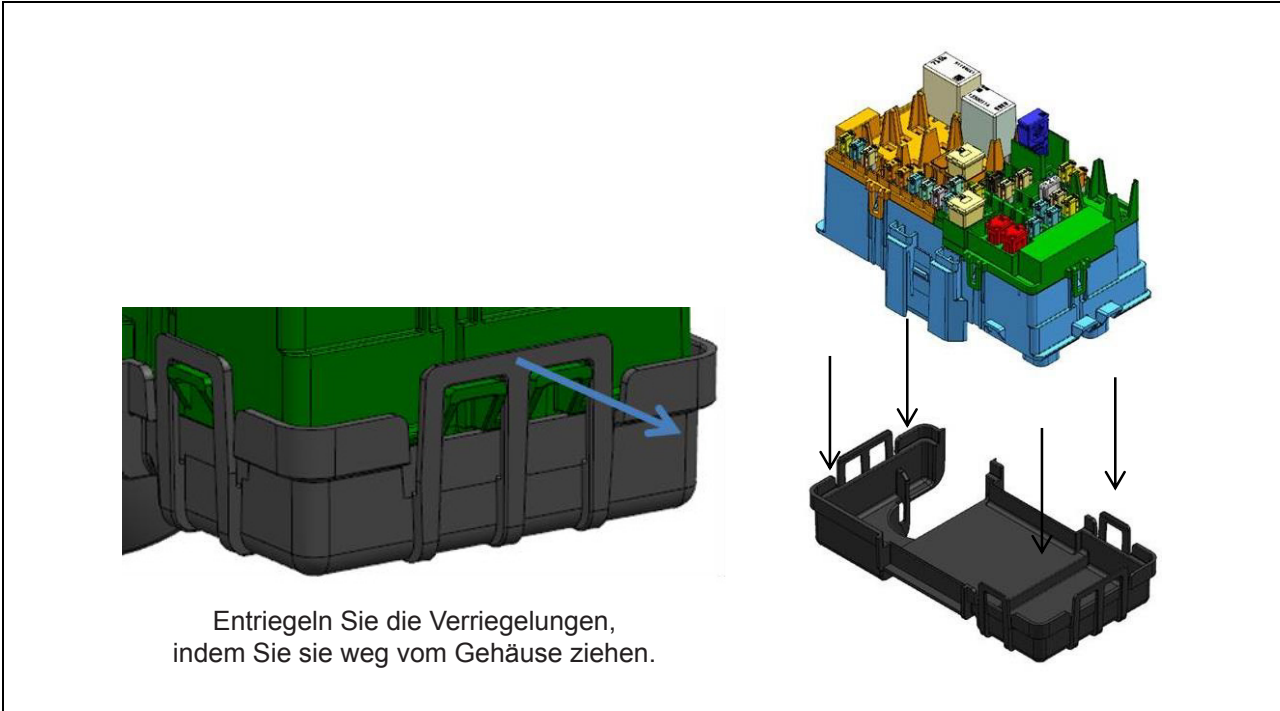

Entriegeln Sie die Verriegelungen, indem Sie sie weg vom Gehäuse ziehen.

Entfernen Sie die Kabelabdeckung.

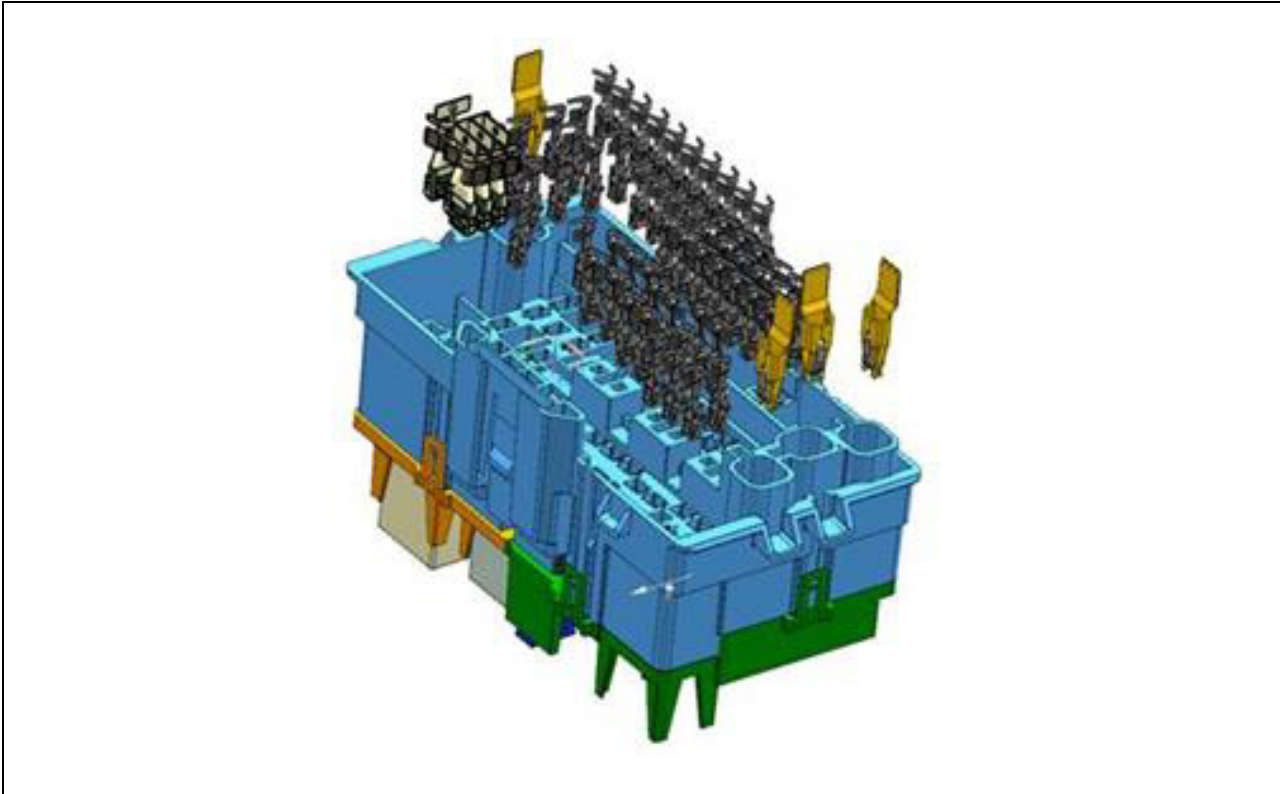

Entfernen Sie mit folgendem Verfahren nacheinander die Klemmen:

<b>Assembly / Disassembly Instructions</b>					<b>IR 25MY17</b>	PART NO. <b>23322679</b>	SHEET <b>82</b> OF <b>84</b>	
ALL INFORMATION WITHIN ABOVE BORDER TO BE PRINTED EXACTLY AS SHOWN ON 8.5 x 11 WHITE 16 POUND NON-BOND RECYCLABLE PAPER. PRINT ON BOTH SIDES, EXCLUDING TEMPLATES. TO BE UNITIZED IN ACCORDANCE WITH GM SPECIFICATIONS.	DATE	REVISION	AUTH	DR	<b>INSTALLATION INSTRUCTIONS</b> <b>Assembly / Disassembly Instructions</b>			
	25MY17	Initial Release - Frank Lertz	N/A					
					PART NO.	<b>23322679</b>	SHEET	<b>82</b> OF <b>84</b>

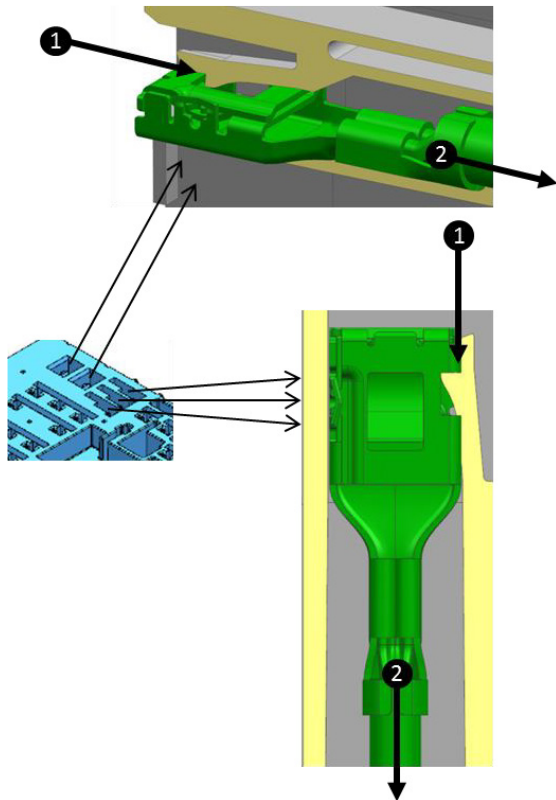

Klemme 630F (Logistik-Relais).

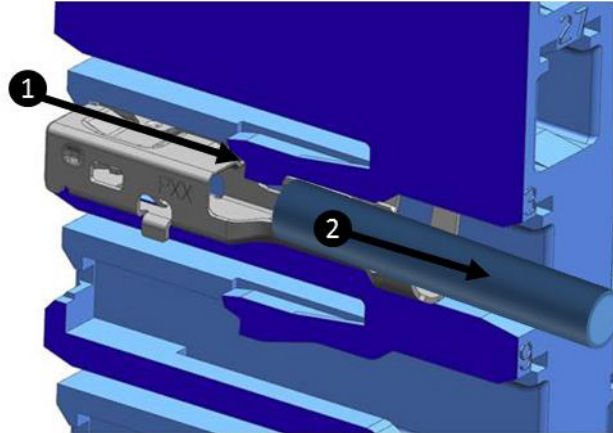

Klemme 280F  
(Sicherungen, Trennschalter und Relais).

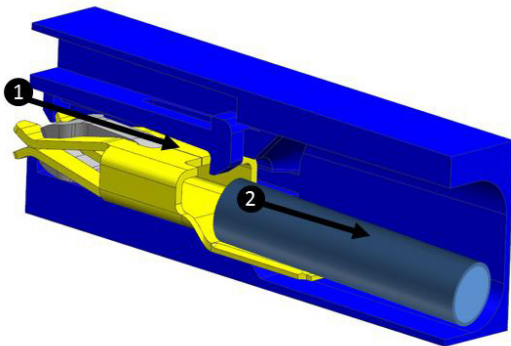

Klemme 630HC (Sammelschienen).

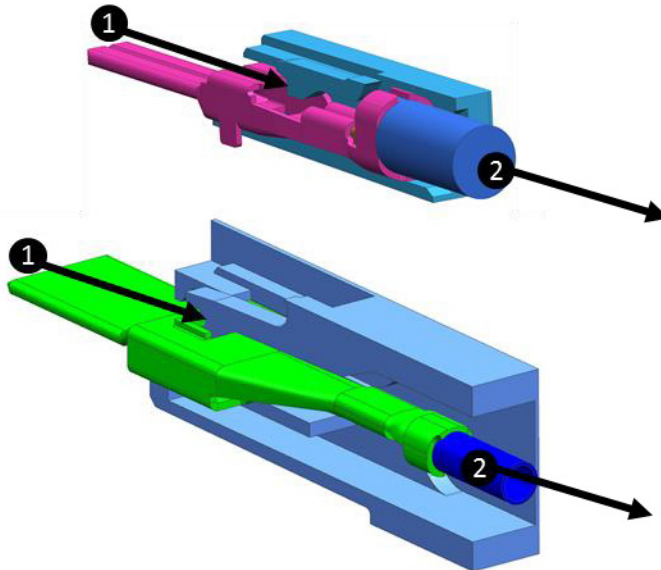

Klemme 630M (J-Case-Sicherungen).  
Klemme 280M (Sicherungen Typ M).

**Reihenfolge der Schritte**

1. Lokalisieren Sie die Flex-Lock-Vorrichtung im Kunststoffgehäuse, und heben Sie sie an.
2. Ziehen Sie am Kabel, um die Klemme zu lösen.

DATE	REVISION	AUTH	DR
25MY17	Initial Release - Frank Lertiz	N/A	

TITLE	PART NO.	SHEET
INSTALLATION INSTRUCTIONS Assembly / Disassembly Instructions	23322679	83 OF 84



**Klemme 630HC (Sammelschienen)**

**Reihenfolge der Schritte**

1. Lokalisieren Sie die Flex-Lock-Vorrichtung im Kunststoffgehäuse, und heben Sie sie an.
2. Ziehen Sie am Kabel, um die Klemme zu lösen.

**Empfohlene Reparaturwerkzeug**

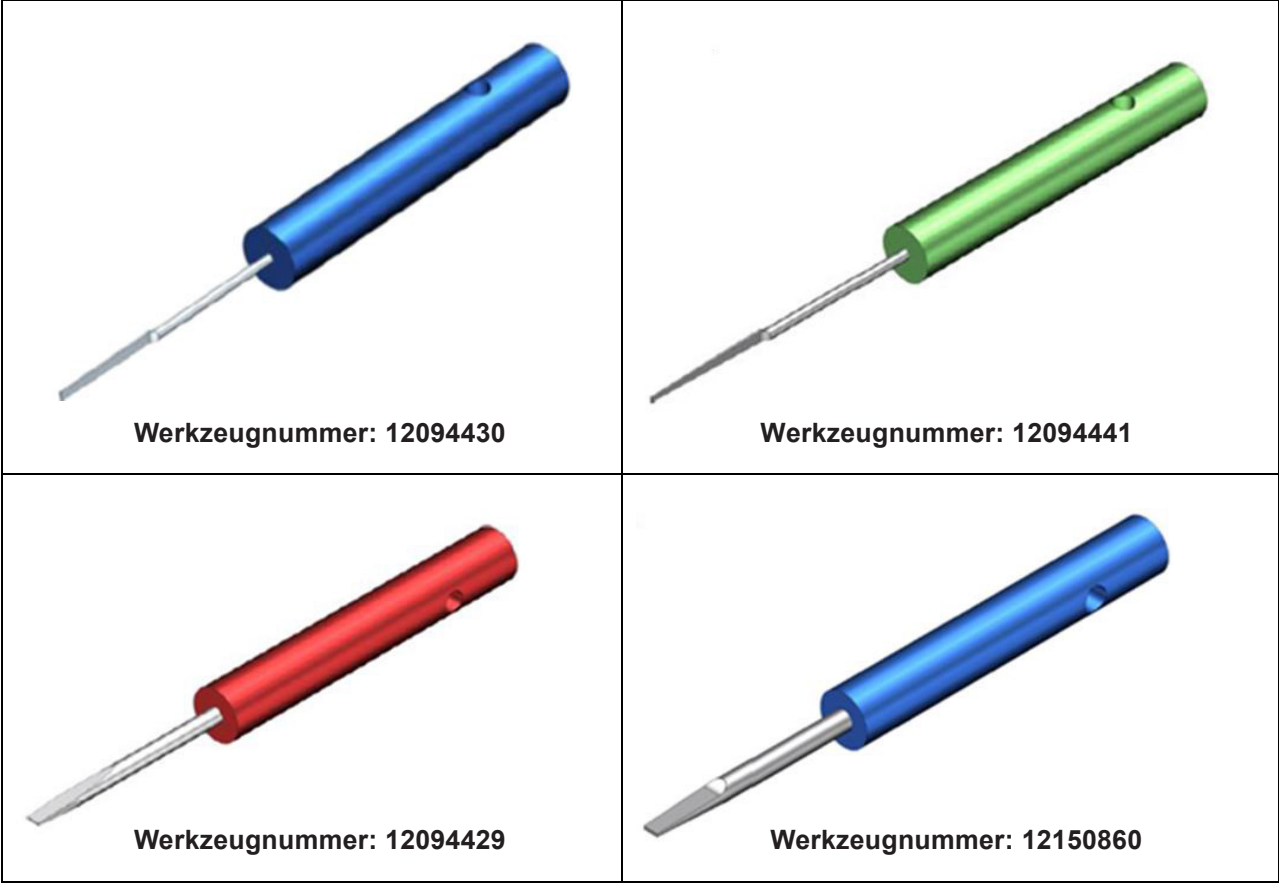

DATE	REVISION	AUTH	DR
25MY17	Initial Release - Frank Lertz	N/A	