



Buick Splash Guard - Rear

Please read instructions thoroughly before starting.

Tools Required

- T15 Torx Screw Driver
- Drill
- 13/64" (5.0 mm) Drill Bit
- Clean Cloth/Rag

Parts Required from Package Contents

Description	Quantity
Left Hand Splash Guard	1
Right Hand Splash Guard	1
M4.2 x 25 Screw	6
M4.2 x 30 Screw	2
M4.2 U-Nut	4
Spacer	2

Installation Procedure

Note: Do not use power tools to install splash guard fasteners

1. Remove tire.
2. Clean and degrease body panel where splash guards are to be located.
3. Remove two (2) existing screws at locations (A) and (B) and discard. **See figure 1.**
4. Apply one (1) adhesive spacer to back of splash guard centered on hole at location (B). **See figure 2.**
5. Place splash guard to vehicle and install 30 mm screw at location (B), and install 25 mm screw at location (A). **See figure 2.**
6. While holding the splash guard firmly to the vehicle to remove any gaps, carefully drill a 13/64" (5.0 mm) hole at locations (C) and (D). **See figure 2 and figure 3.**
7. Install 25 mm screw at locations (C) and (D) using U-nuts for attachment. **See figure 4 and figure 5.**
8. Repeat for other side.
9. Guards can be cleaned with any commercially available cleaner.

NOTE: Max torque on M4.2 Screw is 3.0 N m

FIGURE 1

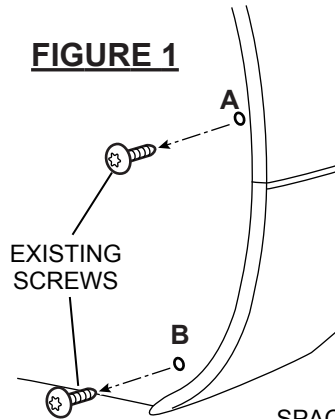

FIGURE 2

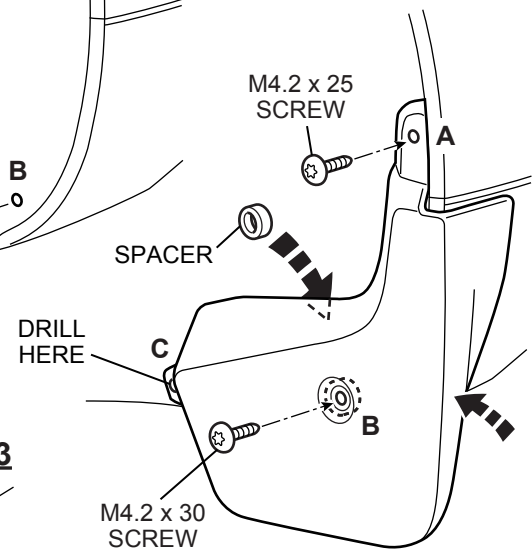

FIGURE 3

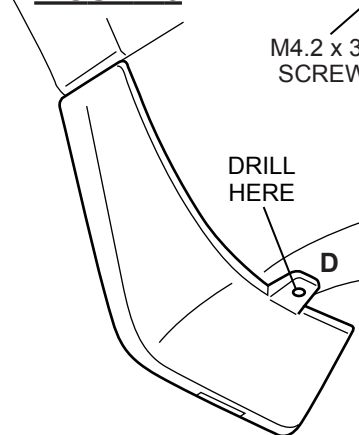

FIGURE 4

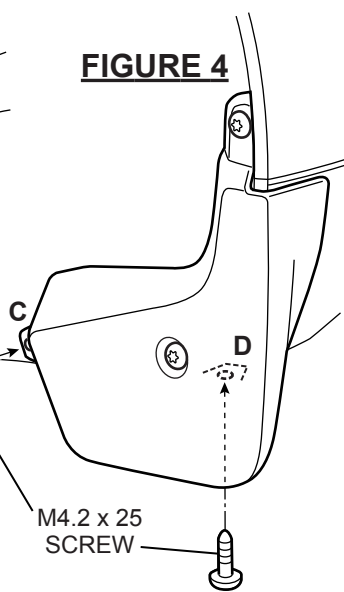
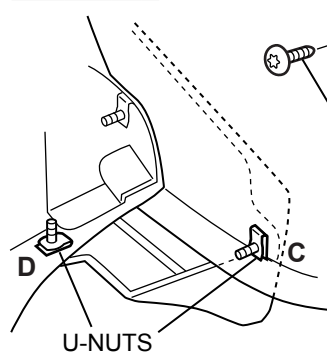

FIGURE 5



VIEW FROM INSIDE

Splash Guard - Front

IR 19FE20

PART NO. 84559710

SHEET 1 OF 3

ALL INFORMATION WITHIN ABOVE BORDER TO BE PRINTED EXACTLY AS SHOWN ON 8.5x11 WHITE 18 POUND, NON-BOND RECYCLEABLE PAPER PRINT ON BOTH SIDES EXCLUDING TEMPLATES. TO BE UNITIZED IN ACCORDANCE WITH OMSPO SPECIFICATIONS

DATE	REVISION	AUTH	DR	TITLE
				INSTALLATION INSTRUCTIONS
				Buick Splash Guard - Rear

PART NO. 84559713

SHEET 1 OF 3