

Floor Auxiliary Mat Set Installation

Installation Instruction Part Number

20980731

Kit Contents (Second Row Bench Seating)

Note: For second row executive / bucket seating, proceed to the second row executive / bucket seating section halfway through these instructions.

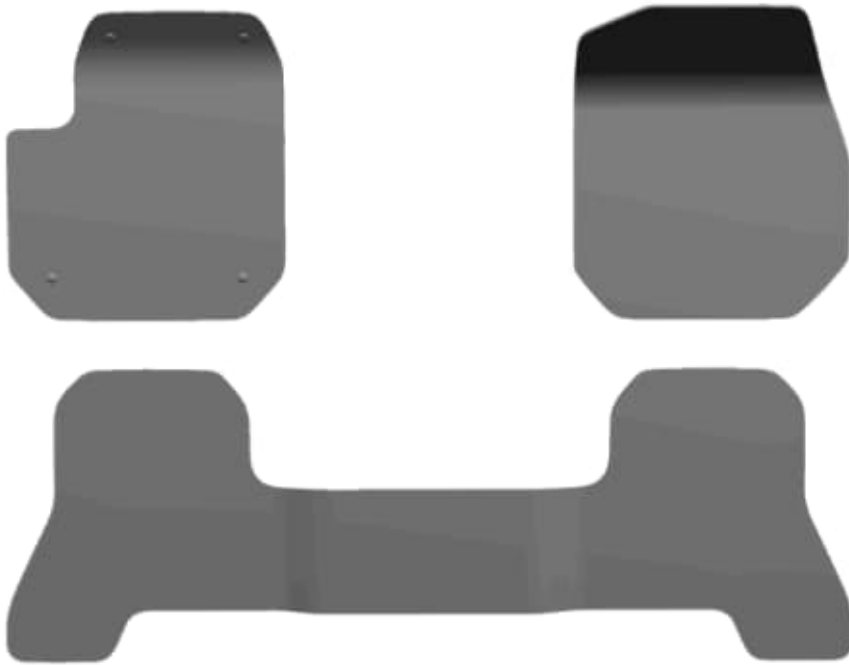

Procedure (Second Row Bench Seating)

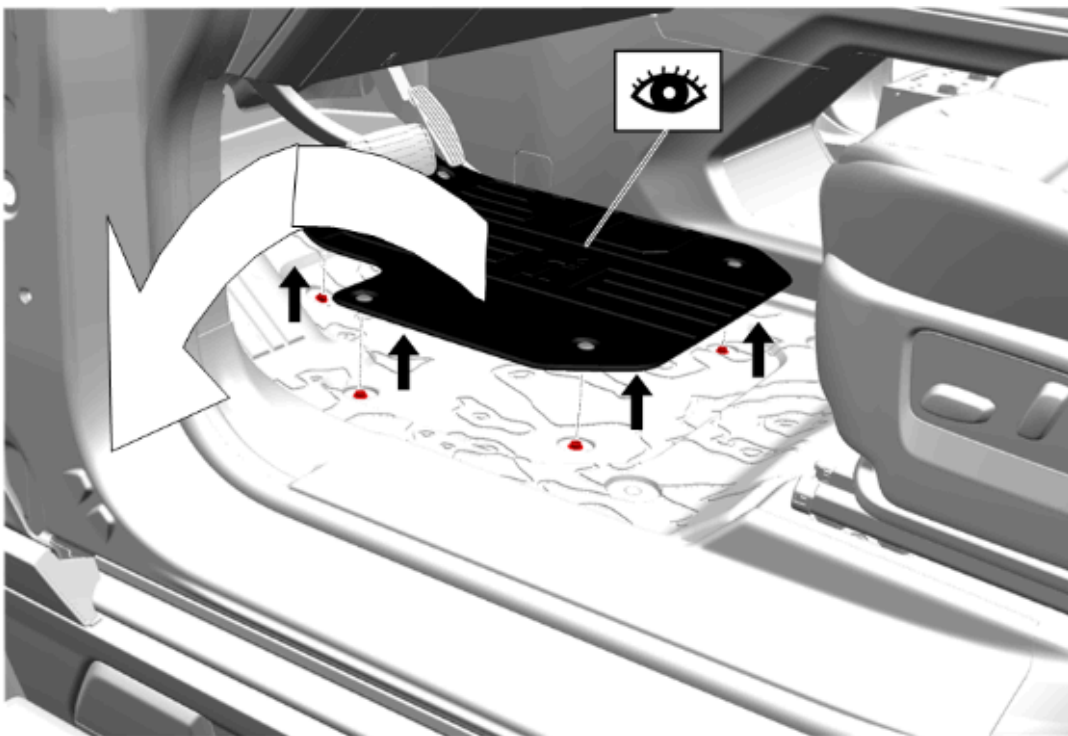

1. Remove the production installed driver side front floor mat.

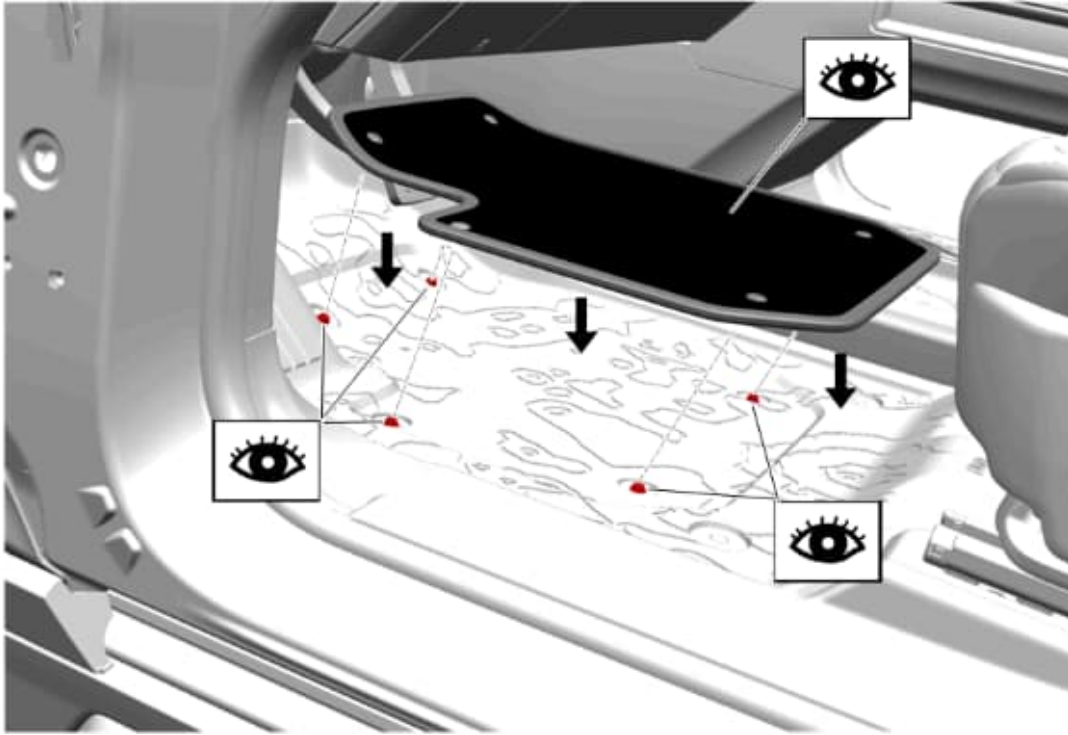

Caution: DO NOT use a floor mat that is flipped over with the bottom-side up.

Caution: DO NOT stack one floor mat over another floor mat.

2. Install the accessory driver side front floor mat to the floor retainers.

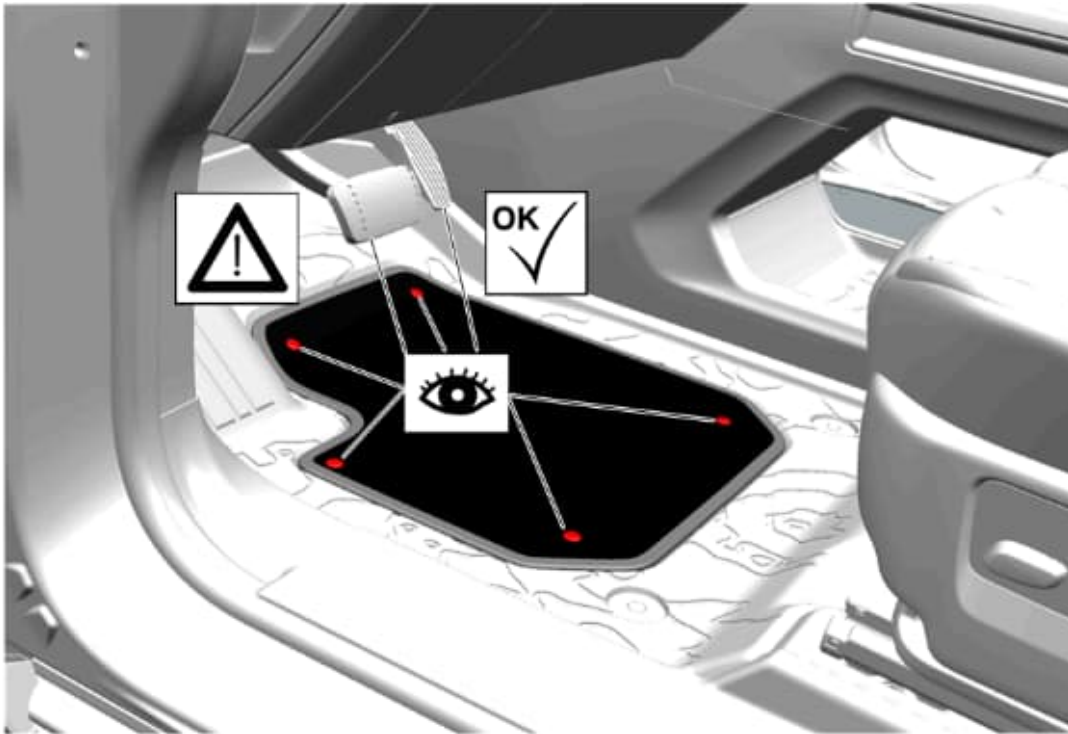

Caution: Check the operation of the accelerator, brake, and clutch (if applicable) pedals to assure that the floor mat does not interfere with them.

3. Check and confirm that the driver side front floor mat retainers are all engaged.

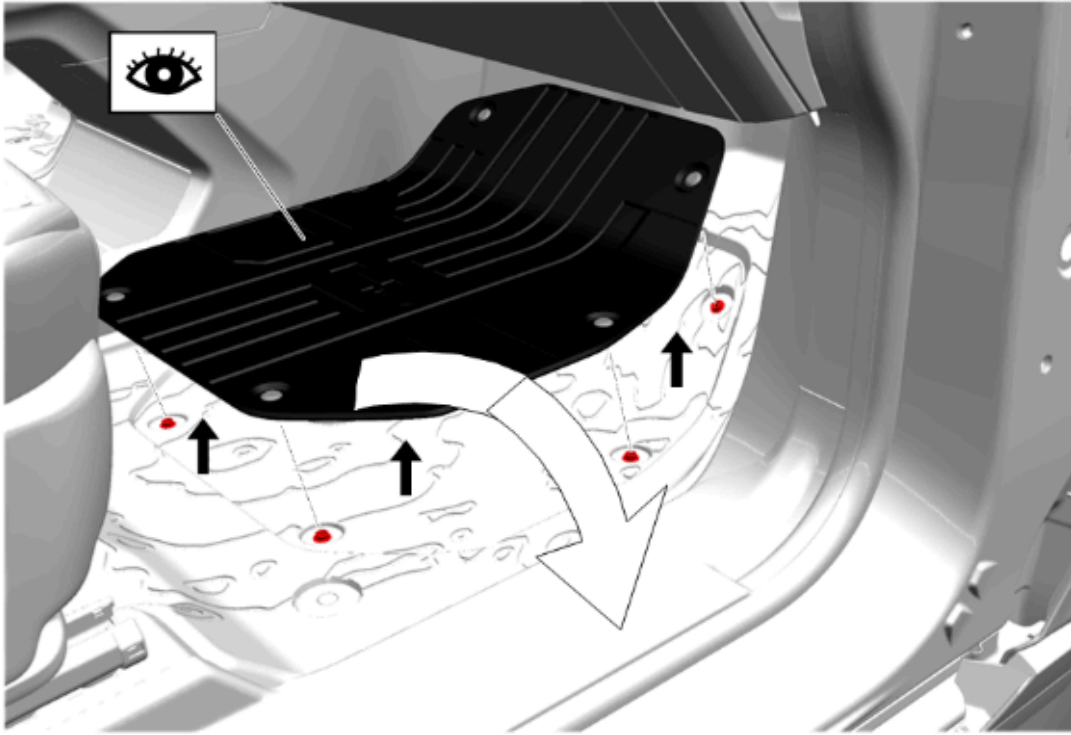

4. Remove the production installed passenger side front floor mat.

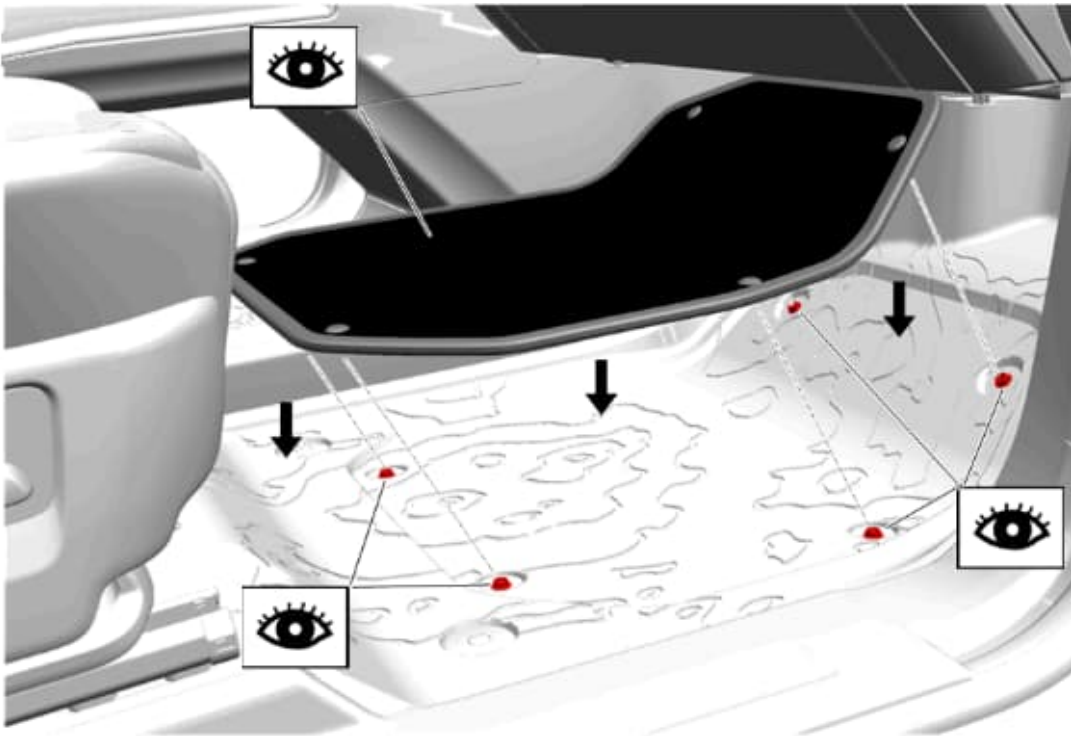

5. Install the accessory passenger side front floor mat to the floor retainers.

6. Check and confirm that the passenger side front floor mat retainers are all engaged.

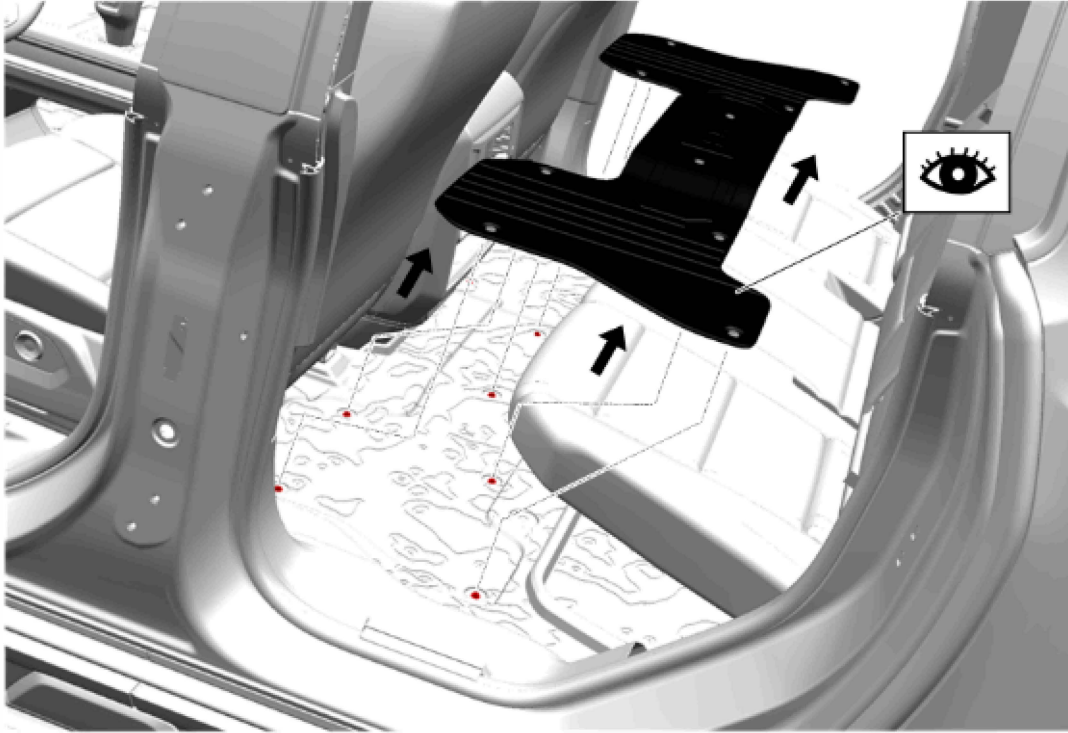

7. Remove the production installed second row floor mat.

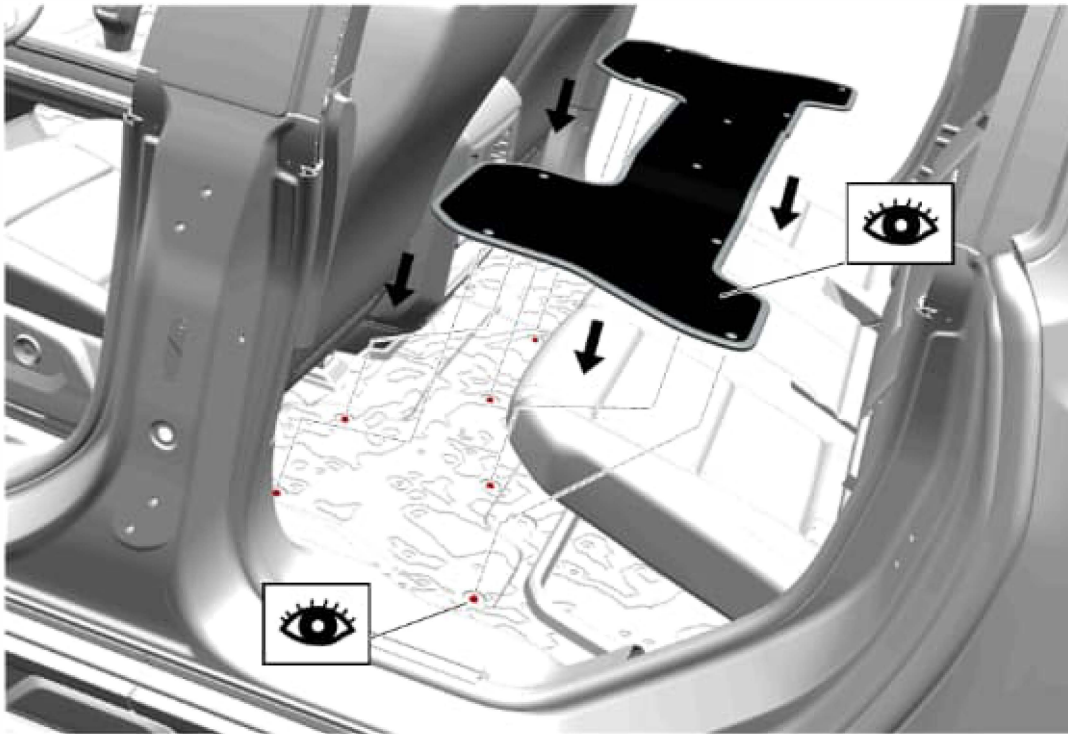

8. Install the accessory second row floor mat to the floor retainers.

9. Check and confirm that the second row floor mat retainers are all engaged.

Kit Contents (Second Row Executive / Bucket Seating)

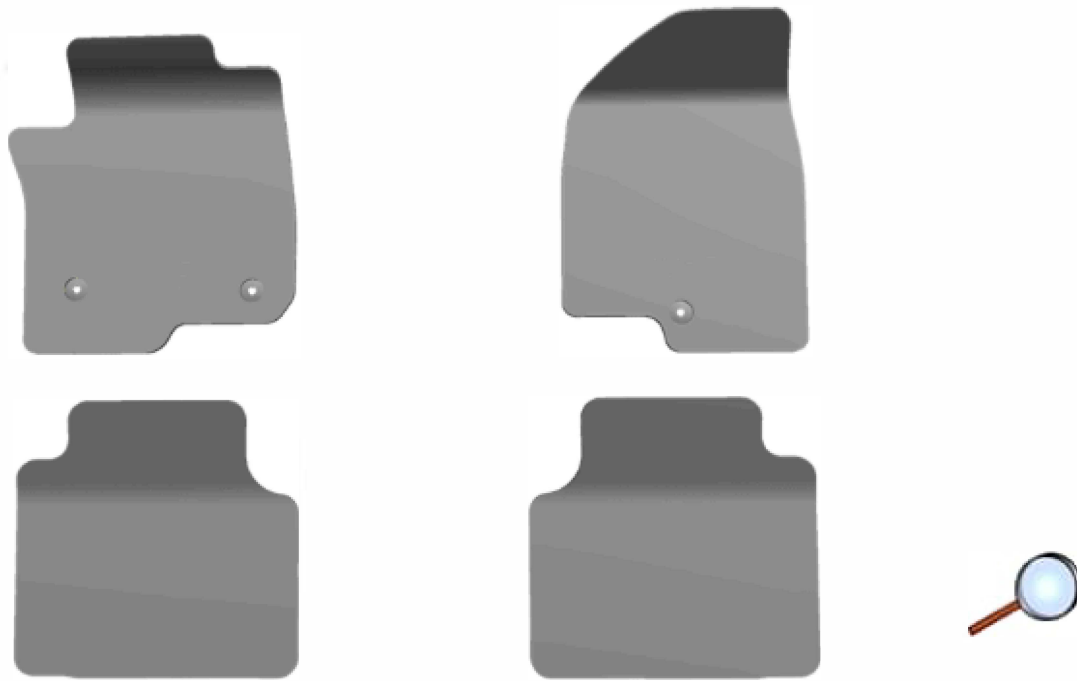

Procedure (Second Row Executive / Bucket Seating)

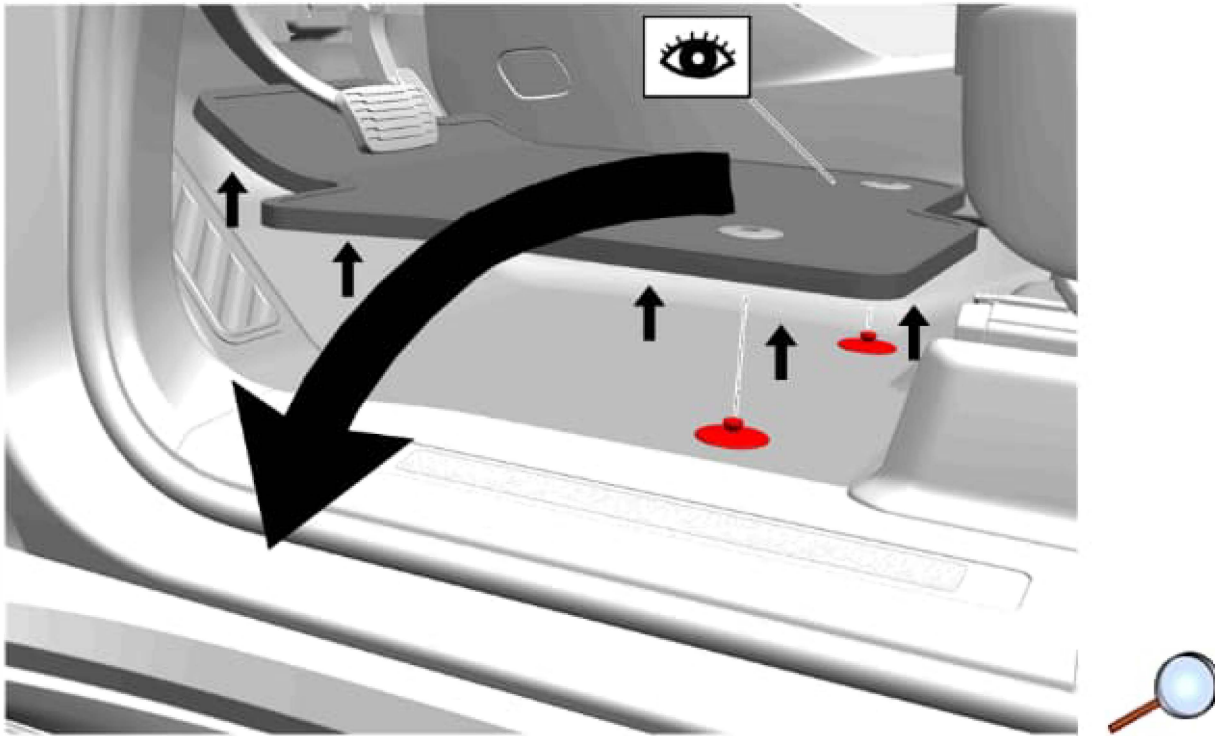

1. Remove the production installed driver side front floor mat.

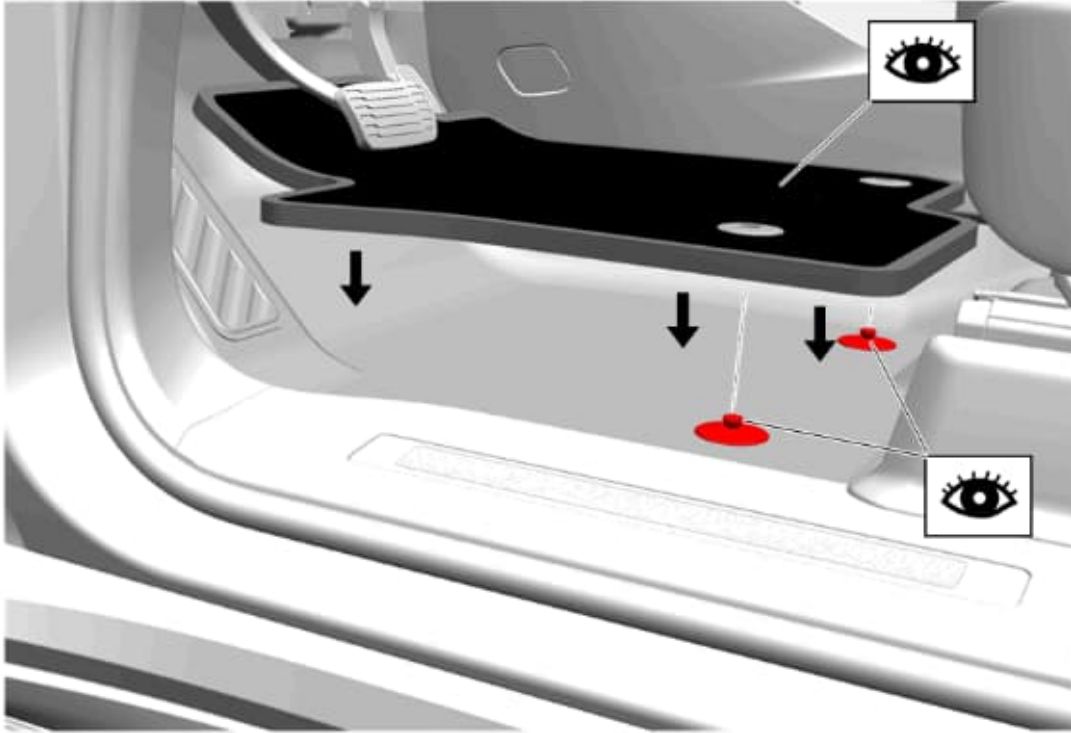

Caution: DO NOT use a floor mat that is flipped over with the bottom-side up.

Caution: DO NOT stack one floor mat over another floor mat.

2. Install the accessory driver side front floor mat to the floor retainers.

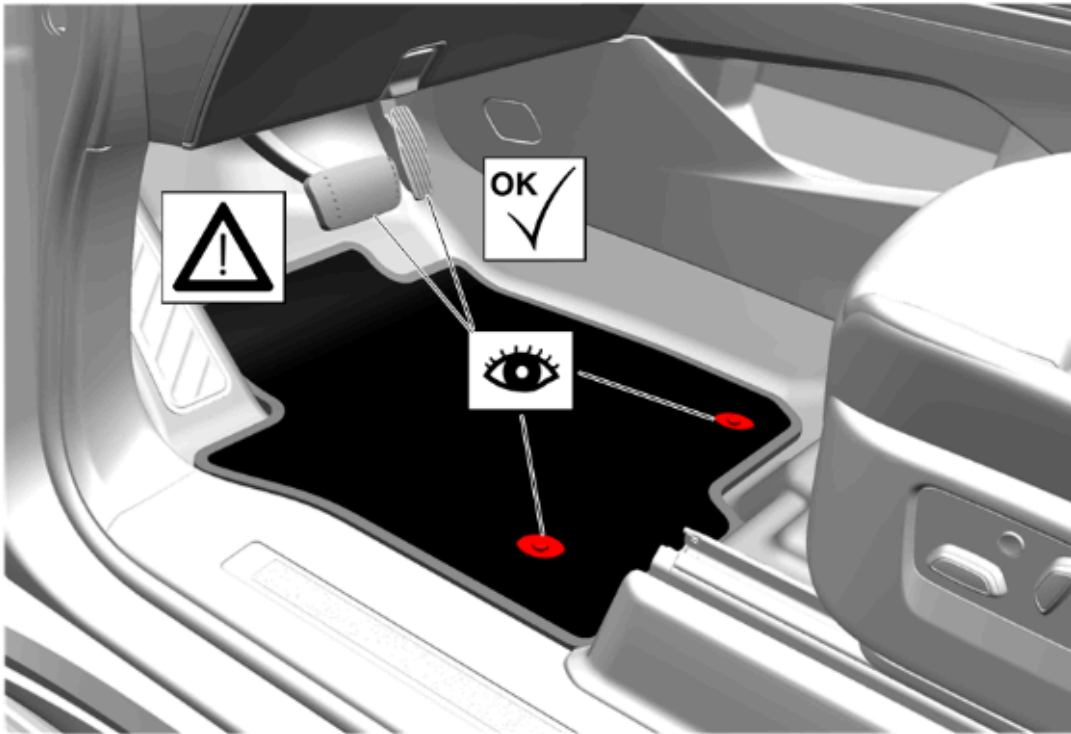

Caution: Check the operation of the accelerator, brake, and clutch (if applicable) pedals to assure that the floor mat does not interfere with them.

3. Check and confirm that the driver side front floor mat retainers are all engaged.

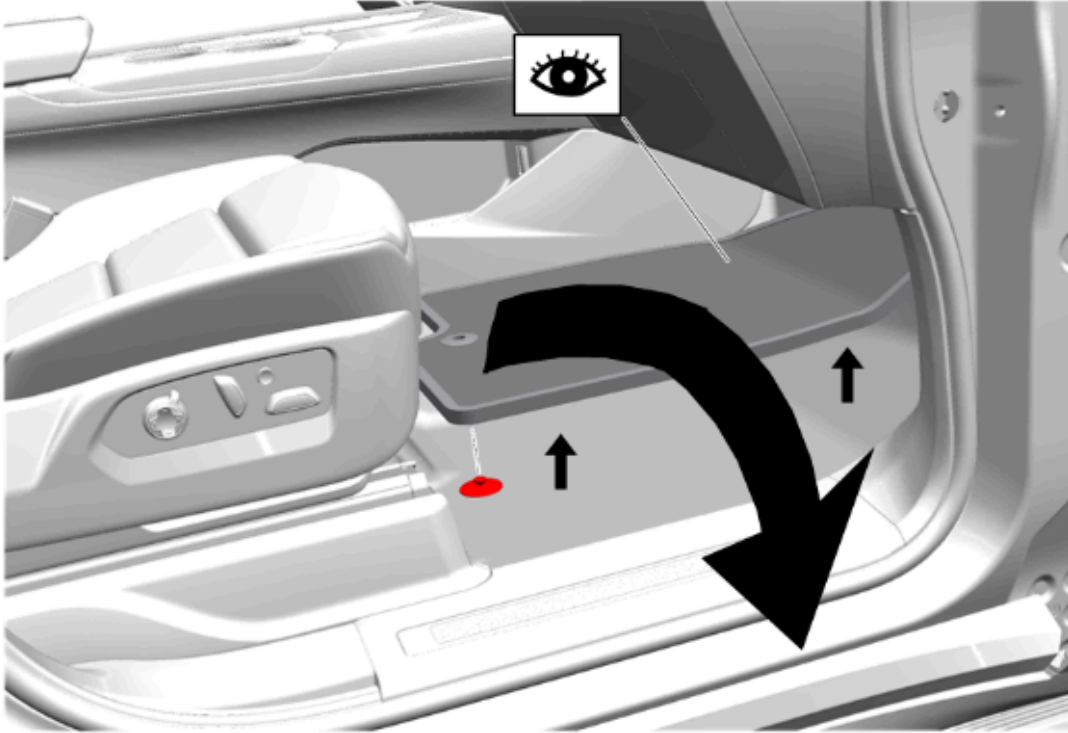

4. Remove the production installed passenger side front floor mat.

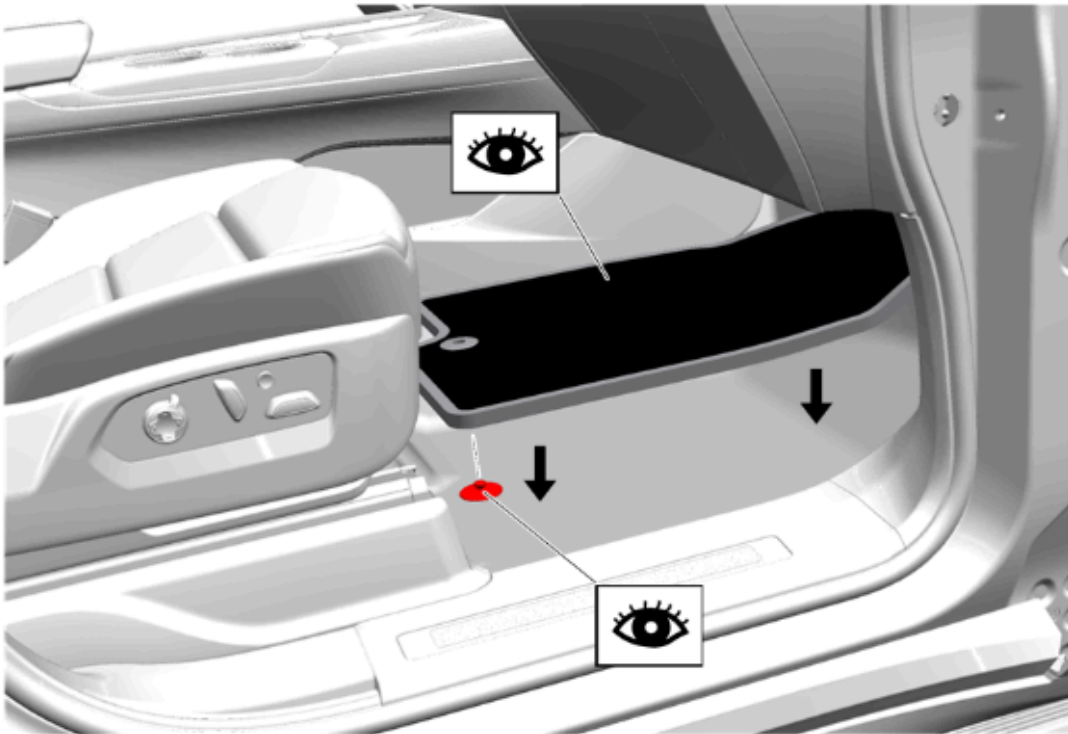

5. Install the accessory passenger side front floor mat to the floor retainers.

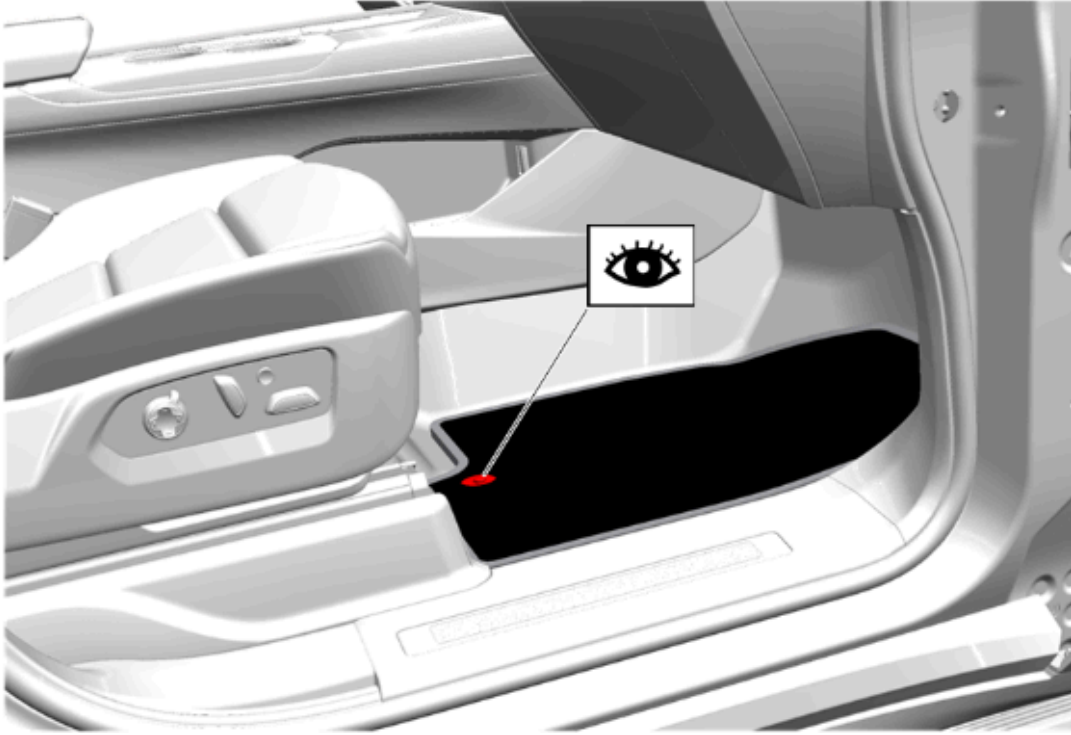

6. Check and confirm that the passenger side front floor mat retainers are all engaged.

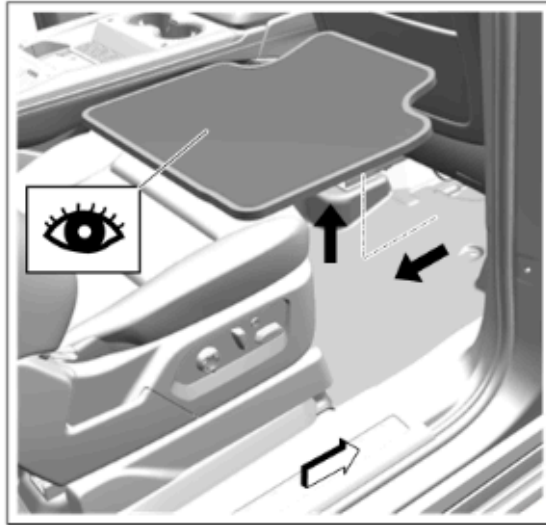
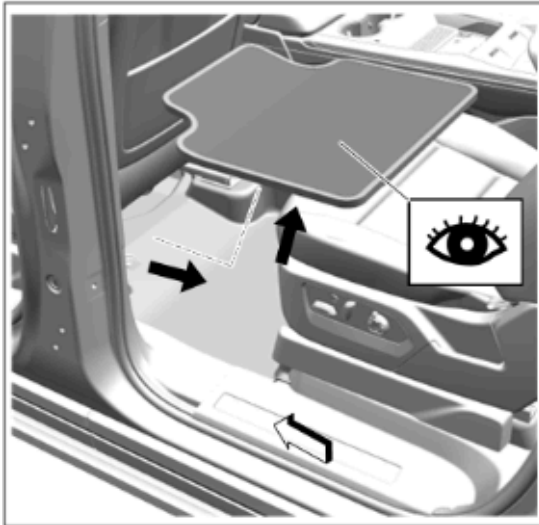

7. Remove the production installed second row driver and passenger floor mat.

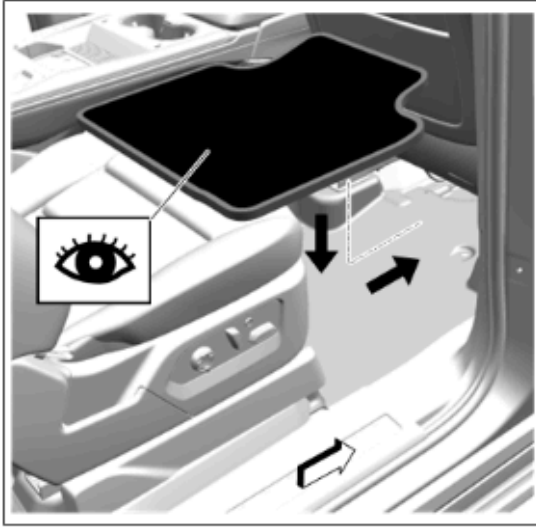
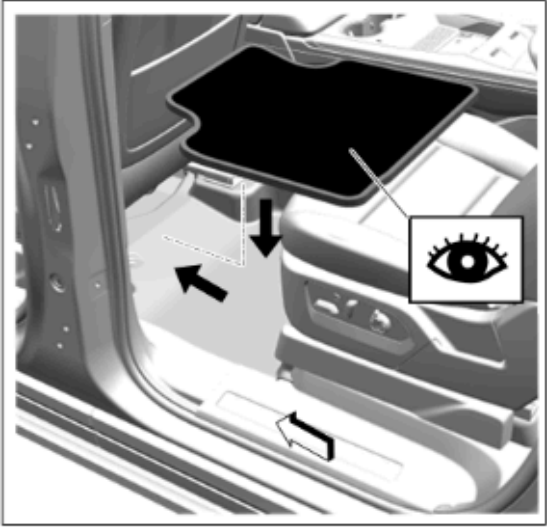

8. Install the accessory second row driver and passenger floor mat.