

Front Side Door Sill Trim Plate Package Installation

Installation Instructions Part Number

23200136

Note: Please review the entire procedure before trying to perform it.

Front Side Door Trim Plate Kit Contents

Qty	Description
1	Left Front Side Door Sill Trim Plate Assembly
1	Right Front Side Door Sill Trim Plate Assembly
8	Tie Straps
1	Wire Harness

Recommended Tools

- Flat Bladed Plastic Trim Tool
- 2mm Width Flat Screwdriver
- 0.8mm Width Flat Screwdriver
- GM Terminal Remover Tool P/N 12152110, 15315247, or 12094429 (7J04899)
- Push-in Retainer Puller
- Electrical Tape
- 13mm Socket
- Trim Removal Tools
- Small Ratchet
- Heat Gun
- Wire Crimp Tool

Procedure

© 2018 General Motors. All rights reserved.

1. Move the front seats to the furthest aft position.

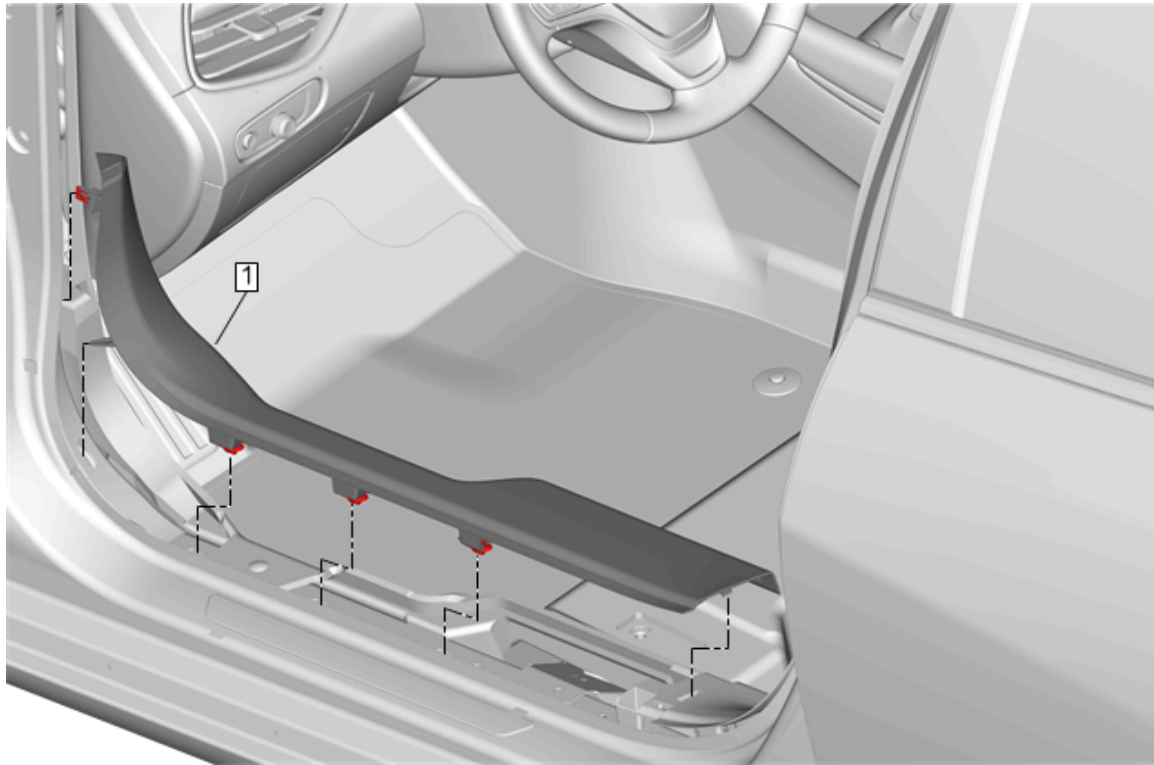

2. Remove the left and right front side door sill garnish moldings (1). Refer to Vehicle Service Manual.

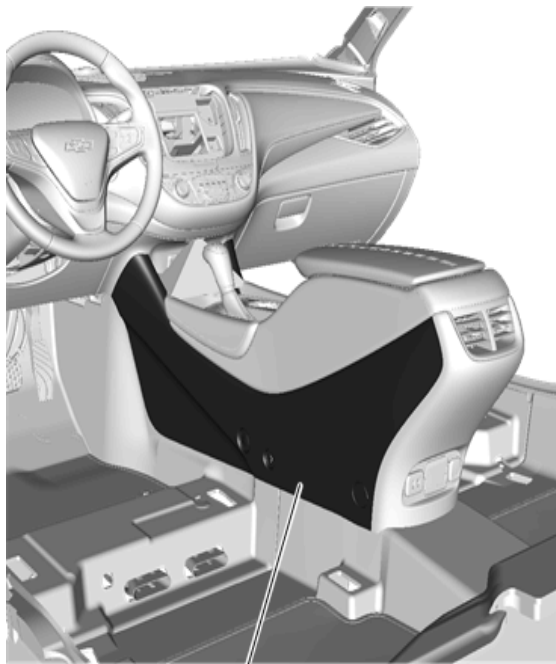

3. Remove the left (1) and right (2) front floor console side panels. Refer to Vehicle Service Manual.

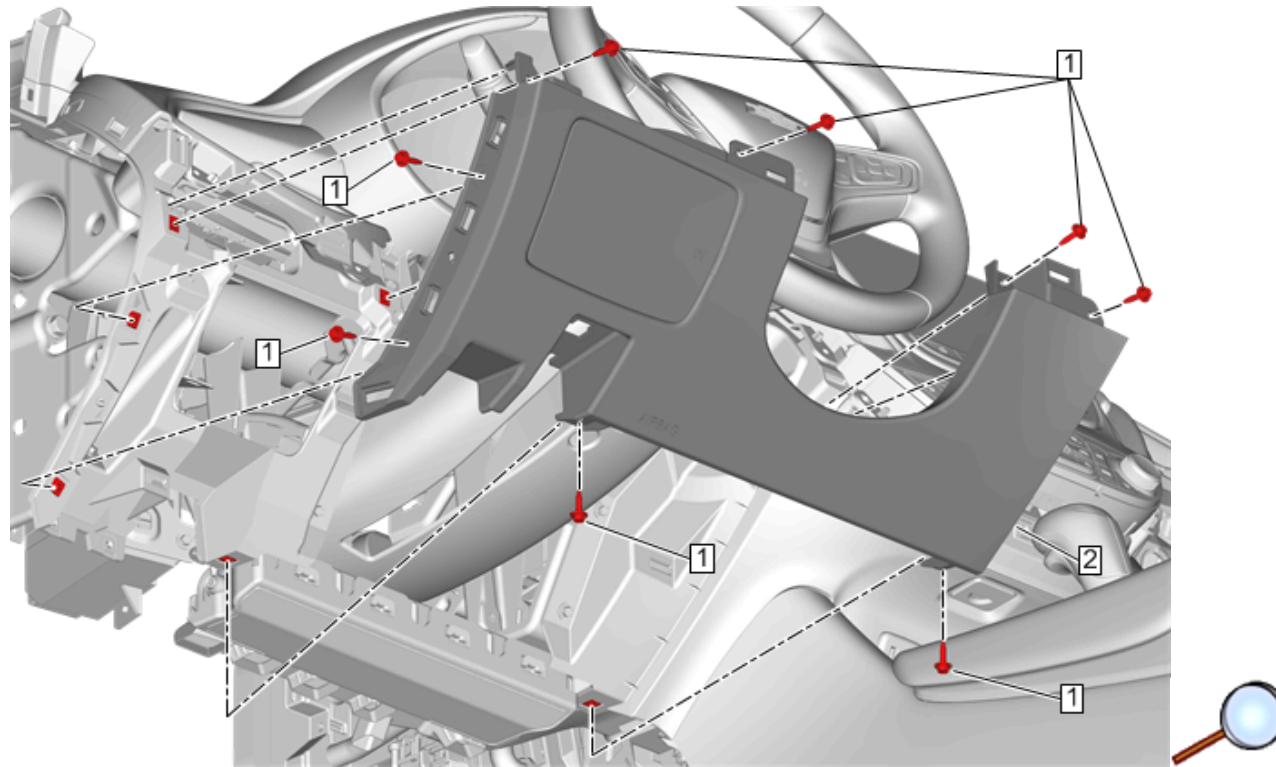

4. Remove the instrument panel knee bolster (2). Refer to Vehicle Service Manual.

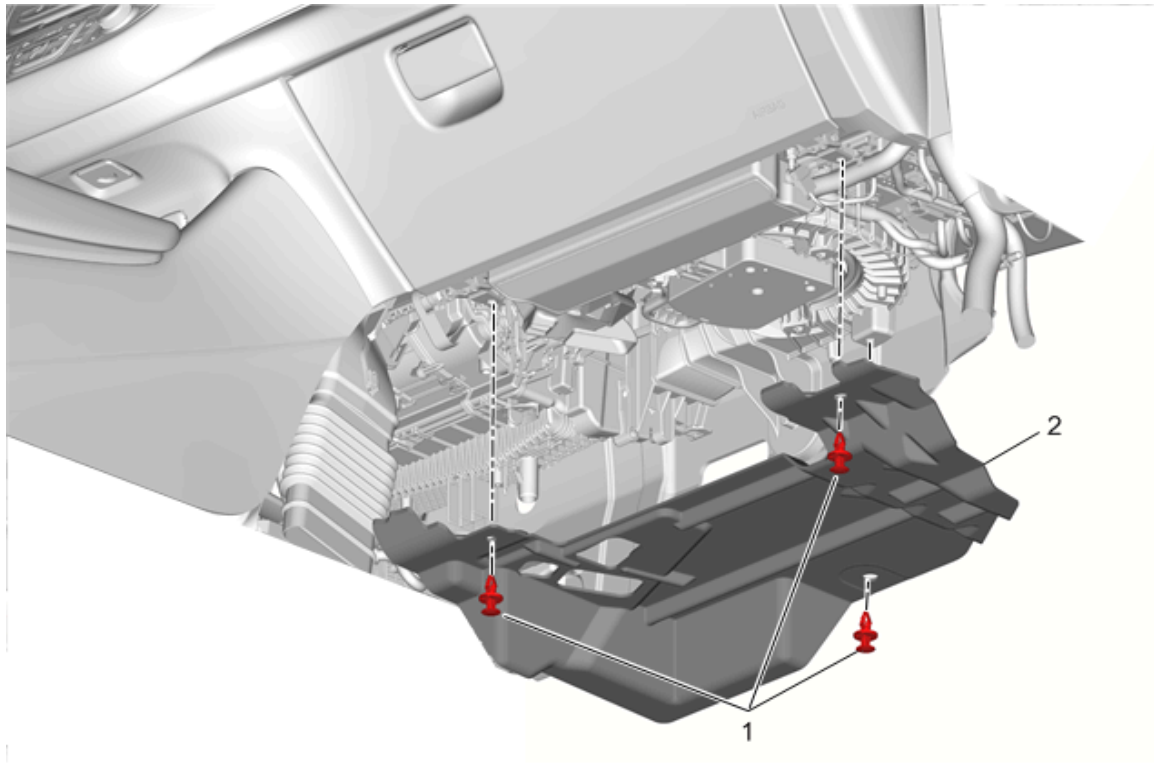

5. Remove the lower trim panel insulator (2). Refer to Vehicle Service Manual.

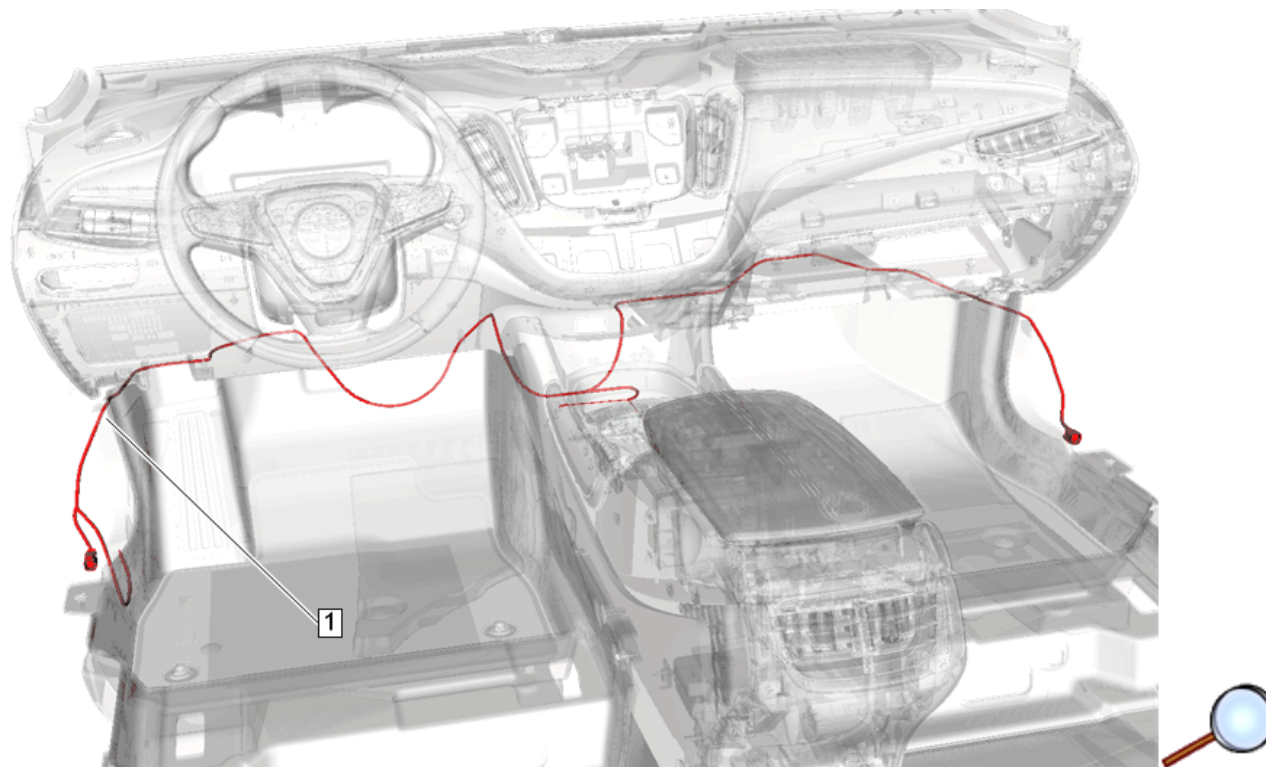

6. Route wiring harness through the vehicle.

- 6.1. Lay the wire harness out on the ground to get an idea how it will fit in the vehicle. The ground eyelet will connect to the left side cowl and the BCM terminals will be just to the right of the center at the center console. The connectors will route rearward to connect to both illuminated sill plates.
- 6.2. Route the harness (1) across the vehicle, from the driver's side toward the passenger sill plate, near the top edge of the carpet. Secure with tie straps in a later step.
- 6.3. To cross the center console, route forward and against the dash panel.

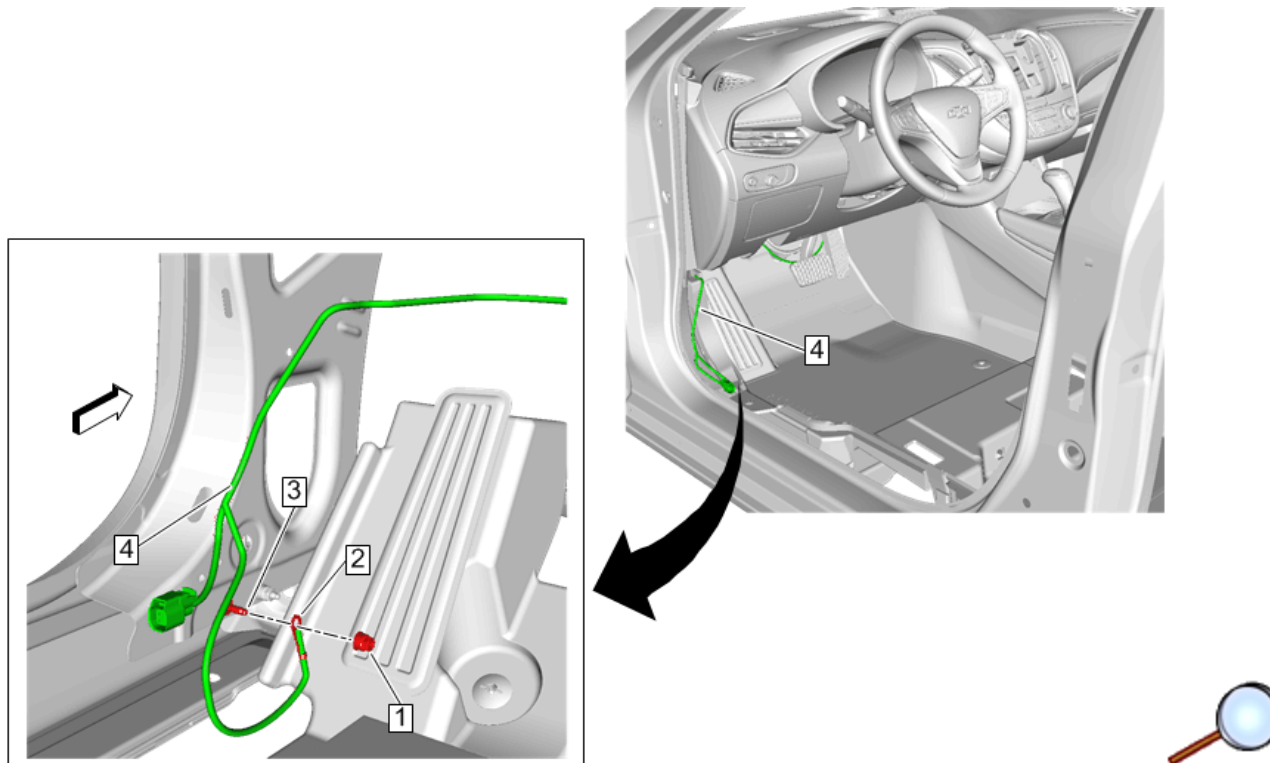

7. Locate an unused ground stud (3) on the driver side cowl. If no unused ground is available, use a ground that has only one eyelet present.
8. Remove the ground nut (1) and install the illuminated sill plate harness (4) ground eyelet (2).

Caution: Use the correct fastener in the correct location. Replacement fasteners must be the correct part number for that application. Fasteners requiring replacement or fasteners requiring the use of thread locking compound or sealant are identified in the service procedure. Do not use paints, lubricants, or corrosion inhibitors on fasteners or fastener joint surfaces unless specified. These coatings affect fastener torque and joint clamping force and may damage the fastener. Use the correct tightening sequence and specifications when installing fasteners in order to avoid damage to parts and systems.
9. Reinstall the ground nut and tighten to 25 N.m using a 13mm socket.

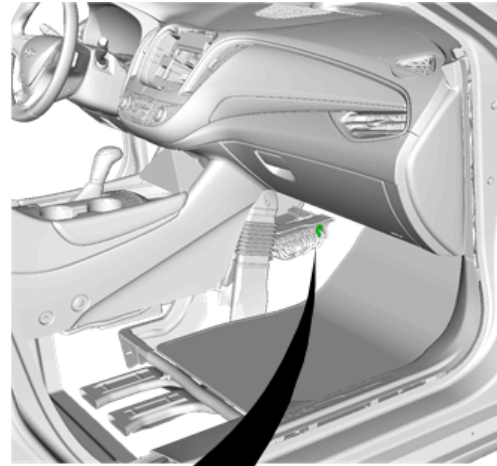
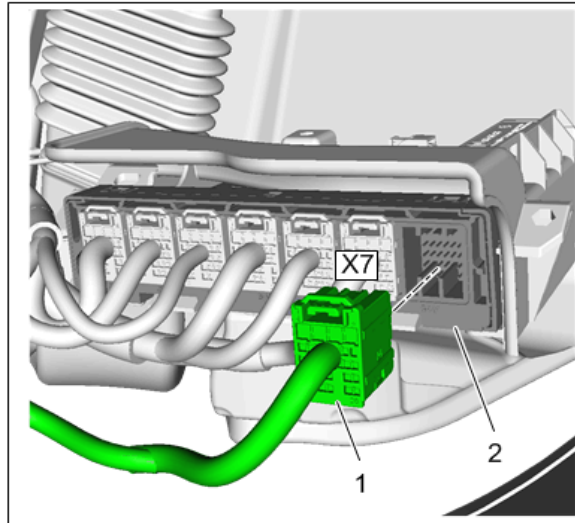

10. Locate the BCM (2) on the front side of the console, under the I/P. Disconnect BCM connector (1) X7 gray.

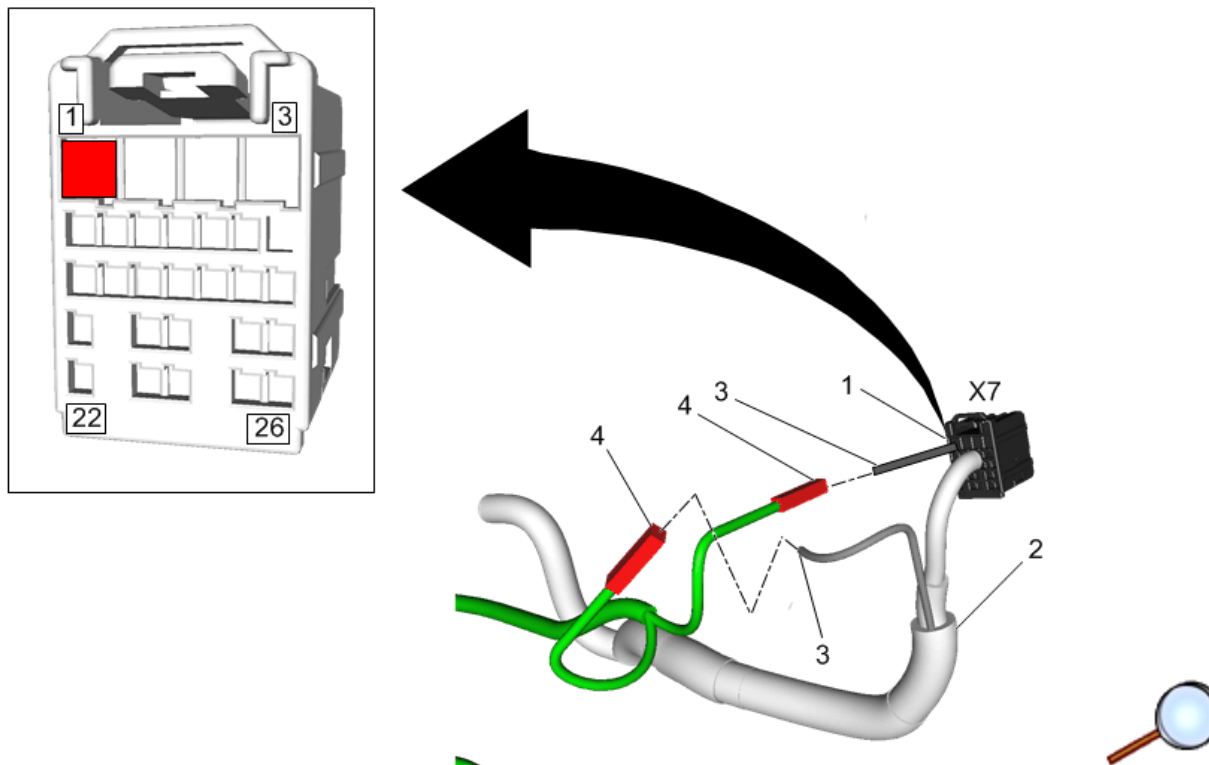

11. Locate cavity #1 on the on the removed connector (1). Remove wire harness covering (2) starting from connector for approximately 4".
12. Gently separate the wire (3) leading to cavity #1 from the rest of wire bundle.
13. Approximately 50 mm from the rear of the connector cut the wire (3) leading to cavity #1.
14. On the supplied wire harness locate 2 blunt (unterminated) ends routed near BCM. Using recommended service technique and the supplied crimp splices (4) splice 1 blunt end to each side of the cut wire.
15. Seal splices and re-tape harness to within 25 mm of rear of connector.
16. Plug in the wire harness connector to the illuminated sill plate wire harness. Do not fully seat the illuminated sill plates at this time.

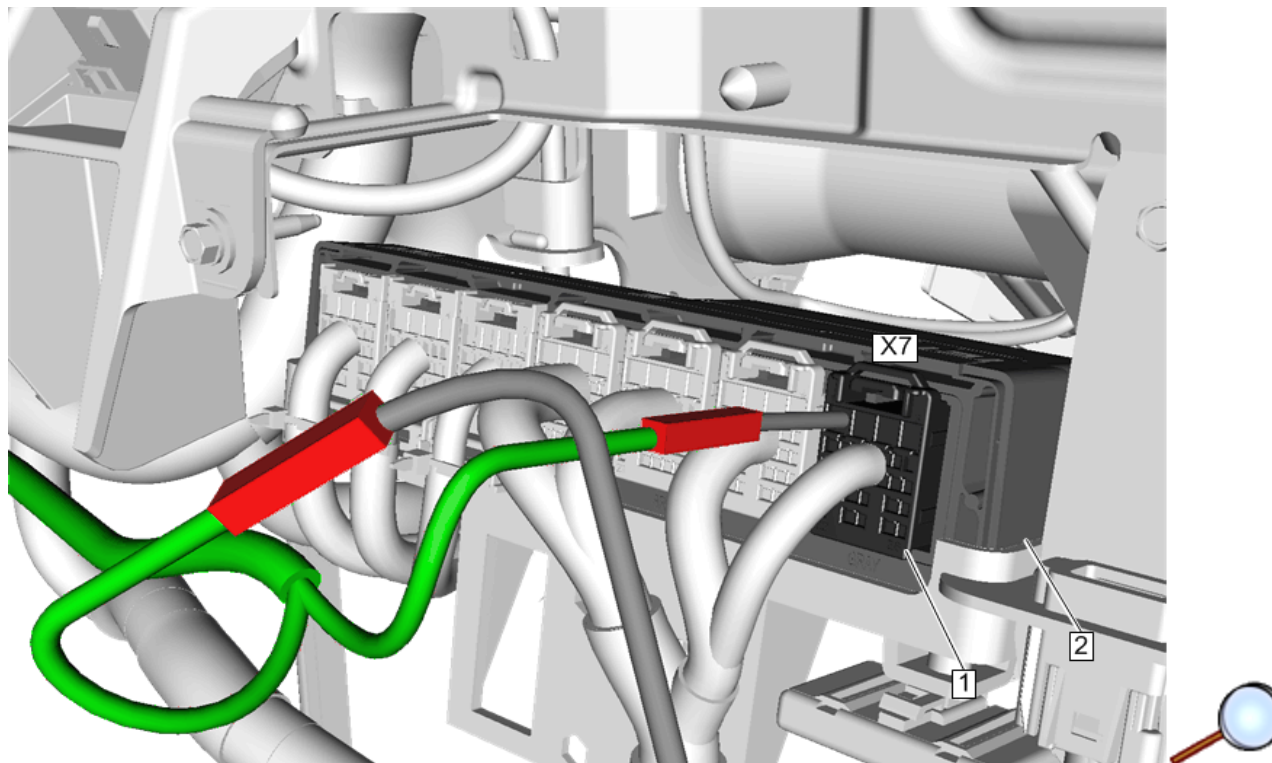

17. Re-connect connector X7 (1) to the BCM (2).

Check Operation of the Illuminated Sill Plates

Verify Illuminate Sill Plate Operation

- Verify all disconnected electrical connections are re-connected.
- Close all doors
- Open each door, door sill will illuminate when the dome light illuminates.
- The door sill plates should light up and go out with dome lamp (make sure dome lamp is on).
- If the sill plates do not light up, check the ground and BCM splice as well as other connections at illuminated door sills, (make sure dome lamp switch is not in defeat position).
- Check to see if the courtesy lights are working.
- Verify that the sill plates are operating correctly.

Complete the Wire Harness Routing

1. Pull back the carpet and route the harness along the floor about 50 to 75 mm below the top of the carpet, from side to side.

2. Use tie straps, as required, to keep harness secure and from being seen. 8 tie straps are provided in the harness package.

Fully Install Illuminated Sill Plates

Note: The illuminated sill plates can be installed on either side of the vehicle.

1. Align the illuminated sill plate snap features to the holes on the rocker panel.
2. Firmly press into place until the sill plate is fully seated.
3. Route the pigtail wiring toward the front of the vehicle.
4. Repeat for the second illuminated sill plate on the opposite side of the vehicle.

Re-install Carpet and Trim

1. Check clips on removed trim panels, replace clips if necessary.
2. Tuck wire harness behind carpet and trim.
3. Reposition carpet, and reinstall removed trim panels.

Note: Verify all wires are neatly secured, pinched and not visible, tie straps should be used as necessary to keep harness secured and out of sight.