

Front Fender Mud Flap Package Installation

Installation Instructions Part Number

23294778

Note: Please read instructions thoroughly before starting.

Front Fender Mud Flap Kit Contents

Qty	Description
1	Left Hand Splash Guard
1	Right Hand Splash Guard
6	Rivet
8	M4.2 x 25 Screw
4	M4.2 U-nut
1	Instruction Sheet

Tools Required

- T15 Screw Driver
- Drill
- 13/64" (5.0mm) Drill Bit
- Clean Cloth/Rag
- Isopropyl Alcohol

Installation Procedure

Note: Do not use power tools to install fasteners.

1. Turn front wheel/tire to provide clearance.
2. Clean and degrease body panel where splash guards will be located.
3. Using isopropyl alcohol, clean area where tape will contact body panel.

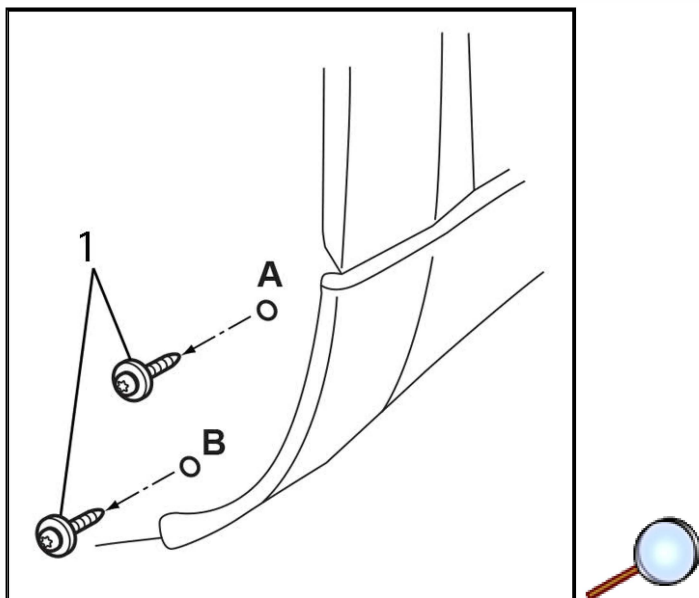

4. Remove existing screws (1) from locations (A) and (B) and discard.

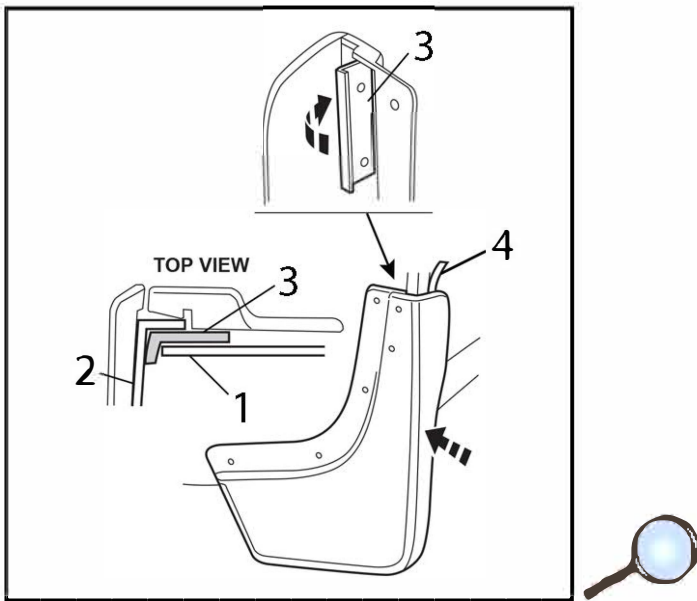

5. Place splash guard assembly to vehicle, make sure red tape pull tab (4) is accessible, and fold living hinge (3) so that it is folded behind fender flange (2). The splash guard and living hinge (3) should "sandwich" around the fender flange (2) and liner (1).

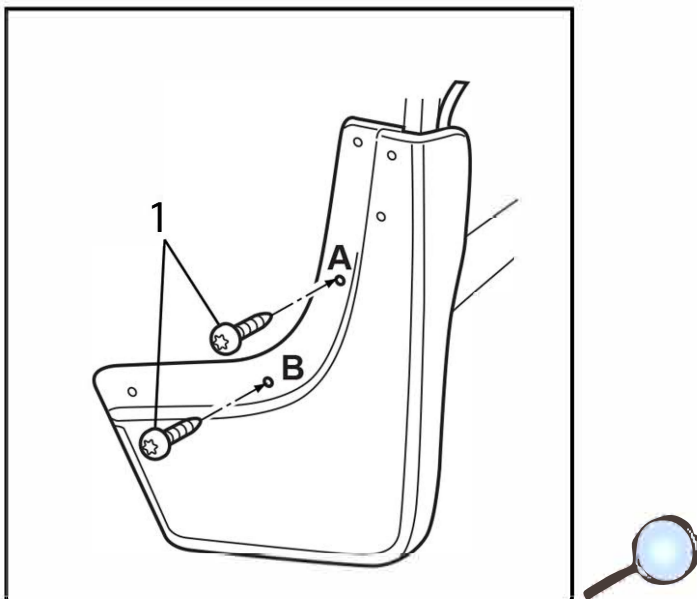

Caution: Use the correct fastener in the correct location. Replacement fasteners must be the correct part number for that application. Fasteners requiring replacement or fasteners requiring the use of thread locking compound or sealant are identified in the service procedure. Do not use paints, lubricants, or corrosion inhibitors on fasteners or fastener joint surfaces unless specified. These coatings affect fastener torque and joint clamping force and may damage the fastener. Use the correct tightening sequence and specifications when installing fasteners in order to avoid damage to parts and systems.

6. While holding splash guard assembly to the vehicle to remove any gaps, install supplied screws (1) at locations (A) and (B).

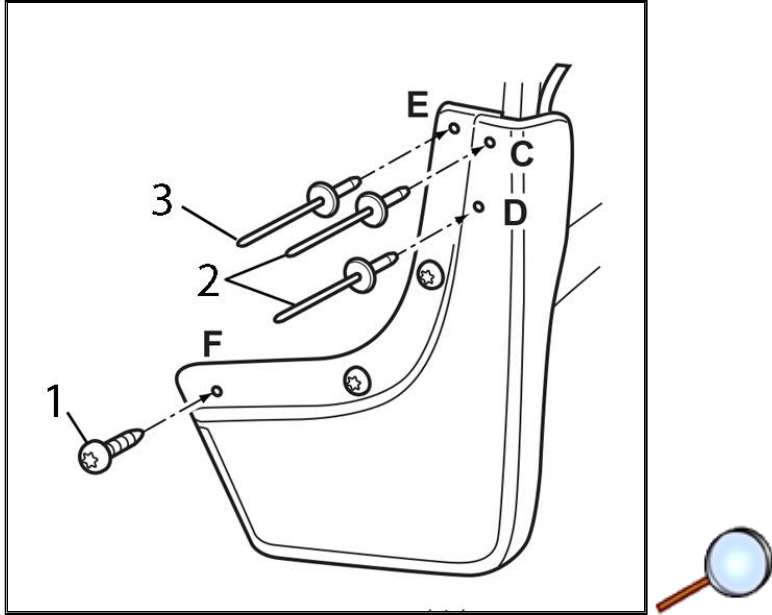

7. Drill 13/64" (5.0 mm) holes at locations (C) and (D). Drill through splash guard, living hinge and wheel liner.
8. Install supplied rivets (2) at locations (C) and (D).
9. Drill 13/64" (5.0 mm) holes at locations (E) and (F). Drill through splash guard and wheel liner.
10. Install supplied rivet (3) at locations (E).
11. Install supplied screw (1) and U-nut at location (F). U-nut should be used as a nut behind wheel liner.

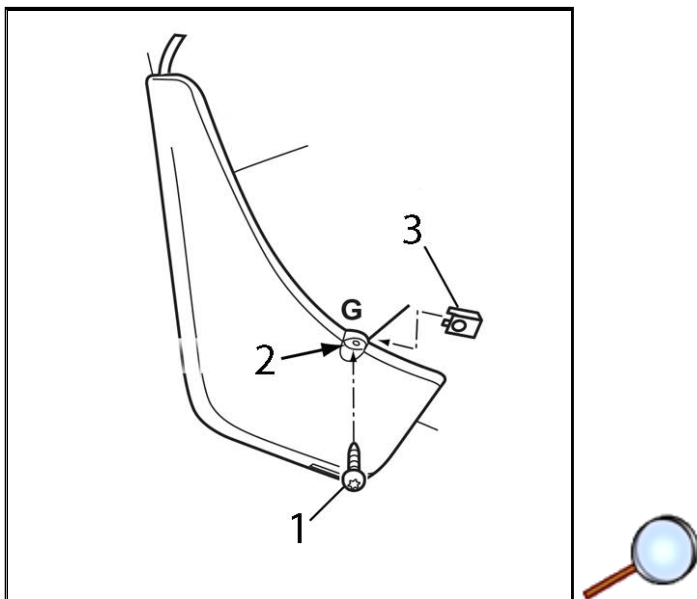

12. While pulling splash guard rearward and inboard to insure no gaps, drill a 13/64" (5.0 mm) hole (2) at location (G). Drill hole through splash guard and rocker.
13. Install supplied screw (1) and U-nut (3) at location (G). U-nut should be used as a nut above the rocker molding.

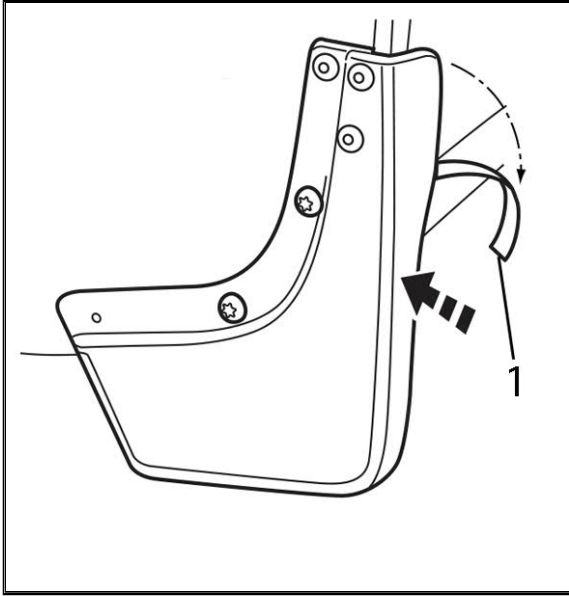

14. Remove tape liner (1) and apply firm pressure to the splash guard along the tape line to adhere the tape to the fender. Hold the firm pressure for a minimum of 60 seconds to properly adhere the tape.
15. Repeat for other side.
16. Guards can be cleaned with any commercially available cleaner.

Note: Maximum torque on M4.2 screw is 3.0 N•m.