

Installation Instructions Part Number

23301629

Kit Contents

Qty	Description
1	Front Bumper Fascia Splitter
12	Front Bumper Fascia Splitter Screws
4	Front Bumper Fascia Splitter Rivets
2	Alcohol Wipes
1	Installation Instructions

Tools Required

Drill, 4mm Drill Bit, Rivet tool

Note:

- Carefully read and understand instructions and components completely before beginning installation.
- Keep the vehicle dry and at room temperature for 24 hours after the installation to allow maximum tape adhesion.
- **CAUTION: FRONT SPLITTER** reduces the vehicle approach angle. Enter driveways and ramps with care.

Procedure

1. Raise and suitably support the vehicle. Refer to Vehicle Service Manual.
2. Make sure the front fascia is at room temperature.
3. Clean the lower portion of the front fascia.

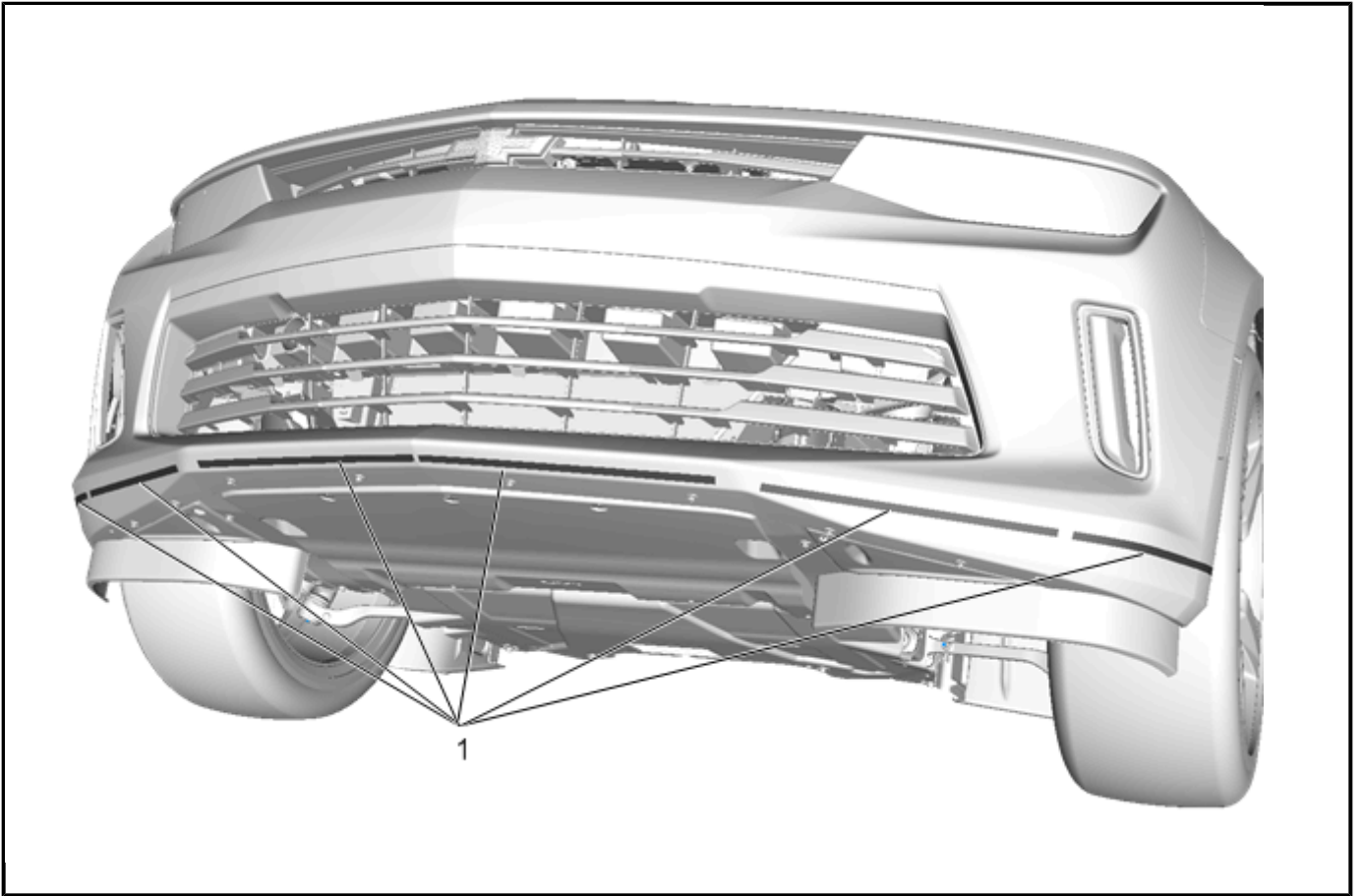

4242555

4. Clean the tape apply area (1) with the provided alcohol wipes.

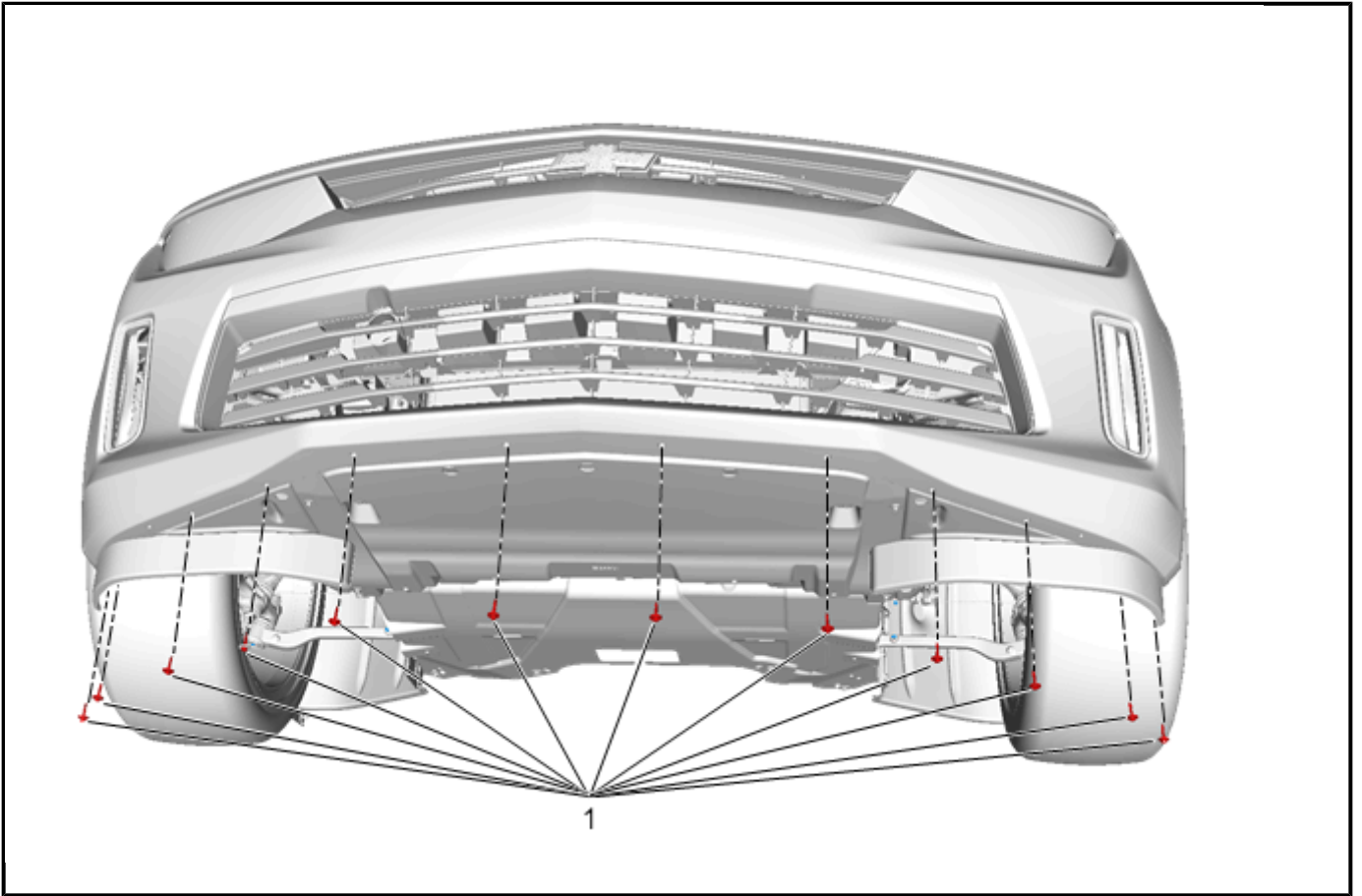

4242557

5. Remove and discard the 12 screws (1) along the front under side of the fascia.

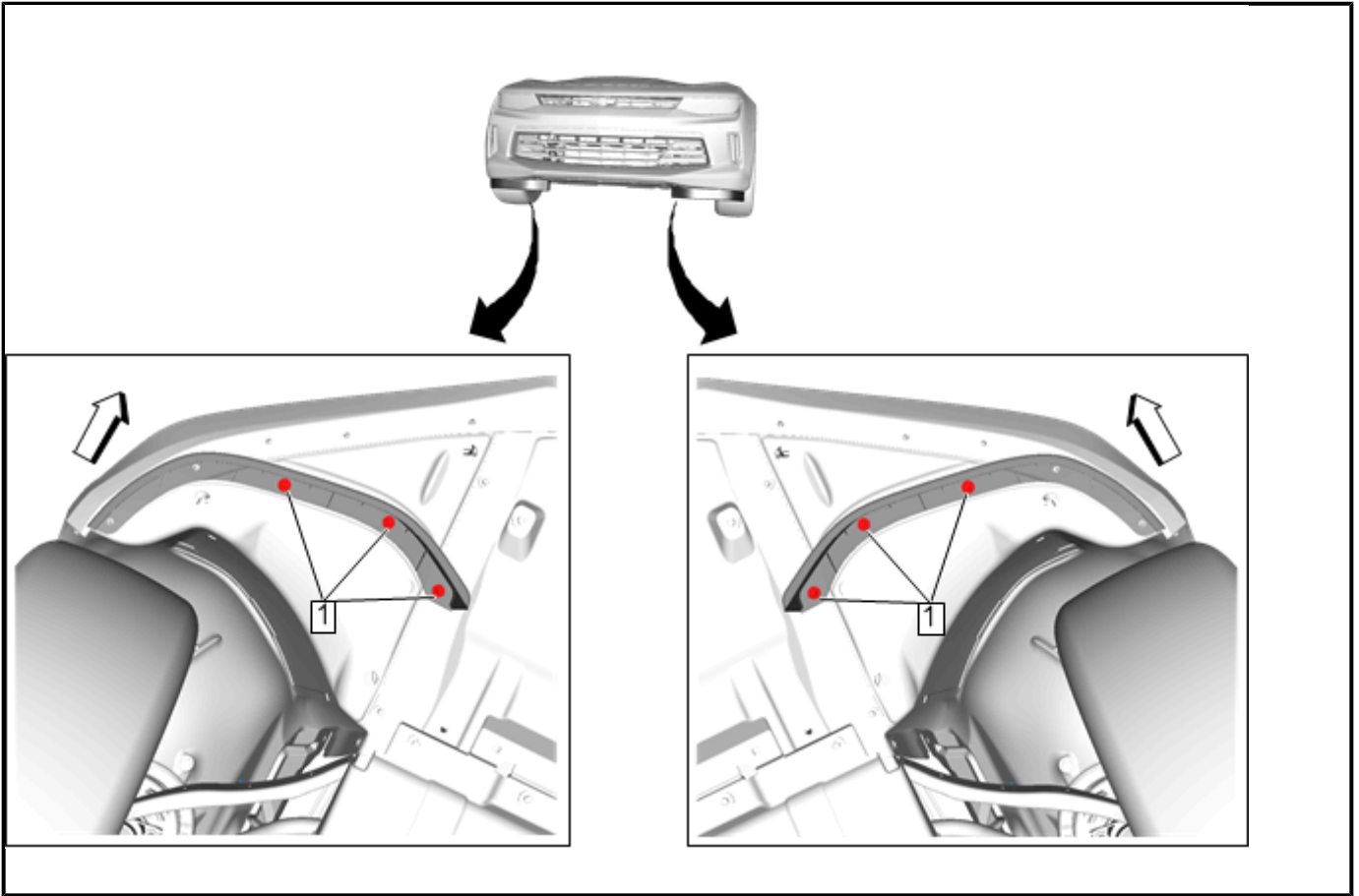

4247297

6. Slightly loosen the remaining air deflector screws (1).

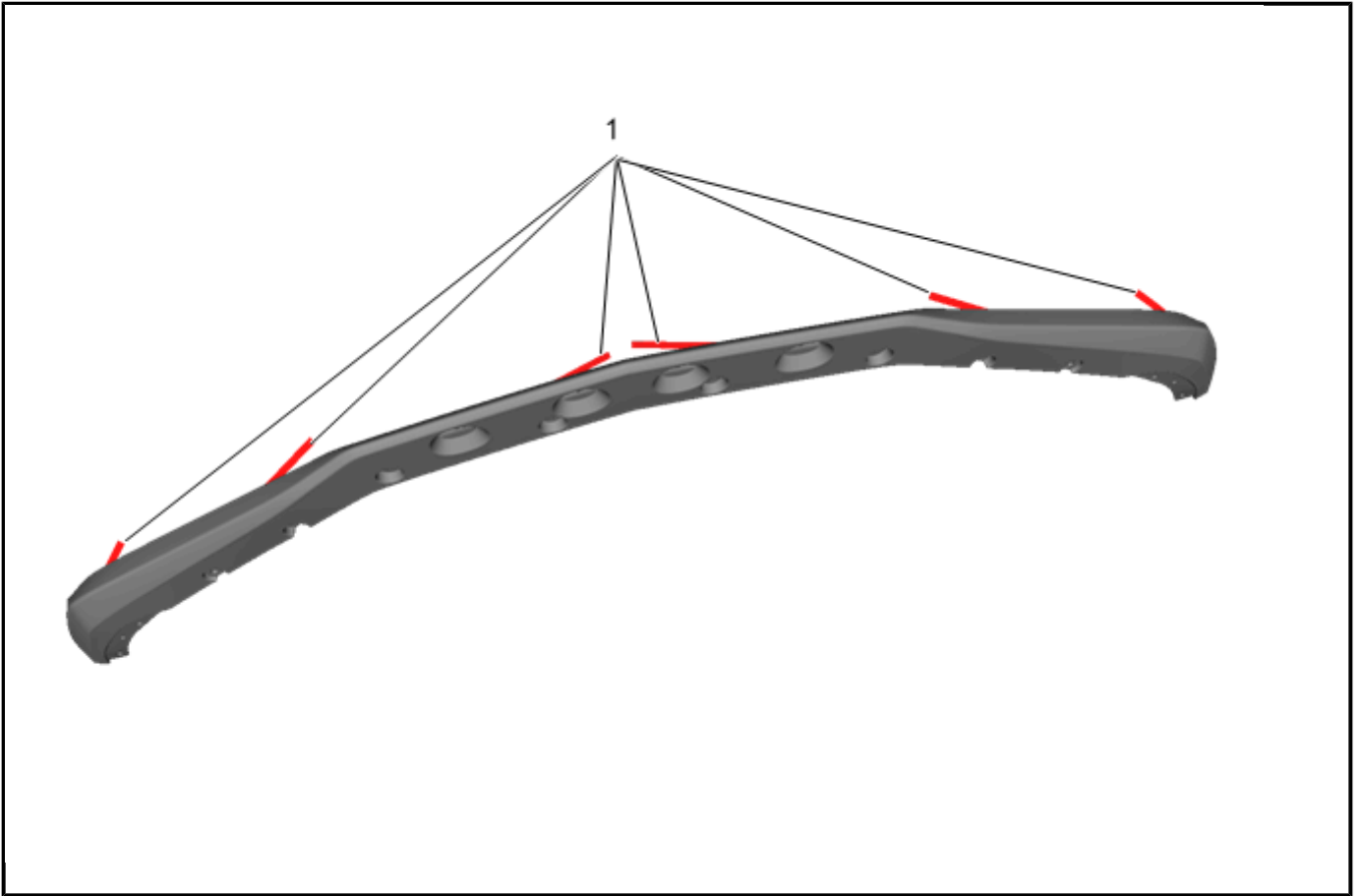

4242560

7. On the front splitter, fold back the ends of the tape backing (1) so they stick out above the top edge.

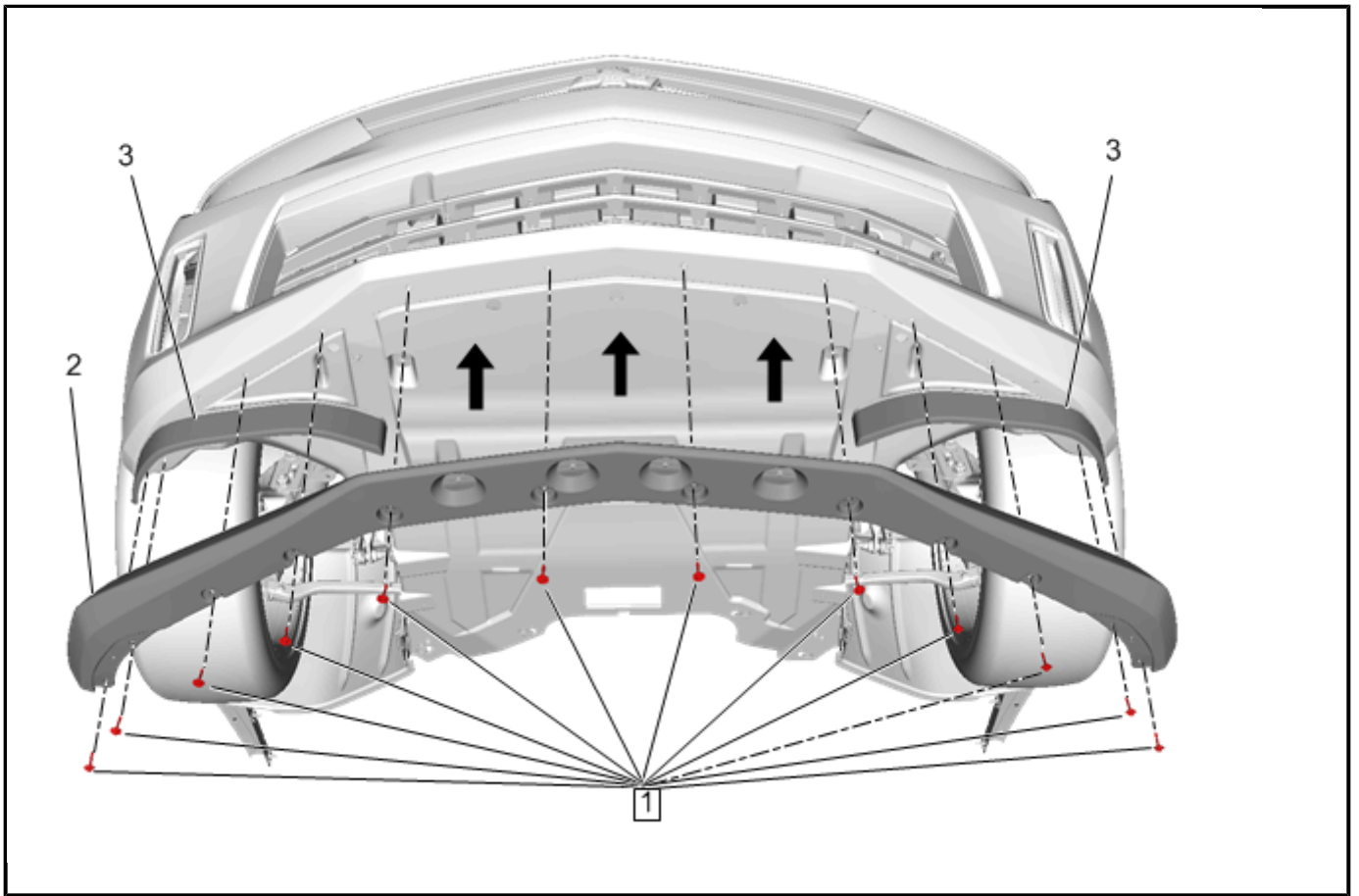

4242562

8. Affix the front splitter (2) loosely to the front fascia using the 12 included screws (1).

Note: The front splitter should lie between the fascia and the LH/RH air deflectors (3).

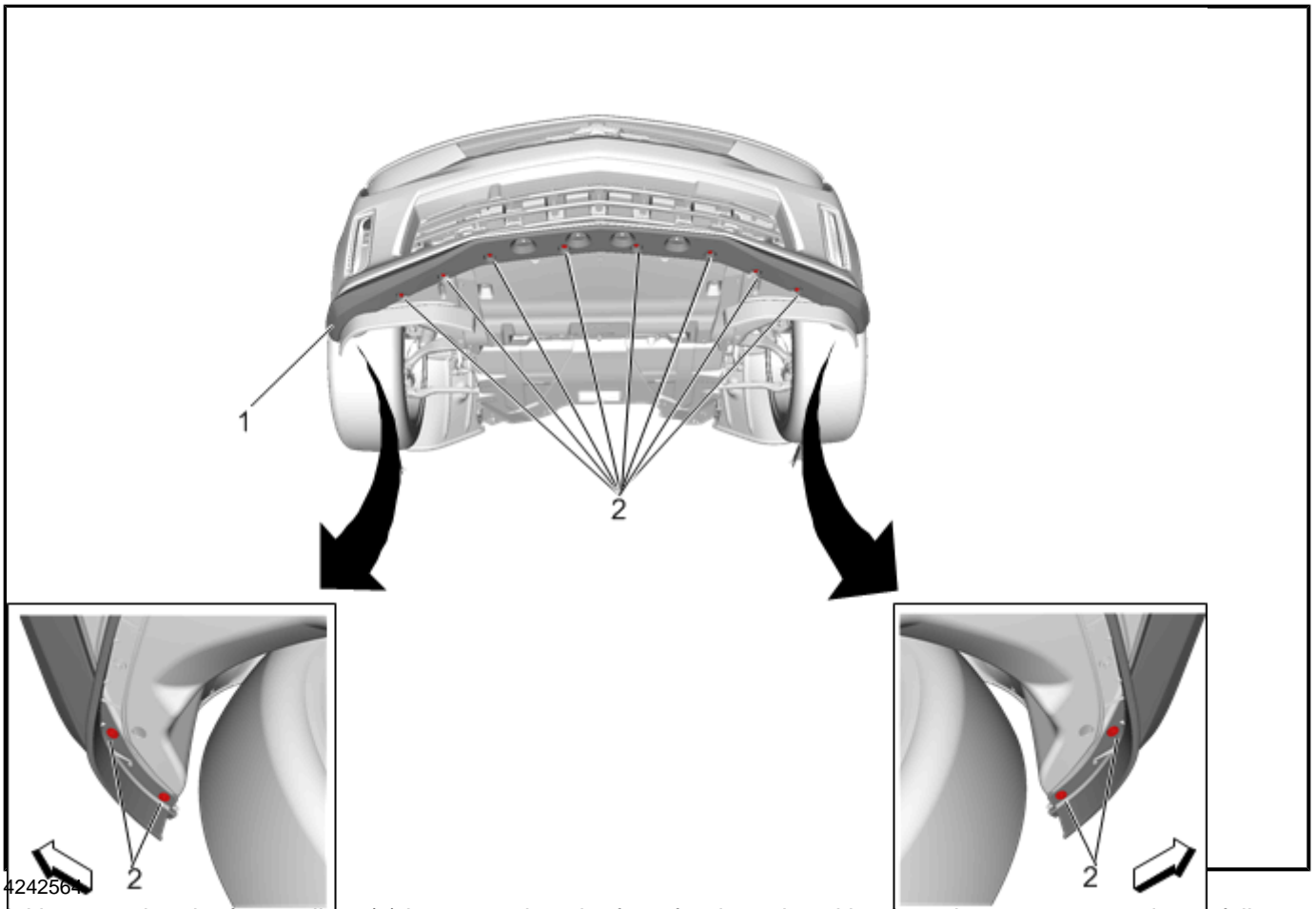

9. Making sure that the front splitter (1) is centered on the front fascia and working from the center outward, carefully remove the backing of the tape strips. Apply strong pressure all along the front splitter to make sure the tape adheres to the fascia.
10. Applying pressure to the front splitter to reduce gaps and working from center outward, tighten the 12 screws (2) that affix the front splitter to the fascia.

Note: Before continuing, inspect the front splitter for proper fit. Adjust and tighten lower screws as needed.

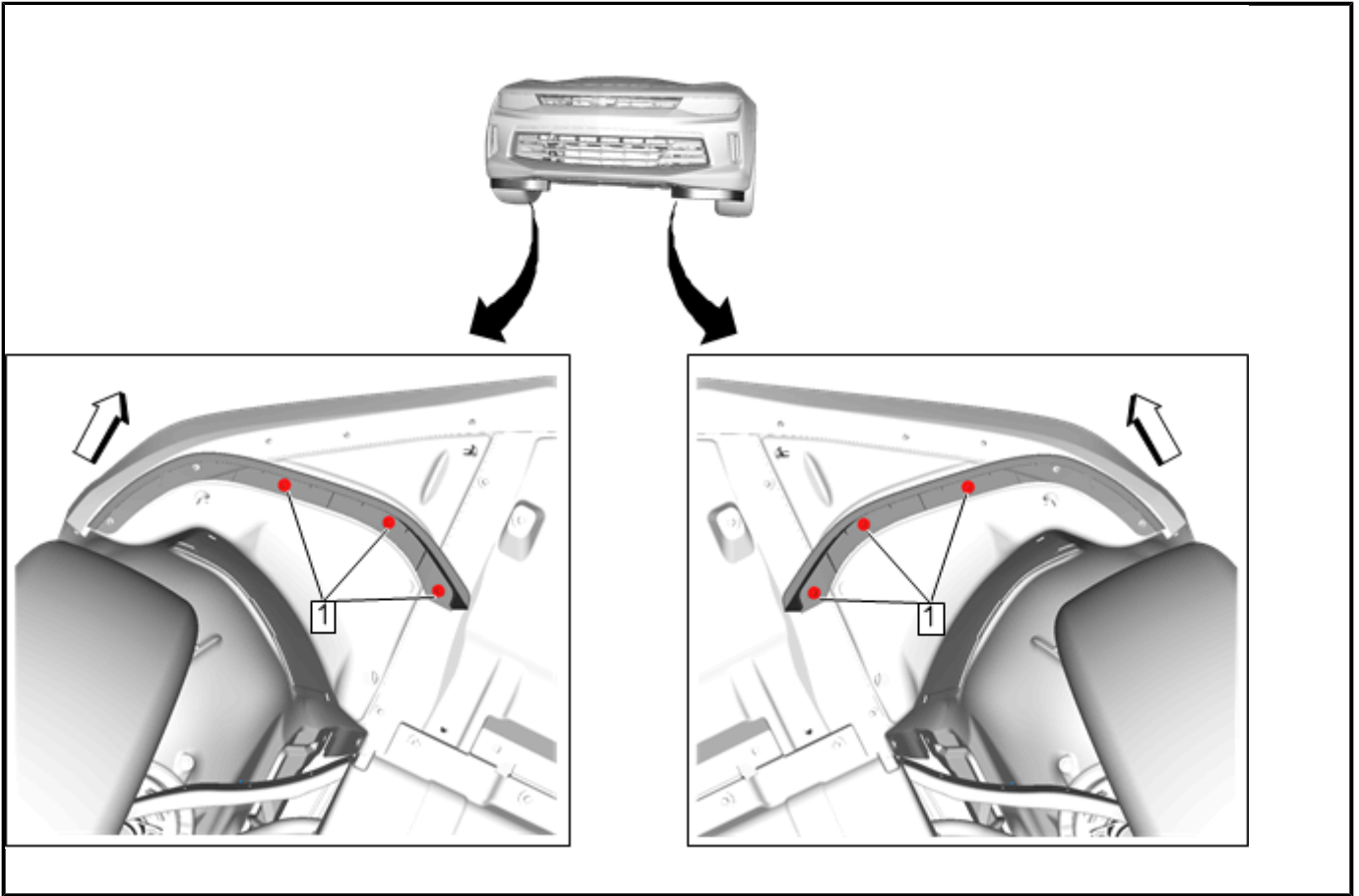

4247297

11. Tighten the remaining air deflector screws (1).

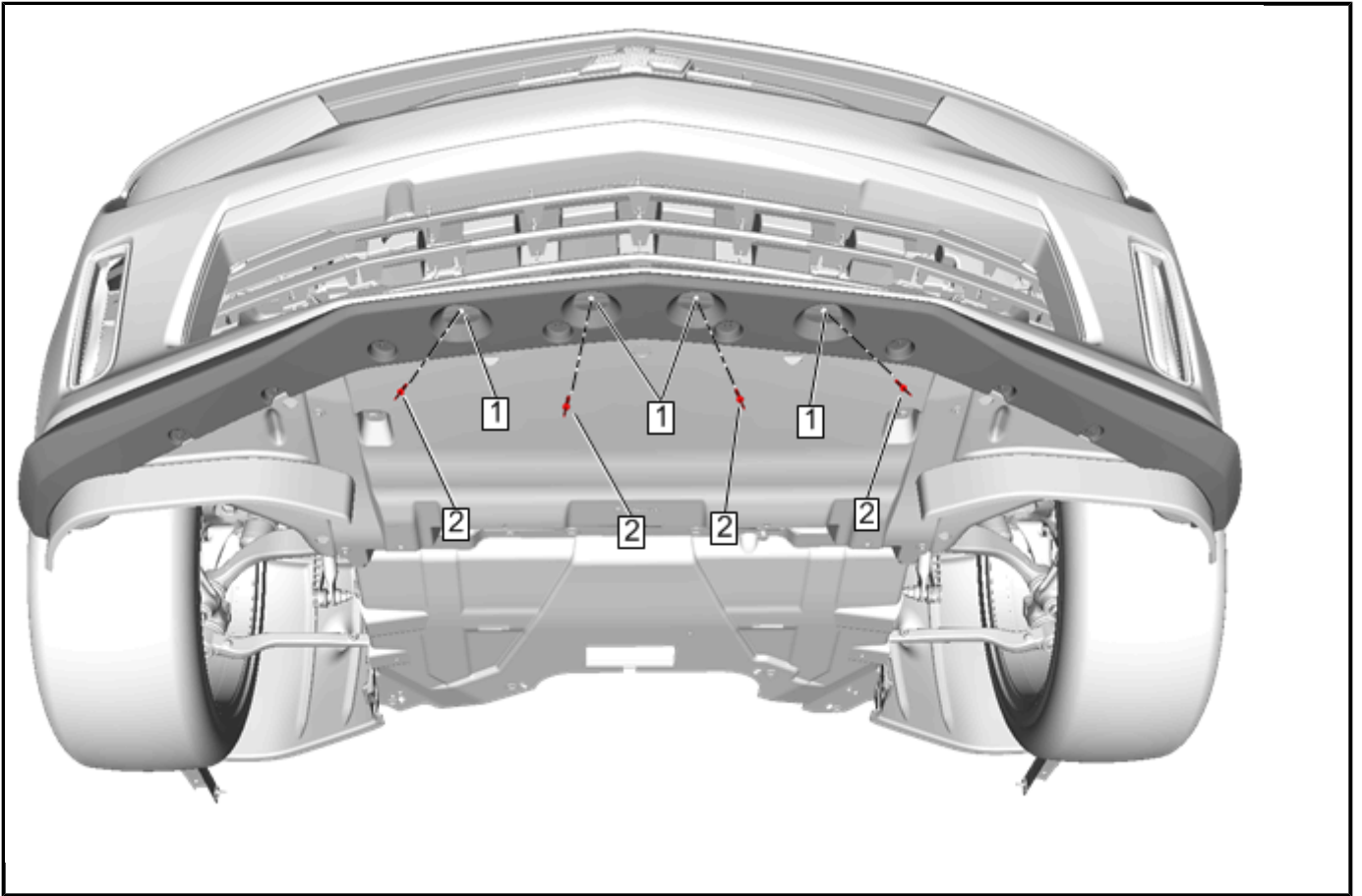

4242566

12. On the underside of the front splitter in the designated areas (1) drill four 4mm holes through the front splitter and into the front fascia.
13. Install the supplied rivets (2) into the drilled holes.
14. Inspect the front splitter for proper install.
15. Lower the vehicle.