

# Front Fender Mud Flap Package Installation

## Installation Instructions Part Number

23354646

**Note:** Please read instructions thoroughly before starting.

### Front Fender Mud Flap Kit Contents

Qty	Description
1	Left Hand Splash Guard
1	Right Hand Splash Guard
1	Left Hand Splash Guard Bracket
1	Right Hand Splash Guard Bracket
6	M4.2 x 20 Screw with Washer
4	M4.2 x 25 Screw
8	M4.2 U-nut (Short)
2	M4.2 U-nut (Long)
1	Instruction Sheet

### Tools Required

- T15 Screw Driver
- Drill
- 1/4" (6.35mm) Drill Bit
- Awl
- Clean Cloth/Rag
- Isopropyl Alcohol

### Installation Procedure

**Note:** Do not use power tools to install fasteners.

1. Remove front wheel and tire. Refer to Vehicle Service Manual.
2. Clean and degrease body panel where splash guards will be located.
3. Using isopropyl alcohol, clean area where tape will contact body panel.

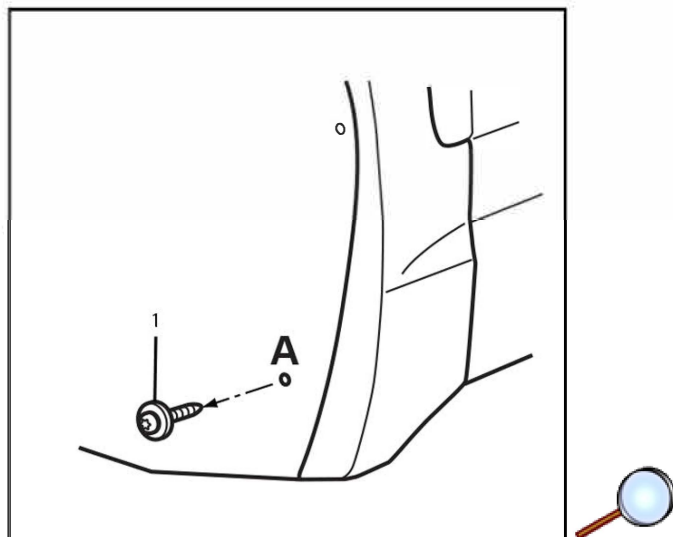

4. Remove existing screw (1) at location (A) and retain.

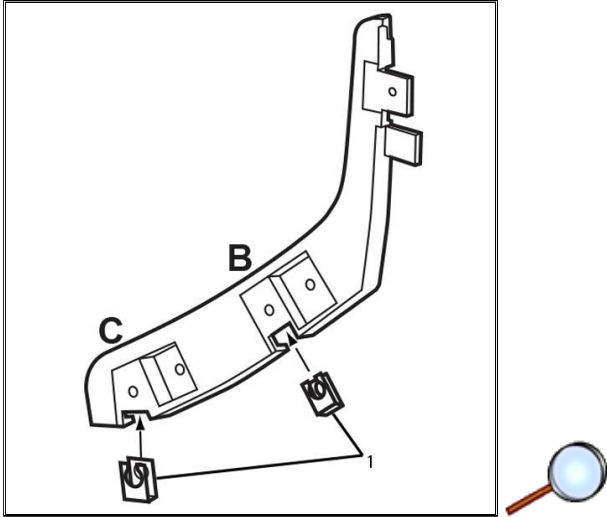

5. Place supplied Short U-nuts (1) onto supplied bracket at locations (B) and (C).

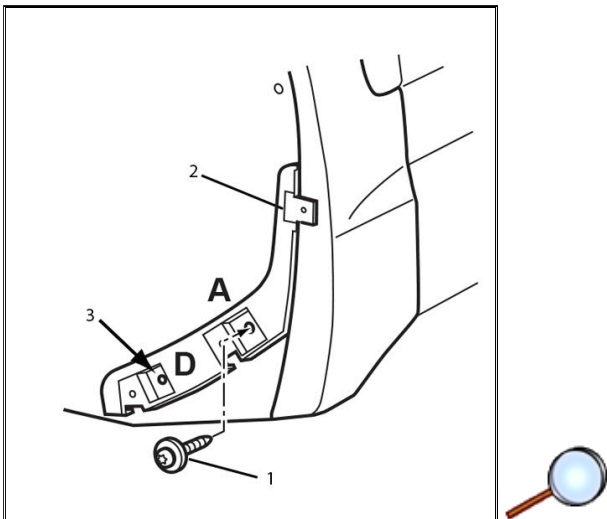

6. Place bracket to vehicle. Partially re-install fastener at location (A), rock bracket against fender cover so that upper tab (2) is visible and lower tab is hidden behind the fender cover and fully tighten screw (1) at location (A).

7. Drill a 1/4" (6.35mm) hole (3) at location (D). Drill through the bracket and wheel liner.

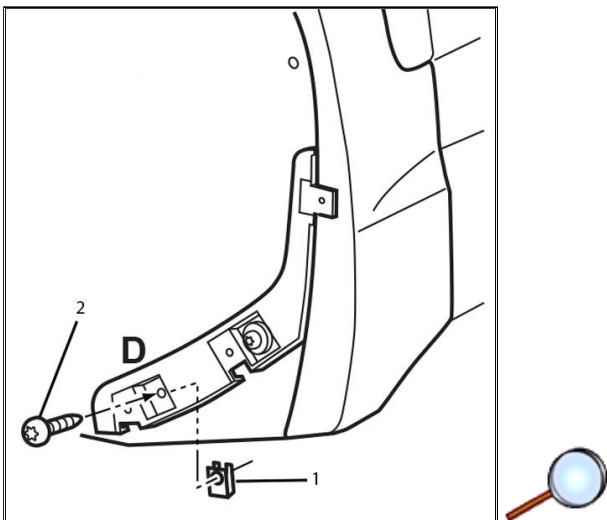

8. Install supplied M4.2 x 25 screw (2) and supplied Short U-nut (1) at location (D). Short U-nut should be used as a nut behind wheel liner.

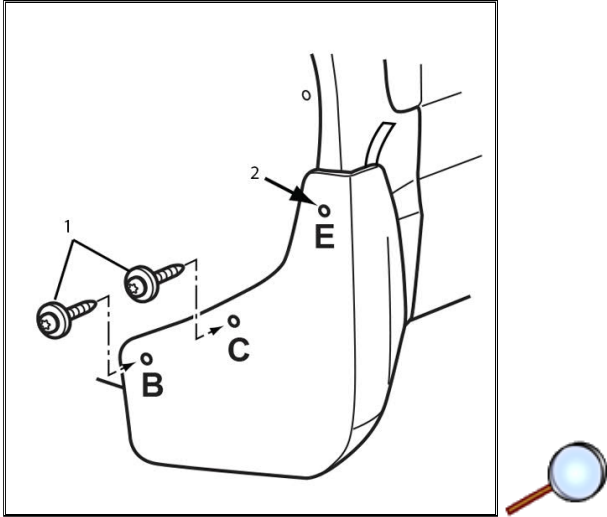

9. While holding splash guard tight to vehicle to eliminate any gaps, place splash guard to bracket and install supplied M4.2 x 20 screws w/washer (1) at locations (B) and (C). Drill 1/4" (6.35mm) hole (2) at location (E). Hole should be drilled through splash guard, bracket and fender cover.

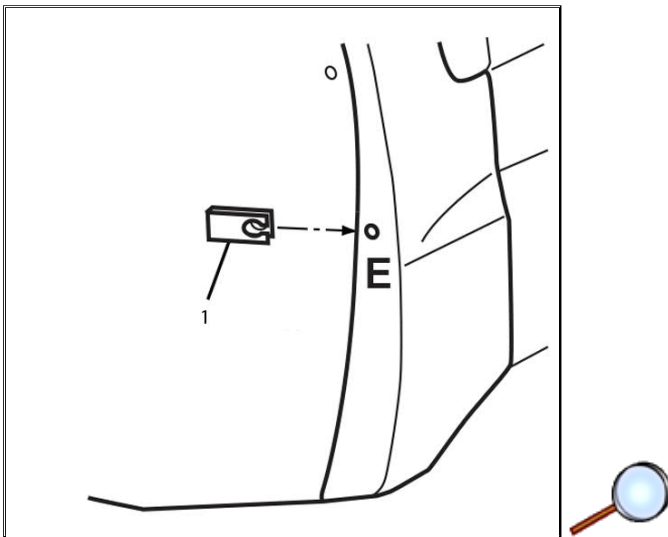

10. Remove splash guard and bracket, install supplied Long U-nut (1) at location (E) onto the fender cover. Using an awl, align Long U-nut with drilled hole opening.

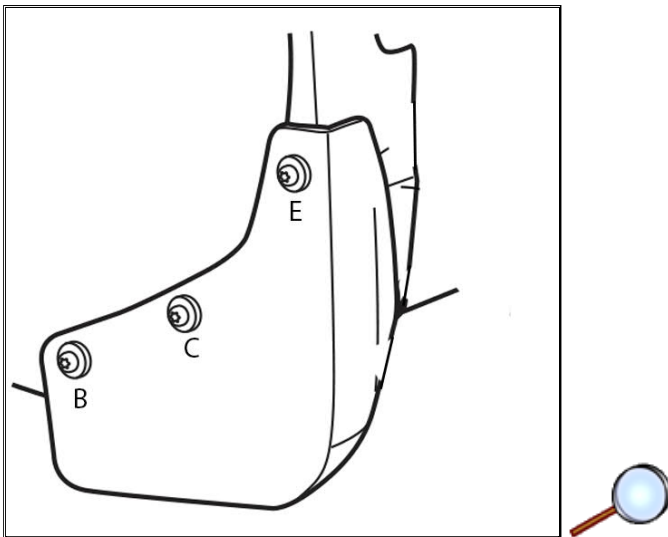

11. Re-install splash guard and bracket by installing fasteners at locations (B), (C) and (E).

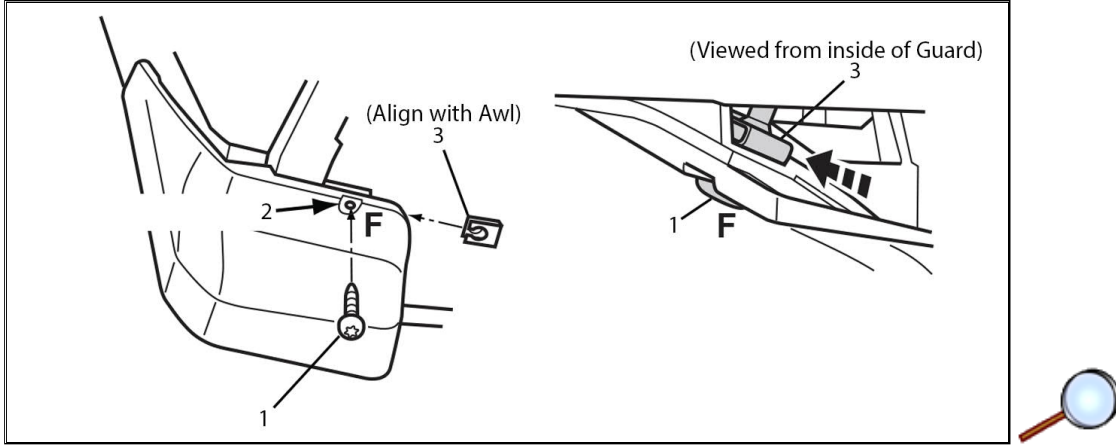

12. While pulling splash guard rearward and inboard, drill a 1/4" (6.35mm) hole (2) through splash guard and rocker molding at location (F).
13. Install supplied M4.2 x 25 screw (1) and Short U-nut (3) at location (F). U-nut should be installed as a nut above rocker molding.

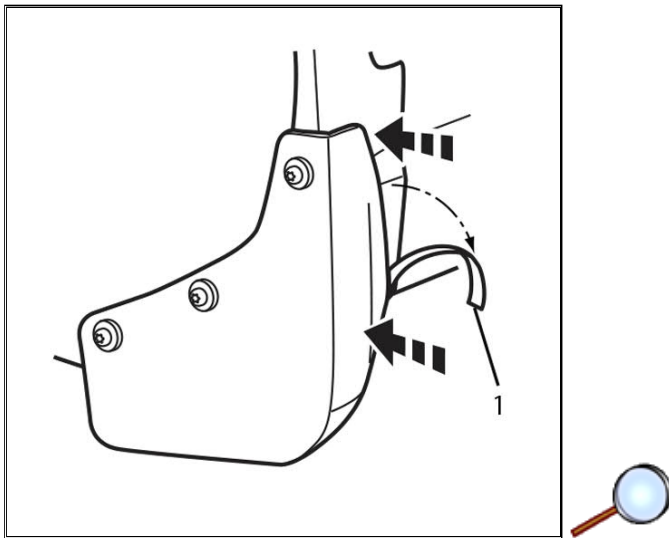

14. Remove red tape liner (1) and use firm pressure along tape area for a minimum of 60 seconds to ensure proper bonding of tape to vehicle.
15. Repeat for other side.
16. Guards can be cleaned with any commercially available cleaner.

**Note:** Maximum torque on M4.2 screw is 3.0 N•m.