

Body Accessory Trim Package Installation

[Installation Instructions Part Number](#)

23433693

Tools Required

Drill, 4mm, 5mm, 7mm Drill Bit, Rivet tool

Note:

- Carefully read and understand instructions and components completely before beginning installation.
- Wash/clean fascias and rockers before ground effects installation.
- Keep the vehicle dry and at room temperature for 24 hours after the installation to allow maximum tape adhesion.
- **CAUTION:** Ground Effects reduces the vehicle's ground clearance. Enter driveways, bumps and ramps with care.

[Procedure](#)

Front Bumper Fascia Splitter

1. Raise and suitably support the vehicle. Refer to Vehicle Service Manual.
2. Make sure the front fascia is at room temperature.
3. Clean the lower portion of the front fascia.

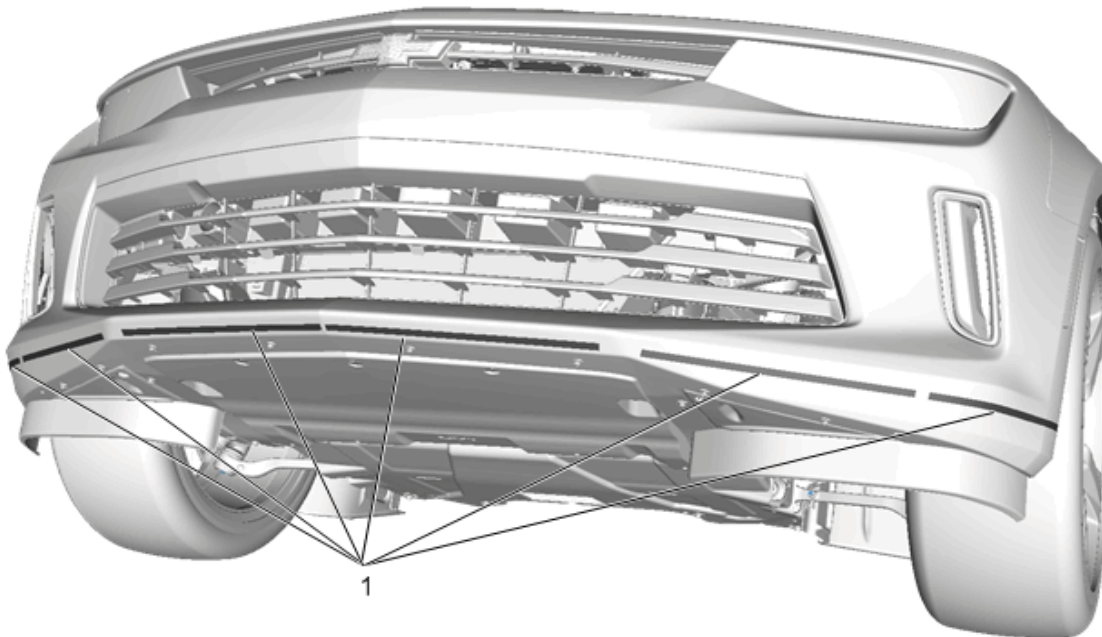

4. Clean the tape apply area (1) with the provided alcohol wipes.

© 2015 General Motors. All rights reserved.

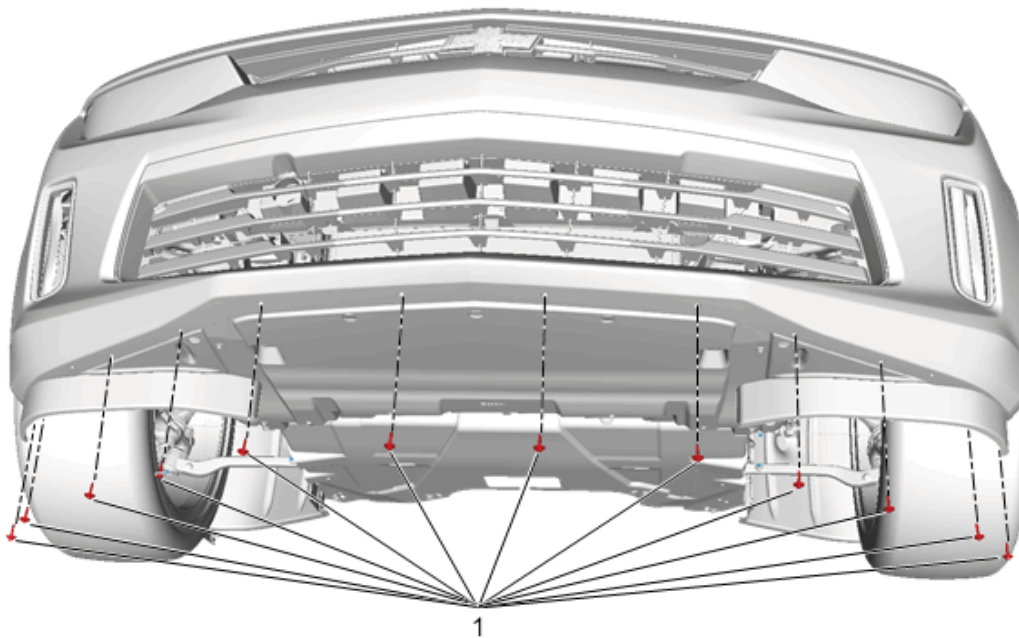

5. Remove and discard the 12 screws (1) along the front under side of the fascia.

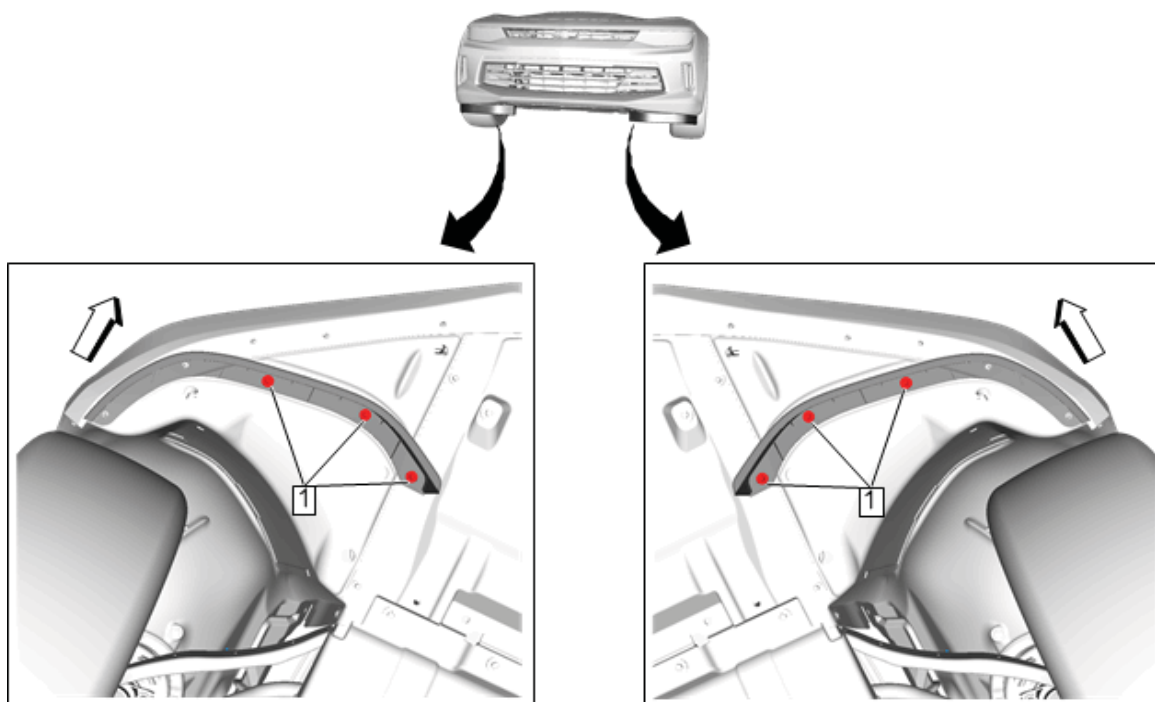

6. Slightly loosen the remaining air deflector screws (1).

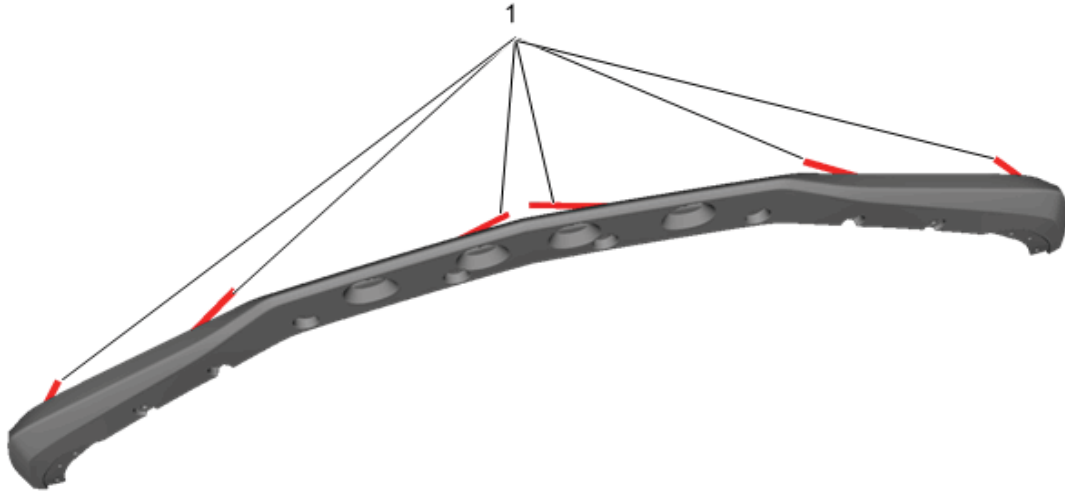

7. On the front splitter, fold back the ends of the tape backing (1) so they stick out above the top edge.

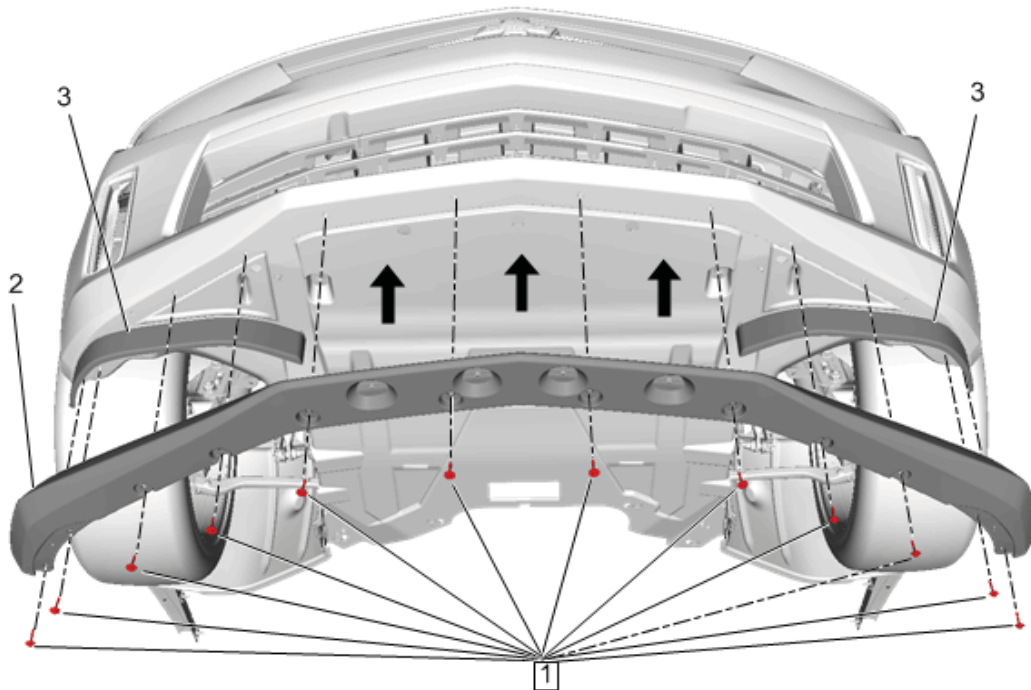

8. Affix the front splitter (2) loosely to the front fascia using the 12 included screws (1).
Note: The front splitter should lie between the fascia and the LH/RH air deflectors (3).

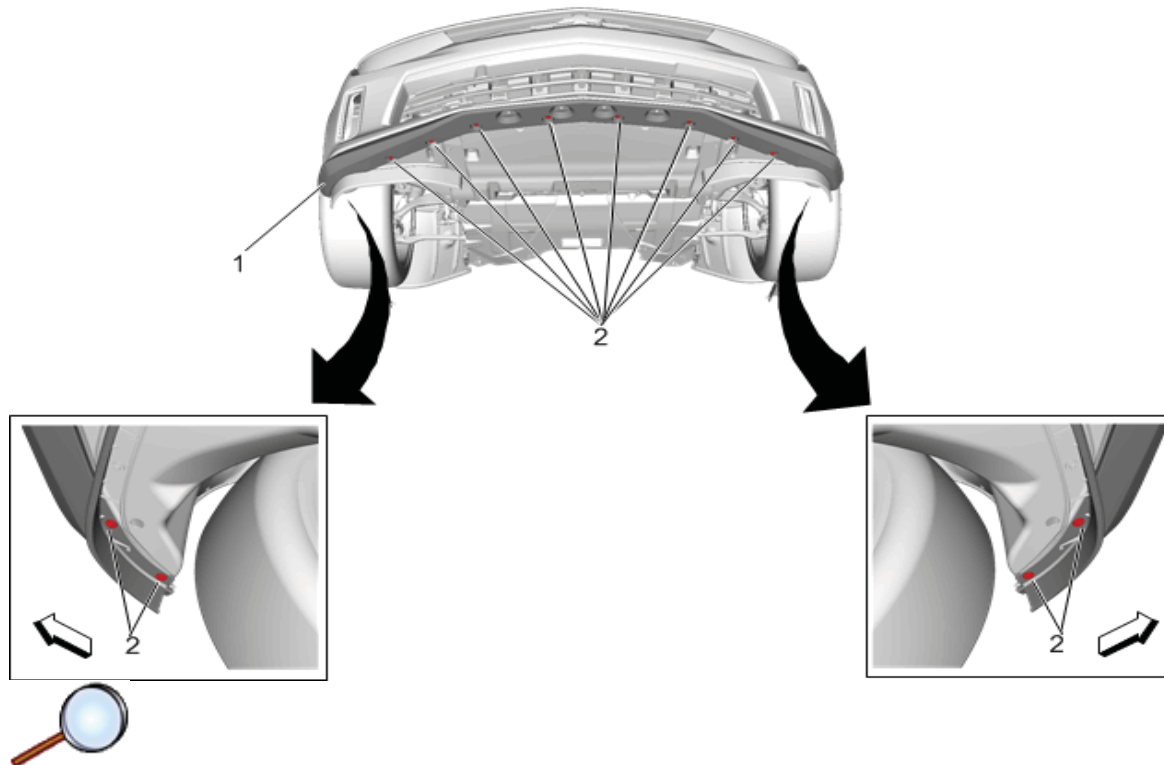

9. Making sure that the front splitter (1) is centered on the front fascia and working from the center outward, carefully remove the backing of the tape strips. Apply strong pressure all along the front splitter to make sure the tape adheres to the fascia.
10. Applying pressure to the front splitter to reduce gaps and working from center outward, tighten the 12 screws (2) that affix the front splitter to the fascia.

Note: Before continuing, inspect the front splitter for proper fit. Adjust and tighten lower screws as needed.

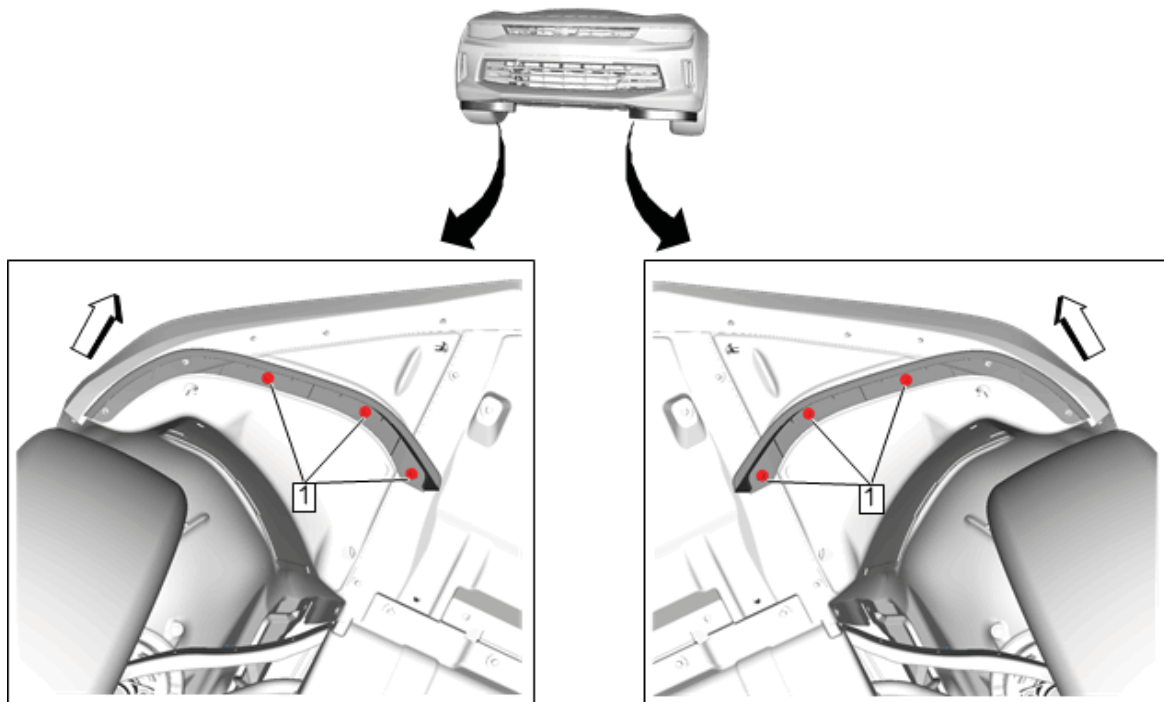

11. Tighten the remaining air deflector screws (1).

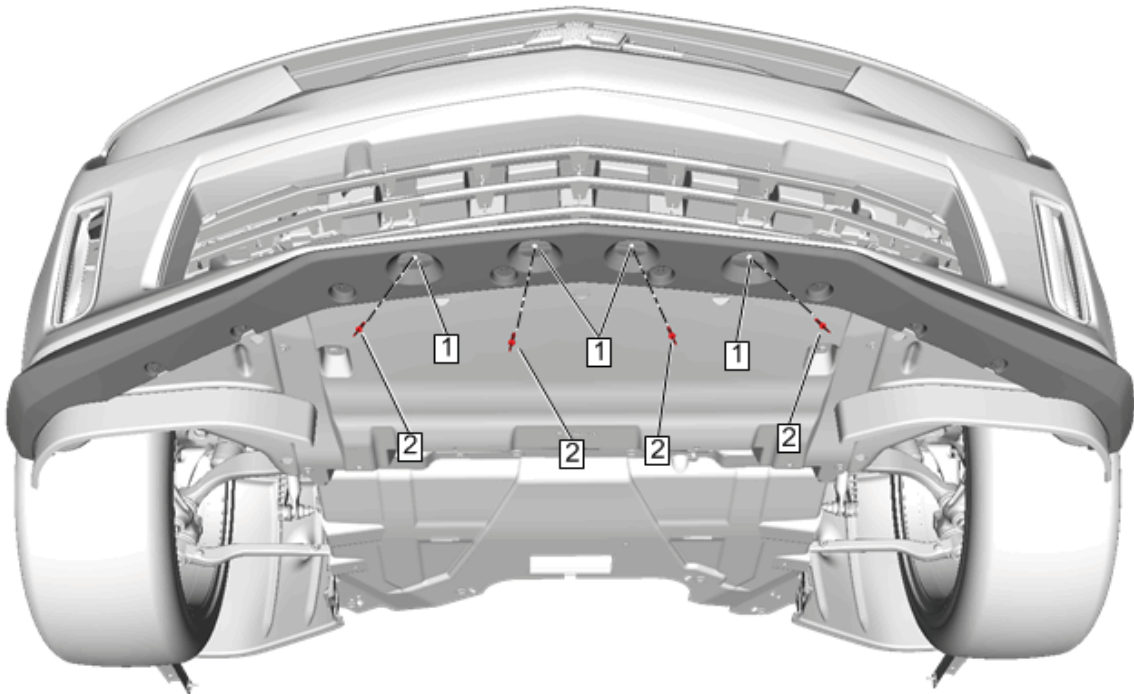

12. On the underside of the front splitter in the designated areas (1) drill four 4mm holes through the front splitter and into the front fascia.
13. Install the supplied rivets (2) into the drilled holes.
14. Inspect the front splitter for proper install.

15. Lower the vehicle.

Rocker Moldings

1. Raise vehicle safely on hoist. Make sure the hoist lift points do not cover the underside of the rocker moldings.
2. Clean the rocker moldings.
3. Open side door to aid in installation.

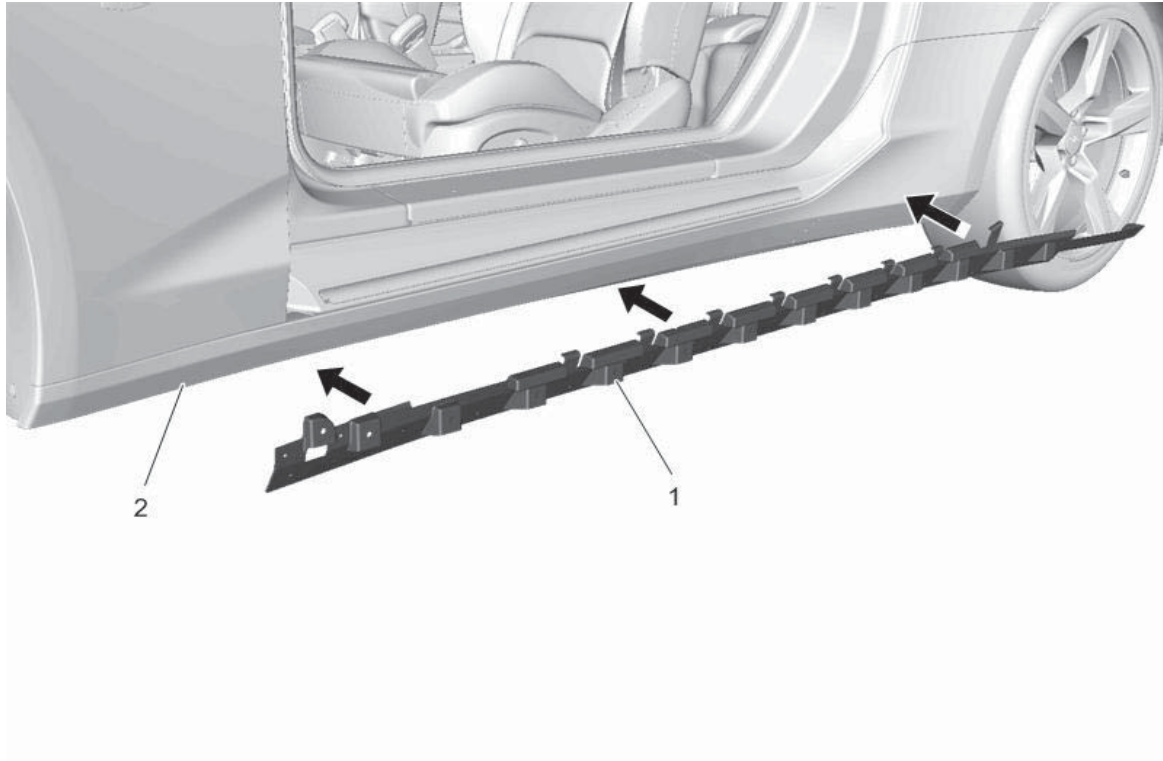

4. Position the mounting bracket (1) to the rocker molding (2).

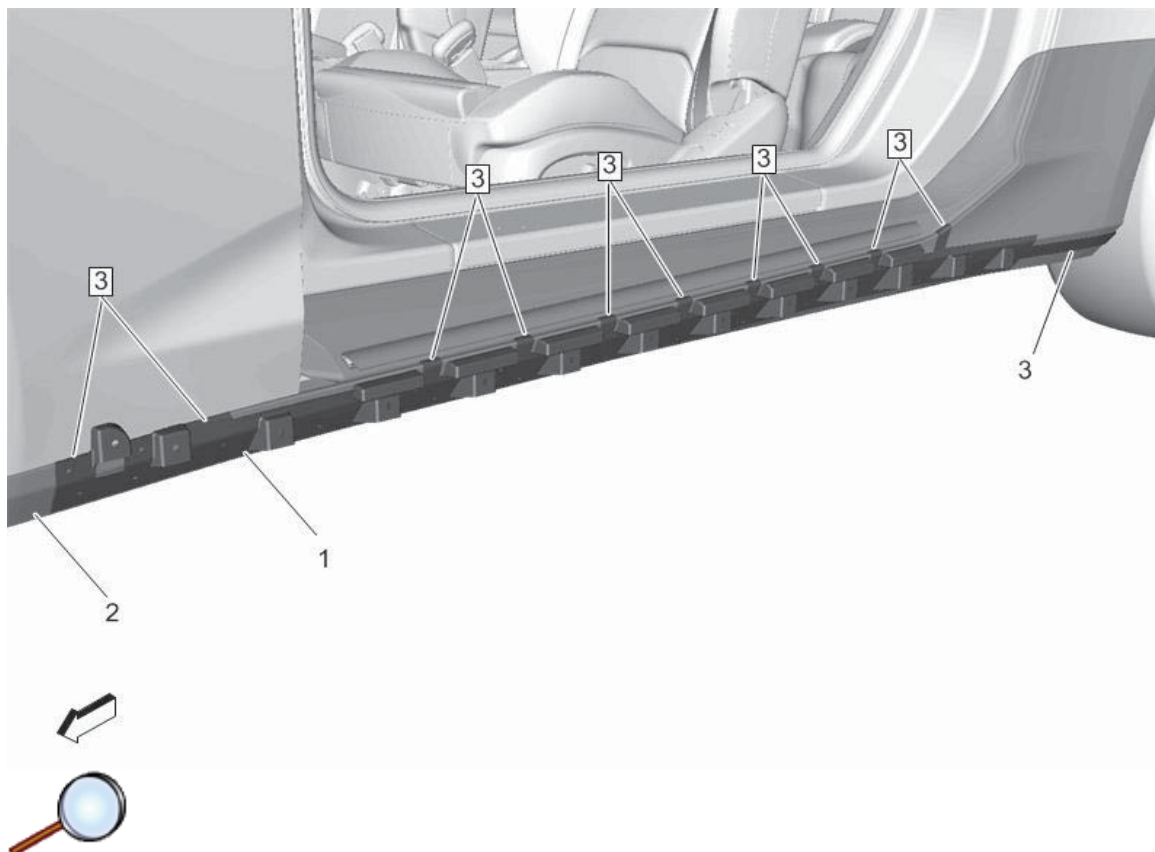

5. Using the temporary locating tabs (3), position the mounting bracket (1) to hang off the door opening. Use the rear locating tab to position the bracket fore-aft. Use the part edge to locate the bracket at the fender gap (2).

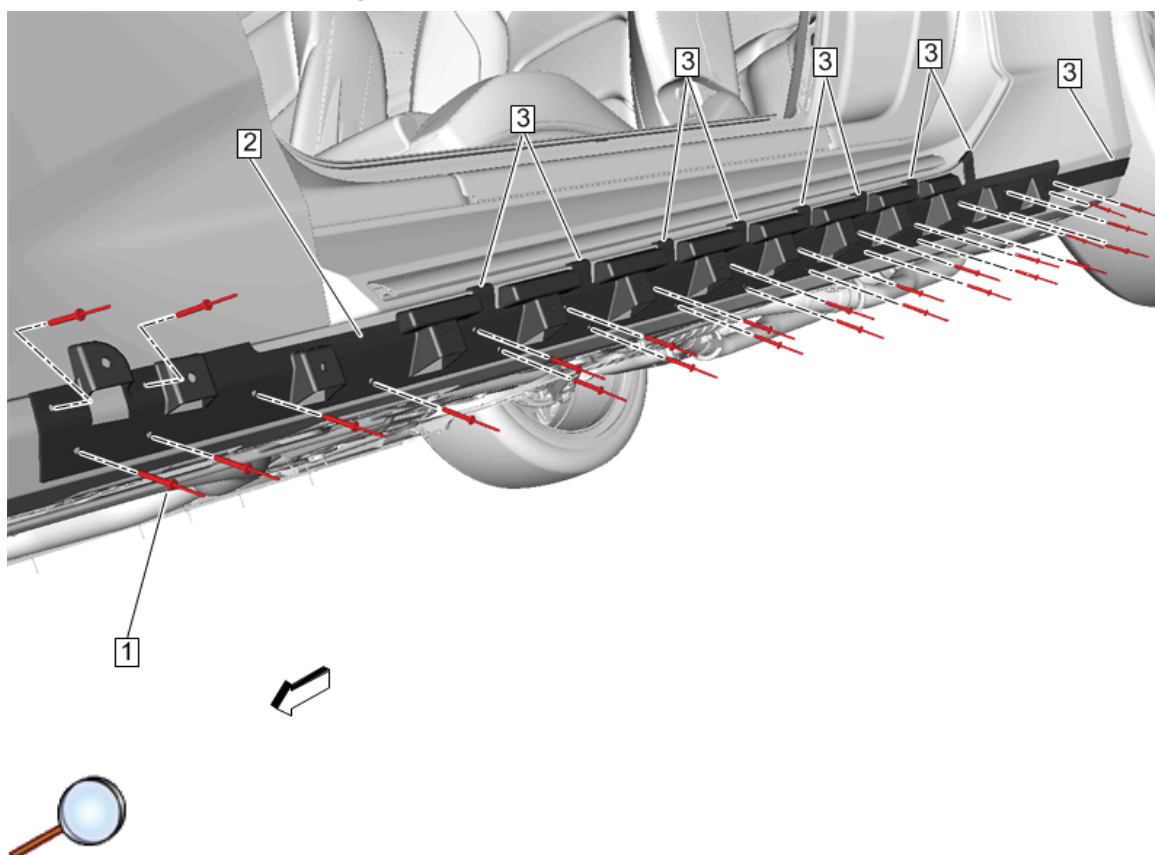

6. Tape the bracket (2) firmly in place.
7. Drill 26 holes in the designated places. Clean off any burrs.

8. Attach the mounting bracket to the existing rocker with the 26 rivets (1).
9. Snap off the locating tabs (3) 8 middle, 1 rear. Remove any tape used to hold on the mounting bracket.
10. Clean fender and rocker with alcohol wipes where tape will adhere.

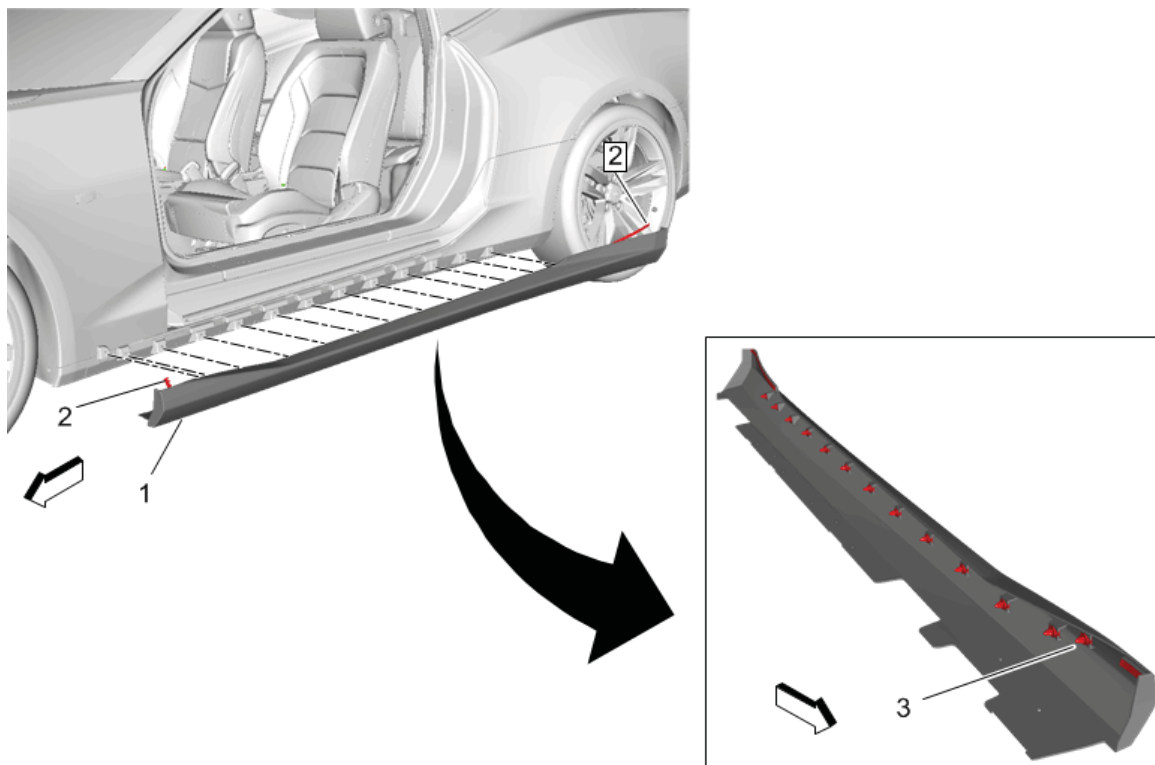

11. On the outer rocker panel (1), make sure the tape backing (2) protrudes past the edge of the part. Make sure that all clips (3) are in place on the back side.
12. Install the rocker outer (1) to the mounting bracket, making sure all clips 'click' into their holes on the bracket.
13. Carefully remove tape backings and apply strong pressure to the fender and rear rocker tape areas to ensure tape adhesion.

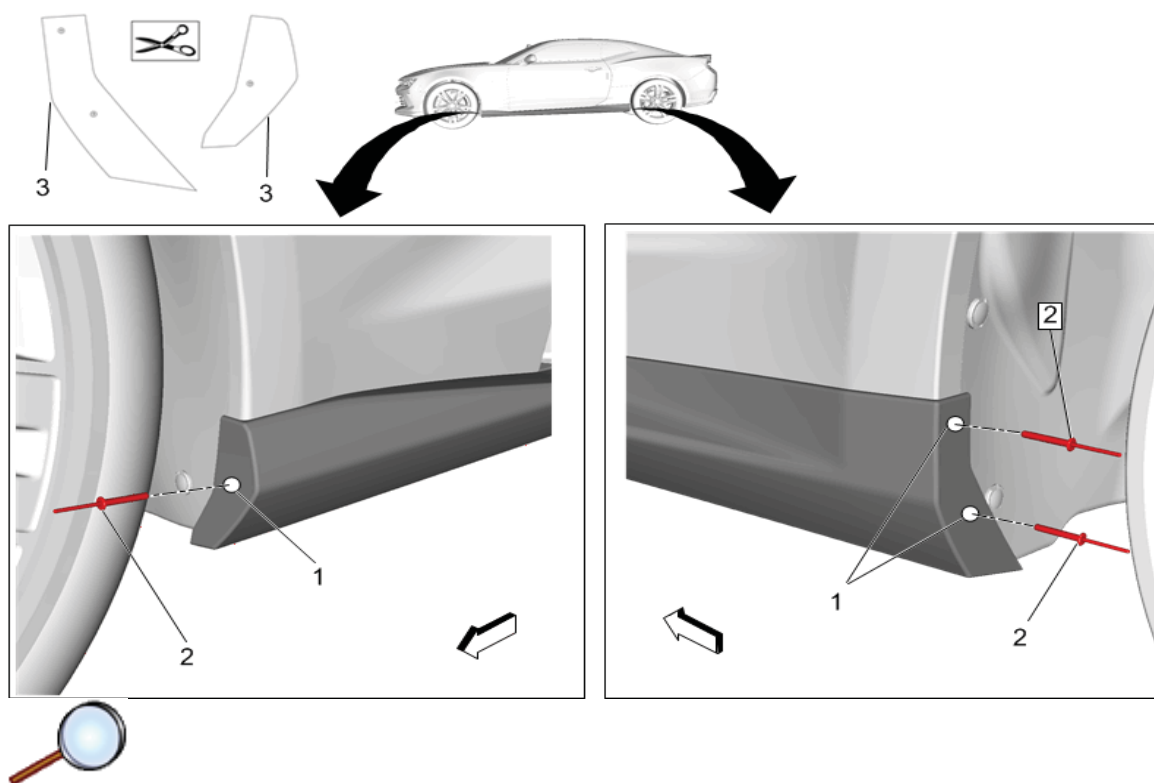

Caution: Always check scale, size and position of all templates before drilling. Failing to do so may cause damage to the vehicle, misalignment of components or the inability to install the accessory.

14. Cut out the supplied paper templates (3) and position them with tape on the front and rear faces of the rocker molding. Making sure the accessory rocker is firmly against the production rocker, drill 5mm holes (1) in the designated areas through the accessory rocker and the production car rocker.
15. Remove the templates and save for use on the opposite side.
16. Install rivets (2) in the front face and the rear face of the rocker molding.

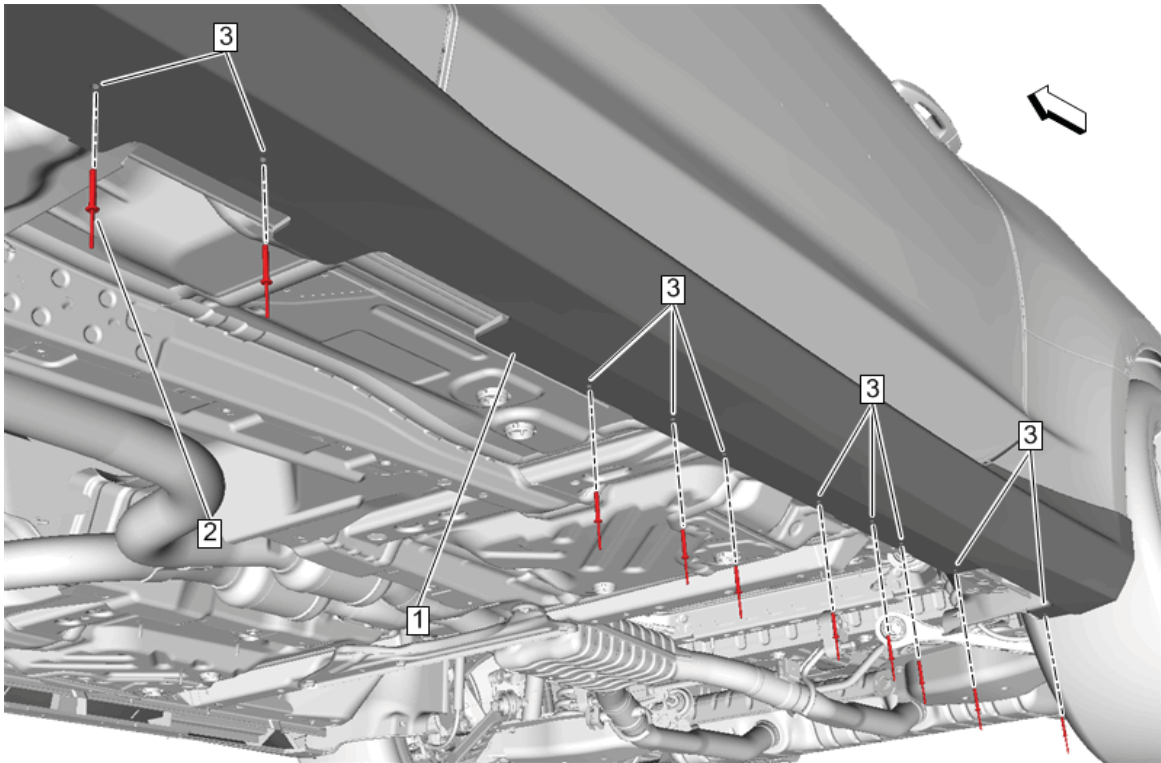

17. Make sure the ROCKER OUTER is fitting properly to the car in all areas.
18. Drill 10 holes (3) along the underside of the ROCKER OUTER (1) in designated areas.
19. Install 10 rivets (2) into the drilled holes.
20. Inspect ROCKER OUTER for proper installation. Apply additional pressure to taped areas as needed.

Rear Fascia

1. Remove the rear bumper fascia. Refer to Vehicle Service Manual.
2. Place the fascia down on a clean, protected work surface to avoid scuffing and scratching.

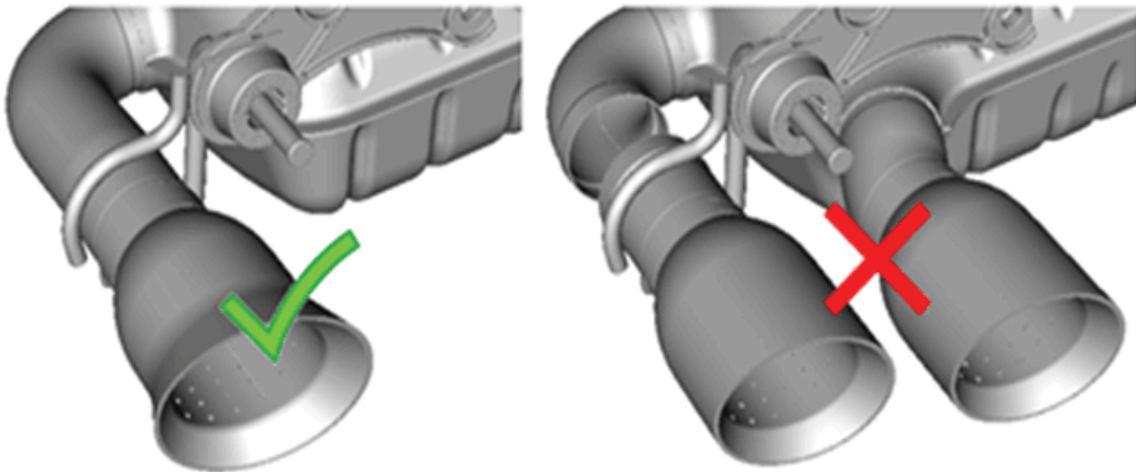

Note: Steps 3 - 6 are for regular DUAL exhaust vehicles ONLY. (1 exhaust tip per side.)

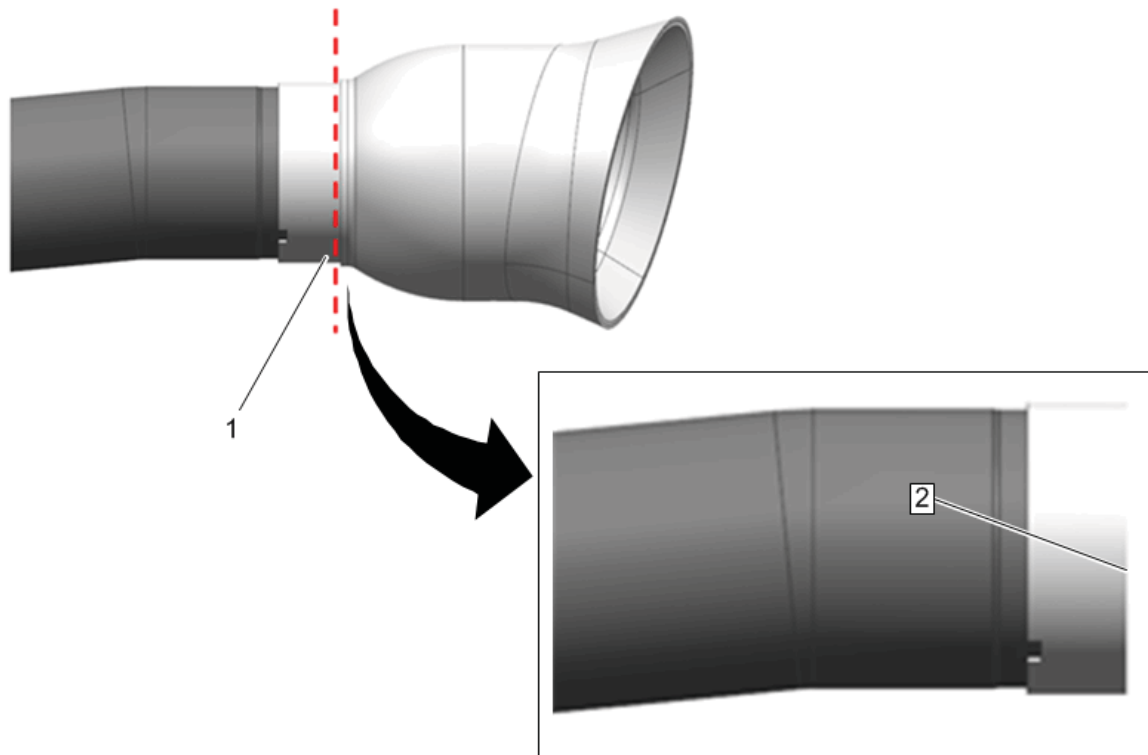

3. Cut through the chrome exhaust tip with a saw at the designated location (1), making sure to leave as much straight length of chrome pipe as possible. Clean and deburr the cut end of the pipe (2).

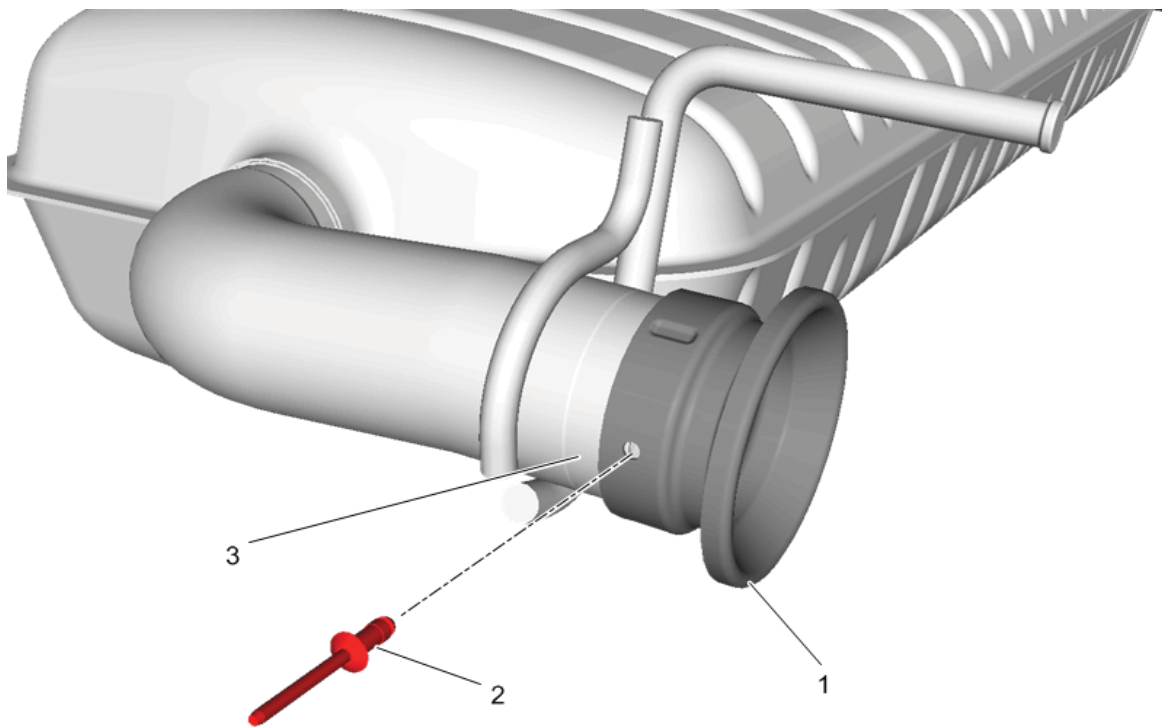

4. Press the EXHAUST RING (1) onto the cut end of the pipe (3). Insert it as far as it will go. Take care not to scratch the black paint on the face of the EXHAUST RING. Make sure the rivet hole is facing outward.

5. Drill a 5mm hole into the exhaust pipe where the exhaust ring hole is. Install provided rivet (2).
6. Repeat steps 2 - 5 for the opposite side.
7. Remove the rear bumper fascia energy absorber. Refer to Vehicle Service Manual.
8. Separate the rear bumper lower fascia from the rear bumper fascia. Refer to Vehicle Service Manual.

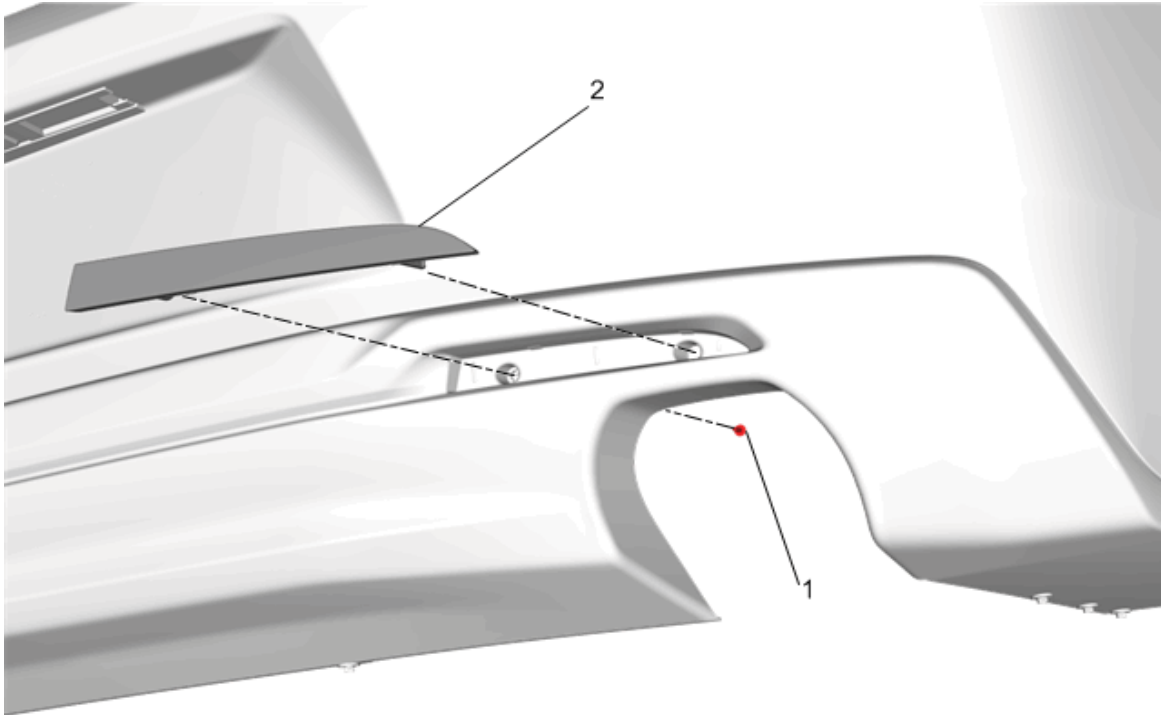

Caution: Use the correct fastener in the correct location. Replacement fasteners must be the correct part number for that application. Fasteners requiring replacement or fasteners requiring the use of thread locking compound or sealant are identified in the service procedure. Do not use paints, lubricants, or corrosion inhibitors on fasteners or fastener joint surfaces unless specified. These coatings affect fastener torque and joint clamping force and may damage the fastener. Use the correct tightening sequence and specifications when installing fasteners in order to avoid damage to parts and systems.

9. Remove the screws (1) and reflectors (2) from the rear bumper lower fascia and transfer them to new accessory valance. Tighten the screws to 2.5 N.m (22 lb in).



10. Position a supplied plastic template (1) on the side of the rear bumper (2). Use the front and bottom edges to align it. Tape it into position.
11. Drill (5) 7mm holes (3) through the rear bumper at the locations defined by the template.
12. Remove the template and remove any debris.
13. Drill holes on the opposite side of the rear bumper using the other supplied template and similar procedure.

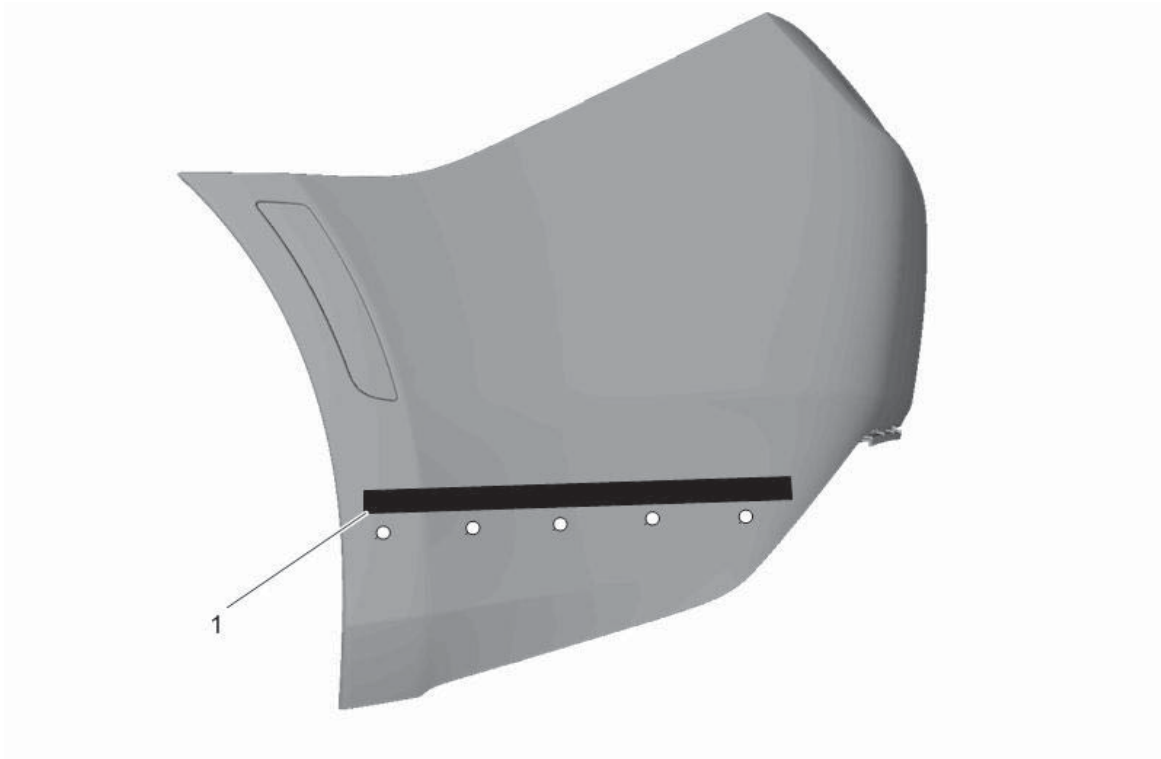

14. Add temporary protective tape (1) above the holes in the rear bumper on both sides to prevent scratching.



15. Attach the ACCESSORY SURROUND (3) to the ACCESSORY VALANCE (1). Do not attach the last 3 tabs (2) on each side yet.

16. Install ACCESSORY REAR ASSEMBLY to the rear bumper. Attach parts with care. Be careful not to bend attachment tabs as parts are assembled.

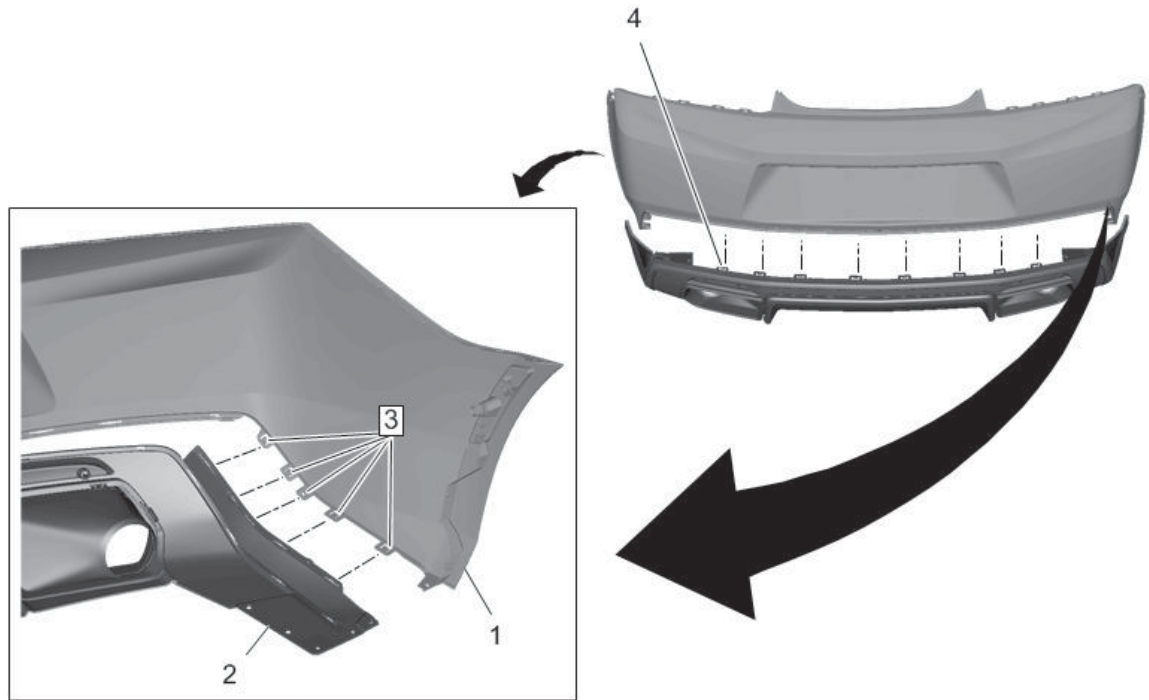

16.1. Start with the rear tabs (4).

16.2. Insert the sideways tabs (3) from the rear bumper (1) into the accessory valance (2).

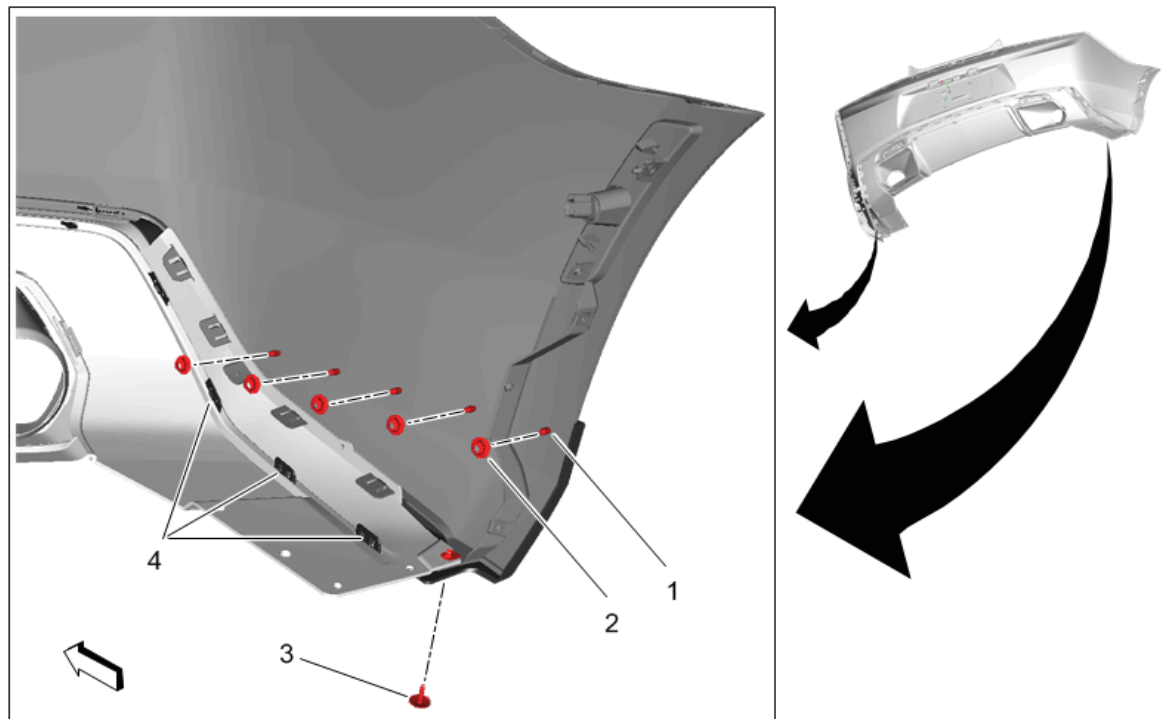

16.3. Install the corner screw (3).

- 16.4. Insert the plastic posts (1) on the inside of the accessory surround into the drilled holes in the rear bumper.
- 16.5. Insert the last 3 vertical tabs (4) from the accessory surround onto the accessory valance.
- 16.6. Make sure that all tabs are firmly and properly inserted.
- 16.7. remove the protective tape on the sides of the rear bumper from step 14.
- 16.8. Fasten the spin nuts (2) onto the plastic posts of the accessory surround. Make sure the gap between parts is closed. Repeat for the other side.
17. Reinstall energy absorber to rear bumper assembly. Reinstall any electrical wiring that was removed.

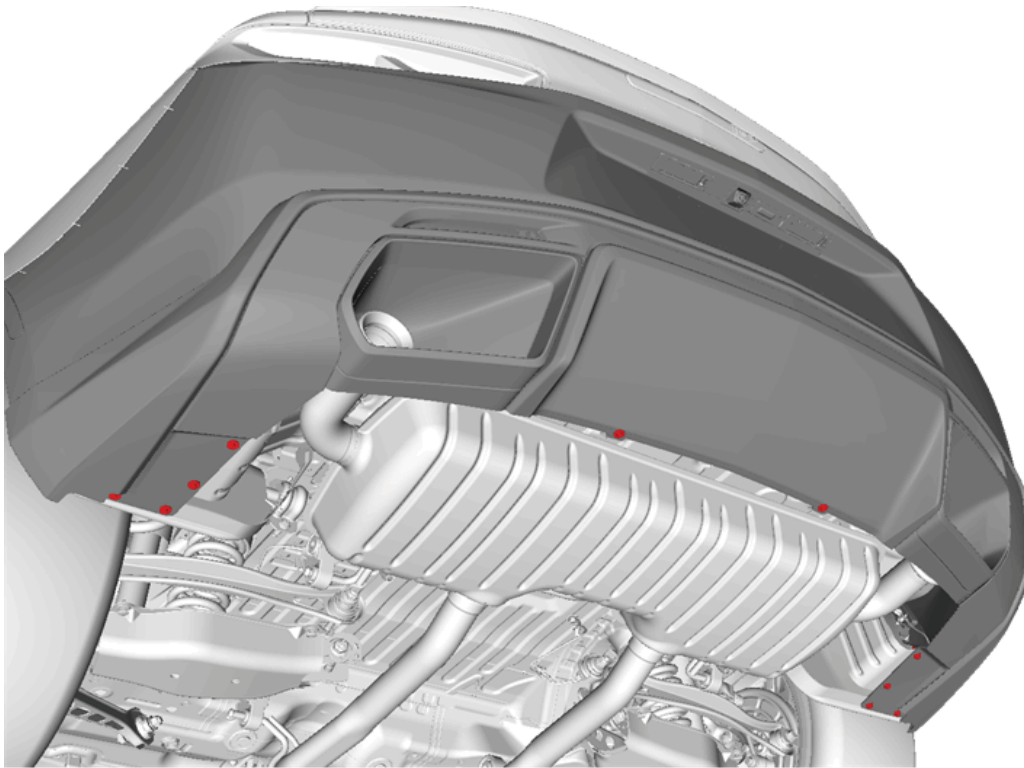

18. Reinstall rear bumper fascia assembly to the vehicle, make sure to attach all fasteners. Refer to Vehicle Service Manual.
19. Inspect installation for proper look and fit.
20. Lower the vehicle.