

# Front Fender Mud Guard Package Installation

## Installation Instructions Part Number

26393120

Please read instructions thoroughly before starting.

### Kit Contents

Qty	Description
1	Left Hand Splash Guard
1	Right Hand Splash Guard
2	Long Screw
2	Screw with washer
2	Short Screw
2	U-Nut
2	Rivet
1	Instruction Sheet

## Special Tools

- T15 Torx Screwdriver
- 5mm (13/64") Drill Bit/Drill
- Rivet Tool
- Awl
- Clean Cloth/Rag

## Procedure

1. Remove the front wheel and tire assembly. Refer to [Tire and Wheel Removal and Installation](#) in Vehicle Service Manual.
2. Clean and degrease body panel where splash guards are to be located.

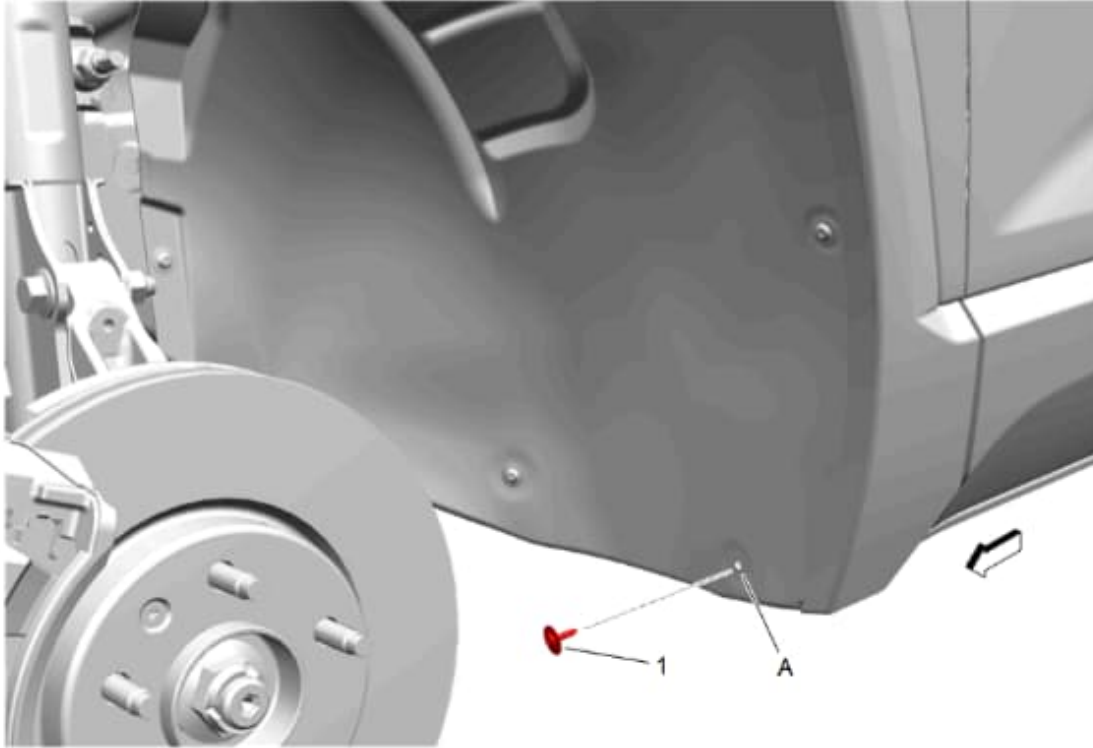

3. Remove the existing screw (1) at location **(A)** and discard but retain the U-nut.

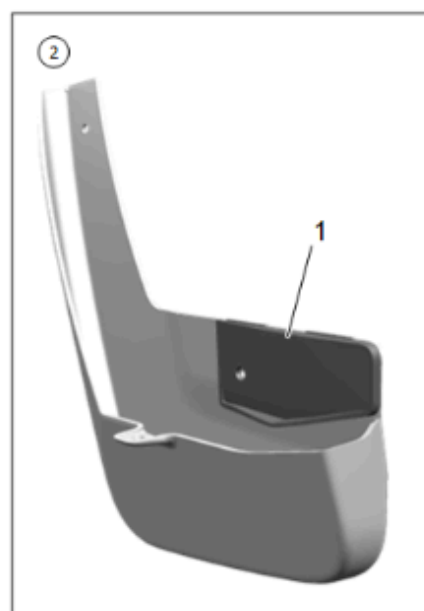
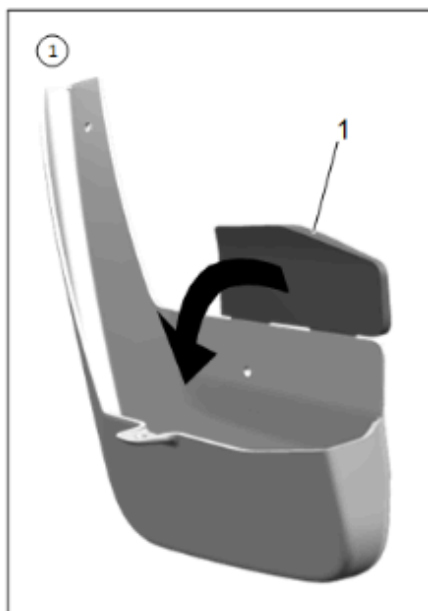

4. Take the new splash guard and make sure foldable hinge (1) is folded into place.



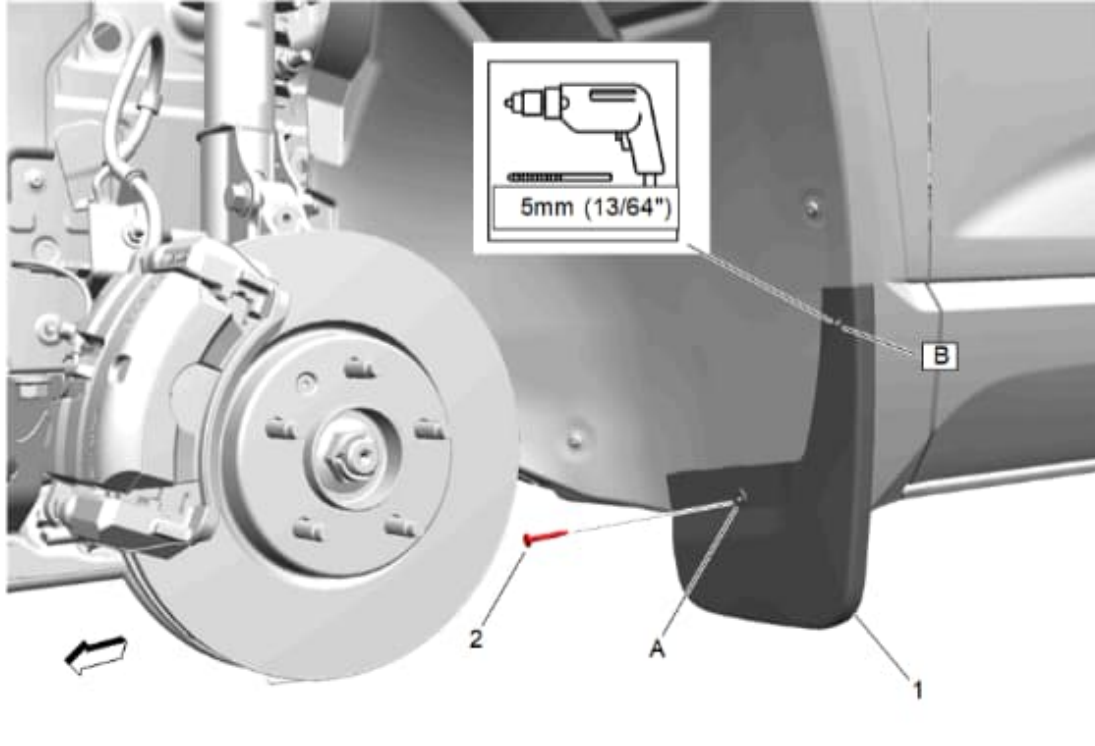

**Caution:** Use the correct fastener in the correct location. Replacement fasteners must be the correct part number for that application. Fasteners requiring replacement or fasteners requiring the use of thread locking compound or sealant are identified in the service procedure. Do not use paints, lubricants, or corrosion inhibitors on fasteners or fastener joint surfaces unless specified. These coatings affect fastener torque and joint clamping force and may damage the fastener. Use the correct tightening sequence and specifications when installing fasteners in order to avoid damage to parts and systems.

- Place the splash guard (1) to the vehicle, take care to remove any gaps and Install supplied long screw (2) with no washer at location **(A)**. Tighten screw to 3.0 N.m (2.0 lb ft).

**Caution:** Always check size and position of all holes before drilling. Failing to do so may cause damage to the vehicle, misalignment of components or the inability to install the accessory.

- While holding the splash guard (1) to the vehicle, take care to remove any gaps and carefully drill a 5.0 mm (13/64") hole at location **(B)**.
- Remove the screw (2) and the splash guard (1).

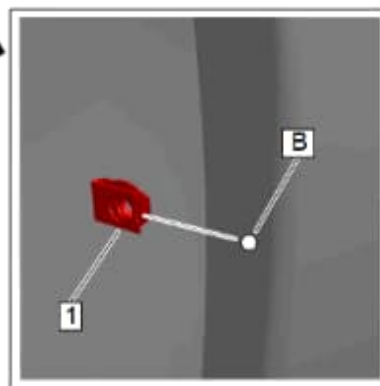
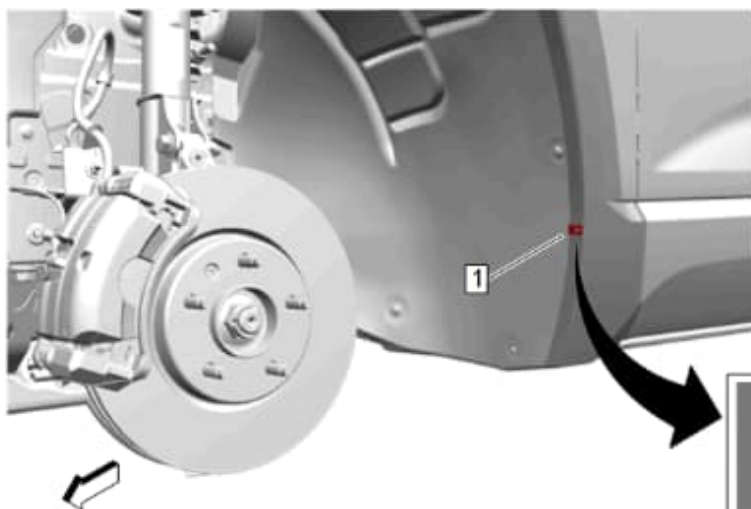

- Install supplied U-Nut (1) at location **(B)**.

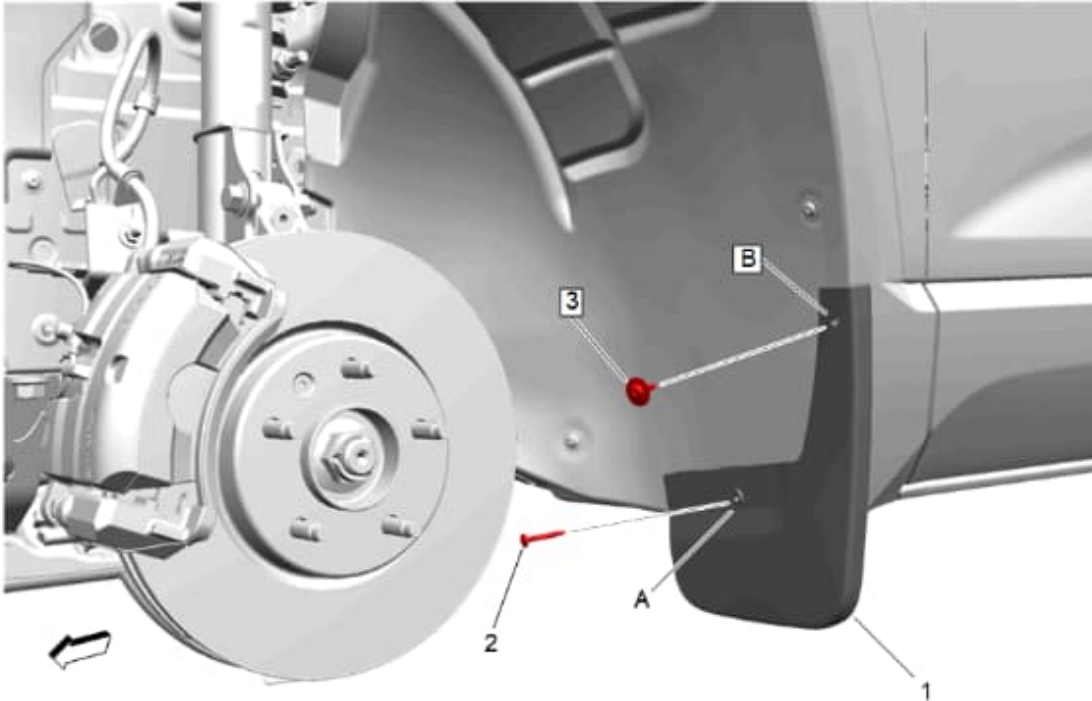

9. Install the splash guard (1) while holding the splash guard tightly to the vehicle to ensure there are no gaps, and install long screw (2) with no washer at location (A) and install screw (3) with washer at location (B). Tighten screws to 3.0 N.m (2.0 lb ft).

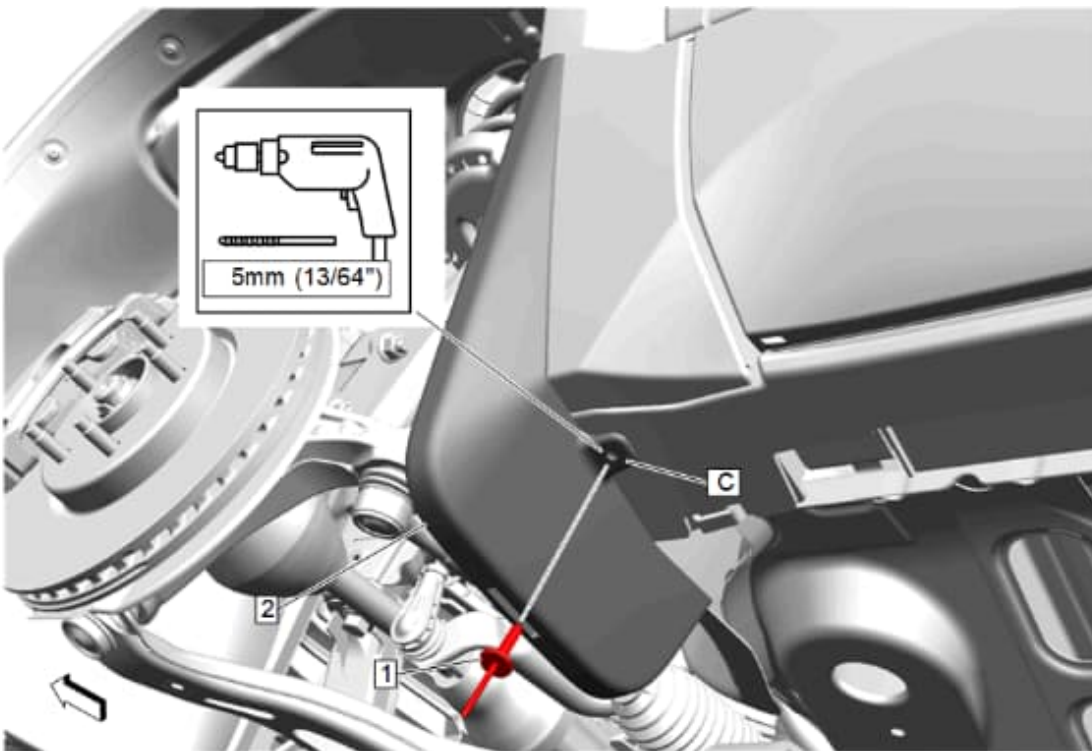

**Caution:** Always check size and position of all holes before drilling. Failing to do so may cause damage to the vehicle, misalignment of components or the inability to install the accessory.

10. While holding the splash guard (2) tight to the vehicle, take care to remove any gaps and carefully drill a 5.0 mm (13/64") hole at location (C).
11. Install supplied rivet at location (C).
12. Install the front wheel and tire assembly. Refer to [Tire and Wheel Removal and Installation](#) in Vehicle Service Manual.
13. Repeat procedure for other side.
14. Guards can be cleaned with any commercially available cleaner.