

Front Fender Mud Flap Package Installation

[Installation Instructions Part Number](#)

26496127

Please read instructions thoroughly before starting.

Qty	Description
1	Left Hand Splash Guard
1	Right Hand Splash Guard
1	Left Hand Bracket
1	Right Hand Bracket
2	Short Screw
2	Long Screw
2	Short Bolt With Washer
4	Washer
2	Rivet
6	U-Nut
1	Instruction Sheet

[Tools Required](#)

- T15 Torx Screwdriver
- 5mm (13/64") Drill Bit/Drill
- Rivet Gun
- Awl
- Clean Cloth/Rag

[Procedure](#)

1. Remove the front wheel and tire assembly. Refer to [Tire and Wheel Removal and Installation](#) in Vehicle Service Manual.
2. Clean and degrease body panel where splash guards are to be located.

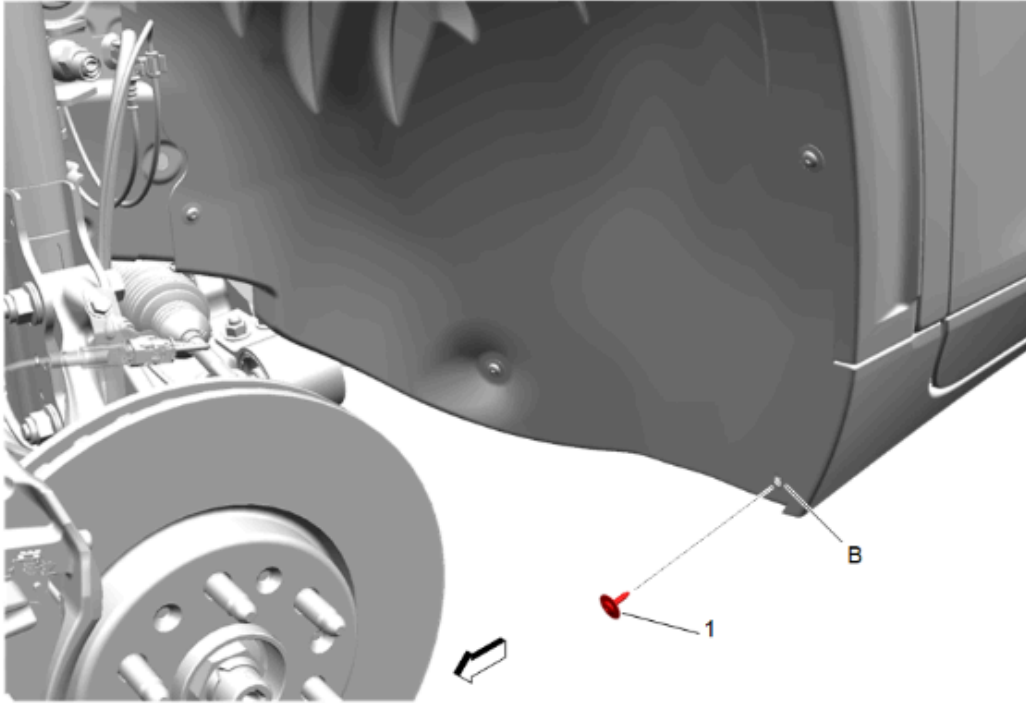

3. Remove existing screw (1) at location **(B)** and retain screw.

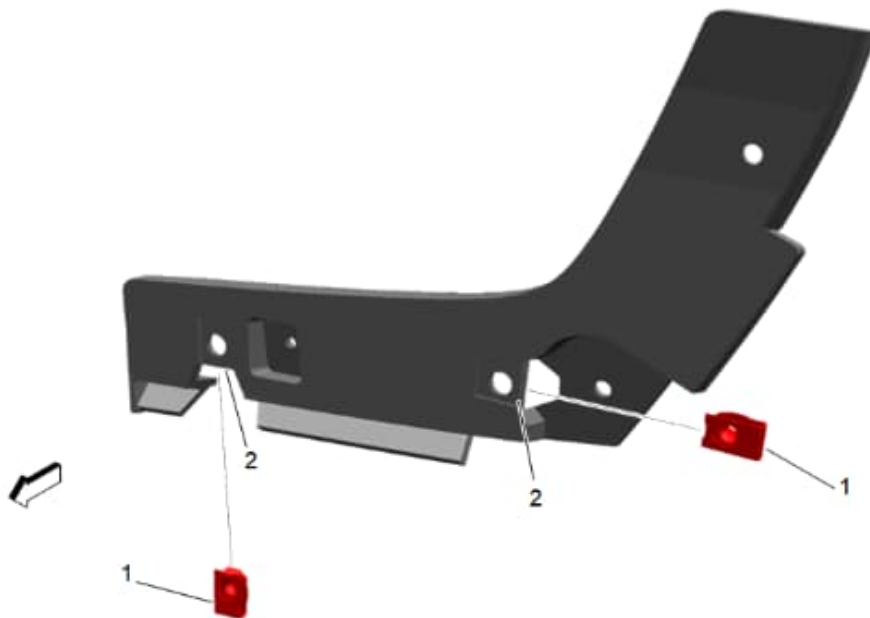

4. Install supplied U-nuts (1) onto the bracket (2).

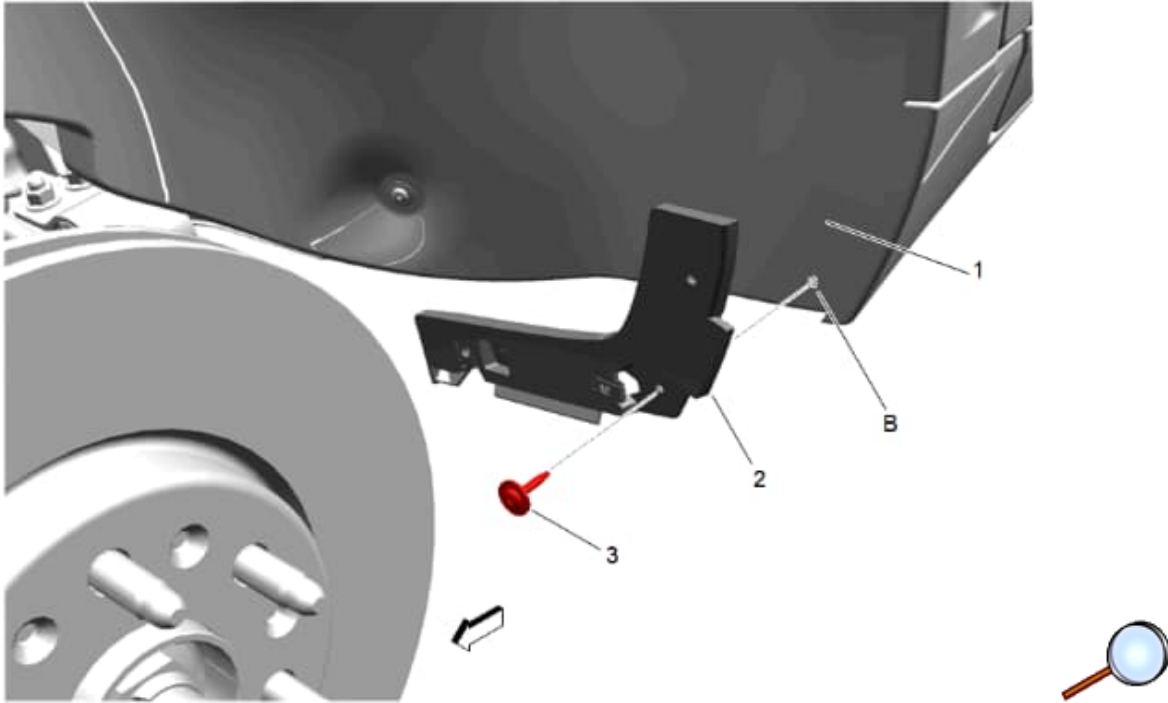

Caution: Use the correct fastener in the correct location. Replacement fasteners must be the correct part number for that application. Fasteners requiring replacement or fasteners requiring the use of thread locking compound or sealant are identified in the service procedure. Do not use paints, lubricants, or corrosion inhibitors on fasteners or fastener joint surfaces unless specified. These coatings affect fastener torque and joint clamping force and may damage the fastener. Use the correct tightening sequence and specifications when installing fasteners in order to avoid damage to parts and systems.

5. Install bracket (2) to the wheel liner (1) with short screw (3) and washer at location (B).

Tighten

Tighten screw to 3.0 N.m (2.0 lb ft)

Caution: Always check size and position of all holes before drilling. Failing to do so may cause damage to the vehicle, misalignment of components or the inability to install the accessory.

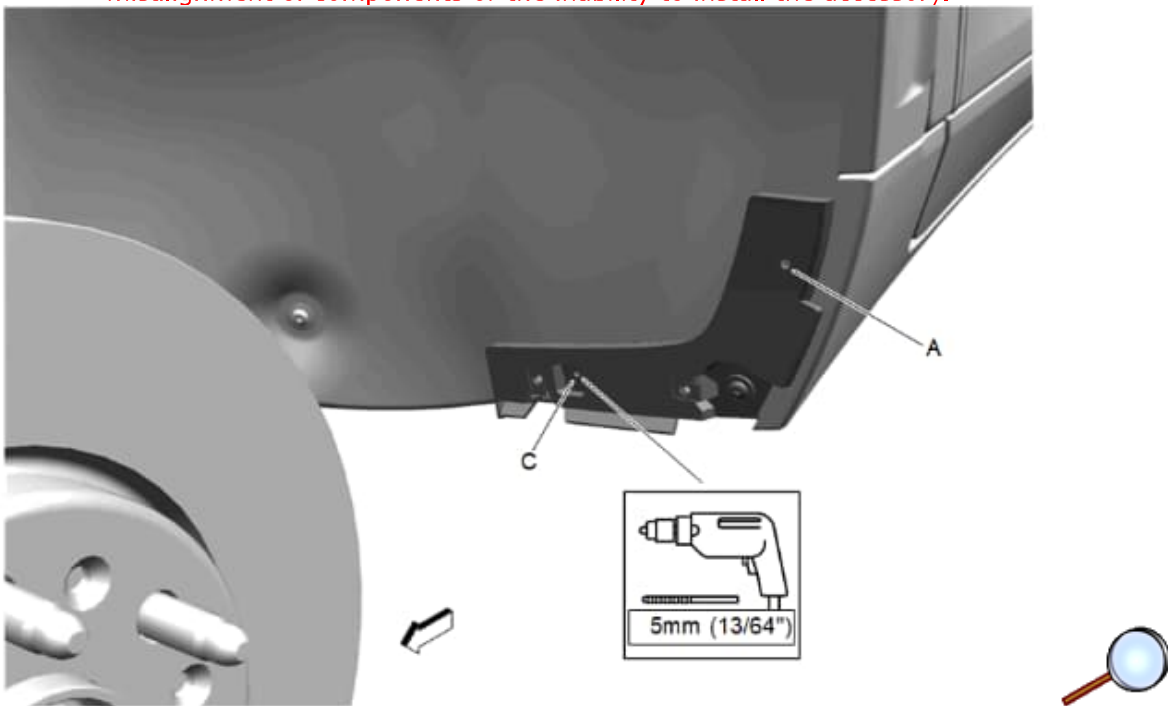

6. While holding the bracket firmly to the vehicle, carefully drill a 5mm (13/64") hole at location (C) and then use awl to punch hole at location (A).

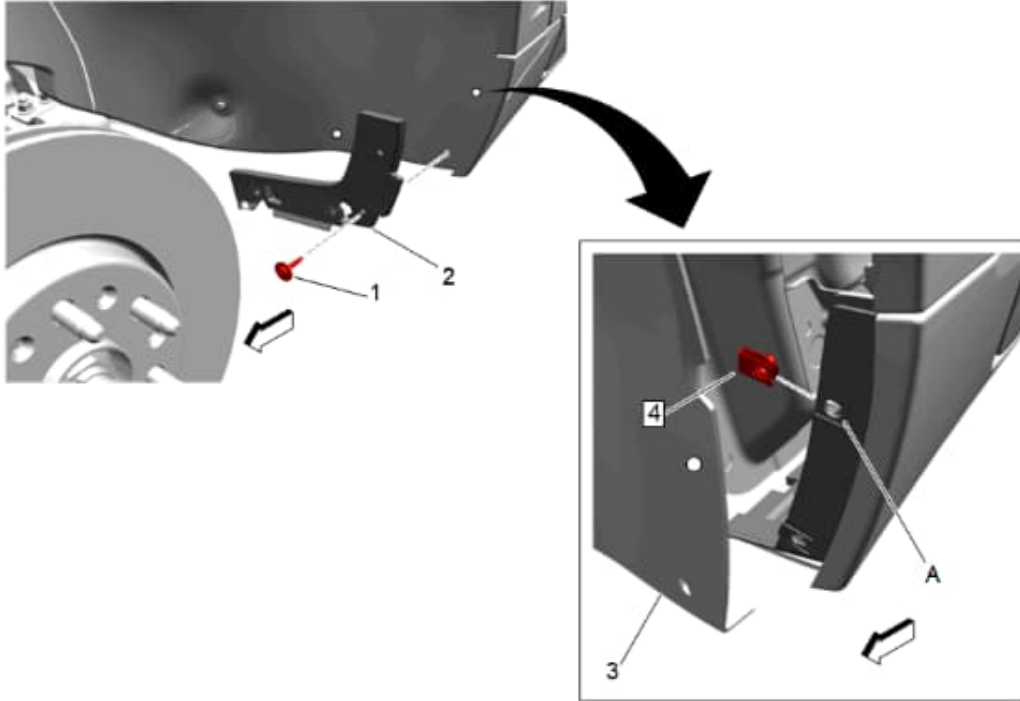

7. Remove the screw (1), washer and bracket (2). Carefully peel back wheel liner (3) and place U-nut (4) at location **(A)**.

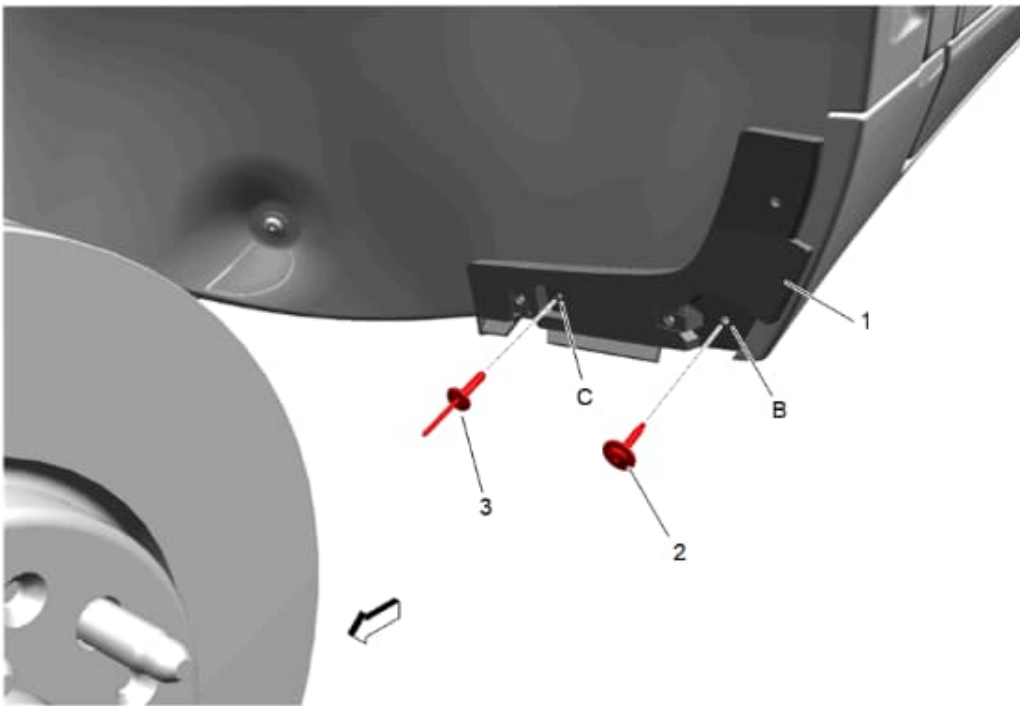

8. Re-Install bracket (1) with short screw (2) and washer at location **(B)**.

Tighten

Tighten screw to 3.0 N.m (2.0 lb ft)

9. Install supplied rivet (3) at location **(C)**.

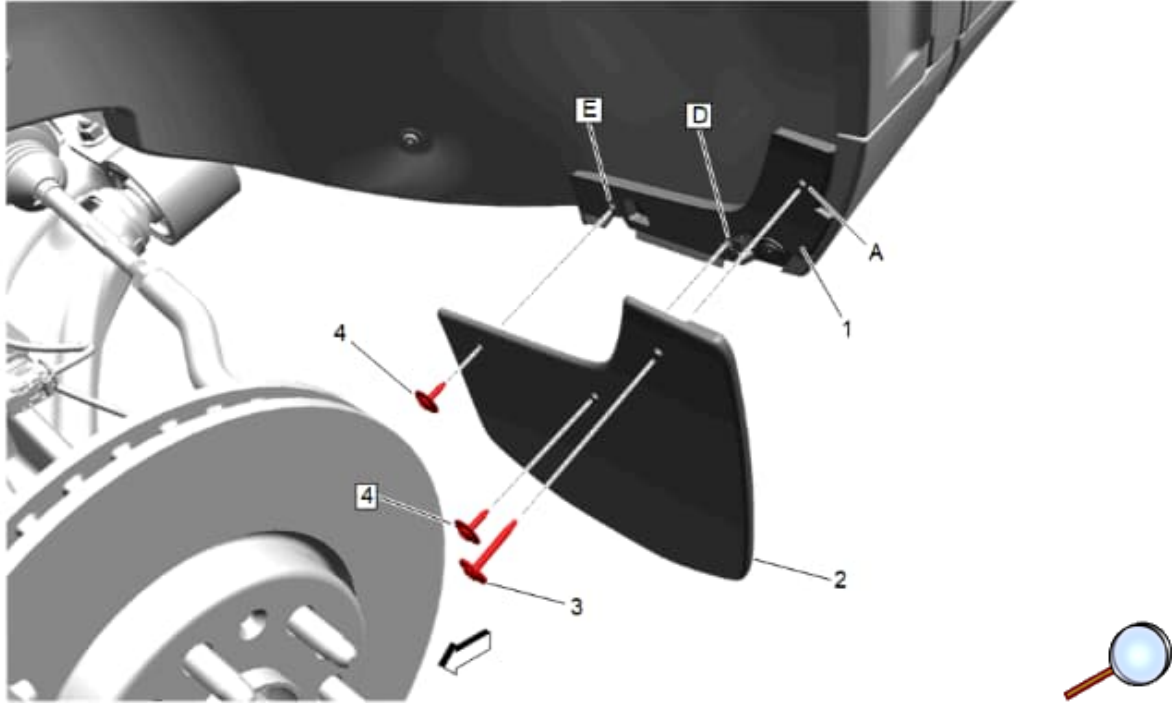

10. Install splash guard (2) to vehicle, make it is placed properly to bracket (1).

11. Install long screw (3) and washer at location **(A)**, install short screw (4) at location **(D)**. Install short screw (4) with attached washer that was removed in step 3 at location **(E)**.

Tighten

Tighten Tighten screws to 3.0 N.m (2.0 lb ft).

12. Install the front wheel and tire assembly. Refer to [Tire and Wheel Removal and Installation](#) in Vehicle Service Manual.

13. Repeat procedure for other side.

14. Guards can be cleaned with any commercially available cleaner.