

Front Fender Mud Flap Package Installation

Installation Instructions Part Number

84110083

Note: Please read instructions thoroughly before starting.

Front Fender Mud Flap Kit Contents

Qty	Description
1	Left Hand Splash Guard
1	Right Hand Splash Guard
1	Instruction Sheet

Tools Required

- T15 Screw Driver
- Ratchet
- 10 mm Hex Socket
- Clean Cloth/Rag

Installation Procedure

Note: If the wheel liner and the splash guards are being installed at the same time. Wheel Liner must be installed first and then the splash guard.

Note: Do not use power tools to install fasteners.

1. Turn front wheel/tire to provide clearance.
2. Clean and degrease body panel where splash guards will be located.

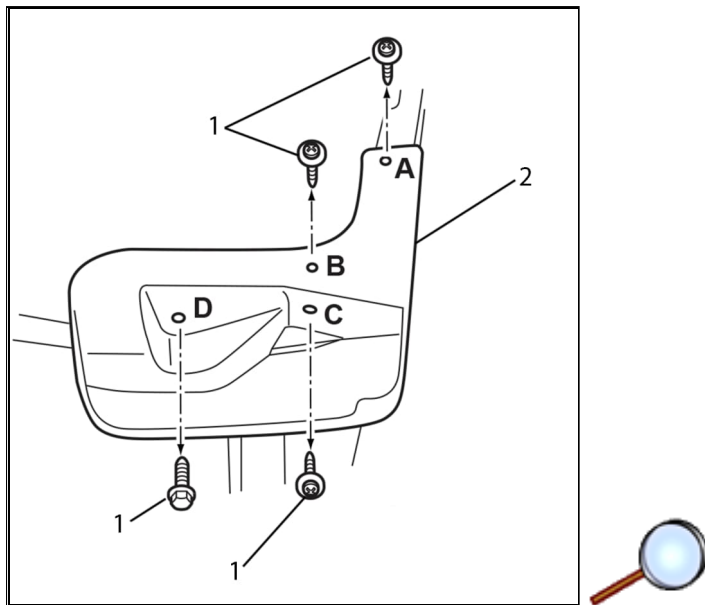

3. Remove existing fasteners (1) at locations (A), (B), (C) and (D) and remove stone protector. Retain fasteners. Remove the existing stone protector (2).

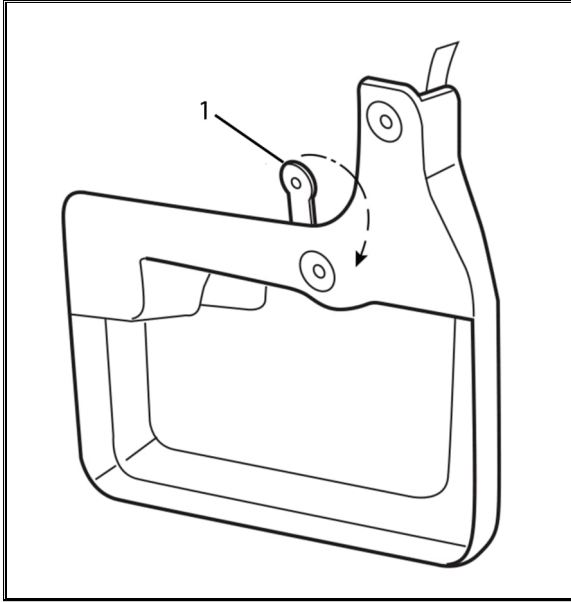

4. Fold splash guard living hinge (1) down.

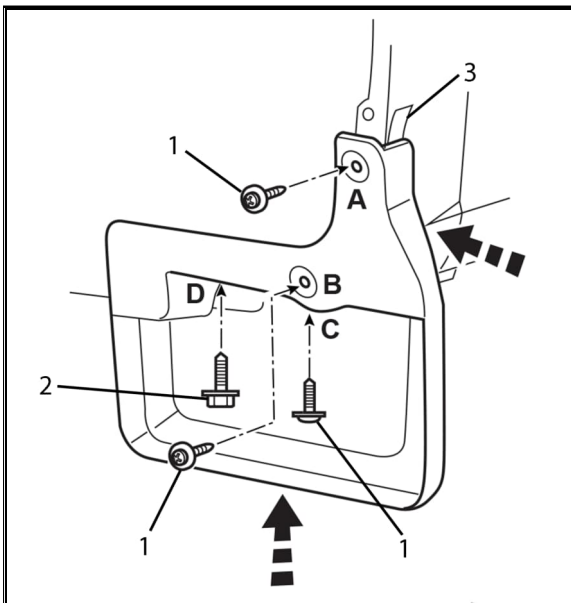

Caution: Use the correct fastener in the correct location. Replacement fasteners must be the correct part number for that application. Fasteners requiring replacement or fasteners requiring the use of thread locking compound or sealant are identified in the service procedure. Do not use paints, lubricants, or corrosion inhibitors on fasteners or fastener joint surfaces unless specified. These coatings affect fastener torque and joint clamping force and may damage the fastener. Use the correct tightening sequence and specifications when installing fasteners in order to avoid damage to parts and systems.

5. While holding living hinge closed, place splash guard to vehicle taking care to remove any gaps, make sure red tape pull tab (3) is accessible, and install retained M4.2 x 20 screws (1) with washers at locations (A), (B) and (C) and install retained hex bolt (2) at location (D).

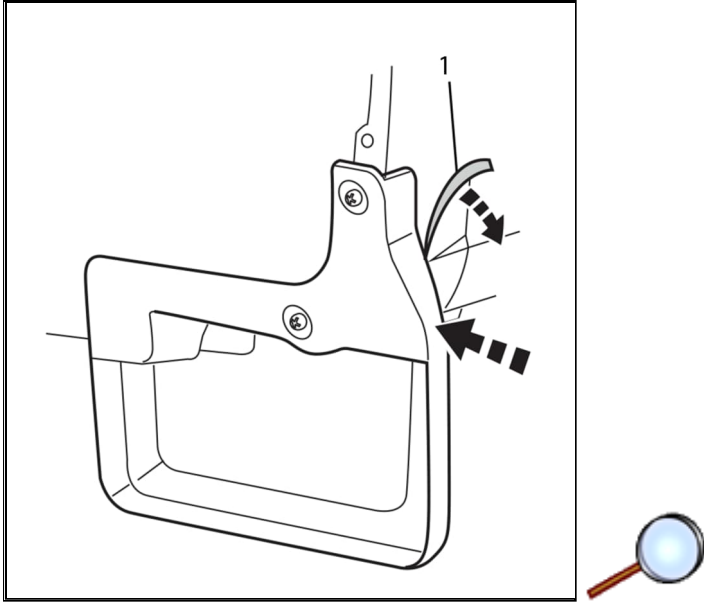

6. Remove tape liner (1) and apply firm pressure to the splash guard along the tape line to adhere the tape to the fender. Hold firm pressure for a minimum of 60 seconds to properly adhere the tape.
7. Repeat for other side.
8. Guards can be cleaned with any commercially available cleaner.

Note: Maximum torque on M4.2 screw is 3.0 N•m.