

# Rear Mud Guard Package Installation (Instruction ID: 84110086)

## Installation Instructions Part Number

84110086

**Note:** Please read instructions thoroughly before starting.

### Rear Mud Flap Kit Contents

Qty	Description
1	Left Hand Splash Guard
1	Right Hand Splash Guard
2	M4.2 x 20 Screw with Washer
2	M4.2 U-nut
4	Rivet
1	Instruction Sheet

### Tools Required

**Note:** Do not use power tools to install fasteners.

- T15 Screw Driver
- Drill
- 13/64" (5.0mm) Drill Bit
- Rivet Gun
- Awl
- Pliers
- Clean Cloth/Rag
- Torque Wrench with T15 Head

### Installation Procedure

1. Remove the rear wheel and tire. Refer to Vehicle Service Manual.
2. Clean and degrease body panel where splash guards will be located.

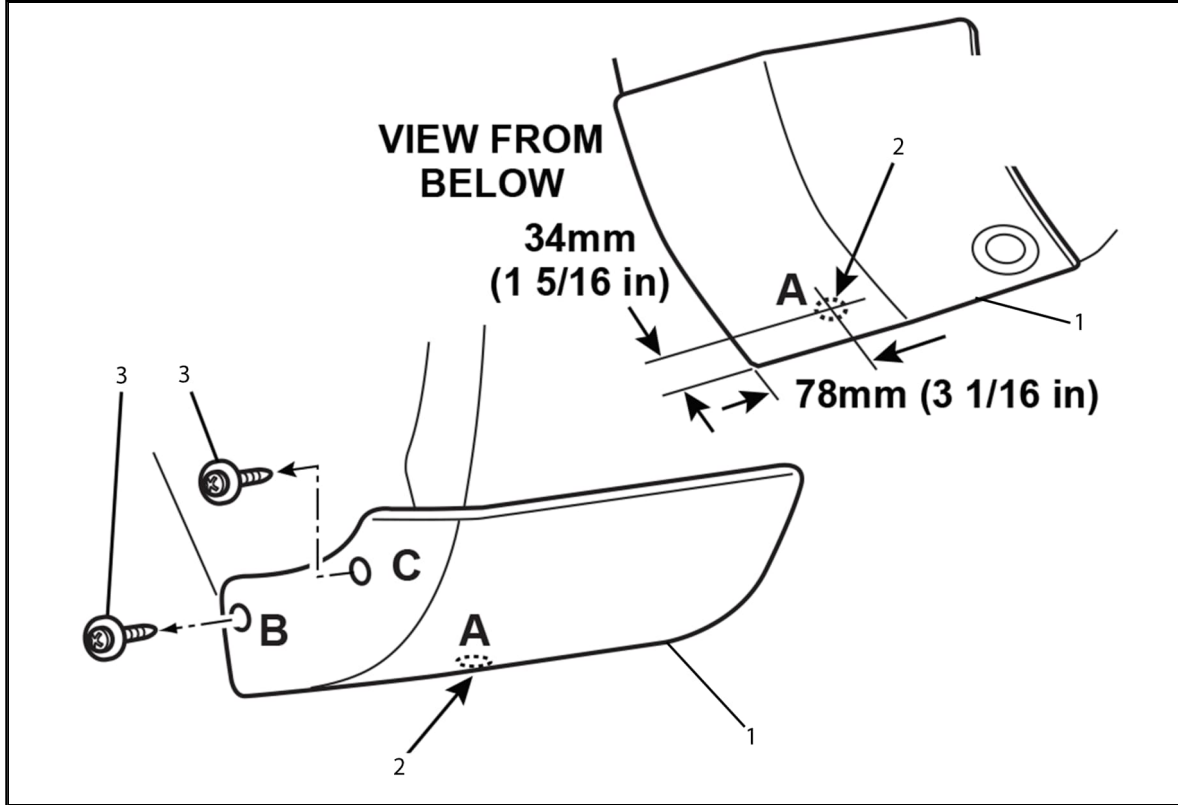

3. Measure and mark new hole (2) location at (A) on stone protector (1). Using a 13/64" (5.0mm) bit, drill hole at location (A).
4. Remove existing screws (3) at locations (B) and (C). Retain fasteners.

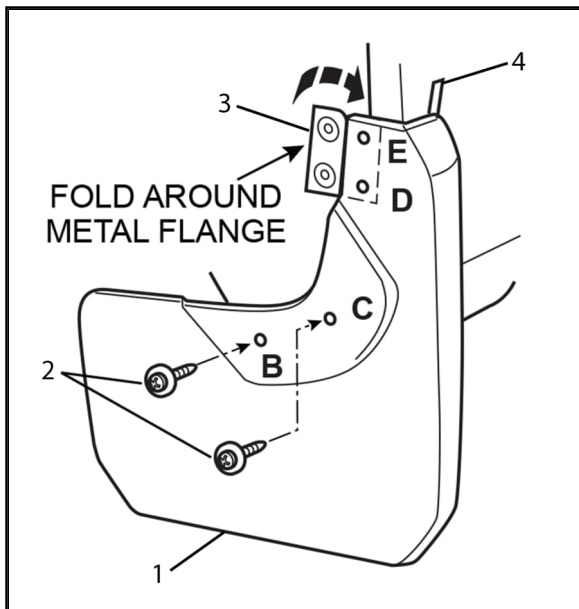

**Caution:** Use the correct fastener in the correct location. Replacement fasteners must be the correct part number for that application. Fasteners requiring replacement or fasteners requiring the use of thread locking compound or sealant are identified in the service procedure. Do not use paints, lubricants, or corrosion inhibitors on fasteners or fastener joint surfaces unless specified. These coatings affect fastener torque and joint clamping force and may damage the fastener. Use the correct tightening sequence and specifications when installing fasteners in order to avoid damage to parts and systems.

5. Place splash guard (1) to vehicle, make sure red tape pull tab (4) is accessible, then fold splash guard top living hinge (3) to sandwich splash guard to body side outer flange and install retained fasteners (2) at locations (B) and (C). Take care to eliminate gaps. Tighten fasteners to 3.0 N.m.

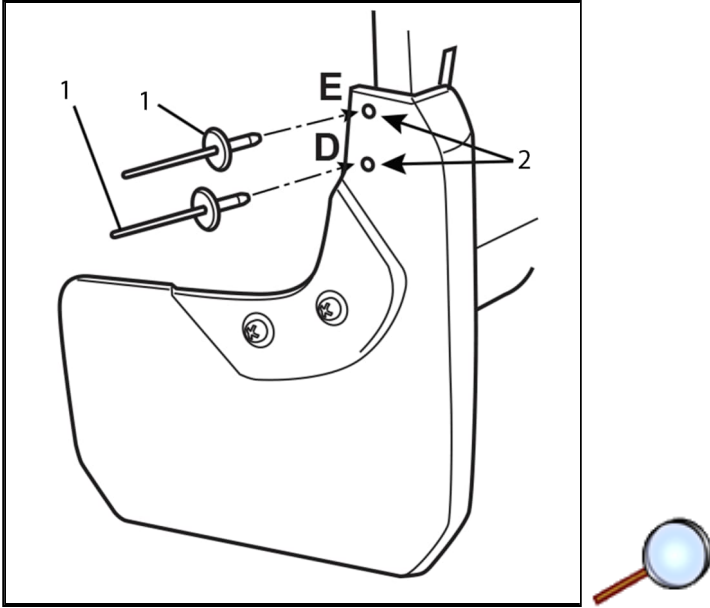

6. While keeping living hinge folded and pinched around body side outer, drill through splash guard hole (2) locations (D) and (E). Using a 13/64" (5.0mm) bit, drill through splash guard and wheel liner.
7. Install supplied rivets (1) in newly drilled holes (2) at (D) and (E). Living hinge should firmly pinch to body side outer flange.

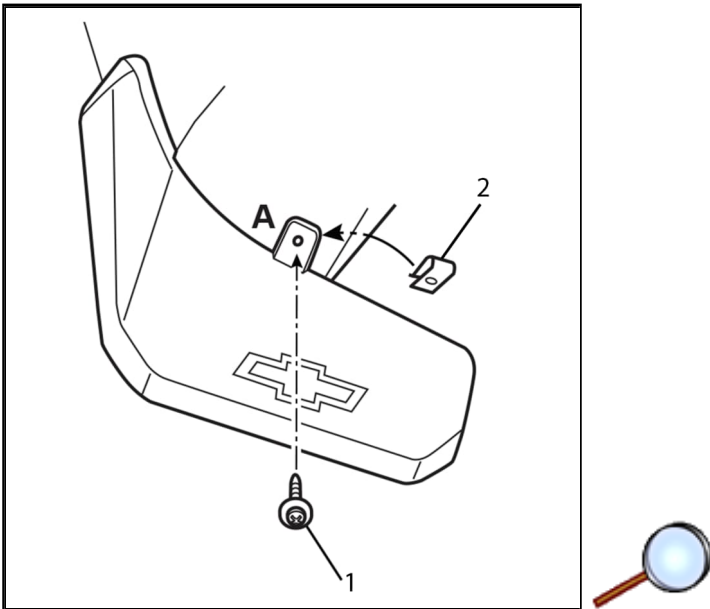

8. Pull splash guard tab rearward and inward to align tab hole to newly drilled hole at location (A) and remove gap to vehicle. Install supplied M4.2 screw w/washer (1) and supplied U-nut (2) at location (A). The U-nut (2) should be used as a nut above the stone protector and body side outer. Tighten M4.2 screw to 3.0 N.m.

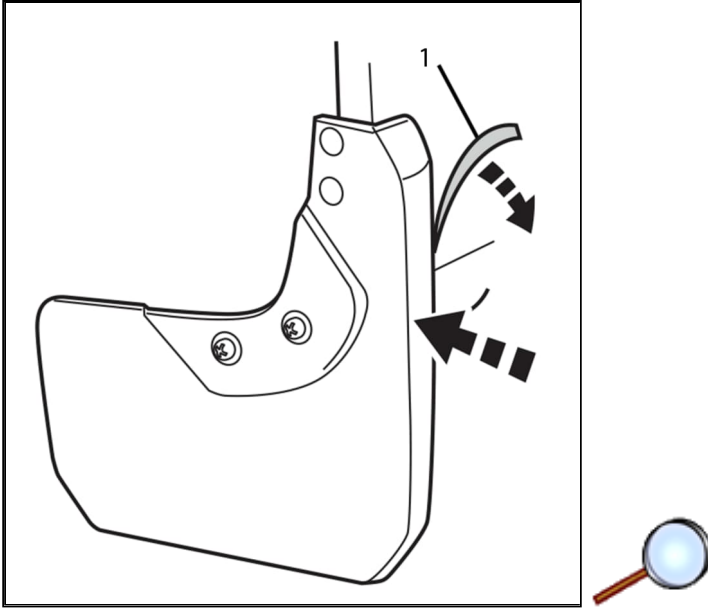

9. Remove tape liner (1) and apply firm pressure to the splash guard along the tape line to adhere the tape to the fender. Hold the firm pressure for a minimum of 60 seconds to properly adhere the tape.
10. Repeat for other side.
11. Guards can be cleaned with any commercially available cleaner.