

Body Emblem Package Installation

Table 1: [Kit Contents 84141155](#)

Table 2: [Kit Contents 84100081](#)

Installation Instructions Part Number

84141153

Kit Contents 84141155

Qty	Description
1	Illuminated Emblem Assembly Bow Tie – Front
1	Wire Harness
6	Wire Harness Strap
1	Installation Instructions

Kit Contents 84100081

Qty	Description
1	Illuminated Emblem Assembly Bow Tie – Front
1	Wire Harness
6	Wire Harness Strap
1	Emblem Assembly Bow Tie (Black) – Rear
1	Installation Instructions

Before you start

Note: For the nameplate to adhere best, the vehicle's mating surface (doors, rear compartment, etc.) should be free of damage (dents, scratches, creases, fractures, etc.).

Caution: Do not use heat gun/hair dryer or apply excessive heat to the emblem/nameplate as this may damage the paint and surrounding panel surfaces during removal.

Caution: Use a plastic, flat-bladed tool to prevent paint damage when removing an emblem/nameplate. Do not use fishing line to remove nameplate as this may worsen the tape residue cleaning process. Use Isopropyl Alcohol and Lint Free Cloth to remove tape residue. Heavy foam/adhesive residue remaining on the painted surface can be removed using 3M's Scotch-Brite™ Molding Adhesive and Stripe Removal 4-inch Foam Disc.

Caution: Only install nameplates as a direct replacement of the existing vehicle content.

- The part and surface should be 21°C (70°F) prior to installation. The vehicle should remain 21°C (70°F) for one hour after assembly to allow adhesive to develop sufficient bond strength.
- Wash the vehicle mating surfaces with a non-petroleum based cleaning product. If a stronger cleaner is required to remove any contaminants, use 3M general purpose Adhesive Cleaner (P/N 08984). Then, thoroughly dry with a soft clean cloth.

Procedure

Front Bow Tie Emblem Replacement

- Read all instructions before performing procedure.
- Inspect kit to verify all parts are included.
- Turn off the vehicle.
- Open the hood.
- Remove the front bumper fascia from vehicle. Refer to [Front Bumper Fascia Replacement](#) in Vehicle Service Manual.

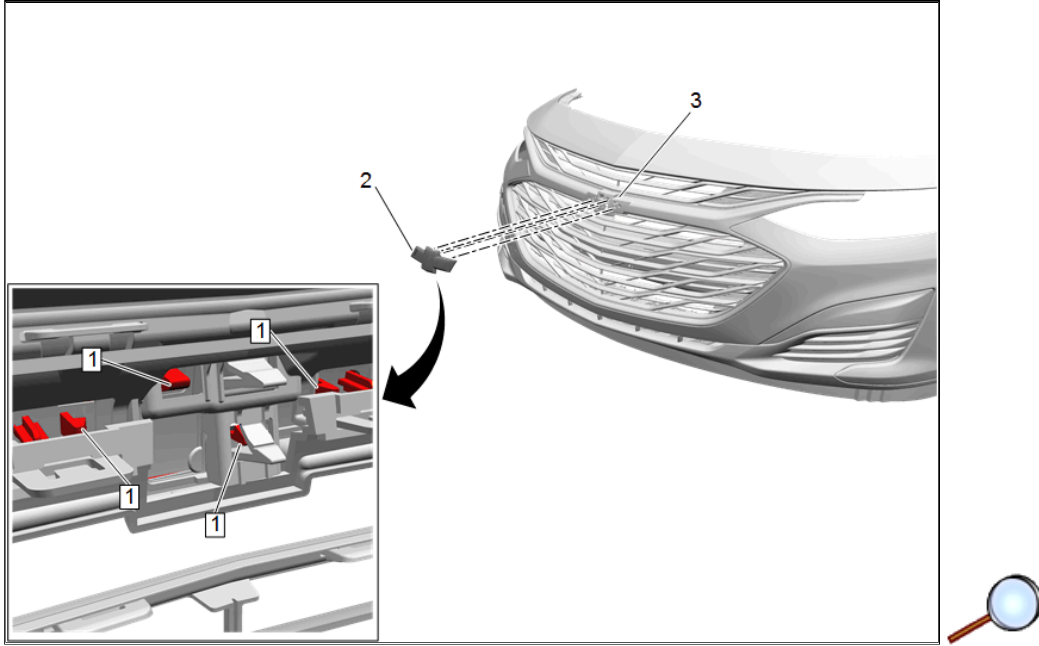

6. On the backside of the fascia, disengage the retaining tabs (1) and remove the production bowtie emblem (2) from the fascia (3).

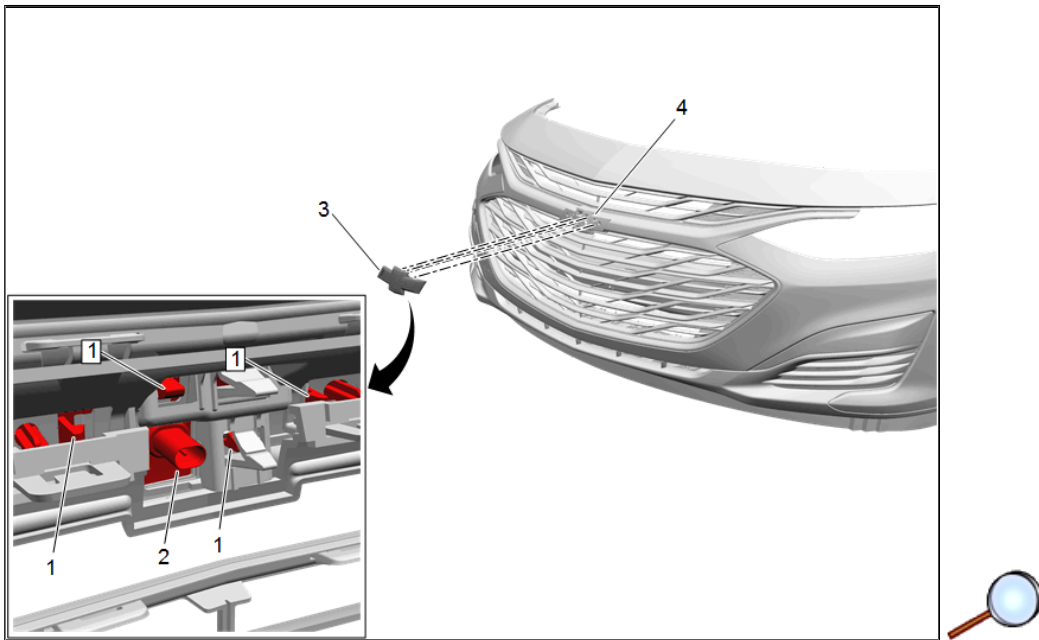

7. Install the illuminated bowtie emblem (3) to the fascia (4), position the emblem connector (2) to the existing hole applying enough evenly distributed pressure to engage the retention tabs (1).

Note: Wiggle the retention tabs (1) to make sure they are fully engaged.

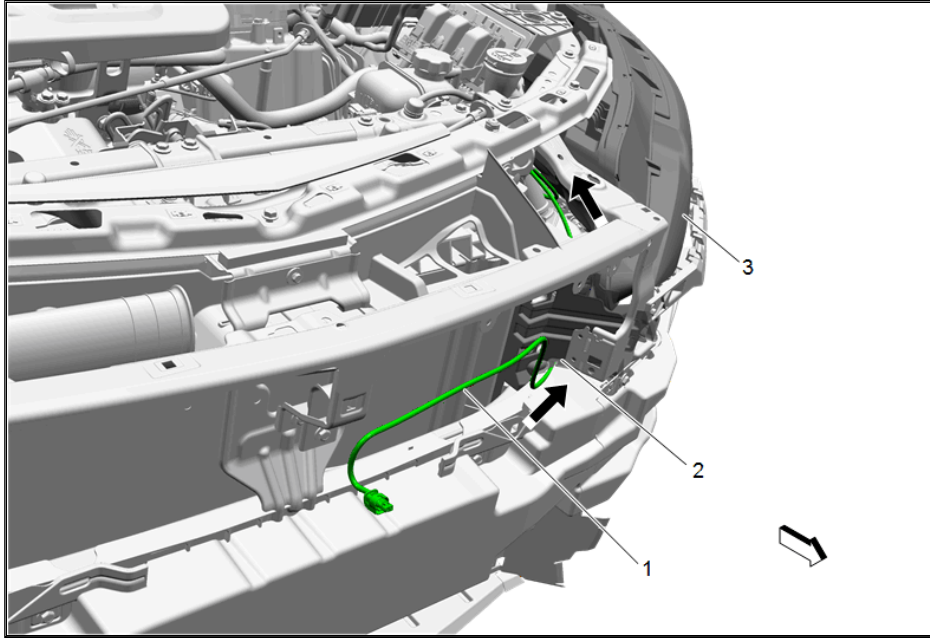

8. Route the one end of wire harness (1) with the two connectors at the end under the left radiator deflector (2) towards the back of the left headlamp assembly (3).

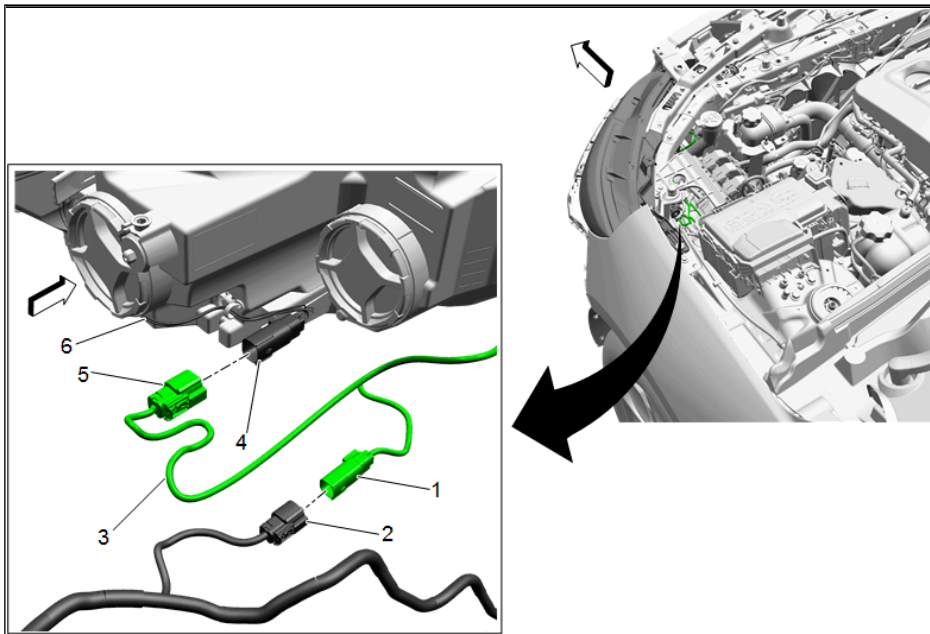

9. Continue to route harness (3) behind the left side headlamp assembly (6).
10. Disconnect the left side headlamp harness connector (2) from the left side headlamp (4).
11. Connect one end of the accessory harness (5) to the left side headlamp (4).
12. Connect the other end of the accessory harness (1) the left side headlamp harness connector (2).

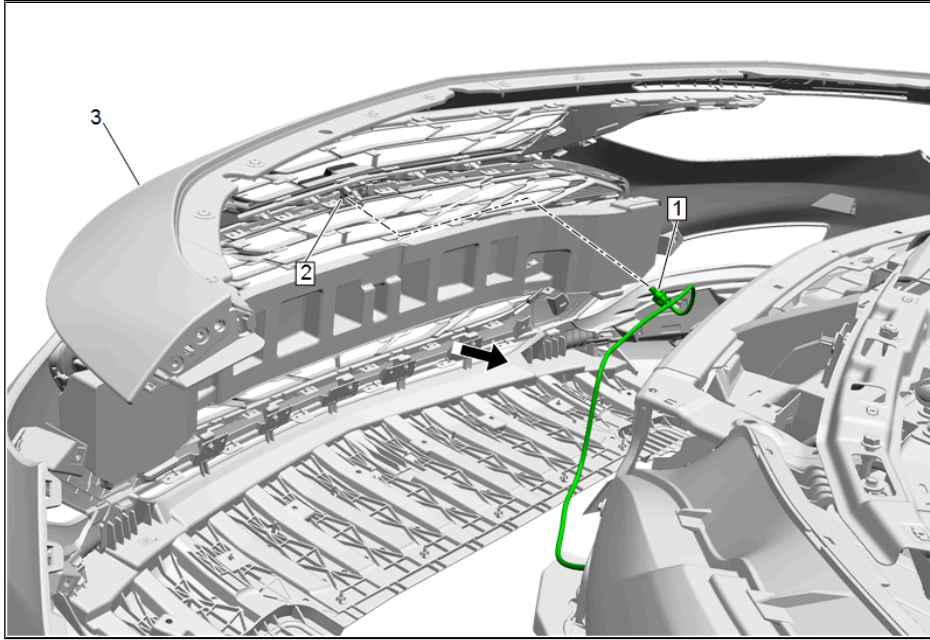

13. Position the front fascia assembly (3) to the vehicle.
14. Connect the single connector end of harness (1) to the illuminated bowtie emblem (2).
15. Reposition and re-install the front bumper fascia. Refer to [Front Bumper Fascia Replacement](#) in Vehicle Service Manual.
16. Use provided cable ties to secure accessory harness to the left headlamp harness bundle.
17. Test and confirm front lighting operation (headlamp, fog lamp and illuminated emblem).
18. Close the hood.

Rear Bow Tie Emblem Replacement

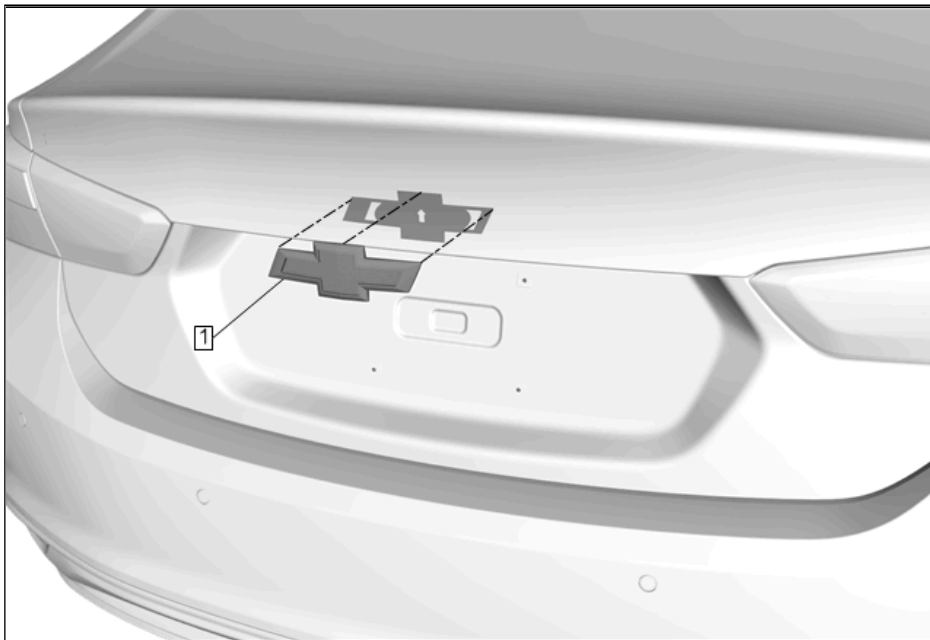

1. Mark the position of the emblem with a washable marker or masking tape prior to removal.
2. Carefully use a plastic flat-bladed tool to remove the existing emblem (1) from the painted sheet metal surface.
3. Clean any remaining residue with a 50/50 mixture by volume of isopropyl alcohol and clean drinkable water. Wipe surface dry with a clean lint-free towel.
4. Clean the surface with where the emblem will go.
5. The part surface should be 21°C (70°F) prior to installation. The vehicle should remain 21°C (70°F) for one hour after assembly to allow adhesive to develop sufficient bond strength.
6. When removing protective liners from the adhesive tape, be careful not to touch tape with hands and do not allow tape to come in contact with dirt or any foreign matter prior to adhesion.
7. Position new emblem (1) carefully within reference marks and place on prepared surface of rear compartment lid.
8. Using the palm of the hand, apply strong pressure to all areas of the emblem to ensure full adhesion is achieved.
9. Carefully remove any markings, tape, or the template used to locate the rear emblem. Clean the rear compartment surface as needed.