

# Body Emblem Package Installation

## Installation Instructions Part Number

84161256

### Kit Contents

| Qty | Description  |
|-----|--|
| 2   | Nameplate (Fender) – "SILVERADO" (If Equipped)     |
| 2   | Nameplate (Fender) – "HIGH COUNTRY" (If Equipped)  |
| 2   | Nameplate (Fender) – "Z71" (If Equipped)           |
| 2   | Nameplate (Fender) – "ZR2" (If Equipped)           |
| 1   | Nameplate (Endgate) – "SILVERADO" (If Equipped)    |
| 1   | Nameplate (Endgate) – "LT" (If Equipped)           |
| 1   | Nameplate (Endgate) – "HIGH COUNTRY" (If Equipped) |
| 1   | Nameplate (Endgate) – "ZR2" (If Equipped)          |
| 2   | Nameplate (Hood) – "6.2L" (If Equipped)            |
| 2   | Nameplate (Hood) – "DURAMAX" (If Equipped)         |
| 2   | Nameplate (Hood) – "TURBOMAX" (If Equipped)        |
| 1   | Nameplate (Grille) – "Z71" (If Equipped)           |
| 1   | Nameplate (Grille) – "ZR2" (If Equipped)           |
| 1   | Installation Instructions                          |

### Tools Required

Masking Tape

Rubber Roller (If available)

Scissors

Suitable flat-bladed tool

Plastic flat-bladed tool

### Before you start

**Note:** For the nameplate to adhere best, the vehicle's mating surface (doors, rear compartment, etc.) should be free of damage (dents, scratches, creases, fractures, etc.).



**Caution:** Do not use heat gun/hair dryer or apply excessive heat to the emblem/nameplate as this may damage the paint and surrounding panel surfaces during removal.



**Caution:** Use a plastic, flat-bladed tool to prevent paint damage when removing an emblem/nameplate. Do not use fishing line to remove nameplate as this may worsen the tape residue cleaning process. Use Isopropyl Alcohol and Lint Free Cloth to remove tape residue. Heavy foam/adhesive residue remaining on the painted surface can be removed using 3M's Scotch-Brite™ Molding Adhesive and Stripe Removal 4-inch Foam Disc. DO NOT use hard Stripe off wheel.

**Caution:** Only install nameplates as a direct replacement of the existing vehicle content.

1. The part and surface should be 21°C (70°F) prior to installation. The vehicle should remain 21°C (70°F) for one hour after assembly to allow adhesive to develop sufficient bond strength.
2. Wash the vehicle mating surfaces (Grille, Door or Endgate) with a non-petroleum based cleaning product. If a stronger cleaner is required to remove any contaminants, use 3M general purpose Adhesive Cleaner (P/N 08984). Then, thoroughly dry with a soft clean cloth.

## Procedure

### Grille Nameplate (Z71)

1. Remove the front grille. Refer to [Front Grille Replacement](#) in Vehicle Service Manual.

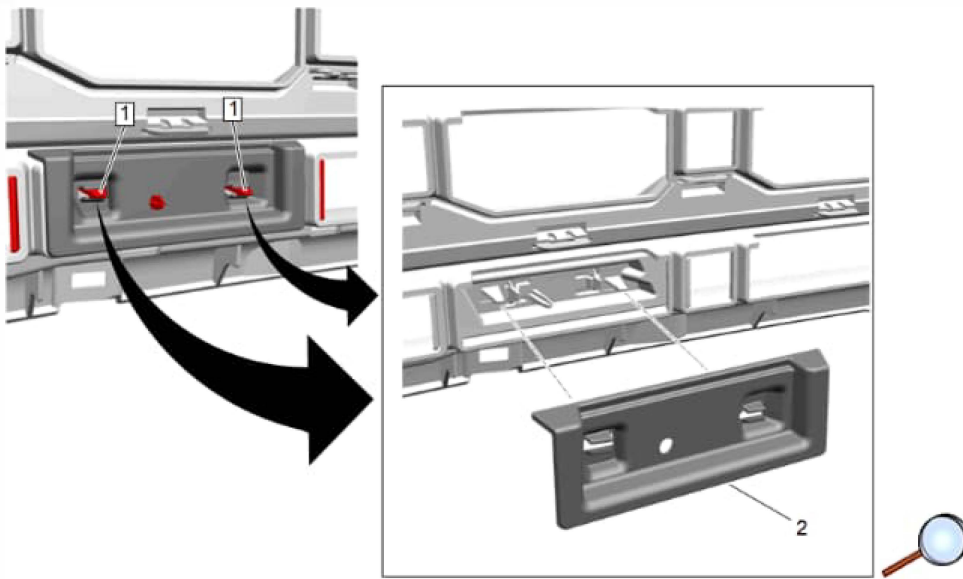

2. Using a suitable flat-bladed tool, release the two locking tabs (1) and remove the retainer (2) from the front grille emblem housing.

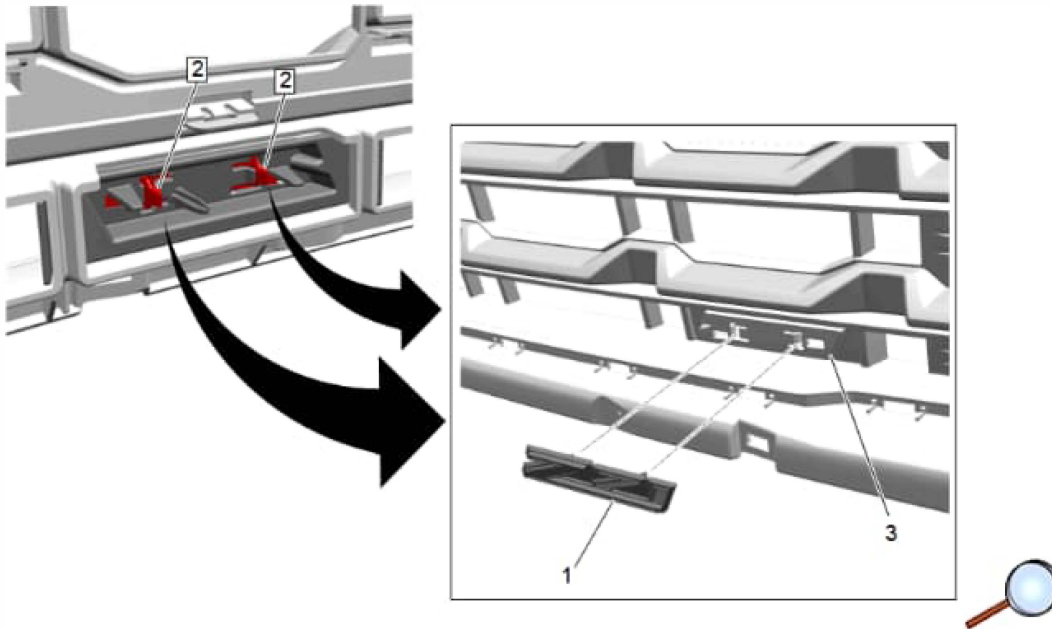

3. Using a suitable flat-bladed tool, release the two locking tabs (2) and remove the front grille Z71 emblem (1) from the front grille emblem housing (3).
4. Accurately position the Z71 emblem (1) to the grille emblem housing (3) and apply pressure to engage the retention tabs (2).
5. Verify that the emblem is fully seated and securely attached to the grille emblem housing.

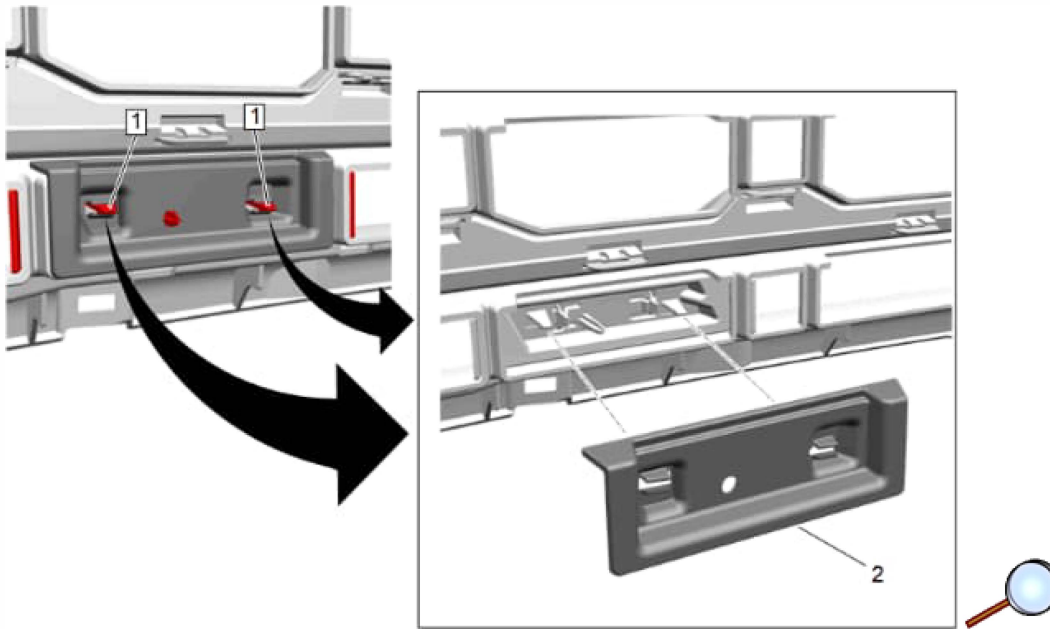

6. Accurately position the retainer (2) to the grille emblem housing and apply pressure to engage the retention tabs (1).
7. Verify that the retainer and grille emblem housing is fully seated and securely attached to the grille.
8. Re-install the front grille. Refer to [Front Grille Replacement](#) in Vehicle Service Manual.

**Grille Nameplate (ZR2)**

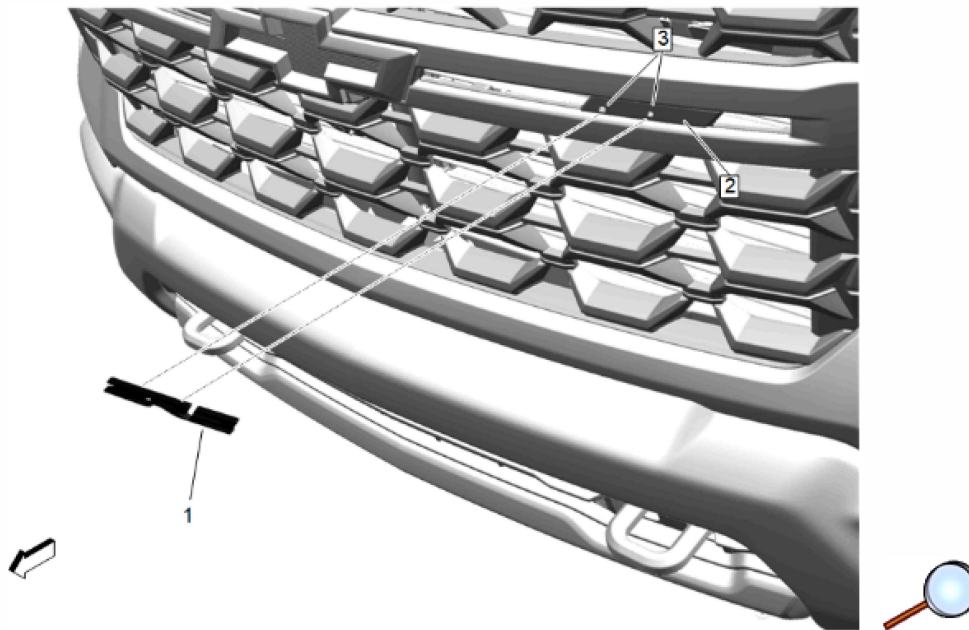

1. Using a suitable plastic flat-bladed tool, remove the front grille ZR2 emblem (1) from the front grille (2).
2. Using 3M® general purpose Adhesive Cleaner (P/N 08984), wipe the area where the nameplate will be installed. Wipe surface dry with a clean lint-free towel.
3. Peel the protective liner from the adhesive backing. Be careful not to touch the tape with hands and do not allow tape to come in contact with dirt or any foreign matter prior to adhesion.
4. Accurately position the ZR2 emblem (1) to the grille (2) by lining up the two guide pins to grill holes (3).
5. Using the palm of the hand or an applicable roller with approximately 10 lbs of pressure, wet out the emblem/name plate to the mating surface to ensure full adhesion of the nameplate is made.
6. Verify that the emblem is fully seated and securely attached to the grille.

## Body Nameplates Without ZR2

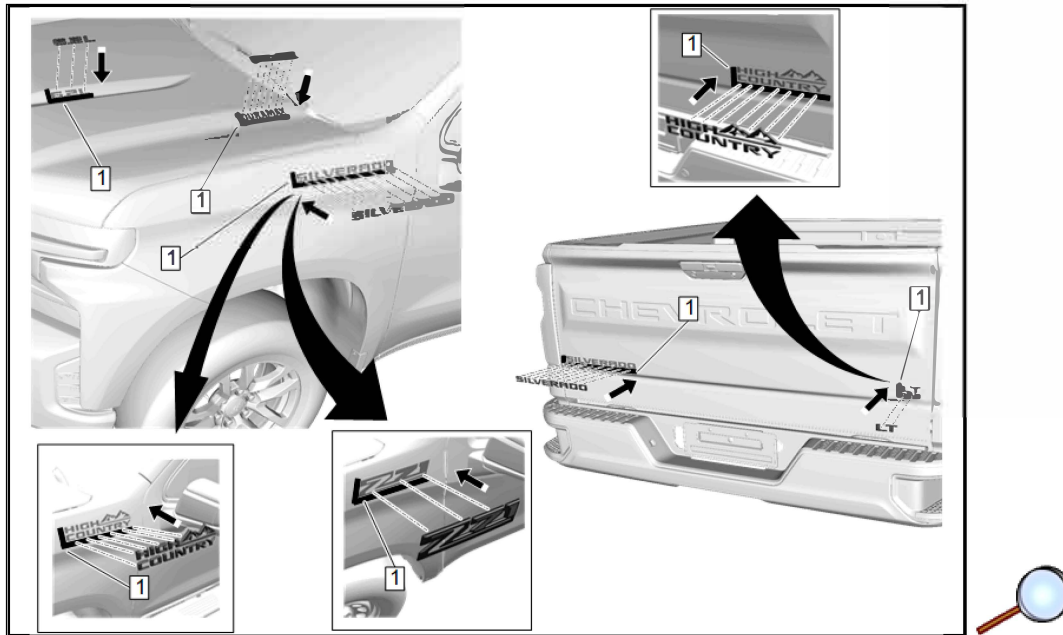

## Body Nameplates With ZR2

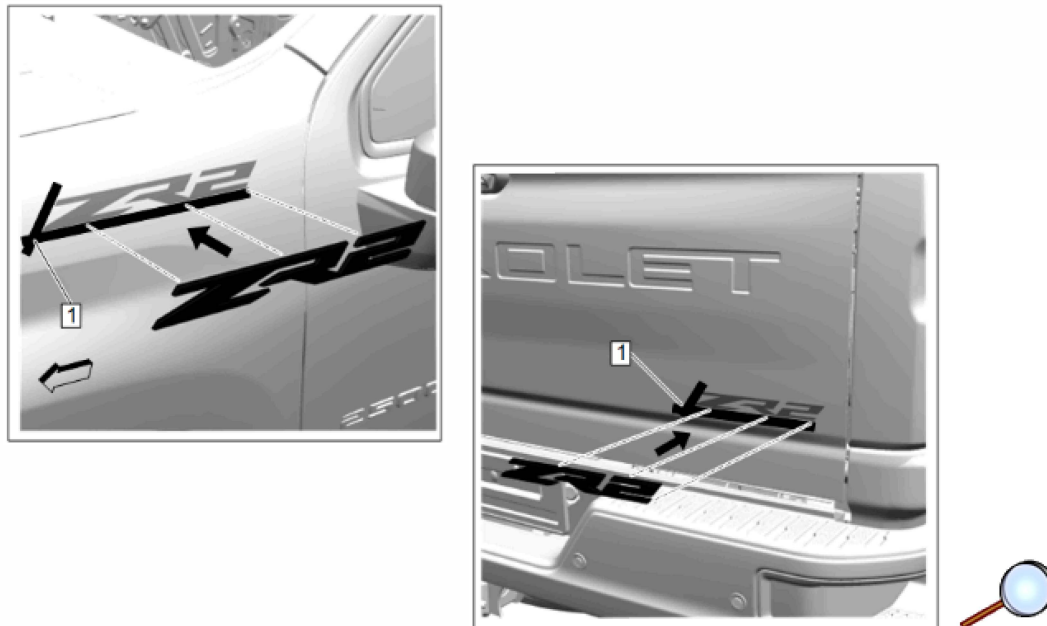

## Body Nameplates Procedure

**Caution:** Only install black nameplates as a direct replacement of the existing vehicle content.

1. Apply masking tape (1) around existing nameplates to be replaced. Tape the left side and the bottom edge of the existing nameplate. This will be the locating feature for the new accessory nameplate.
2. Use a suitable plastic flat-bladed tool to remove the chrome nameplate.
3. Using 3M® general purpose Adhesive Cleaner (P/N 08984), wipe the area where the nameplate will be installed. Wipe surface dry with a clean lint-free towel.
4. Take one of the nameplates and peel the protective liner from the adhesive backing. Be careful not to touch the tape with hands and do not allow tape to come in contact with dirt or any foreign matter prior to adhesion.
5. **IMPORTANT:** The adhesive will bond quickly to the paint. In the event that the nameplate should be mis-aligned after installation, do not attempt to remove the nameplate as this will cause paint damage. To avoid mis-alignment, do not drop the nameplate into place. Instead, first align the bottom edge of the emblem lettering to the masking tape. Then, toggle the nameplate into place.
6. Using the palm of the hand or an applicable roller with approximately 10 lbs of pressure, wet out the emblem/name plate to the mating surface to ensure full adhesion of the nameplate is made.
7. Repeat the same procedure for the remaining nameplates.

## Silverado Hood Nameplate (TURBOMAX)

### 1. LH Nameplate:

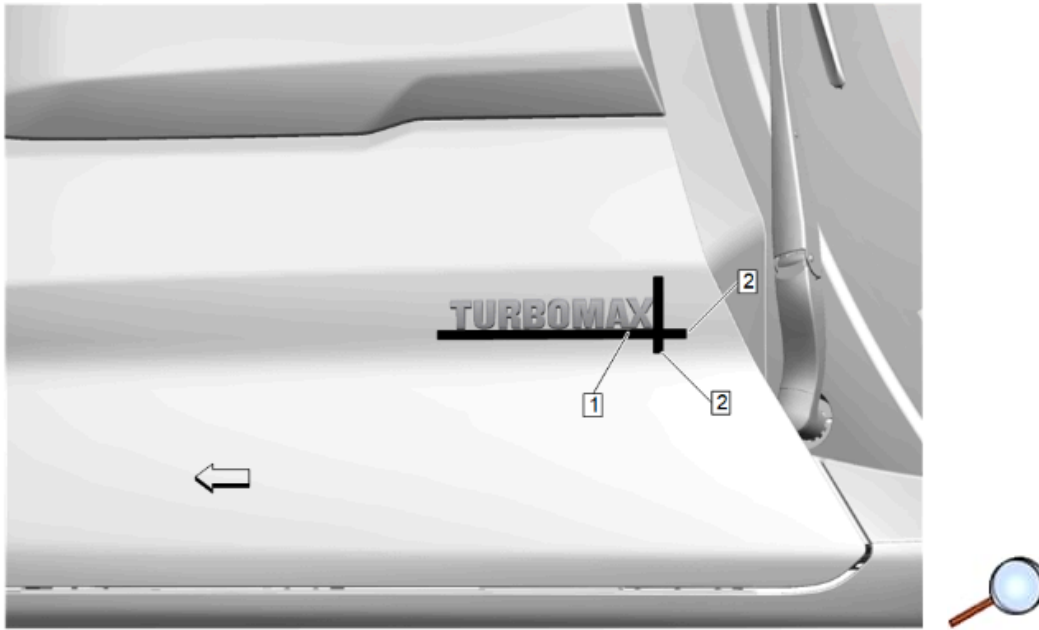

**Caution:** Only install nameplates as a direct replacement of the existing vehicle content.

- 1.1. Apply masking tape (2) around the existing nameplate to be replaced. These will be the locating features for the new accessory nameplate.
- 1.2. Use a plastic flat-bladed tool to remove the nameplate (1).
- 1.3. Using 3M® general purpose Adhesive Cleaner (P/N 08984), wipe the area where the nameplate will be installed. Wipe surface dry with a clean lint-free towel.



- 1.4. Carefully cut out notches (1) as shown in the foam carrier without damaging or misaligning any of the letters. The notches will provide points of reference to help align the bottom of the letters to the tape.
- 1.5. Take the nameplate and peel the protective liner from the adhesive backing on the rear of the nameplate. Be careful not to touch the tape with hands and do not allow the tape to come into contact with dirt or any foreign matter prior to adhesion.

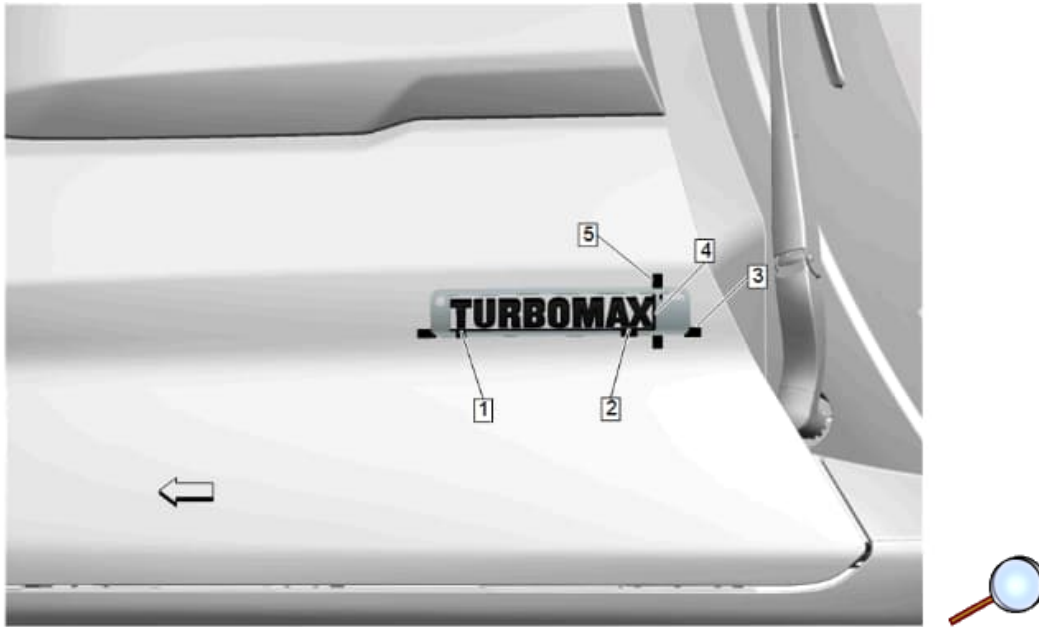

**Note:** Make sure the foam carrier and nameplate stay together during installation.

- 1.6. **IMPORTANT:** The adhesive will bond quickly to the paint. In the event that the nameplate should be misaligned after installation, do not attempt to remove the nameplate as this will cause paint damage. To avoid misalignment, do not drop the nameplate into place. Instead, first align the bottom edge of the "T" (1) and "AX" (2) of the nameplate in foam carrier to the top of masking tape (3). Then, toggle the foam carrier edge (4) to the tape (5).
- 1.7. Using the palm of the hand or an applicable roller with approximately 10 lbs of pressure, wet out the emblem/name plate to the mating surface to ensure full adhesion of the nameplate is made.
- 1.8. Remove the foam carrier and the protective liner from the front of the nameplate.
- 1.9. Remove masking tape.

## 2. RH Nameplate:

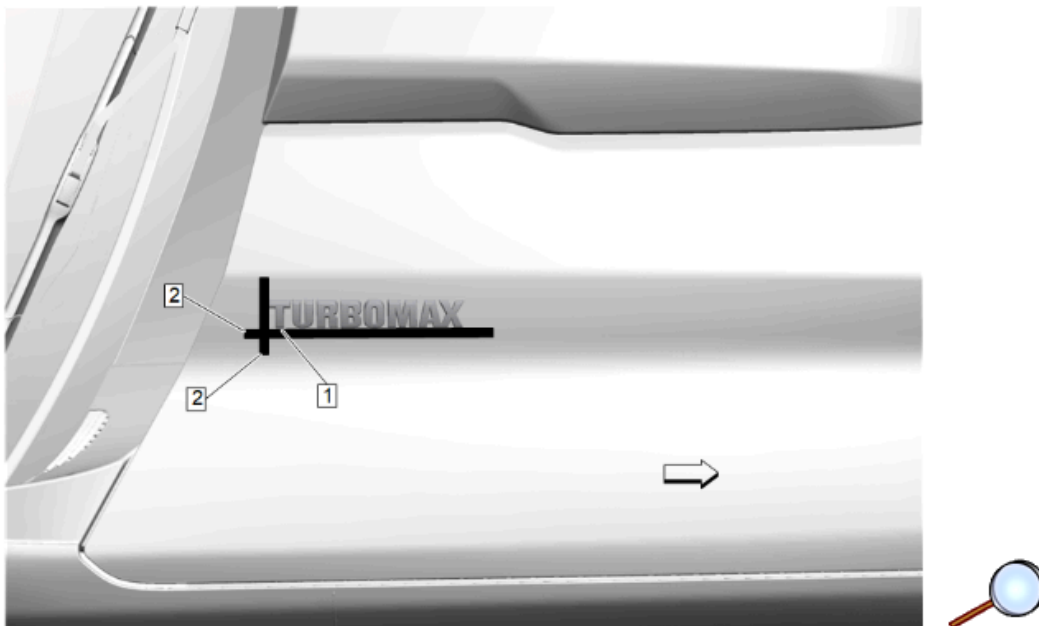

**Caution:** Only install nameplates as a direct replacement of the existing vehicle content.

- 2.1. Apply masking tape (2) around the existing nameplate to be replaced. These will be the locating features for the new accessory nameplate.
- 2.2. Use a plastic flat-bladed tool to remove the nameplate (1).
- 2.3. Using 3M® general purpose Adhesive Cleaner (P/N 08984), wipe the area where the nameplate will be installed. Wipe surface dry with a clean lint-free towel.



- 2.4. Carefully cut out notches (1) as shown in the foam carrier without damaging or misaligning any of the letters. The notches will provide points of reference to help align the bottom of the letters to the tape.
- 2.5. Take the nameplate and peel the protective liner from the adhesive backing on the rear of the nameplate. Be careful not to touch the tape with hands and do not allow the tape to come into contact with dirt or any foreign matter prior to adhesion.

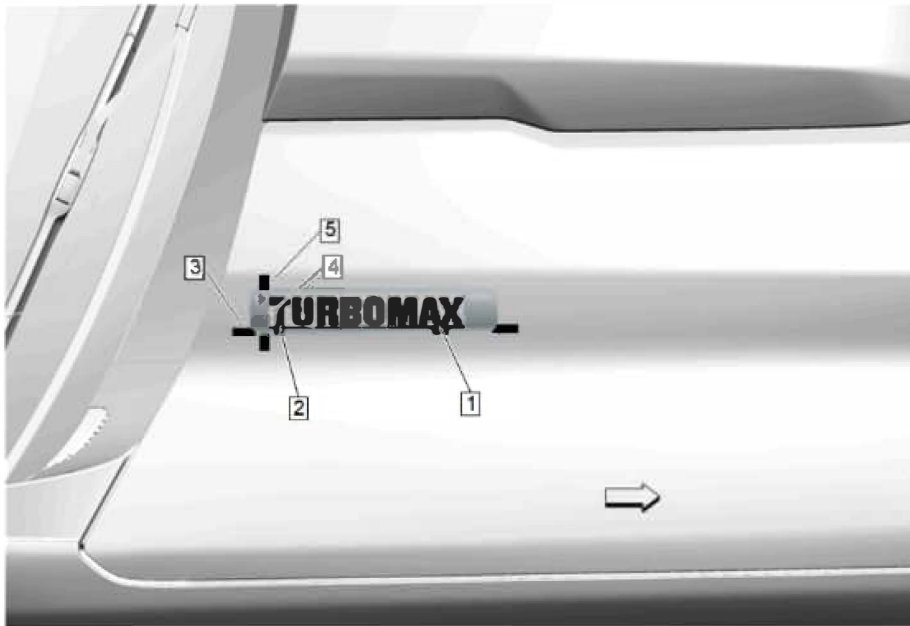

**Note:** Make sure the foam carrier and nameplate stay together during installation.

- 2.6. **IMPORTANT:** The adhesive will bond quickly to the paint. In the event that the nameplate should be misaligned after installation, do not attempt to remove the nameplate as this will cause paint damage. To avoid misalignment, do not drop the nameplate into place. Instead, first align the bottom edge of the "AX" (1) and "T" (2) of the nameplate in foam carrier to the top of masking tape (3). Then, toggle the foam carrier edge (4) to the tape (5).
- 2.7. Using the palm of the hand or an applicable roller with approximately 10 lbs of pressure, wet out the emblem/name plate to the mating surface to ensure full adhesion of the nameplate is made.
- 2.8. Remove the foam carrier and the protective liner from the front of the nameplate.
- 2.9. Remove masking tape.

## Colorado Hood Nameplate (TURBOMAX)

### 1. LH Nameplate:

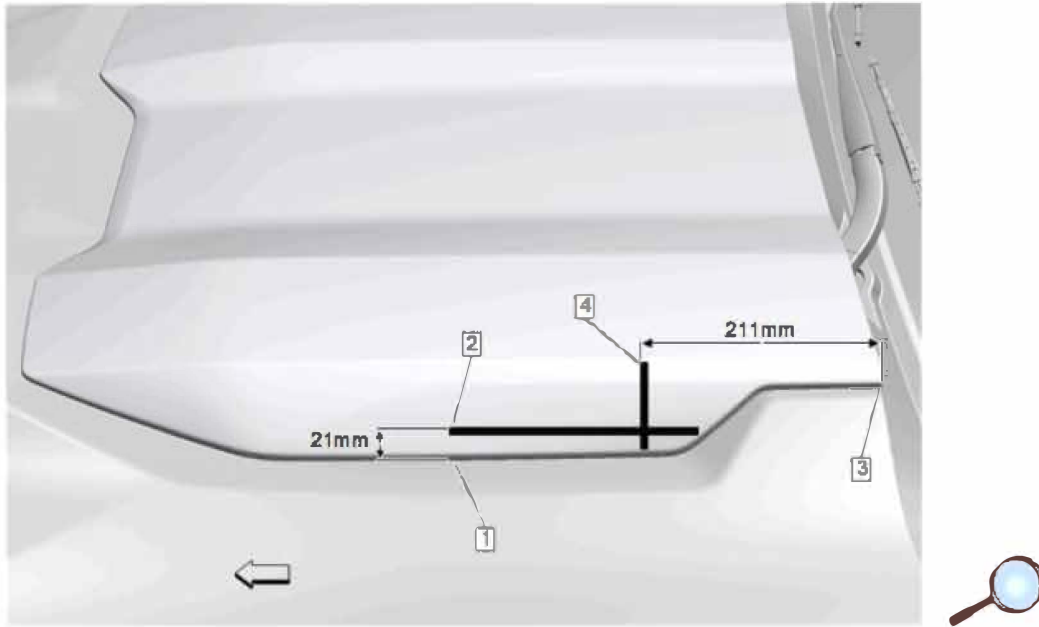

- 1.1. Starting from the bottom of hood molding (1) measure 21mm and apply a piece of masking tape (2) horizontally as shown. Starting from the rear of the hood molding (3), measure 211 mm and apply a piece of masking tape (4) vertically as shown. These will be the locating features for the new accessory nameplate.
- 1.2. Using 3M® general purpose Adhesive Cleaner (P/N 08984), wipe the area where the nameplate will be installed. Wipe surface dry with a clean lint-free towel.

© 2025 General Motors. All rights reserved.



- 1.3. Carefully cut out notches (1) as shown in the foam carrier without damaging or misaligning any of the letters. The notches will provide points of reference to help align the bottom of the letters to the tape.
- 1.4. Take the nameplate and peel the protective liner from the adhesive backing on the rear of the nameplate. Be careful not to touch the tape with hands and do not allow the tape to come into contact with dirt or any foreign matter prior to adhesion.

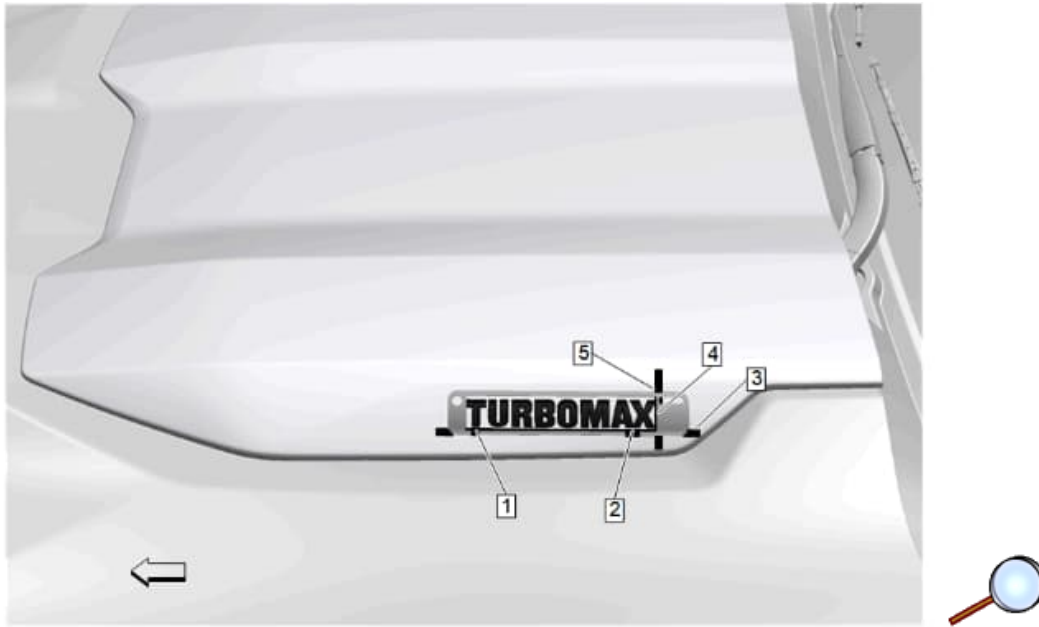

**Note:** Make sure the foam carrier and nameplate stay together during installation.

- 1.5. **IMPORTANT:** The adhesive will bond quickly to the paint. In the event that the nameplate should be misaligned after installation, do not attempt to remove the nameplate as this will cause paint damage. To avoid misalignment, do not drop the nameplate into place. Instead, first align the bottom edge of the "T" (1) and "AX" (2) of the nameplate in foam carrier to the top of masking tape (3). Then, toggle the foam carrier edge (4) to the tape (5).
- 1.6. Using the palm of the hand or an applicable roller with approximately 10 lbs of pressure, wet out the emblem/name plate to the mating surface to ensure full adhesion of the nameplate is made.
- 1.7. Remove the foam carrier and the protective liner from the front of the nameplate.
- 1.8. Remove masking tape.

## 2. RH Nameplate:

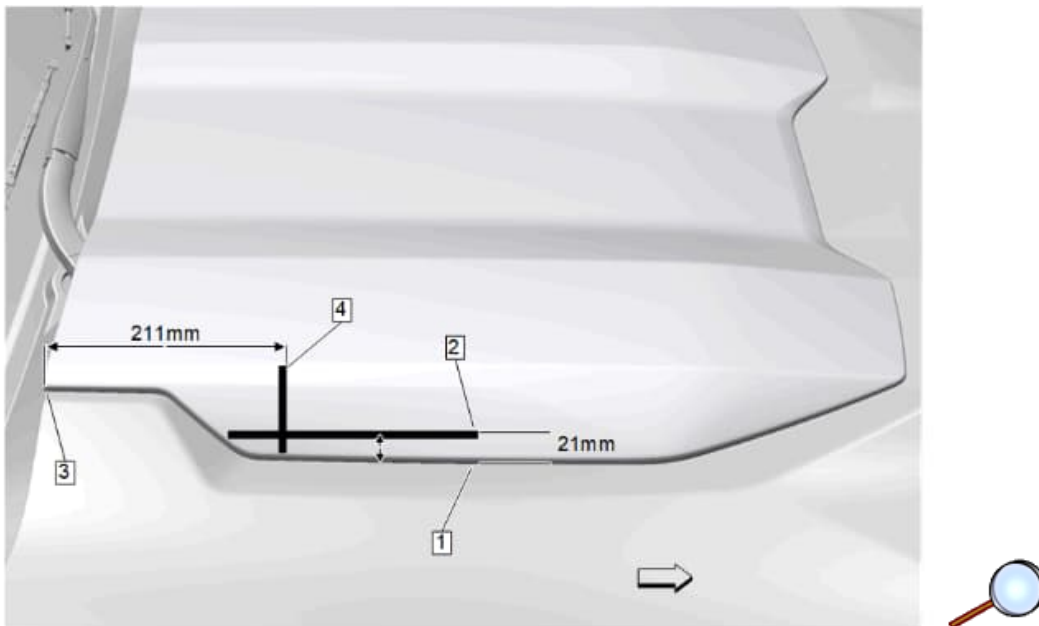

- 2.1. Starting from the bottom of hood molding (1) measure 21mm and apply a piece of masking tape (2) horizontally as shown. Starting from the rear of the hood molding (3), measure 211 mm and apply a piece of masking tape (4) vertically as shown. These will be the locating features for the new accessory nameplate.
- 2.2. Using 3M® general purpose Adhesive Cleaner (P/N 08984), wipe the area where the nameplate will be installed. Wipe surface dry with a clean lint-free towel.



- 2.3. Carefully cut out notches (1) as shown in the foam carrier without damaging or misaligning any of the letters. The notches will provide points of reference to help align the bottom of the letters to the tape.
- 2.4. Take the nameplate and peel the protective liner from the adhesive backing on the rear of the nameplate. Be careful not to touch the tape with hands and do not allow the tape to come into contact with dirt or any foreign matter prior to adhesion.

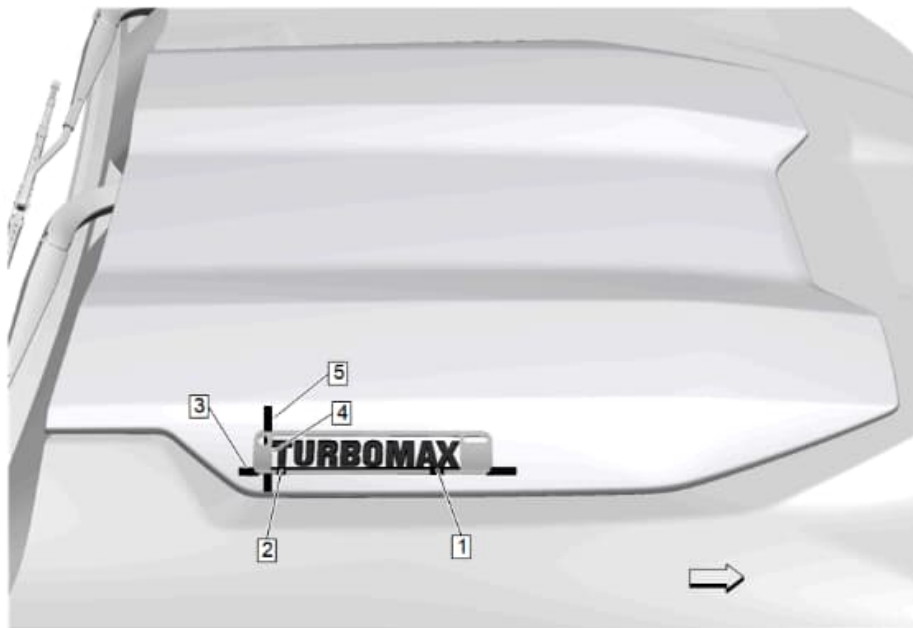

**Note:** Make sure the foam carrier and nameplate stay together during installation.

- 2.5. **IMPORTANT:** The adhesive will bond quickly to the paint. In the event that the nameplate should be misaligned after installation, do not attempt to remove the nameplate as this will cause paint damage. To avoid misalignment, do not drop the nameplate into place. Instead, first align the bottom edge of the "AX" (1) and "T" (2) of the nameplate in foam carrier to the top of masking tape (3). Then, toggle the foam carrier edge (4) to the tape (5).
- 2.6. Using the palm of the hand or an applicable roller with approximately 10 lbs of pressure, wet out the emblem/name plate to the mating surface to ensure full adhesion of the nameplate is made.
- 2.7. Remove the foam carrier and the protective liner from the front of the nameplate.
- 2.8. Remove masking tape.