

# Body Emblem Package Installation

## Installation Instructions Part Number

84188541

### Kit Contents

Qty	Description
1	Emblem (Liftgate) – “BLAZER”
1	Emblem (Liftgate) – “AWD”
1	Emblem (Liftgate) – “PREMIER”
2	Emblem (Door) – “BLAZER”
1	Installation Instructions

### Tools Required

Masking Tape

Rubber Roller

Scissors

Plastic Flat Bladed Tool

### Before you start

**Note:** For the nameplate to adhere best, the vehicle’s mating surface (doors, rear compartment, etc.) should be free of damage (dents, scratches, creases, fractures, etc.).

**Caution:** Do not use heat gun/hair dryer or apply excessive heat to the emblem/nameplate as this may damage the paint and surrounding panel surfaces during removal.

**Caution:** Use a plastic, flat-bladed tool to prevent paint damage when removing an emblem/nameplate. Do not use fishing line to remove nameplate as this may worsen the tape residue cleaning process. Use Isopropyl Alcohol and Lint Free Cloth to remove tape residue. Heavy foam/adhesive residue remaining on the painted surface can be removed using 3M’s Scotch-Brite™ Molding Adhesive and Stripe Removal 4-inch Foam Disc.

**Caution:** Only install nameplates as a direct replacement of the existing vehicle content.

1. The part and surface should be 21°C (70°F) prior to installation. The vehicle should remain 21°C (70°F) for one hour after assembly to allow adhesive to develop sufficient bond strength.
2. Wash the vehicle mating surfaces (Door or Liftgate) with a non-petroleum based cleaning product. If a stronger cleaner is required to remove any contaminates, use 3M general purpose Adhesive Cleaner (P/N 08984). Then, thoroughly dry with a soft clean cloth.

## Procedure

**Caution:** Only install black badges as a direct replacement of the existing vehicle content.

1. Apply masking tape around existing nameplates to be replaced. Tape the left side and the bottom edge of the existing nameplate. This will be the locating feature for the new Accessory emblem.
2. Starting on the rear liftgate, use a plastic flat-bladed tool and finger pulling method to remove adhesively attached chrome "BLAZER" nameplate.
3. Using a non-petroleum based cleaning product, wipe the area of the liftgate or door where the emblem will be installed. Wipe surface dry with a clean lint-free towel.
4. Take one of the "BLAZER" emblems and peel the protective liner from the adhesive backing. Be careful not to touch the tape with hands and do not allow tape to come in contact with dirt or any foreign matter prior to adhesion.
5. **IMPORTANT:** The adhesive will bond quickly to the paint. In the event that the emblem should be mis-aligned after installation, do not attempt to remove the emblem as this will cause paint damage. To avoid mis-alignment, do not drop the emblem into place. Instead, first align the bottom edge of the emblem lettering to the masking tape. Then, toggle the emblem into place.
6. Using the palm of the hand or an applicable roller with approximately 10 lbs of pressure, wet out the emblem/name plate to the mating surface to ensure full adhesion of the nameplate is made.
7. Repeat the same procedure for the remaining emblems: AWD or PREMIER (if applicable).

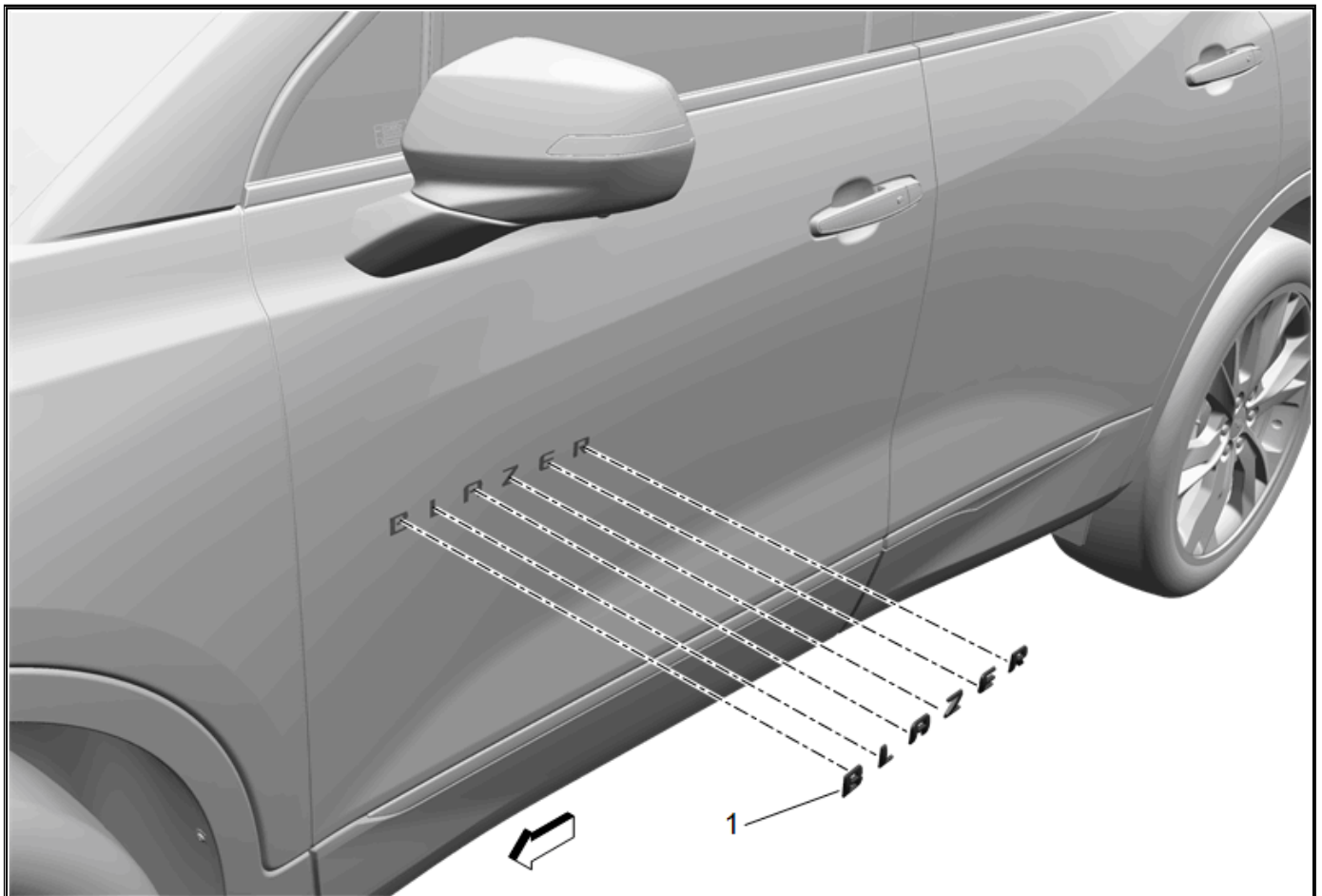

### 7.1. Door emblem ("BLAZER") (1).

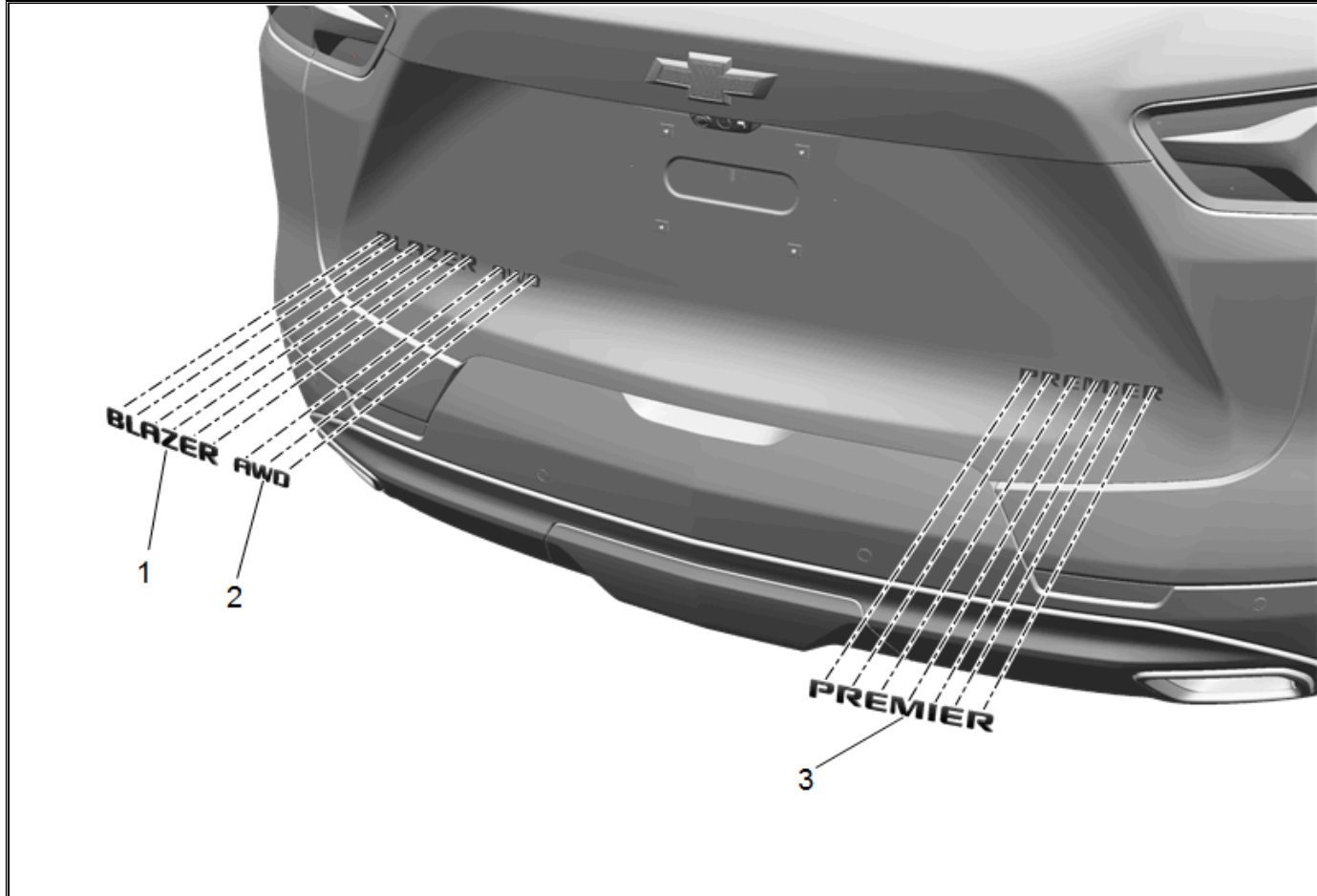

7.2. Rear emblem ("BLAZER") (1).

7.3. Rear emblem ("AWD") (2).

7.4. Rear emblem ("PREMIER") (3).