

# Front Tow Hook Package Installation

## Installation Instructions Part Number

84195905

### Kit Contents

Qty	Description
2	Tow hook
2	Bolt P/N 11589273
2	Bolt P/N 11610915
2	Nut P/N 11549169
1	Installation Instructions

### Special Tools

- EN-45059 Angle Meter

Equivalent regional tools: [Special Tools](#)

### Removal Procedure

**Note:** Step 1 applies to vehicles equipped with ZR2 only. For non ZR2 equipped vehicles, continue to step 2.

1. Remove the front bumper impact bar, **if equipped with ZR2 only**. Refer to [Front Bumper Impact Bar Removal and Installation](#) in Vehicle Service Installation Manual.

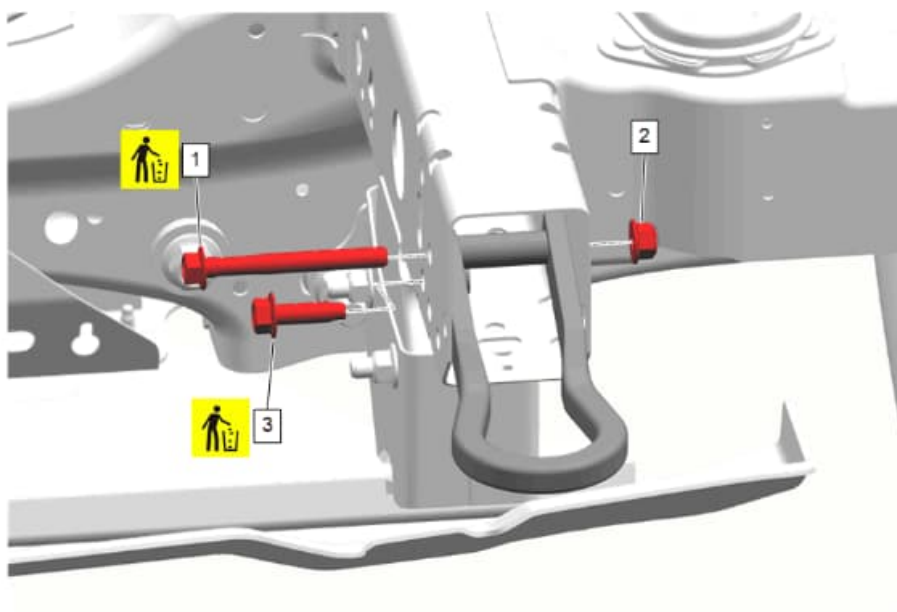

**Note:** Some components not shown for graphic clarity.

2. Remove the front tow hook nut (2) and discard.
3. Remove front tow hook bolt (1) from tow hook and discard bolt.
4. Remove front tow hook bolt (3) from tow hook and discard bolt.

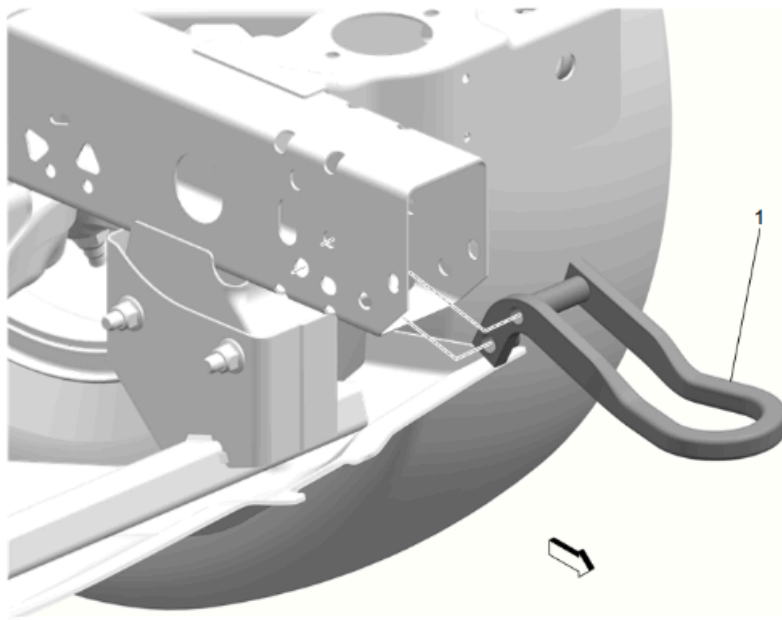

- Note:** Some components not shown for graphic clarity.
5. Remove front tow hook (1).
  6. Repeat steps 2 through 5 for opposite side.

[Installation Procedure](#)

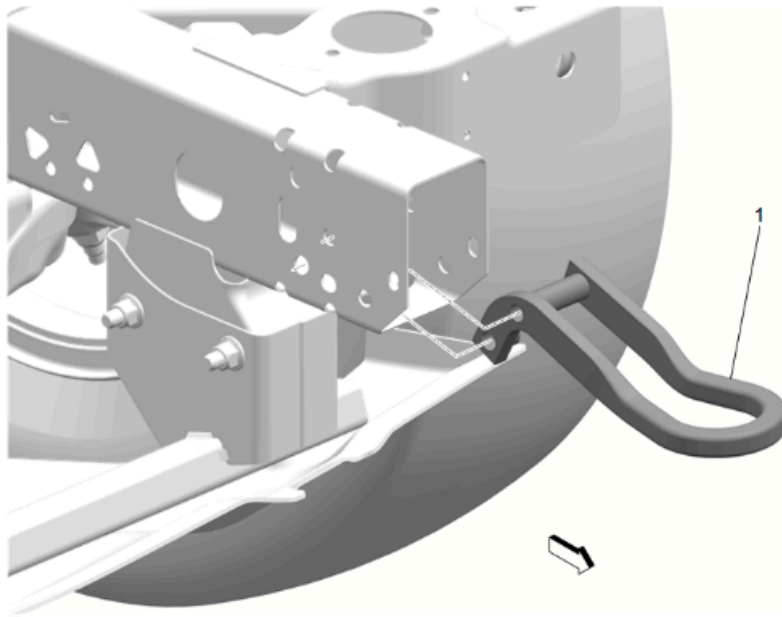

- Note:** Some components not shown for graphic clarity.
1. Install front tow hook (1).

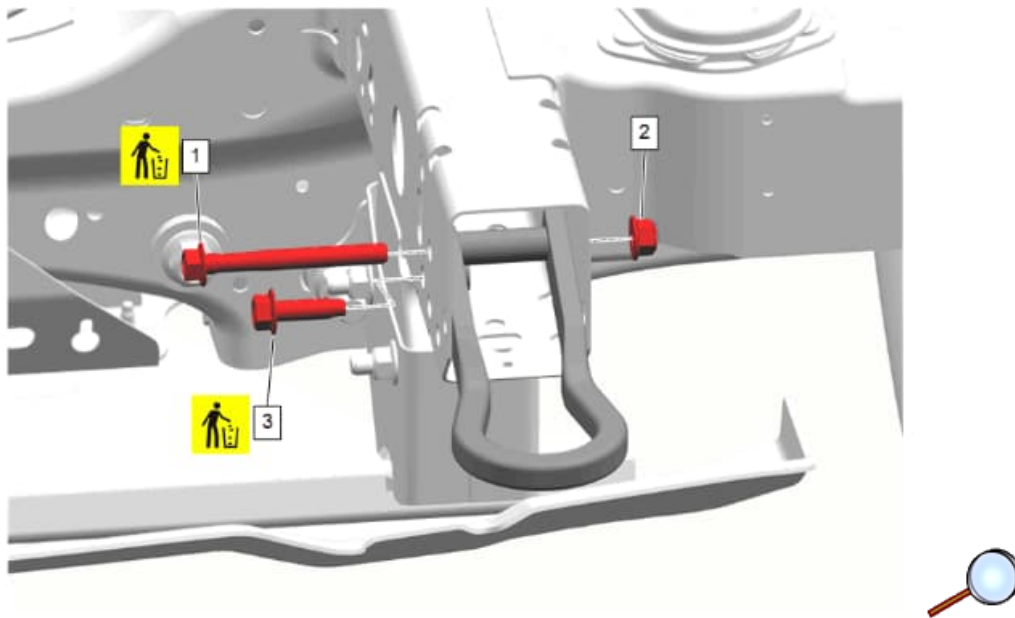

**Note:** Some components not shown for graphic clarity.

**Caution:** Refer to [Fastener Caution](#).

2. Install new front (short) tow hook bolt (3).
3. Install new (long) front tow hook bolt (1).
4. Install new front tow hook nut (2). Hand tighten.

**Caution:** This vehicle is equipped with torque-to-yield or single use fasteners. Install a NEW torque-to-yield or single use fastener when installing this component. Failure to replace the torque-to-yield or single use fastener could cause damage to the vehicle or component.

5. Front Tow Hook Bolt (3), tighten:
  - 5.1. First Pass: **75N•m (55 lb ft)**
  - 5.2. Final Pass: **60 - 75 degrees**, using the *EN-45059* Angle Meter

**Caution:** This vehicle is equipped with torque-to-yield or single use fasteners. Install a NEW torque-to-yield or single use fastener when installing this component. Failure to replace the torque-to-yield or single use fastener could cause damage to the vehicle or component.

6. Front Tow Hook Bolt (1), tighten:
  - 6.1. First Pass: **75N•m (55 lb ft)**
  - 6.2. Final Pass: **90 - 105 degrees**, using the *EN-45059* Angle Meter

7. Repeat steps 1 through 6.2, for opposite side.

**Note:** Step 8 applies to vehicles equipped with ZR2 only.

8. Install the front bumper impact bar, **if equipped with ZR2 only**. Refer to [Front Bumper Impact Bar Removal and Installation](#) in Vehicle Service Installation Manual.