



ACCESSORIES

Cadillac CT5 Splash Guard - Rear

Please read instructions thoroughly before starting.

Tools Required

- T15 Torx Screw Driver
- Drill with 1/4" (6.35 mm) Drill Bit
- Clean Cloth/Rag

Parts Required from Package Contents

Description	Quantity
Left Hand Splash Guard	1
Right Hand Splash Guard	1
Left Hand Bracket	1
Right Hand Bracket	1
M4.2 x 25 Screw	6
M4.2 x 20 Screw	4
M4.2 U-Nut	4
Alcohol Prep-Wipes	2

Rear Installation Procedure

Note: Do not use power tools to install splash guard fasteners

1. Remove tire.
2. Clean and degrease body panel where splash guards are to be located.
3. Using supplied alcohol wipes, clean area where tape makes contact to body.
4. Remove existing screws at location (A) and (C) and discard. **See figure 1.**

See figure 1.

5. Place supplied bracket against wheel liner, install supplied M4.2 x 25 screws in locations (A) and (C) and drill 1/4" (6.35mm) hole at location (B). Hole should be drilled through bracket and wheel liner. **See figure 2.**

6. Uninstall bracket from vehicle. Place supplied u-nuts onto bracket at locations (B) and (D). **See figure 3.**

7. Reinstall bracket against wheel liner and install supplied M4.2 x 25 screw in location (A) and (C) **See figure 2.**

8. Remove fasteners at locations (E) and (F) and discard. **See figure 4.**

9. Place splash guard to vehicle taking care to remove any gaps to the vehicle and making sure tape pull tab is visible. Install supplied M4.2 x 20 screws at location (B) and (D). **See figure 5.**

10. While pulling splash guard rearward and inboard to insure no gaps, Install supplied M4.2 x 25 screw in location (E). **See figure 6.**

11. Remove tape pull tab and apply firm pressure to the splash guard along the tape line to adhere the tape to the fascia. Hold the firm pressure for a minimum of 60 seconds to properly adhere the tape. **See figure 6.**

12. Repeat for other side.

13. Guards can be cleaned with any commercially available cleaner.

NOTE: Max torque on M4.2 Screw is 3.0 N m

Figure 1

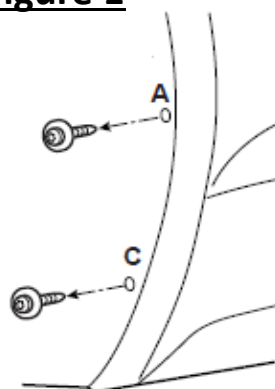

Figure 2

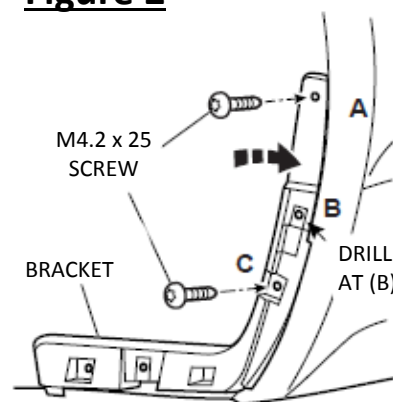

Figure 3

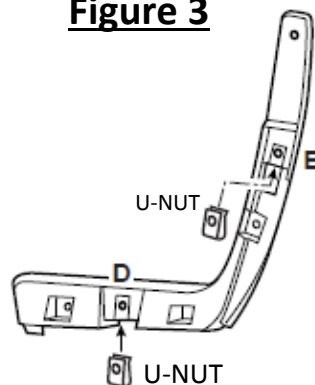

Figure 4

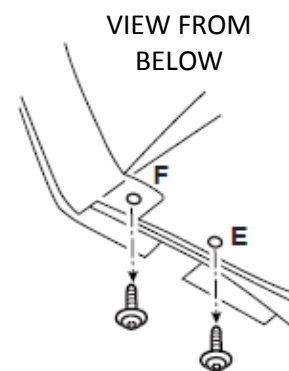

Figure 5

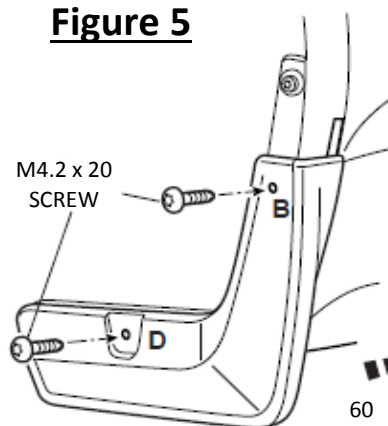
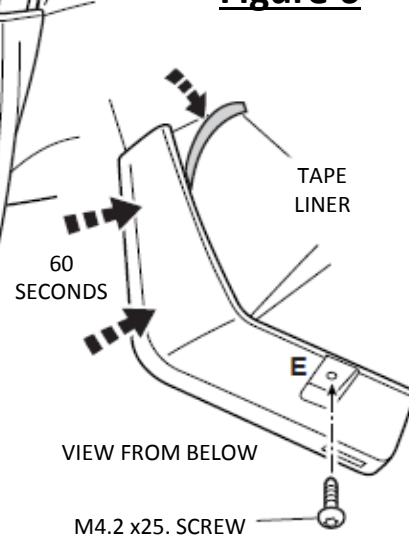

Figure 6



Painted Accessory Mud Guard

IR 09MY19

PART No.

84227717

SHEET

1 of 3

ALL INFORMATION WITHIN ABOVE BORDER TO BE PRINTED EXACTLY AS SHOWN ON 8.5 x 11 WHITE 16 POUND NON-BOND RECYCLABLE PAPER. PRINT ON BOTH SIDES. EXCLUDING TEMPLATES. TO BE UNITIZED IN ACCORDANCE WITH GMCCA SPECIFICATIONS.

Date	Revision	Auth	DR
09MY19	Init Rel Michael Erickson	3041097	

Title Installation Instructions
Painted Accessory Mud Guard

PART No. 84227717

SHEET 1 of 3

ACCESSORIES

French

Bavette garde-boue Cadillac CT5 - Arrière

Lire attentivement les directives avant de commencer.

Outils nécessaires

- Tournevis Torx T15
- Perceuse et foret de 1/4" (6,35 mm)
- Chiffon propre

Pièces nécessaires du contenu de la trousse

Description	Quantité
Bavette garde-boue côté gauche	1
Bavette garde-boue côté droit	1
Support gauche	1
Support droit	1
Vis M4.2 x 25	6
Vis M4.2 x 20	4
Écrou en U M4.2	4
Tampons imbibés d'alcool	2

Procédure de pose arrière

Remarque : Ne pas utiliser d'outils électriques pour la pose des fixations de la bavette garde-boue

- Déposer le pneu.
 - Nettoyer et dégraisser le panneau de carrosserie où seront posées les bavettes garde-boue.
 - Utiliser les tampons d'alcool fournis pour nettoyer la zone d'adhérence du ruban sur la carrosserie.
 - Déposer les vis existantes des emplacements (A) et (C), puis les jeter. **Voir la figure 1.**
 - Placer le support fourni contre la doublure de roue, poser les vis M4.2 x 25 aux emplacements (A) et (C), puis percer un trou de 1/4 po (6,35 mm) à l'emplacement (B). Le trou doit être percé à travers le support et la doublure de roue. **Voir la figure 2.**
 - Retirer le support du véhicule. Placer les écrous en U fournis sur le support aux emplacements (B) et (D). **Voir la figure 3.**
 - Remettre le support contre la doublure de roue et poser les vis M4.2 x 25 aux emplacements (A) et (C). **Voir la figure 2.**
 - Retirer les fixations des emplacements (E) et (F), puis les jeter. **Voir la figure 4.**
 - Placer la bavette garde-boue sur le véhicule en prenant soin d'éliminer tous les espaces et en s'assurant que la tirette du ruban adhésif est visible. Poser les vis M4.2 x 20 fournies aux emplacements (B) et (D). **Voir la figure 5.**
 - Tout en tirant la bavette garde-boue vers l'arrière et l'intérieur pour éliminer tous les espaces, poser la vis M4.2 x 25 fournie à l'emplacement (E). **Voir la figure 6.**
 - Retirer la tirette de ruban et appuyer fermement sur la bavette pare-boue le long de la ligne du ruban pour que le ruban adhère au carénage. Maintenir la pression ferme pendant un minimum de 60 secondes pour que la bande adhère correctement. **Voir la figure 6.**
 - Répéter de l'autre côté.
 - Les bavettes garde-boue peuvent être nettoyées avec n'importe quel produit de nettoyage vendu dans le commerce.
- REMARQUE : Le couple de serrage maximal d'une vis M4.2 est 3,0 Nm.**

Figure 1

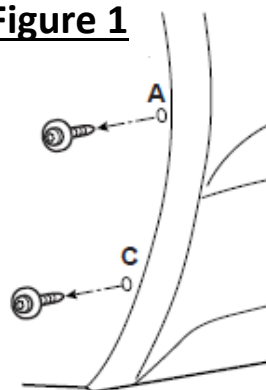

Figure 2

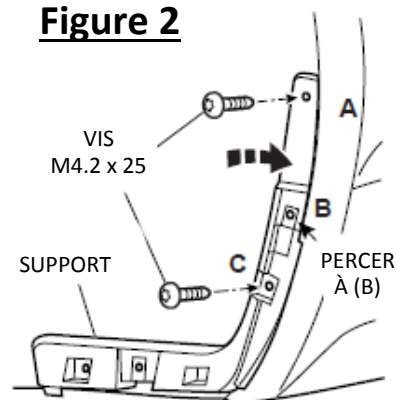

Figure 3

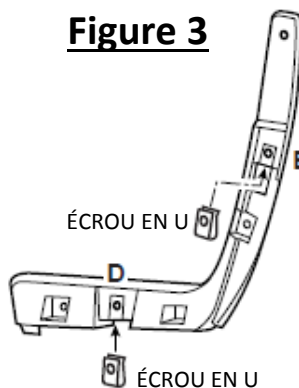

Figure 4

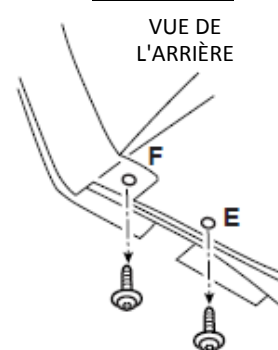

Figure 5

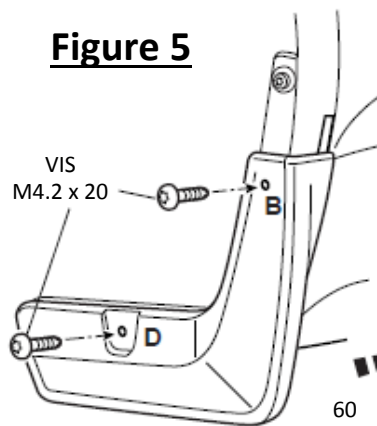
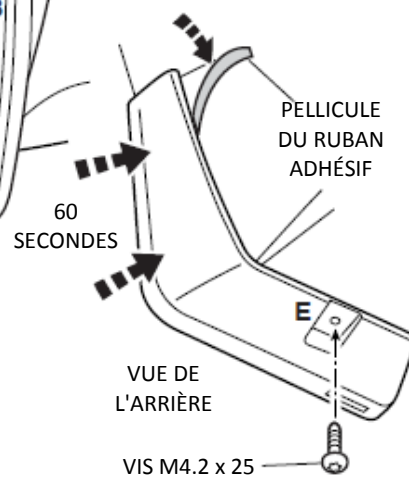

Figure 6



Painted Accessory Mud Guard

IR 09MY19

PART No.

84227717

SHEET

2 of 3

ALL INFORMATION WITHIN ABOVE BORDER TO BE PRINTED EXACTLY AS SHOWN ON 8.5 x 11 WHITE 16 POUND NON-BOND RECYCLABLE PAPER. PRINT ON BOTH SIDES. EXCLUDING TEMPLATES. TO BE UNITIZED IN ACCORDANCE WITH GMCCA SPECIFICATIONS.

Date	Revision	Auth	DR
09MY19	Init Rel Michael Erickson	3041097	

Title Installation Instructions
Painted Accessory Mud Guard

PART No. 84227717

SHEET 2 of 3

ACCESSORIES

Spanish

Salpicadera Cadillac CT5 - Trasera

Por favor lea las instrucciones minuciosamente antes de comenzar.

Herramientas Requeridas

- Destornillador Torx T15
- Taladro con broca de 1/4" (6.35 mm)
- Tela/Estopa Limpia

Partes requeridas del Contenido del paquete

Descripción	Cantidad
Salpicadera izquierda	1
Salpicadera derecha	1
Soporte izquierdo	1
Soporte derecho	1
Tornillo M4.2 x 25	6
Tornillo M4.2 x 20	4
Tuerca U M4.2	4
Toallas preparadas con alcohol	2

Procedimiento de instalación trasera

Nota: No use herramientas eléctricas para instalar los sujetadores de la salpicadera

1. Retire la llanta.
2. Limpie y desengrase el tablero de la carrocería donde se van a ubicar los guardabarros.
3. Utilizando las toallas de alcohol incluidas, limpie el área donde la cinta hace contacto con la carrocería.
4. Retire los tornillos existentes en la ubicación (A) y (C) y deséchelos. **Vea la figura 1.**
5. Coloque el soporte suministrado contra el revestimiento de la rueda, instale los tornillos M4.2 x 25 suministrados en las ubicaciones (A) y (C) y perforo un orificio de 1/4" (6.35mm) en la ubicación (B). El orificio se debe perforar a través del soporte y el revestimiento de la rueda. **Vea la figura 2.**
6. Desinstale el soporte del vehículo. Coloque las tuercas en U suministradas en el soporte en las ubicaciones (B) y (D). **Vea la figura 3.**
7. Vuelva a instalar el soporte contra el revestimiento de la rueda e instale el tornillo M4.2 x 25 suministrado en la ubicación (A) y (C) **Vea la figura 2.**
8. Retire los sujetadores en las ubicaciones (E) y (F) y deséchelos. **Vea la figura 4.**
9. Coloque la salpicadera en el vehículo teniendo cuidado de eliminar cualquier espacio en el vehículo y asegúrese que la lengüeta para jalar de la cinta esté visible. Instale los tornillos M4.2 x 20 incluidos en la ubicación (B) y (D). **Vea la figura 5.**
10. Mientras jala la salpicadera hacia atrás y hacia adentro para asegurarse que no queden huecos, instale el tornillo M4.2 x 25 en la ubicación (E). **Vea la figura 6.**
11. Retire la lengüeta para jalar de cinta y aplique presión firme a la salpicadera a lo largo de la línea de la cinta para adherir la cinta a la facia. Mantenga presión firme por un mínimo de 60 segundos para adherir adecuadamente la cinta. **Vea la figura 6.**
12. Repita para el otro lado.
13. Las protecciones se pueden limpiar con cualquier limpiador disponible comercialmente.

NOTA: Apriete máximo en el tornillo M4.2 es 3.0 Nm

Figura 1



Figura 2



Figura 3

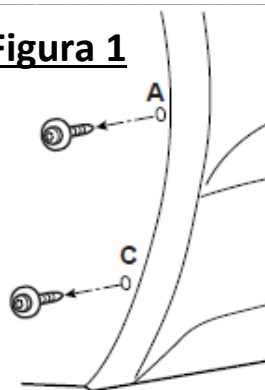

Figura 4

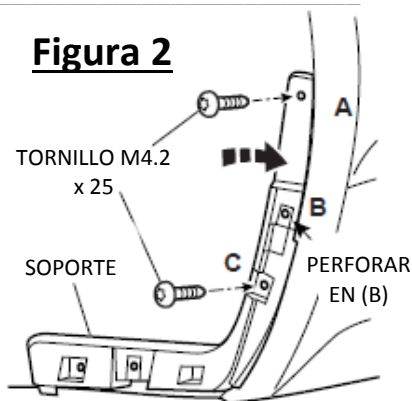

Figura 5

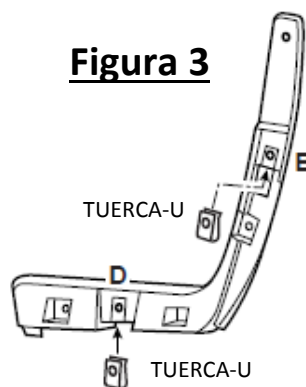

Figura 6

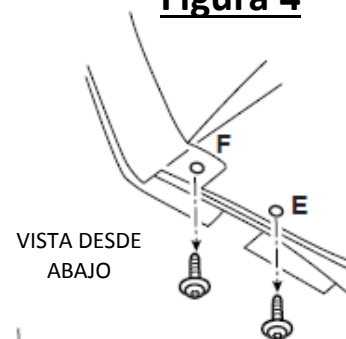

Painted Accessory Mud Guard

IR 09MY19

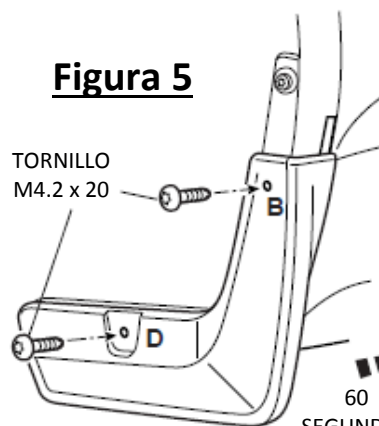
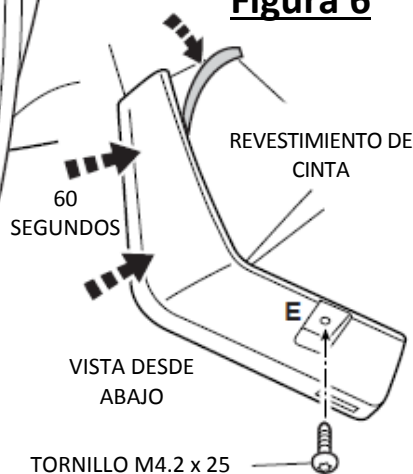
PART No.

84227717

SHEET

3 of 3

ALL INFORMATION WITHIN ABOVE BORDER TO BE PRINTED EXACTLY AS SHOWN ON 8.5 x 11 WHITE 16 POUND NON-BOND RECYCLABLE PAPER. PRINT ON BOTH SIDES, EXCLUDING TEMPLATES. TO BE UNITIZED IN ACCORDANCE WITH GMCCA SPECIFICATIONS.

Date	Revision	Auth	DR
09MY19	Init Rel Michael Erickson	3041097	

Title Installation Instructions
Painted Accessory Mud Guard

PART No. 84227717

SHEET 3 of 3