

Document ID: 5420413

Assist Step Kit Installation

Installation Instructions Part Number

84331836

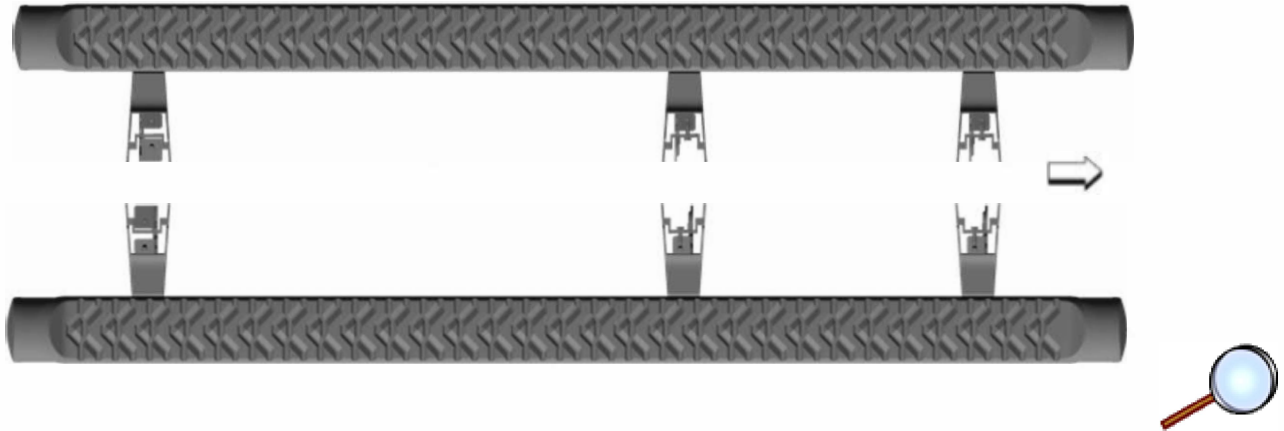

Assist Step Short Wheel Base (SWB)

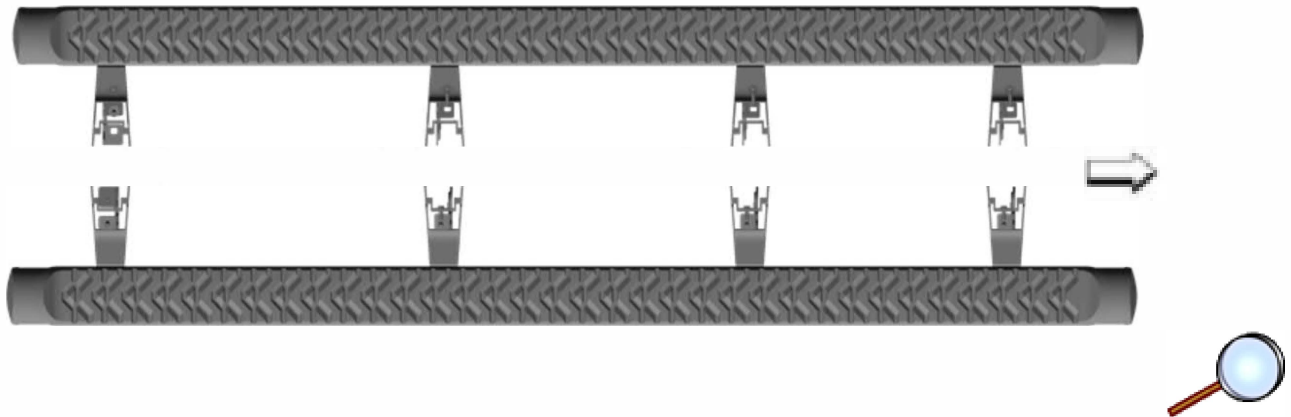

Assist Step Long Wheel Base (LWB)

Kit Contents

Description	SWB Qty:	LWB Qty:
LH Side Tube Assembly	1	1
RH Side Tube Assembly	1	1
M8 Bolt	12	16

Description	SWB Qty:	LWB Qty:
Installation Instructions	1	1

Tools Required

Torque Wrench

13mm Socket

3/8" drive Ratchet

3"3/8" drive extension

Plastic Fastener Removal Tool

Preliminary Procedure

Note: Read entire instructions thoroughly before starting.

Note: Determine left hand and right hand tubular assist steps.

Note: If a customer has a different assist step on their vehicle, or wants their current assist step removed, please ensure all rocker weld nut holes are plugged with retainers (P/N 11589181).

Procedure

Short Wheel Base (SWB) (Driver Side Shown)

1. Raise and support the vehicle. Refer to [Lifting and Jacking the Vehicle](#) in Vehicle Service Manual.

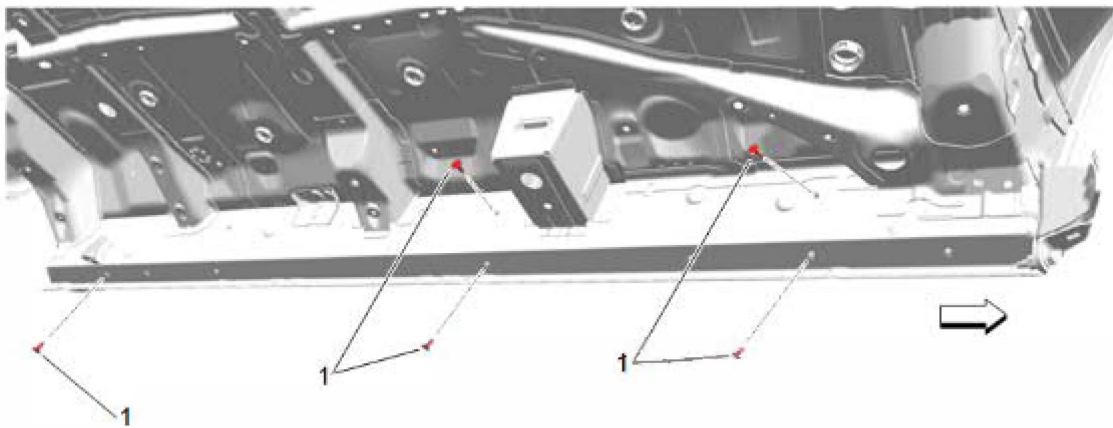

2. Locate and remove the inner retainers (1), five per vehicle side.

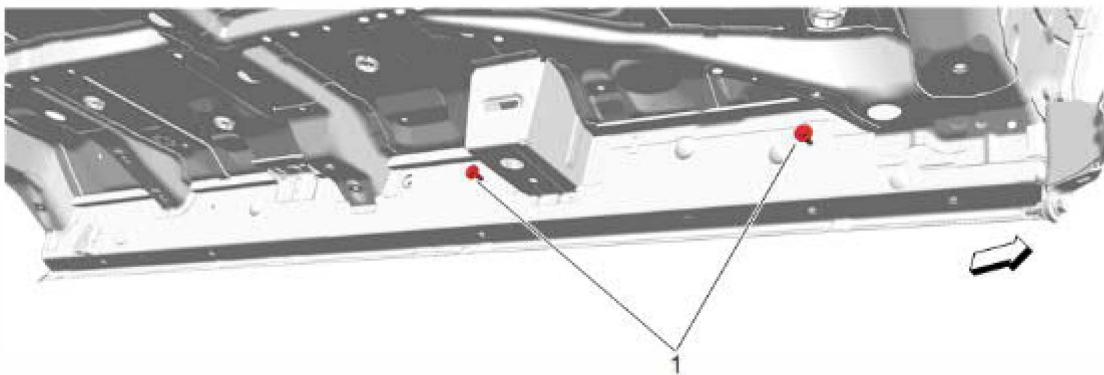

Caution: Use the correct fastener in the correct location. Replacement fasteners must be the correct part number for that application. Fasteners requiring replacement or fasteners requiring the use of thread locking compound or sealant are identified in the service procedure. Do not use paints, lubricants, or corrosion inhibitors on fasteners or fastener joint surfaces unless specified. These coatings affect fastener torque and joint clamping force and may damage the fastener. Use the correct tightening sequence and specifications when installing fasteners in order to avoid damage to parts and systems.

3. Loosely install the top horizontal M8 bolts (1), two per vehicle side.

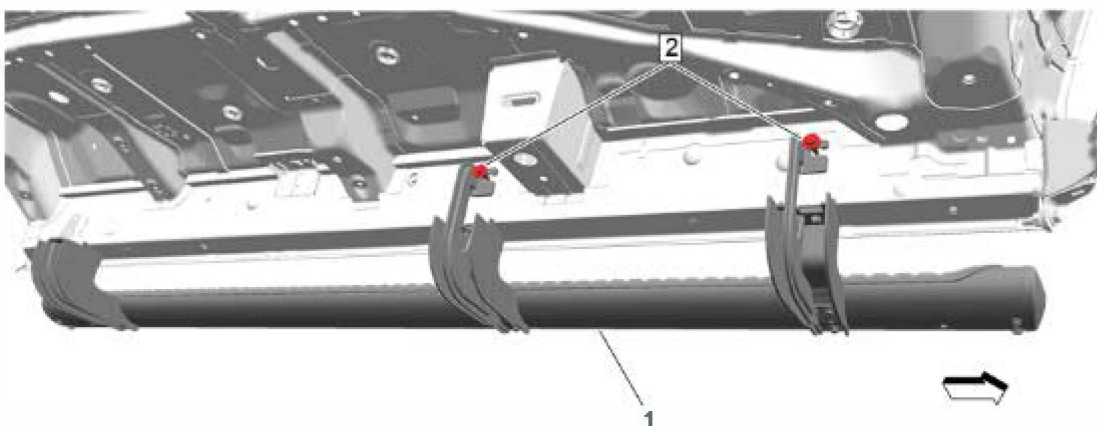

4. Lift and hang assist step assembly (1) from horizontal bolts (2).

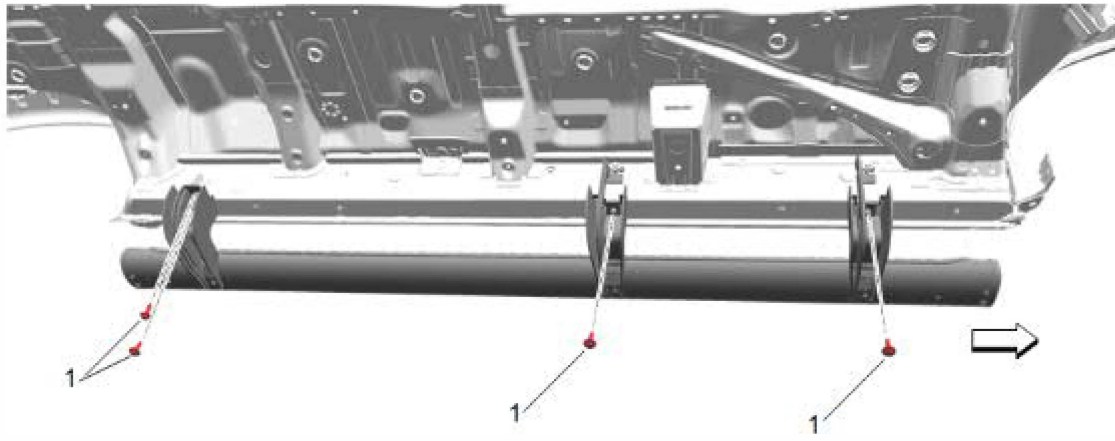

5. Loosely install the bottom vertical M8 bolts (1), four per vehicle side.

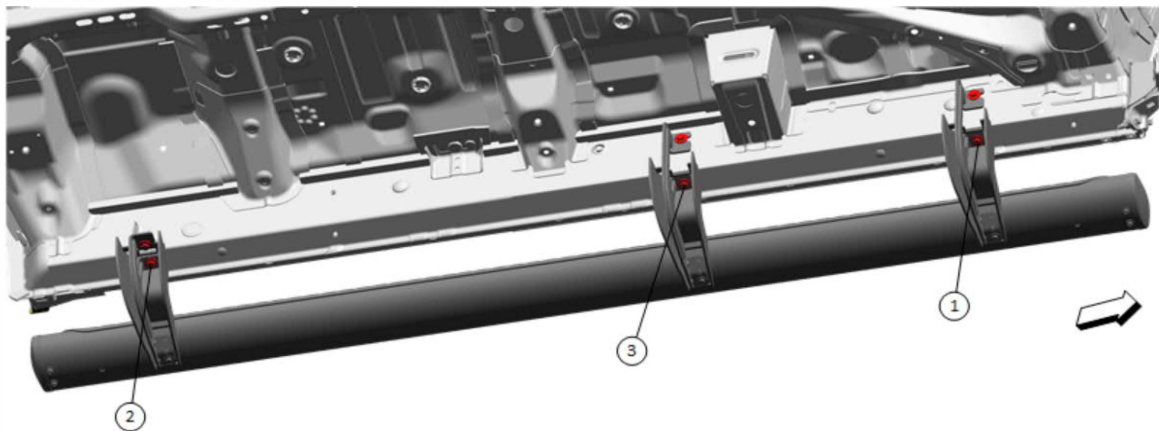

6. Tighten the bottom vertical M8 bolts to **25 N.m (18 lb ft)** according to sequence shown.

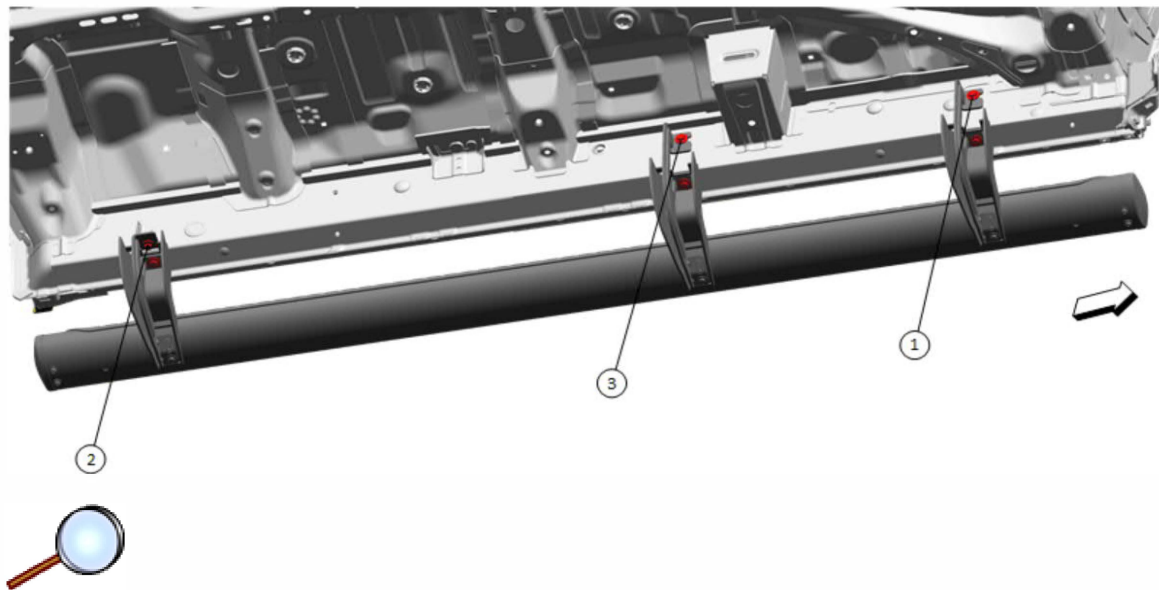

7. Tighten the top horizontal M8 bolts to **25 N.m (18 lb ft)** according to sequence shown.
8. **Verify torque on all hardware.**
9. Repeat steps 2 through 8 for right hand side assist step assembly.
10. Lower the vehicle.

Long Wheel Base (LWB) (Driver Side Shown)

1. Raise and support the vehicle. Refer to [Lifting and Jacking the Vehicle](#) in Vehicle Service Manual.

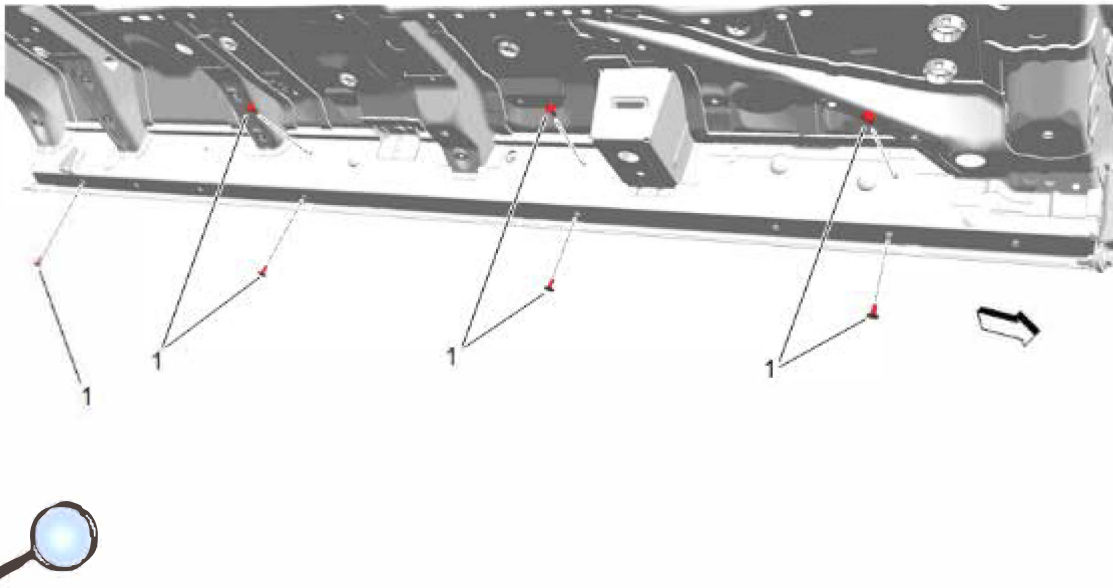

2. Locate and remove the inner retainers (1), seven per vehicle side.

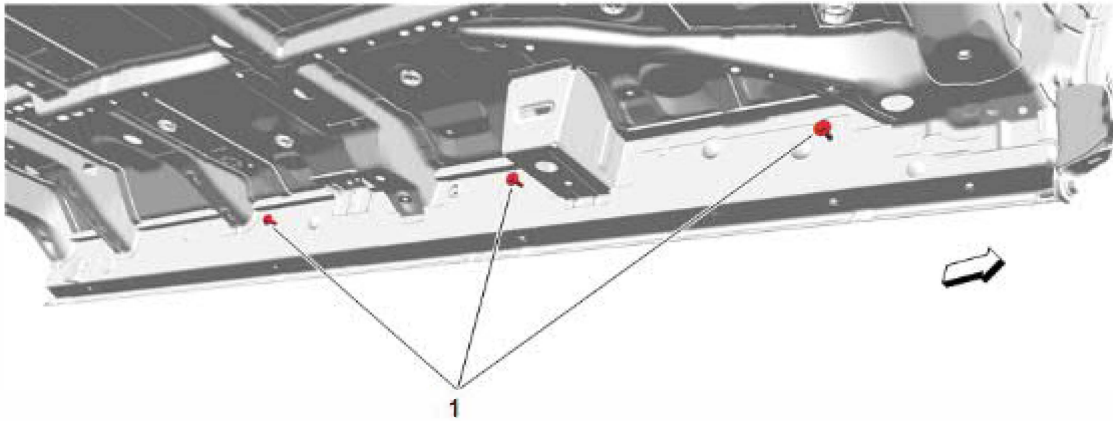

Caution: Use the correct fastener in the correct location. Replacement fasteners must be the correct part number for that application. Fasteners requiring replacement or fasteners requiring the use of thread locking compound or sealant are identified in the service procedure. Do not use paints, lubricants, or corrosion inhibitors on fasteners or fastener joint surfaces unless specified. These coatings affect fastener torque and joint clamping force and may damage the fastener. Use the correct tightening sequence and specifications when installing fasteners in order to avoid damage to parts and systems.

3. Loosely install the top horizontal M8 bolts (1), three per vehicle side.

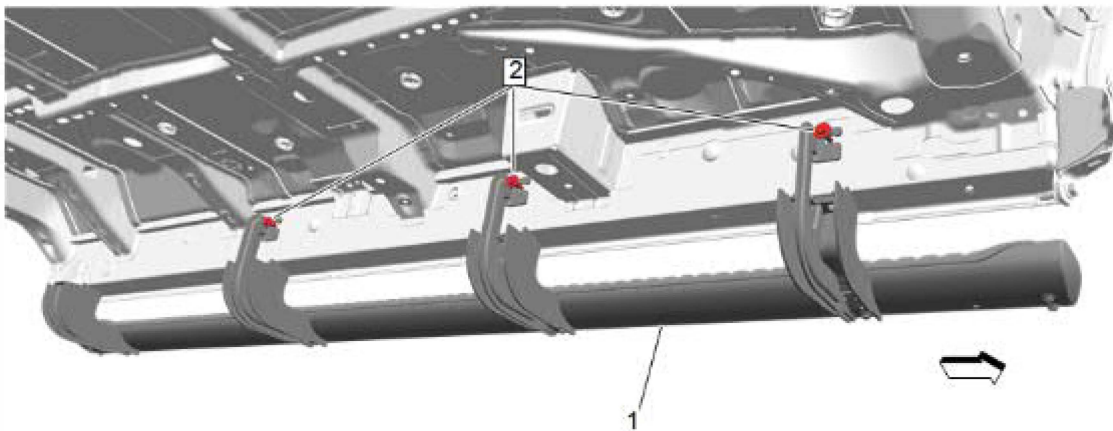

4. Lift and hang assist step assembly (1) from horizontal bolts (2).

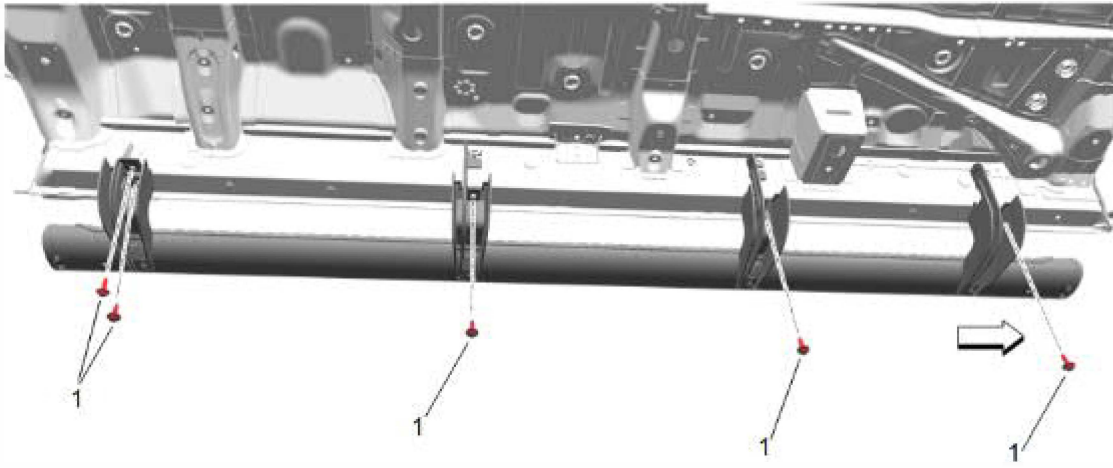

5. Loosely install the bottom vertical M8 bolts (1), five per vehicle side.

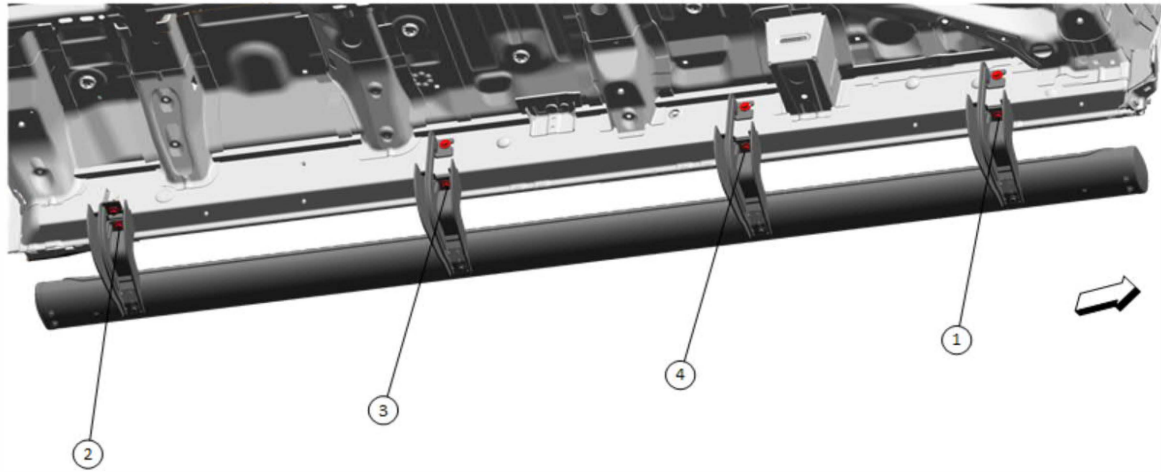

6. Tighten the bottom vertical M8 bolts to **25 N.m (18 lb ft)** according to sequence shown.

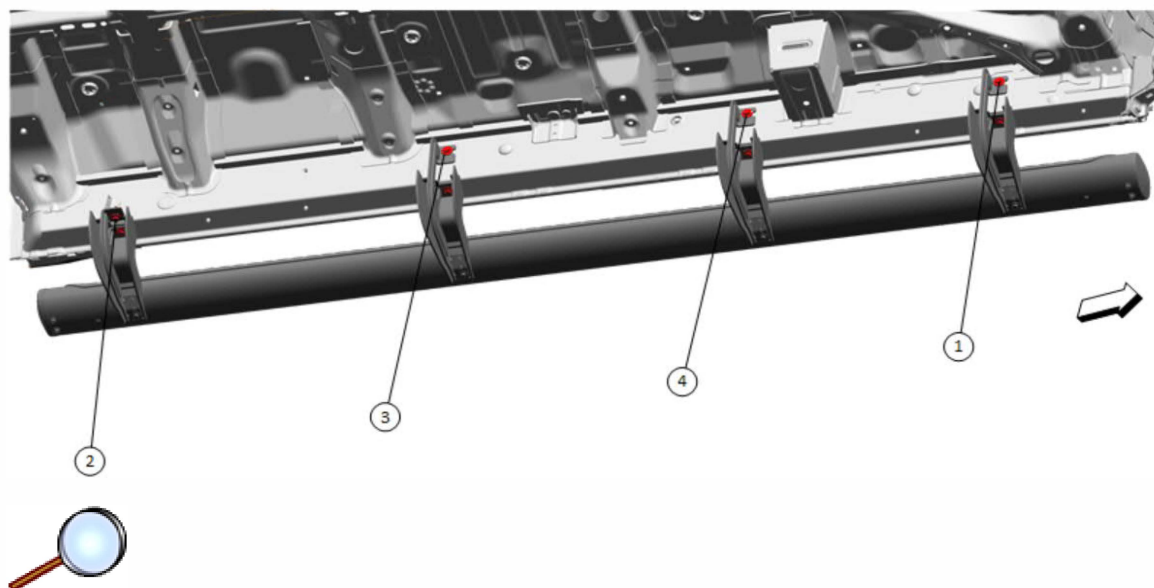

7. Tighten the top horizontal M8 bolts to **25 N.m (18 lb ft)** according to sequence shown.
8. **Verify torque on all hardware.**
9. Repeat steps 2 through 8 for right hand side assist step assembly.
10. Lower the vehicle.