

ACCESSORIES

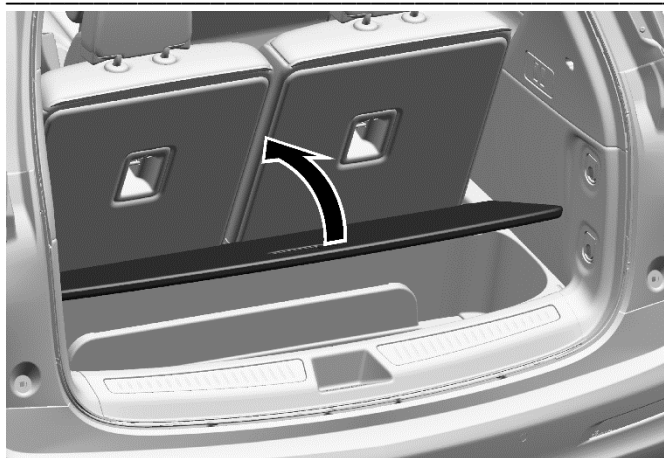

Step 1: Lift Lid in cargo area.

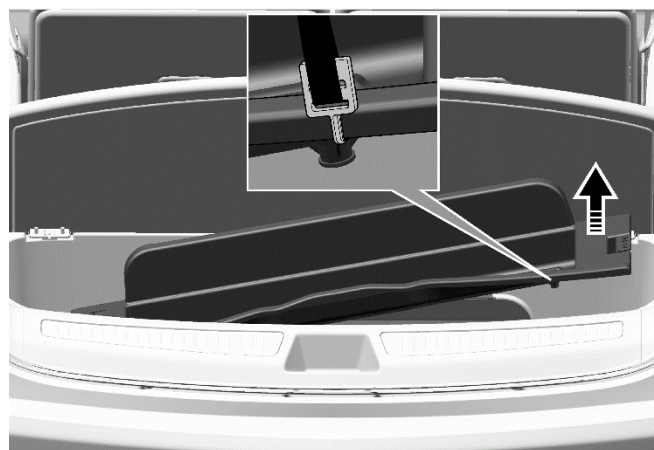

Step 2: Lift right side of bin and place hook under lip. Then re-install bin in design position.

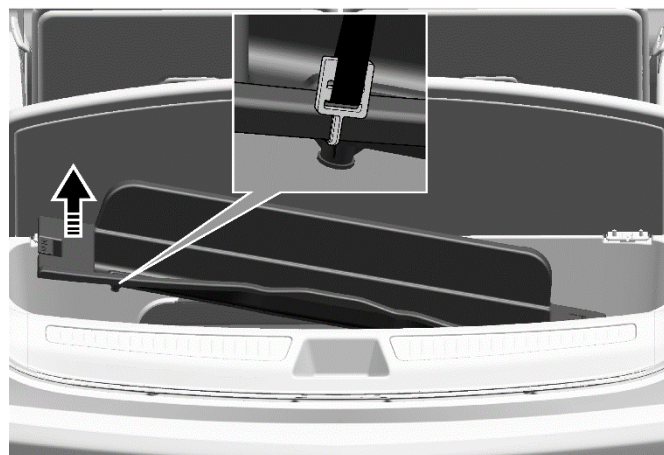

Step 3: Lift left side of bin and place hook under lip. Then re-install bin in design position.

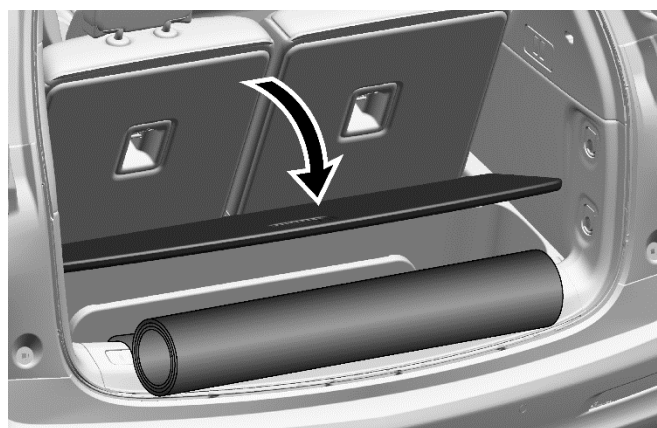

Step 4: Close Lid in cargo area.

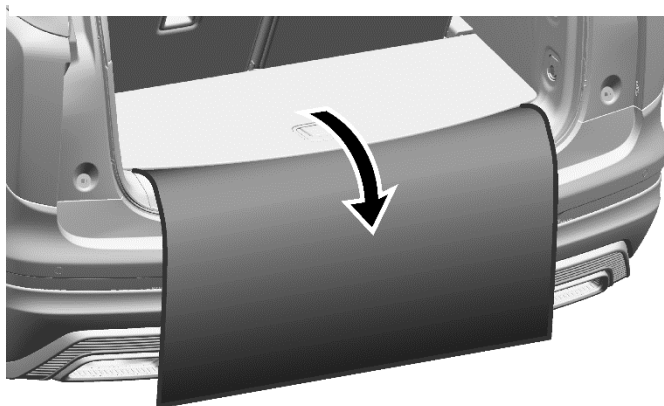

Step 5: To use, unroll protector over the bumper. Make sure the logo on the protector is facing up.

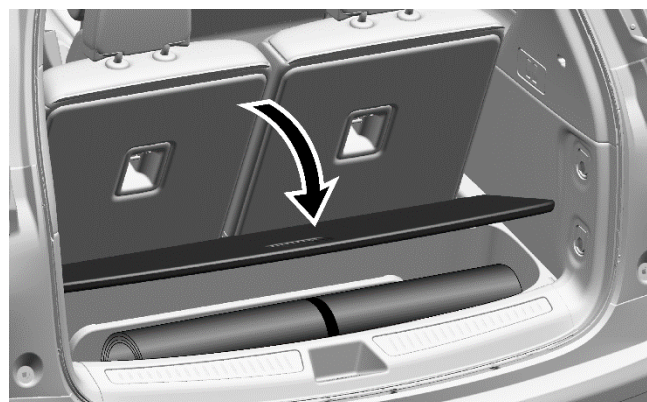

Step 6: To store, roll and secure protector with Velcro. Then stow protector under the cargo floor. Do not detach hooks.

Rear Bumper Cover Installation

IR 15FE19

PART No.

SHEET

1 of 3

ALL INFORMATION WITHIN ABOVE BORDER TO BE PRINTED EXACTLY AS SHOWN ON 8.5 x 11 WHITE 16 POUND NON-BOND RECYCLABLE PAPER. PRINT ON BOTH SIDES, EXCLUDING TEMPLATES. TO BE UNITIZED IN ACCORDANCE WITH GMCCA SPECIFICATIONS.

Date	Revision	Auth	DR
15FE19	Init Rel - Toni Gojcaj	NA	

**Title Installation Instructions
Rear Bumper Cover Installation**

PART No. 84393000

SHEET 1 of 3

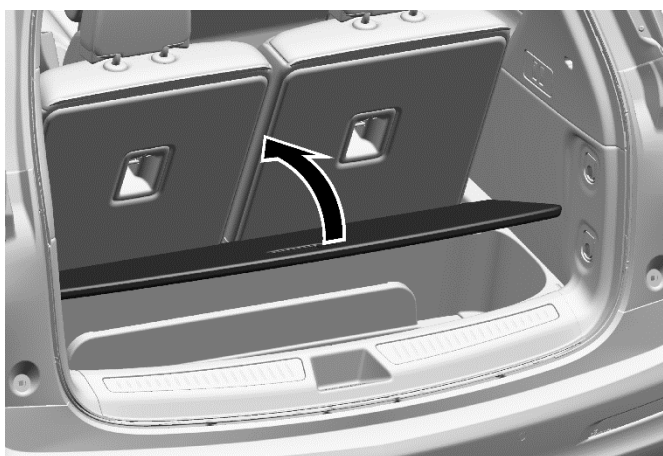

Étape 1 : Soulever le couvercle de l'espace de chargement.

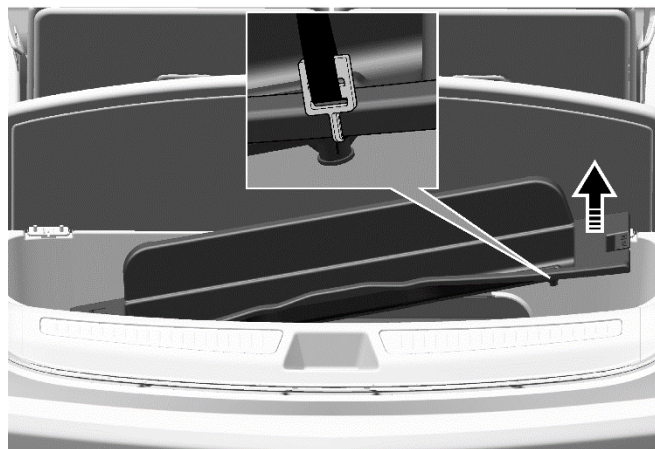

Étape 2 : Soulever le côté droit du bac et placer le crochet sous la lèvre. Remettre le bac dans sa position d'origine.

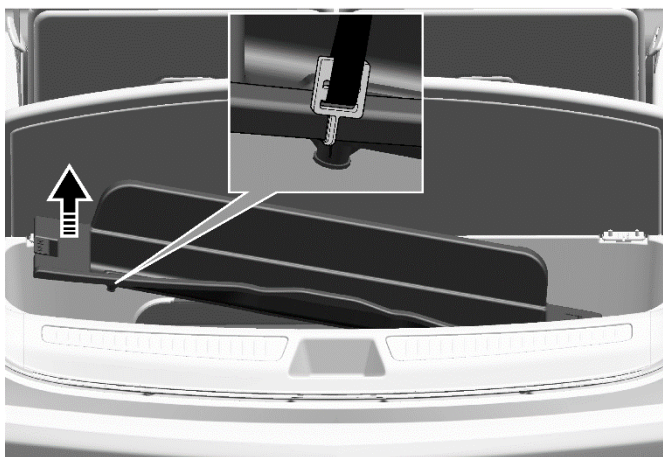

Étape 3 : Soulever le côté gauche du bac et placer le crochet sous la lèvre. Remettre le bac dans sa position d'origine.

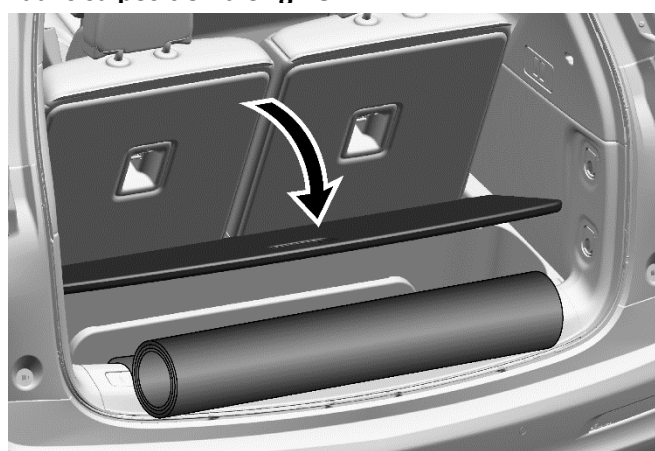

Étape 4 : Fermer le couvercle de l'espace de chargement.

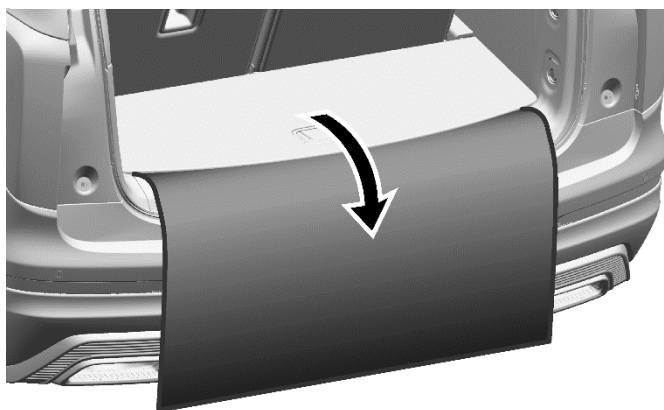

Étape 5 : Pour utiliser le protecteur, il suffit de le dérouler sur le parechoc. S'assurer que le logo du protecteur est orienté vers le haut.

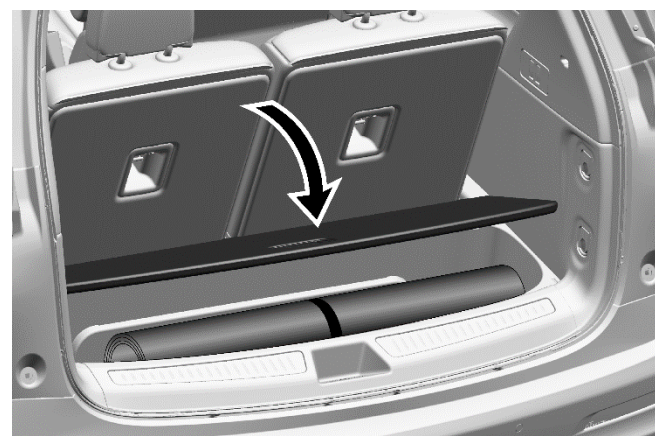

Étape 6 : Pour ranger le protecteur, il suffit de l'enrouler et de le fixer avec la bande velcro. Ranger ensuite le protecteur sous le plancher de chargement. Ne pas dégager les crochets.

Rear Bumper Cover Installation

IR 15FE19

PART No.

SHEET

2 of 3

ALL INFORMATION WITHIN ABOVE BORDER TO BE PRINTED EXACTLY AS SHOWN ON 8.5 x 11 WHITE 16 POUND NON-BOND RECYCLABLE PAPER. PRINT ON BOTH SIDES, EXCLUDING TEMPLATES. TO BE UNITIZED IN ACCORDANCE WITH GMCCA SPECIFICATIONS.

Date	Revision	Auth	DR
15FE19	Init Rel - Toni Gojcaj	NA	

**Title Installation Instructions
Rear Bumper Cover Installation**

PART No. 84393000

SHEET 2 of 3

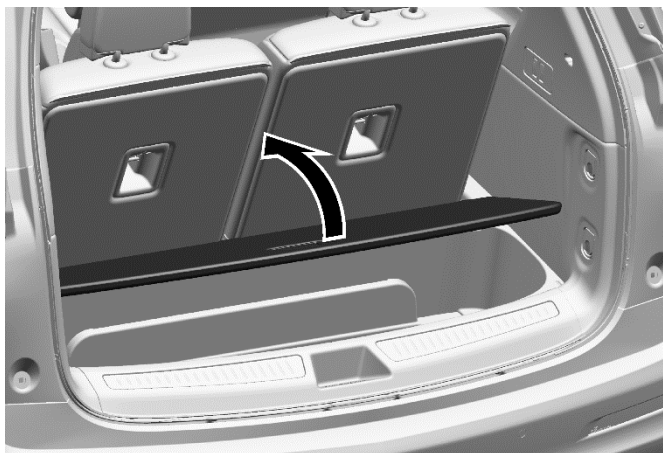

Paso 1: Levante la tapa en el área de carga.

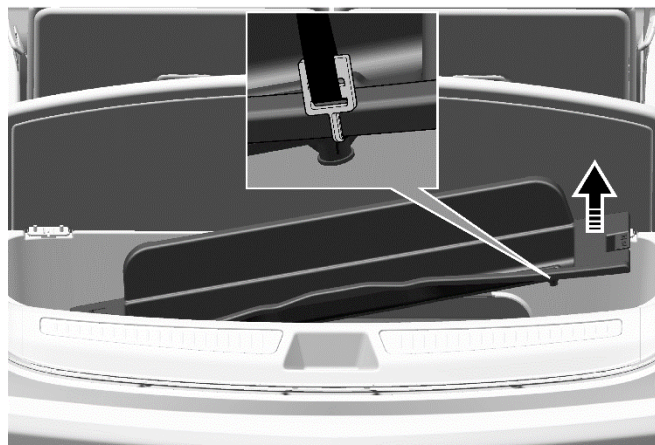

Paso 2: Levante el lado derecho del depósito y coloque el gancho debajo del labio. Después vuelva a instalar el depósito en la posición de diseño.

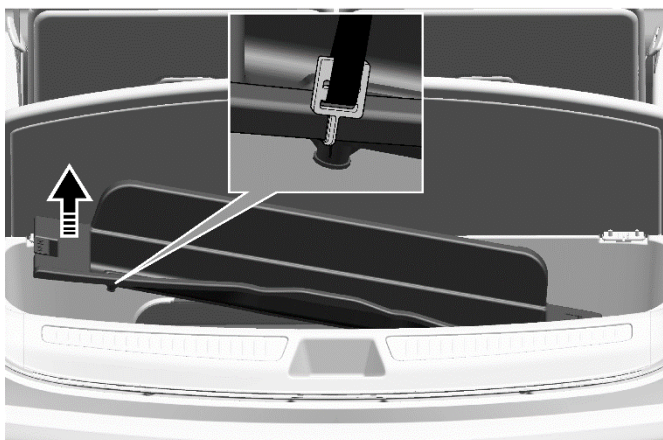

Paso 3: Levante el lado izquierdo del depósito y coloque el gancho debajo del labio. Después vuelva a instalar el depósito en la posición de diseño.

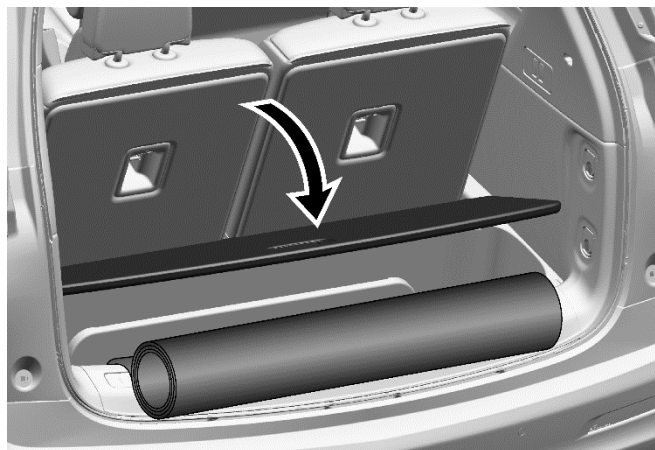

Paso 4: Cierre la tapa en el área de carga.

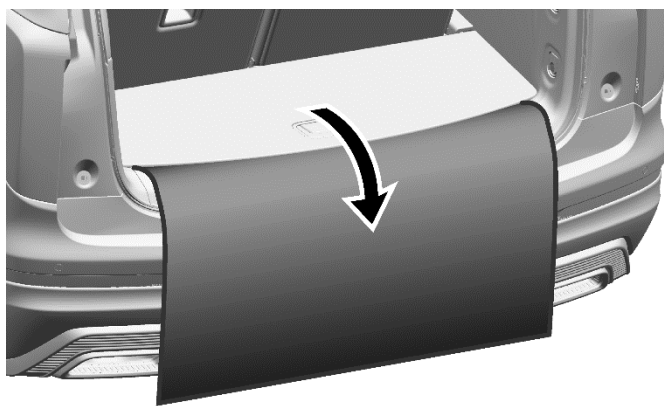

Paso 5: Para usar, desenrolle el protector sobre la defensa. Asegúrese que el logotipo en el protector vea hacia arriba.

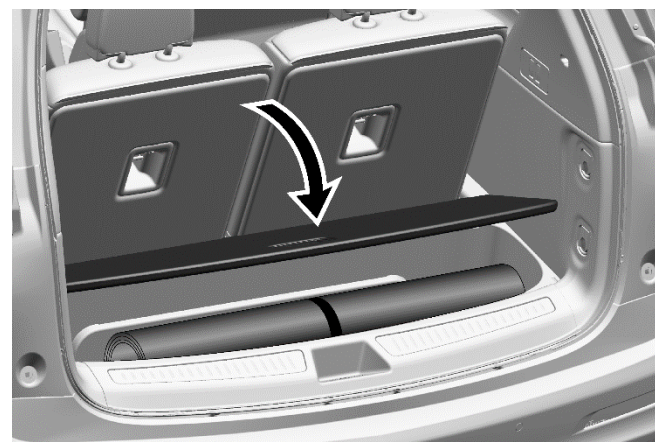

Paso 6: Para almacenar, enrolle y asegure el protector con Velcro. Después almacene el protector debajo del piso de carga. No desconecte los ganchos.

Rear Bumper Cover Installation

IR 15FE19

PART No.

SHEET

3 of 3

ALL INFORMATION WITHIN ABOVE BORDER TO BE PRINTED EXACTLY AS SHOWN ON 8.5 x 11 WHITE 16 POUND NON-BOND RECYCLABLE PAPER. PRINT ON BOTH SIDES, EXCLUDING TEMPLATES. TO BE UNITIZED IN ACCORDANCE WITH GMCCA SPECIFICATIONS.

Date	Revision	Auth	DR
15FE19	Init Rel - Toni Gojcay	NA	

Title Installation Instructions
Rear Bumper Cover Installation

PART No. 84393000

SHEET 3 of 3