

# Rear Mud Guard Package Installation

## Installation Instructions Part Number

84433579

**Note:** Please read instructions thoroughly before starting.

### Rear Mud Flap Guard Kit Contents

Qty	Description
1	Left Hand Splash Guard
1	Right Hand Splash Guard
4	M4.2 x 25 Screw with Washer
2	M4.2 U-Nut
1	Instruction Sheet

### Tools Required

- T15 Torx Bit
- Drill with 13/64" (5.0mm) Drill Bit
- Awl
- Clean Cloth/Rag
- Isopropyl Alcohol

### Installation Procedure

**Note:** Do not use power tools to install splash guard fasteners.

1. Remove rear wheel and tire assembly. Refer to [Tire and Wheel Removal and Installation](#) in Vehicle Service Manual.
2. Clean and degrease body panel where splash guards will be located.
3. Using isopropyl alcohol, clean area where tape will contact body panel.

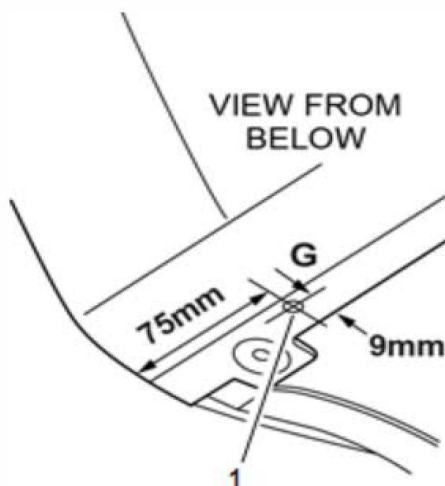

**Caution:** Always check scale, size and position of all templates before drilling. Failing to do so may cause damage to the vehicle, misalignment of components or the inability to install the accessory.

4. Measure, mark and drill a 13/64" (5.0 mm) hole (1) at location (A).

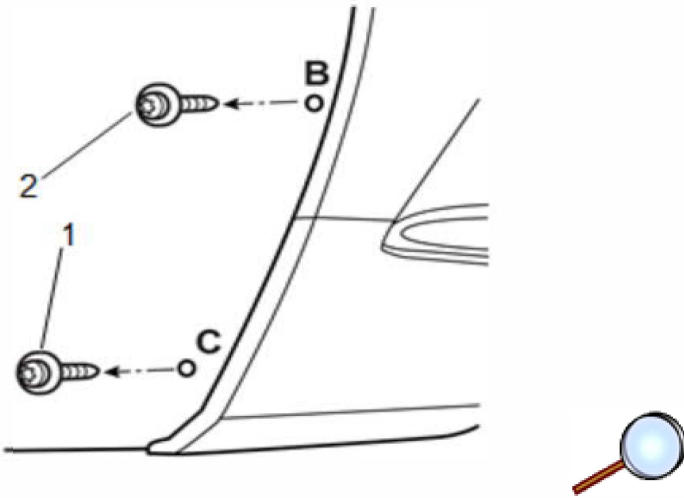

5. Remove existing screws (1), (2) at locations (B) and (C). Retain lower screw (1) for later use.

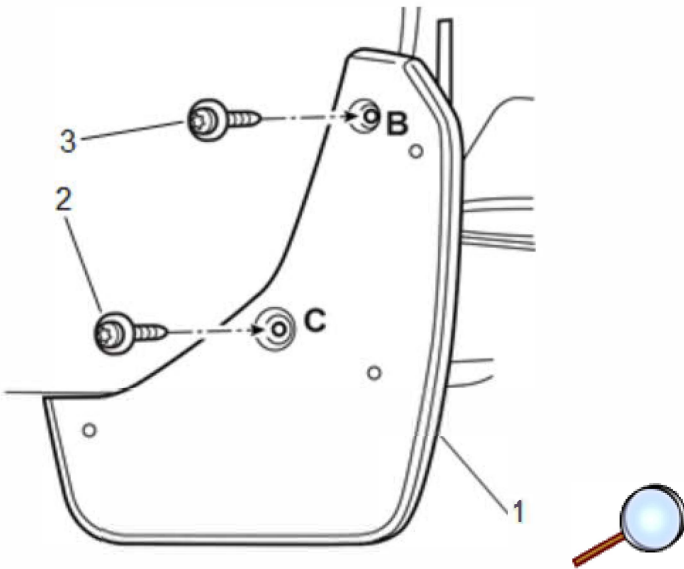

**Caution:** Use the correct fastener in the correct location. Replacement fasteners must be the correct part number for that application. Fasteners requiring replacement or fasteners requiring the use of thread locking compound or sealant are identified in the service procedure. Do not use paints, lubricants, or corrosion inhibitors on fasteners or fastener joint surfaces unless specified. These coatings affect fastener torque and joint clamping force and may damage the fastener. Use the correct tightening sequence and specifications when installing fasteners in order to avoid damage to parts and systems.

6. Making sure that the tape pull tab is visible, place splash guard (1) to the vehicle taking care to remove any gaps to the vehicle.
7. Install supplied screw with washer (3) at location (B). Use an awl if necessary to align the hole on the splash guard to the vehicle hole.
8. Install retained screw (2) from step 5 at location (C). Use an awl if necessary to align the hole on the splash guard to the vehicle hole.

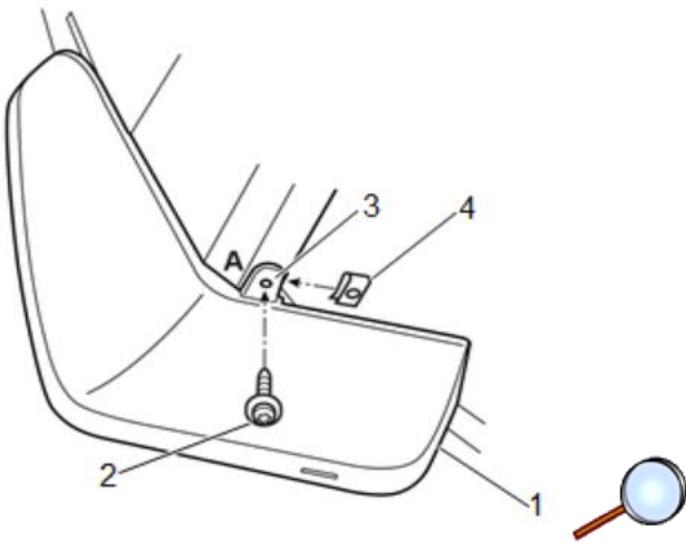

9. Pull splash guard (1) rearward and inboard to align splash guard tab hole (3) with newly drilled hole (A) in fascia and install supplied M4.2 x 25 screw (2) and u-nut (4) at location (A). U-nut should be used as a nut above the fascia.

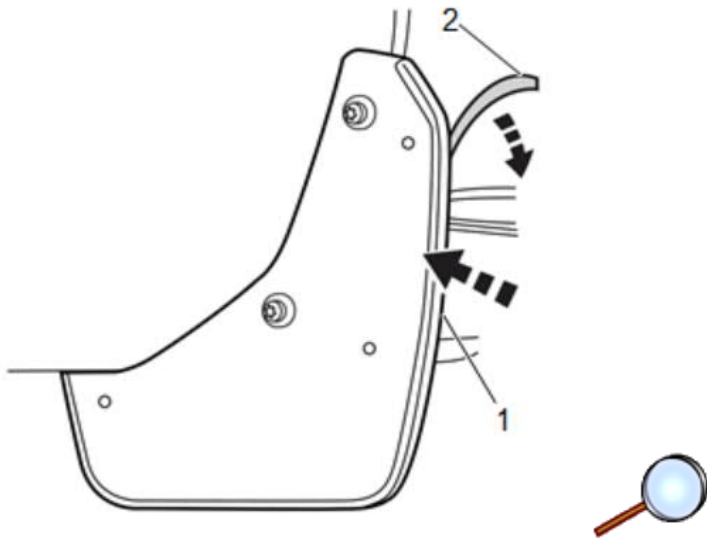

10. Remove tape pull tab (2) and apply firm pressure to the splash guard (1) along the tape line to adhere the tape to the fender. Hold the firm pressure for a minimum of 60 seconds to properly adhere the tape.
11. Install rear wheel and tire assembly. Refer to [Tire and Wheel Removal and Installation](#) in Vehicle Service Manual.
12. Repeat for other side.
13. Guards can be cleaned with any commercially available cleaner.

**Note:** Maximum torque on M4.2 screw is 3.0 N•m.