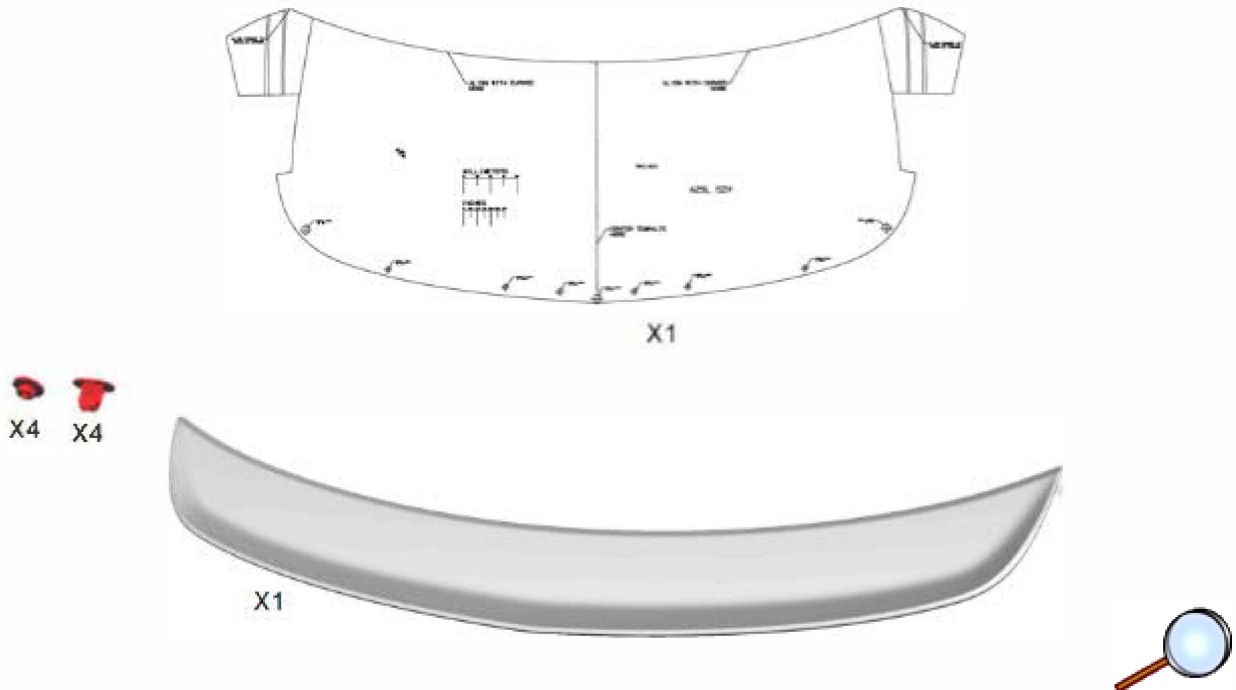

Document ID: 5756759

Rear End Spoiler Package Installation

Installation Instructions Part Number

84503539

[Kit Contents](#)

Tools Required

- Power Drill
- 4 mm Drill Bit
- 8.5 mm Drill Bit
- 15 mm Drill Bit
- Deburring Tool
- Measuring Tape
- Masking Tape
- Scissors
- Torque Wrench
- Ratchet
- 10 mm Socket

© 2021 General Motors. All rights reserved.

Center Punch

Hair Dryer (If vehicle has production spoiler installed)

50 lb. Monofilament line (fishing line) (If vehicle has production spoiler installed)

Rubber Roller

Solvent Pack

Procedure

Preliminary Steps

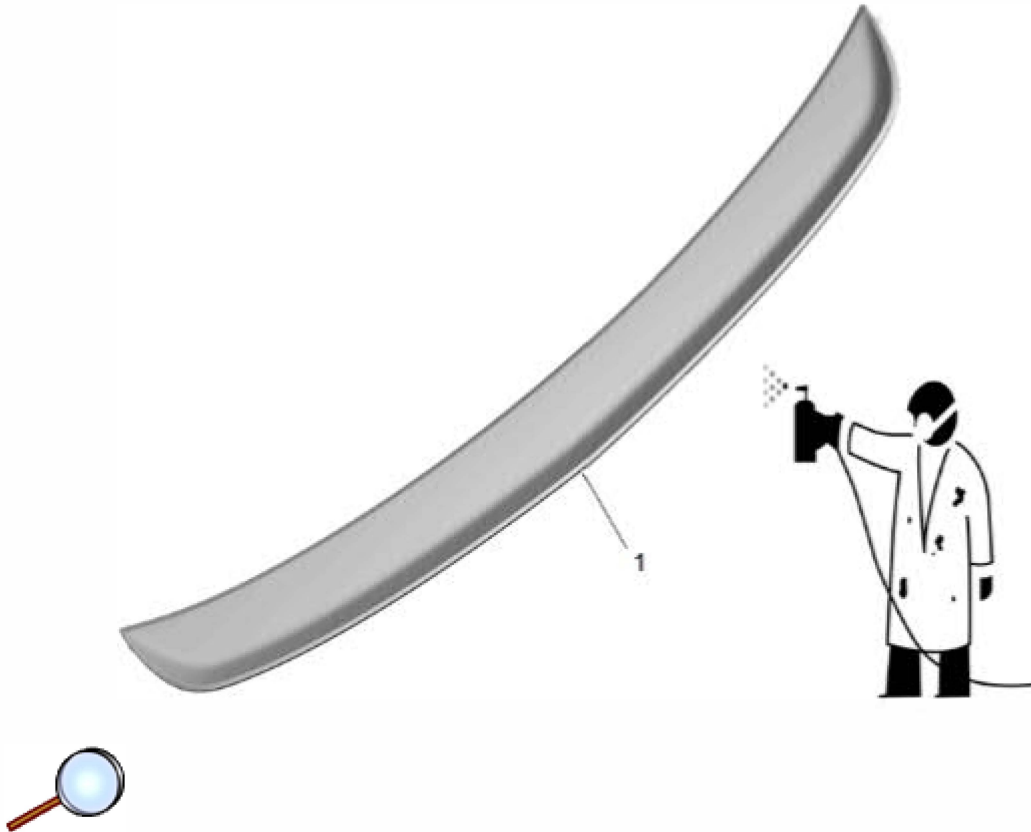

1. Refinish spoiler (1) as necessary. Refer to refinish procedures in Vehicle Service Manual.
2. Using soap and water, wash the rear compartment lid area where spoiler is to be installed.



3. Use a small flat-bladed tool to pull and release the rear compartment lid latch cover (1) .
4. Rear Compartment Lid Latch Cover (1) » Remove

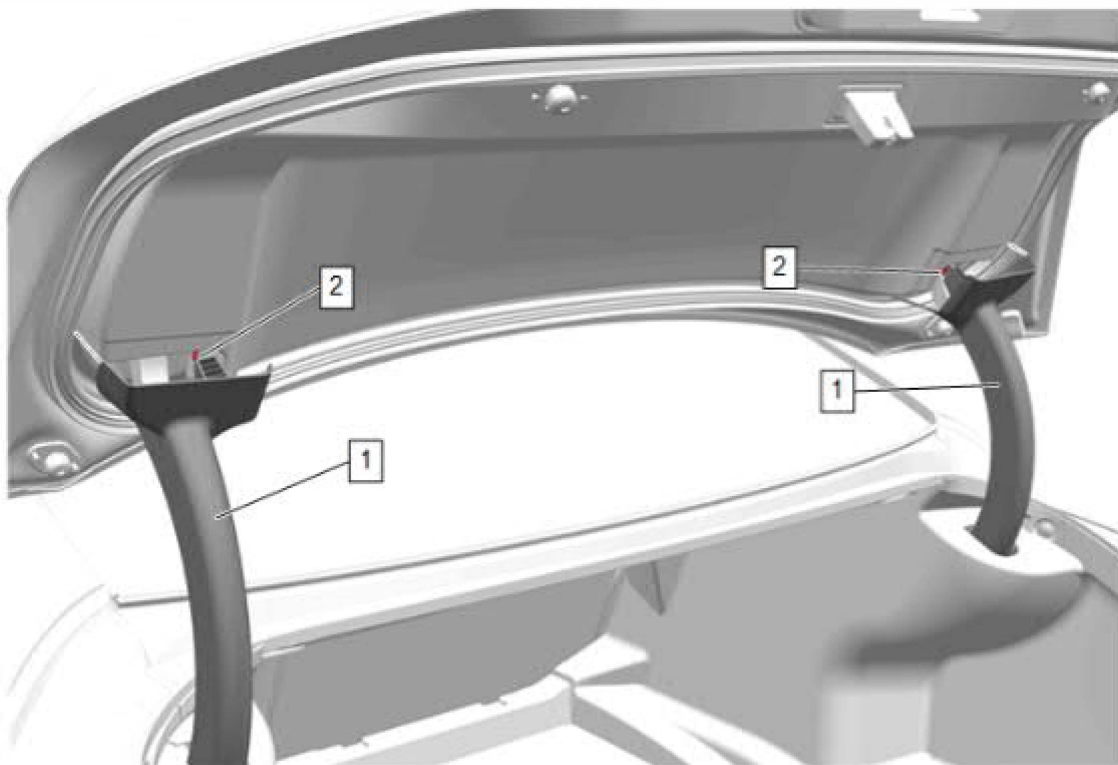

5. Use a small flat-bladed tool at the top of the rear compartment lid hinge cover(1) to release the hinge cover retainer(2) on both sides of the vehicle.

Note: The rear compartment lid hinge cover does not need to be removed from the vehicle.

6. Rear Compartment Lid Hinge Cover (1) » Reposition [2x]

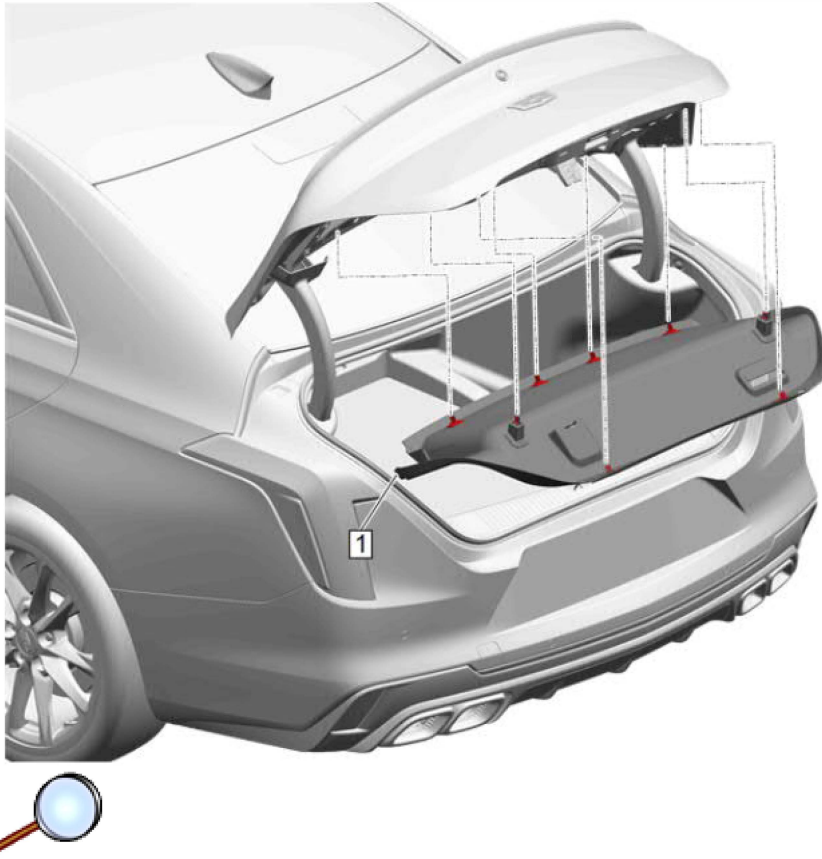

7. Use a flat-bladed plastic tool to disengage the push-in retainers from the sheet metal.
8. Rear Compartment Lid Inner Panel Trim (1) » Remove
9. Temporarily clip hinge covers back in until rear compartment lid inner trim is ready to go back to post-installation.

Remove Production Spoiler, If Equipped

Bolt on Spoiler Removal

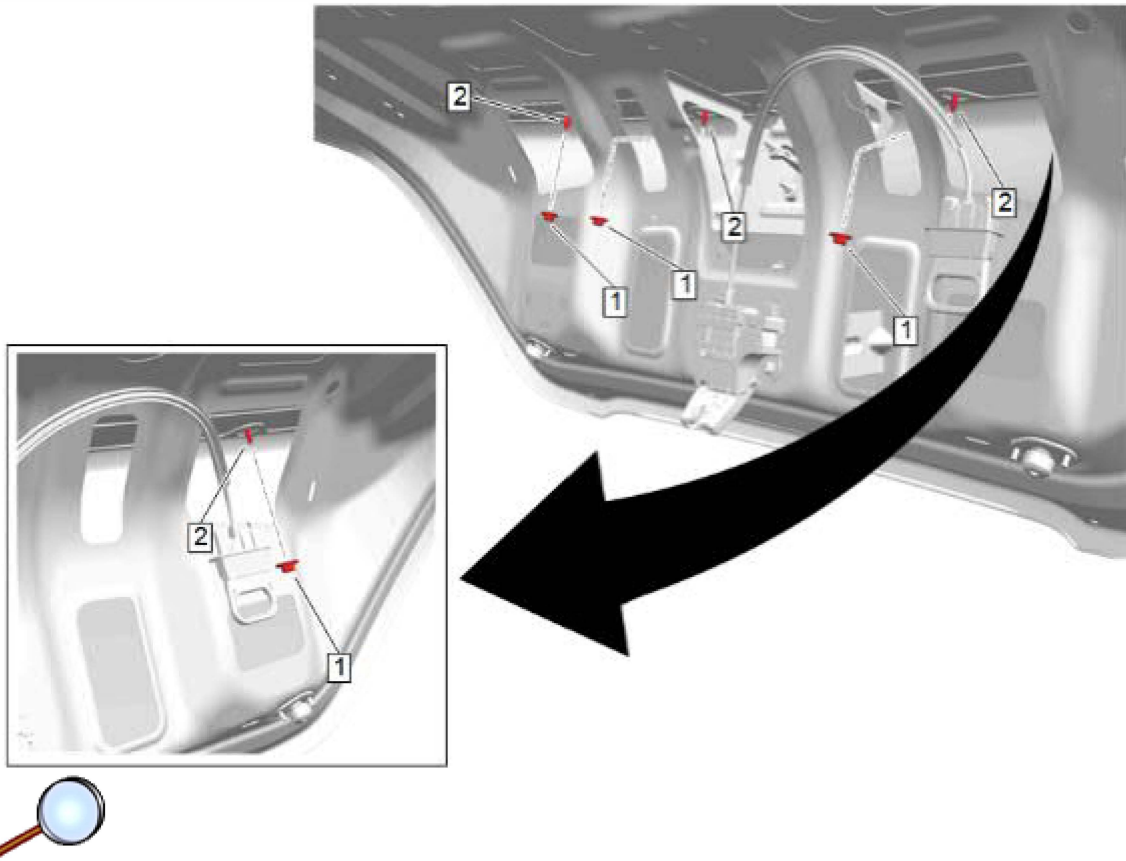

Note: If vehicle is not equipped with production spoiler, continue to Drilling Instructions section.

Note: If spoiler is attached with nuts, then proceed with step 1. If not, then proceed to Stick on Spoiler Removal.

1. Using a 10 mm socket, remove the attachment nuts (1) from spoiler studs (2) from inside rear compartment lid.

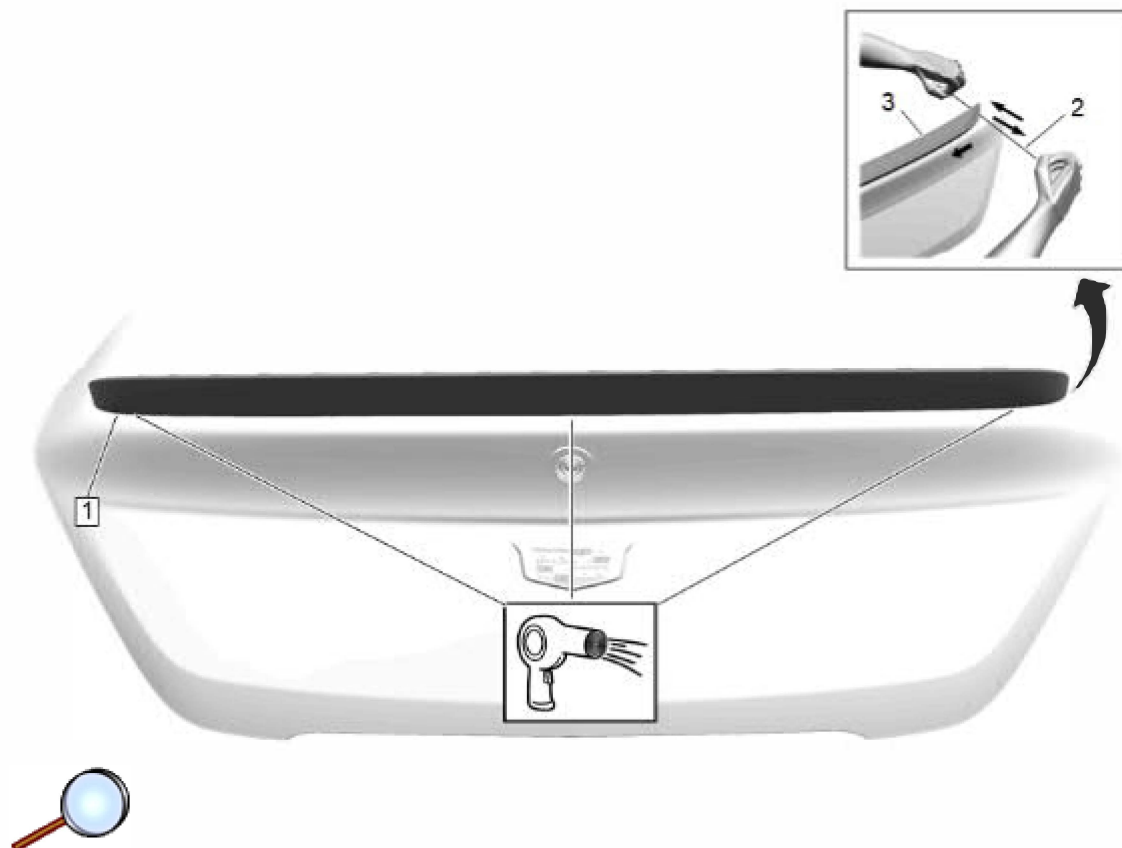

Caution: Applying excessive heat to the rear fascia/spoiler may damage the paint and surrounding panel surfaces during removal. Heat temperature SHOULD NOT exceed 79°C (175°F).

Warning: DO NOT USE A HEAT GUN. (Heat gun temperatures will soften material and damage paint).

2. Heat adhesive at base of spoiler mounting (1) with low heat (Personal Hair dryer) until adhesive can be sliced easily with a piece of monofilament line (fishing line) .
3. Cut through tape with the monofilament line (2) at the corners until you hit the locating feature. Gently, lift up on the spoiler (3) applying slow upward pressure in order remove spoiler. (If spoiler does not easily detach, place monofilament line on other side of locating feature and cut through the additional tape.)

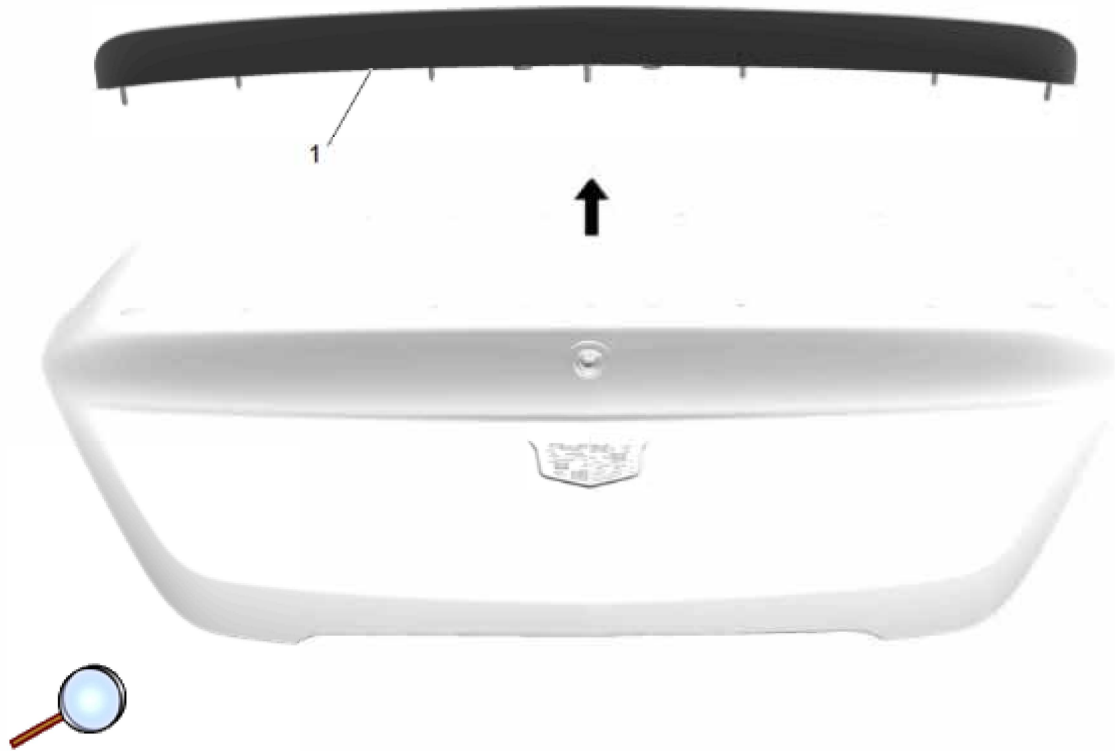

4. Lift and remove the spoiler (1) from the rear compartment lid.
5. Clean the tape and adhesive from the previous spoiler mounting area. Once complete proceed to **Spoiler Installation** section.

Stick on Spoiler Removal

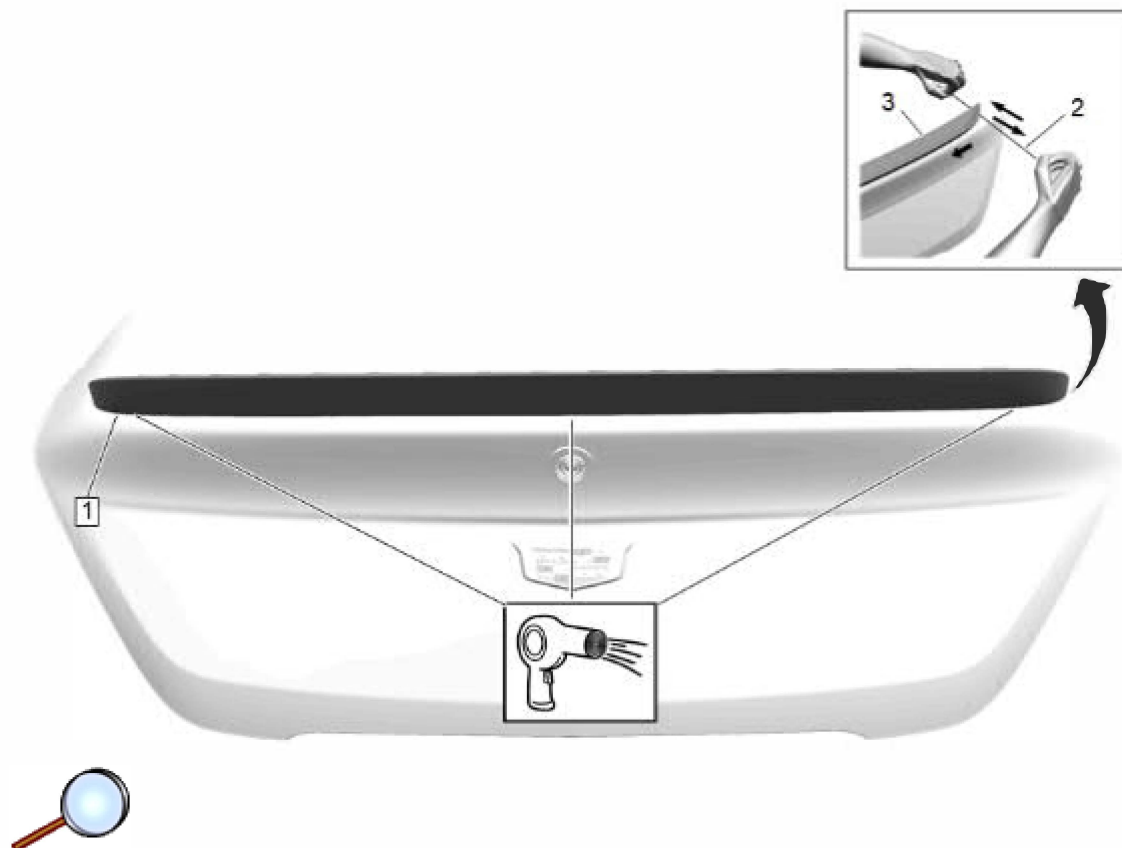

Caution: Applying excessive heat to the rear fascia/spoiler may damage the paint and surrounding panel surfaces during removal. Heat temperature SHOULD NOT exceed 79°C (175°F).

Warning: DO NOT USE A HEAT GUN. (Heat gun temperatures will soften material and damage paint).

1. Heat adhesive at base of spoiler mounting (1) with low heat (Personal Hair dryer) until adhesive can be sliced easily with a piece of monofilament line (fishing line) .
2. Cut through tape with the monofilament line (2) at the corners until you hit the locating feature. Gently, lift up on the spoiler (3) applying slow upward pressure in order remove spoiler. (If spoiler does not easily detach, place monofilament line on other side of locating feature and cut through the additional tape.)

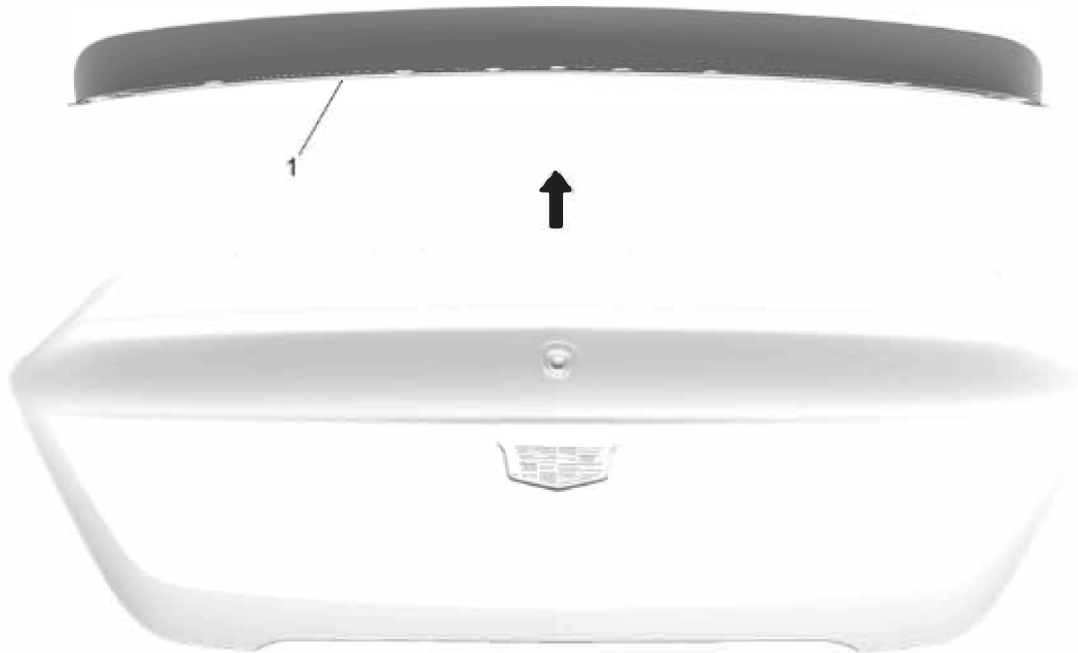

3. Remove the spoiler (1) from the rear compartment lid.
4. Clean the tape and adhesive from the previous spoiler mounting area. Once complete proceed to **Spoiler Installation** section.

Drilling Instructions

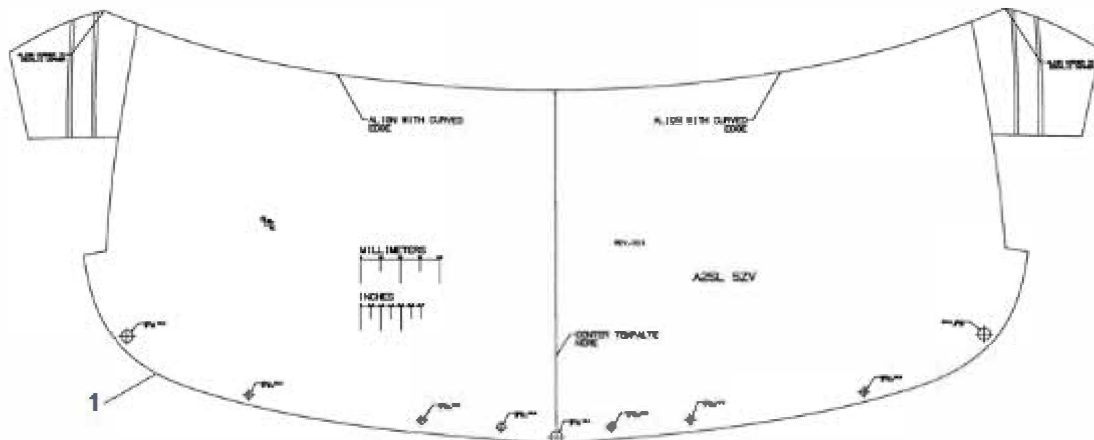

Note: If holes already exist on rear compartment lid, only drill new holes. No need to alter existing holes.

Note: If drilling is not required, due to production installed spoiler, skip this section and continue with Spoiler Installation section.

1. Locate the provided drilling template (1).

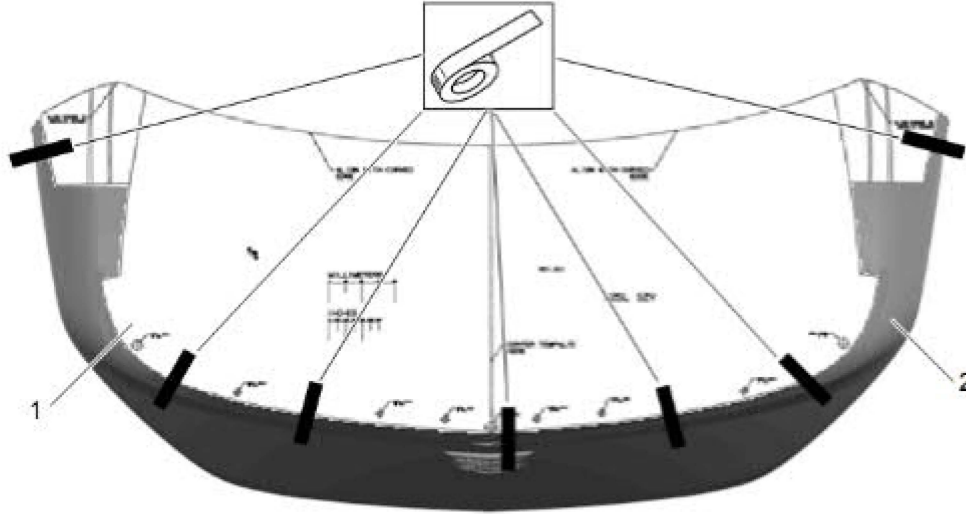

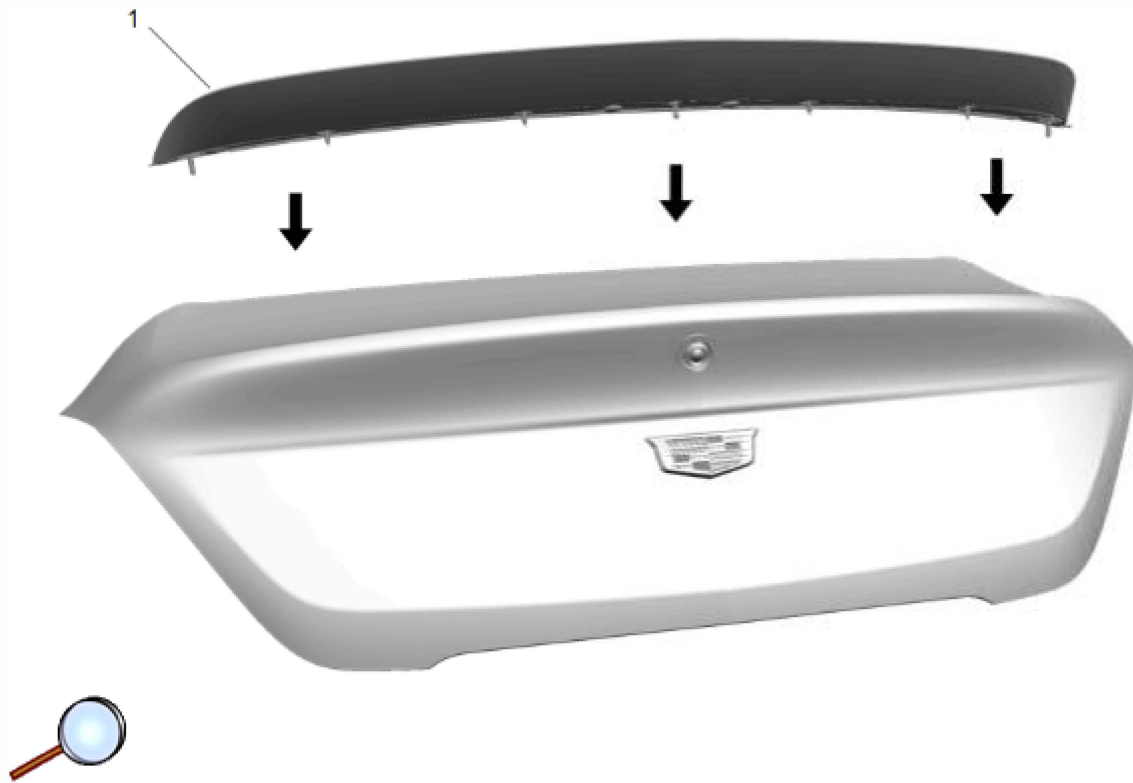

Caution: Always check scale, size and position of all templates before drilling. Failing to do so may cause damage to the vehicle, misalignment of components or the inability to install the accessory.

2. Position template (1) on rear compartment lid (2). Follow the directions on the template for layout procedure.
3. Tape template to rear compartment lid in several locations to secure template. Ensure that the holes and locating features identified still line up.

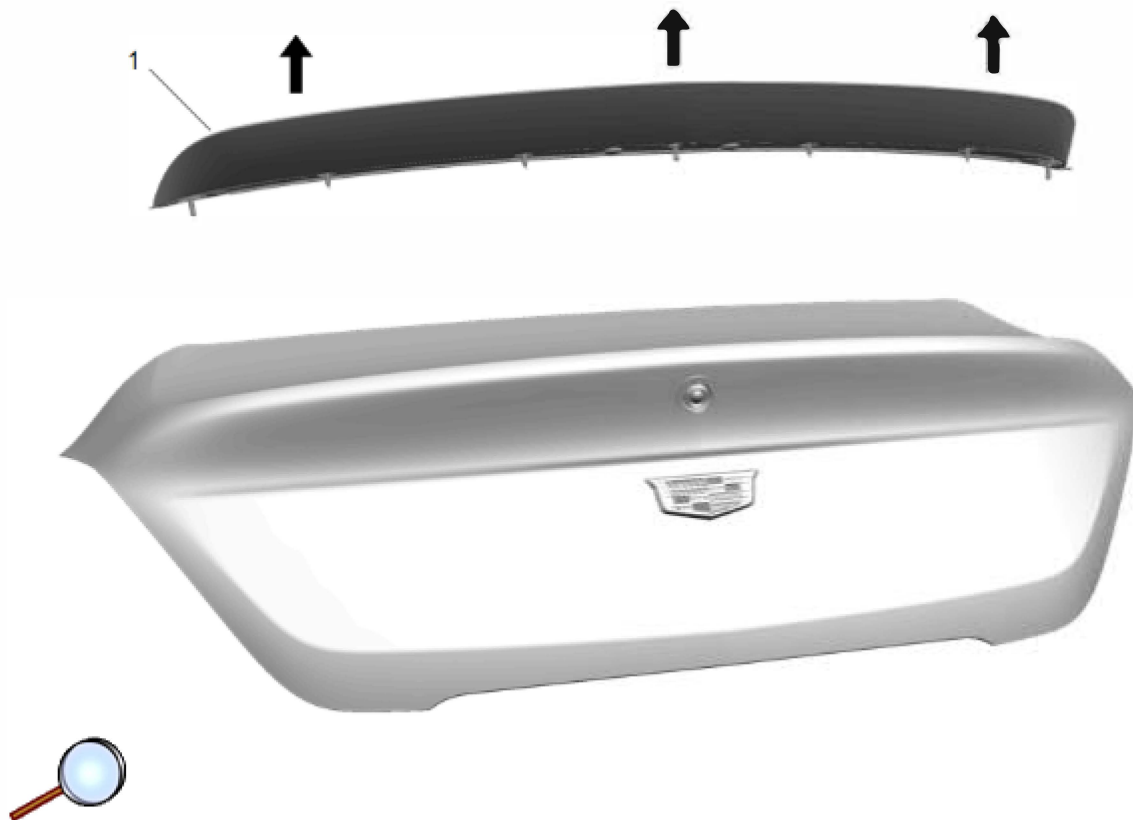

 4. Position spoiler (1) to rear compartment lid and verify layout.



 5. Once spoiler layout is verified, remove spoiler (1) and set aside.
© 2021 General Motors. All rights reserved.

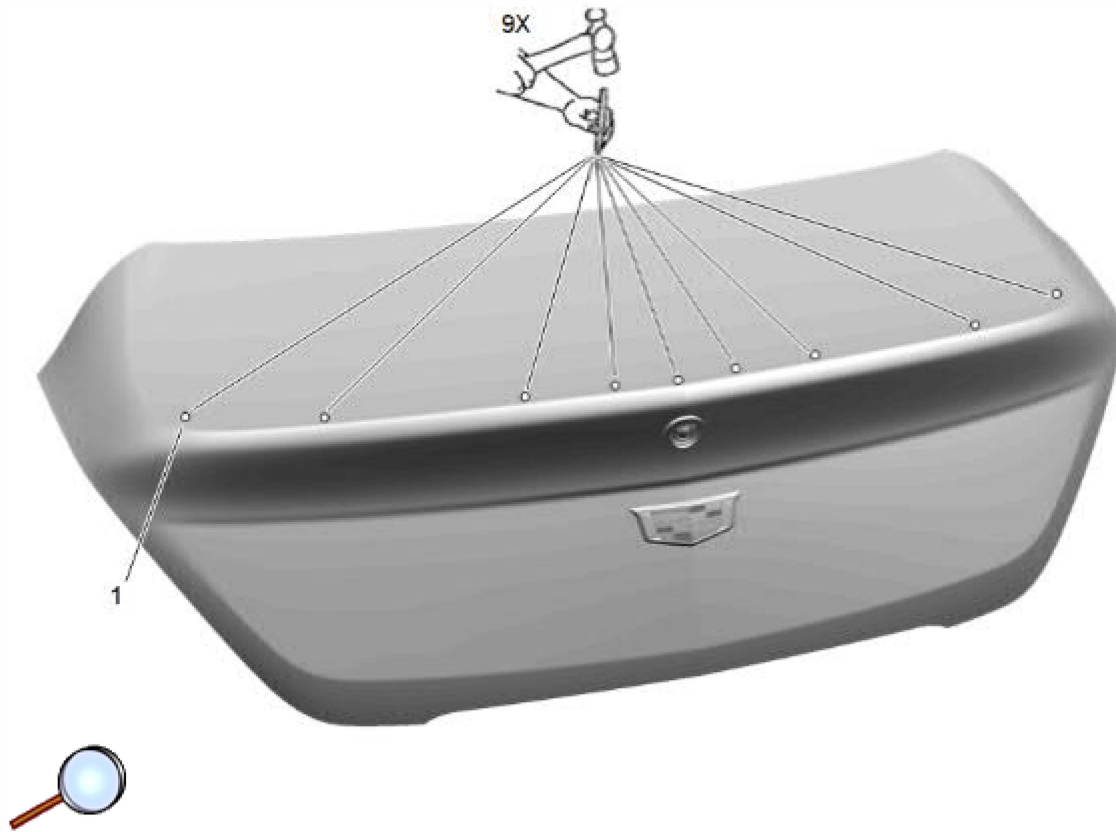

Note: If holes are already in rear compartment lid, do not punch new holes. (Only punch outside holes).

6. Punch the center of all 9 holes (1) as indicated on template.

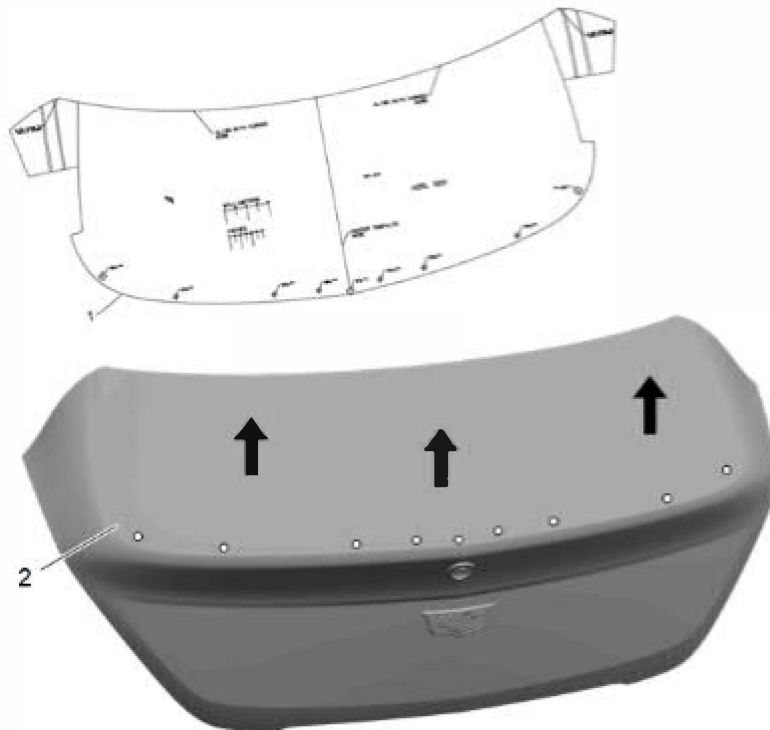

7. Remove template (1) from rear compartment lid (2).

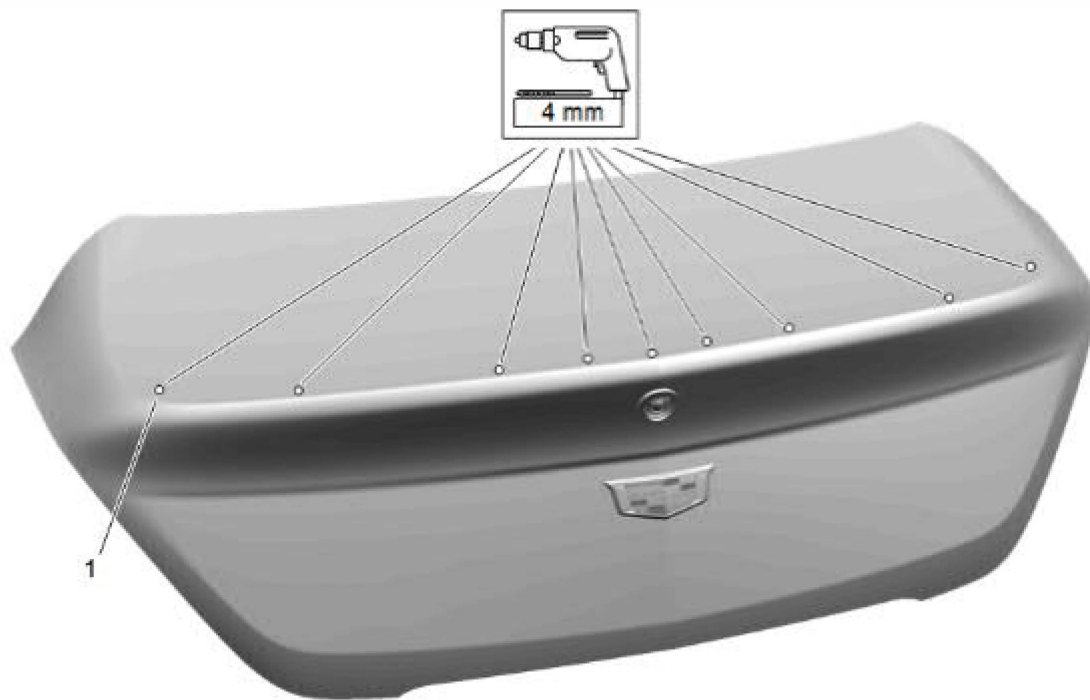

Note: If holes already exist, do not drill into existing holes. (Drill outside holes only).
8. Drill a 4mm (1/8") pilot hole (1) for all hole locations.

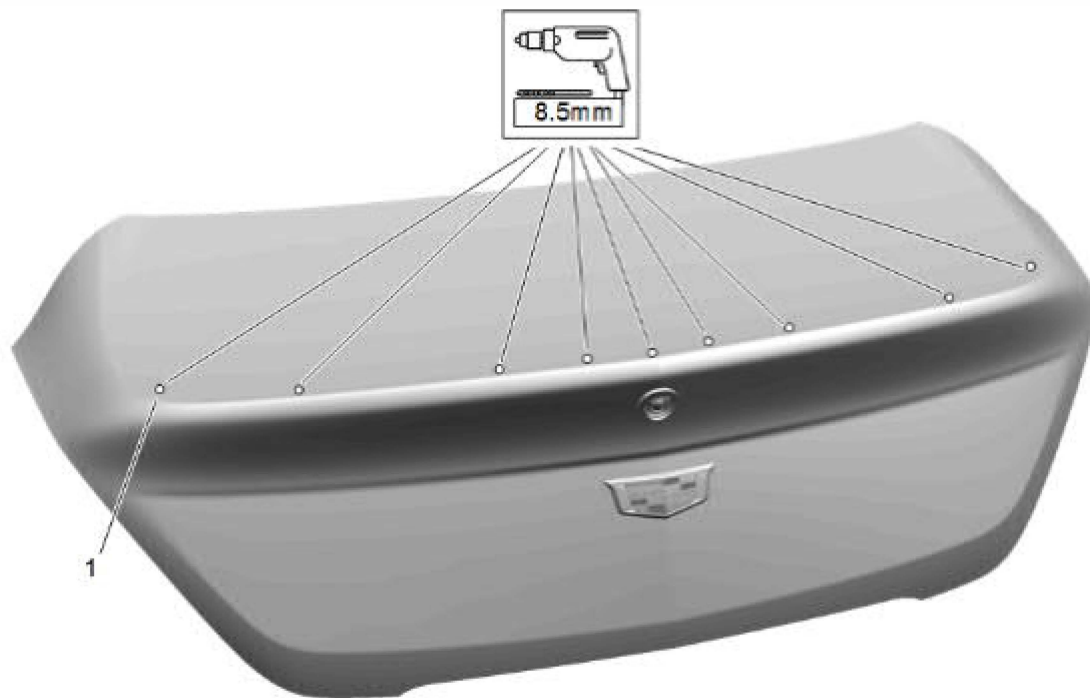

Note: If holes already exist, do not drill into existing holes. (Drill outside holes only).
9. Using a 8.5mm drill bit, drill through the holes (1) according to locations specified.

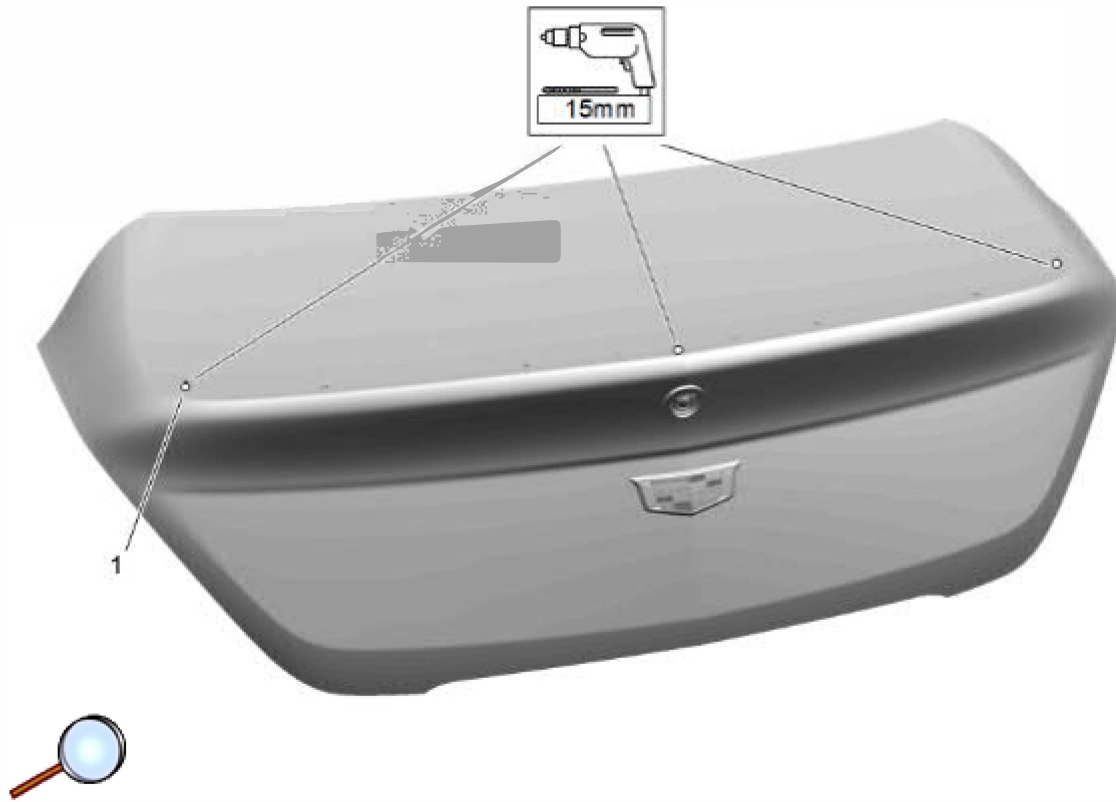

- Note:** If holes already exist, do not drill into existing holes.
10. Using a 15mm (5/8) drill bit, drill through the holes (1) according to locations specified.

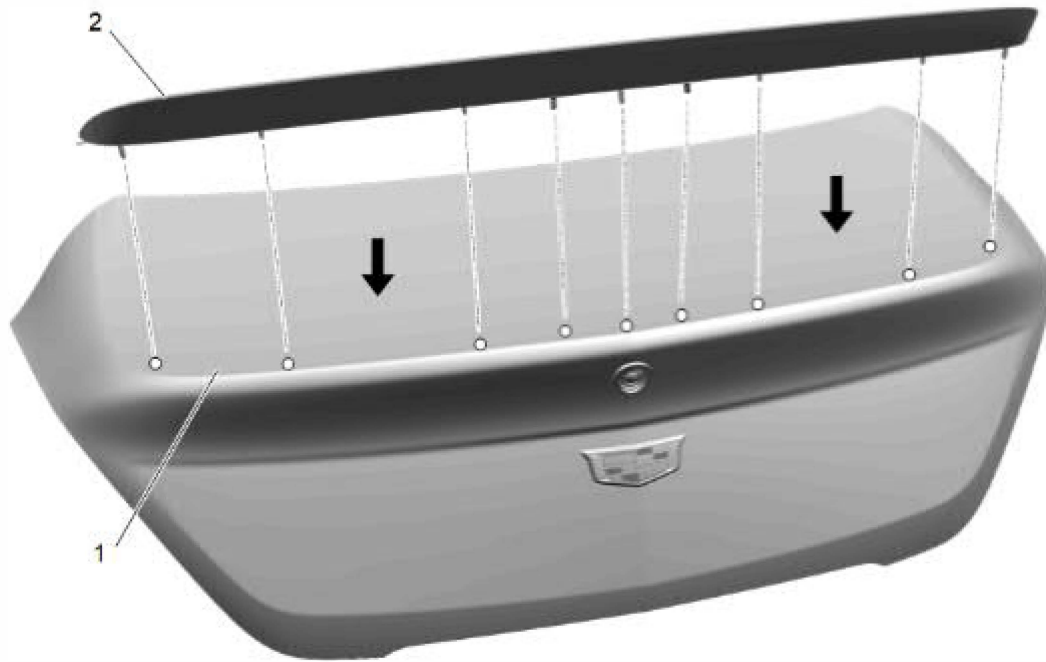

11. Verify spoiler (2) fits rear compartment lid (1).

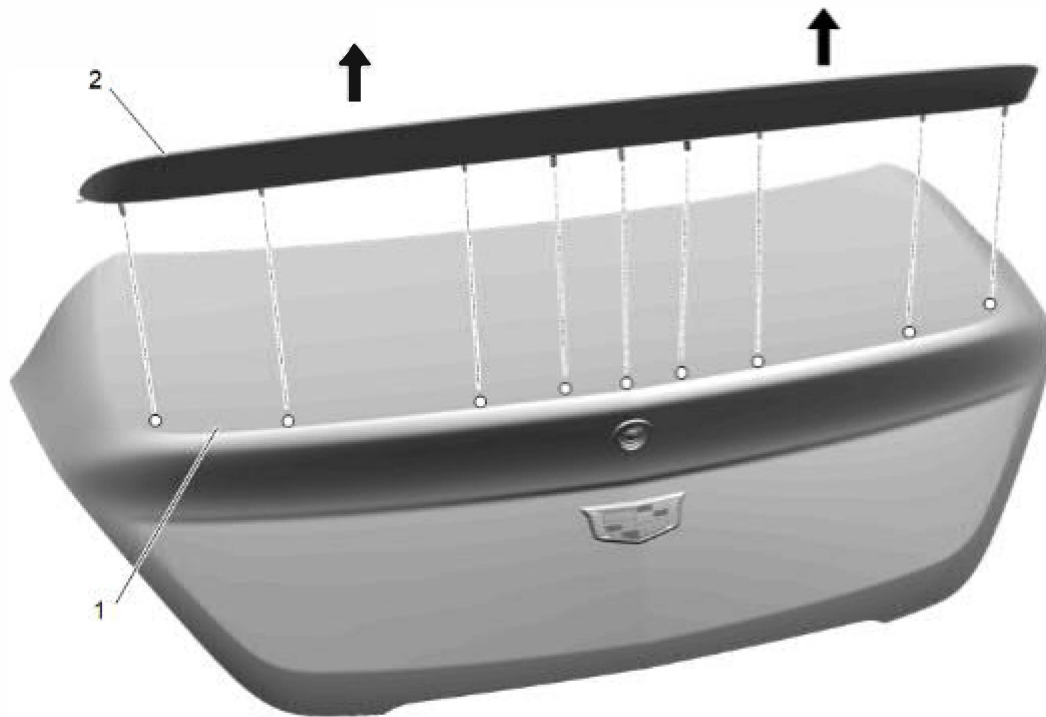

12. Once spoiler fitment is confirmed, remove spoiler (2) from rear compartment lid (1) and set aside.

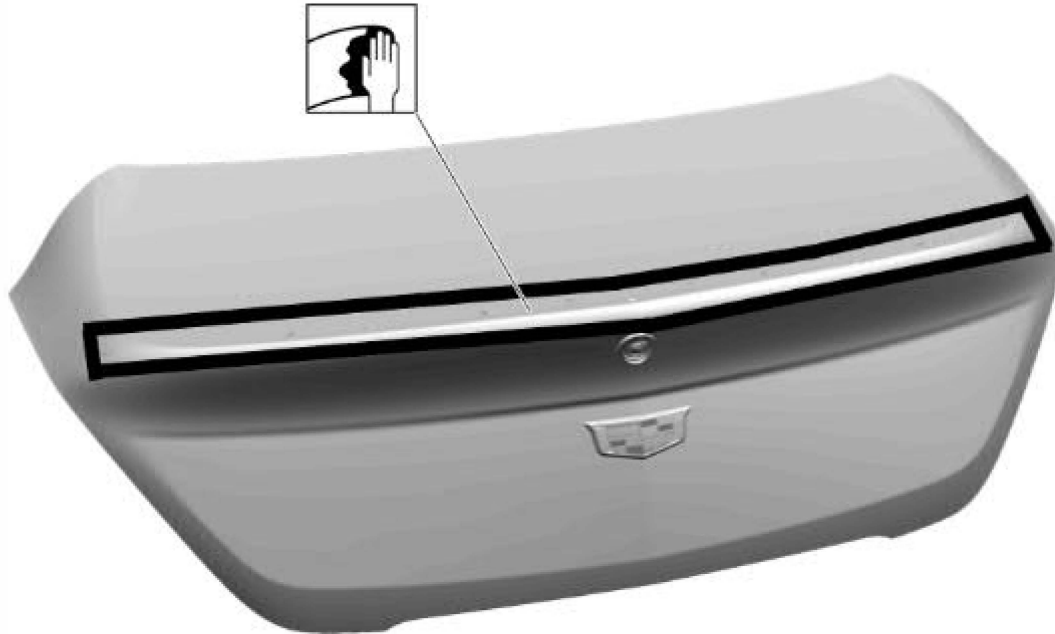

13. Clean rear compartment lid area with solvent pack.

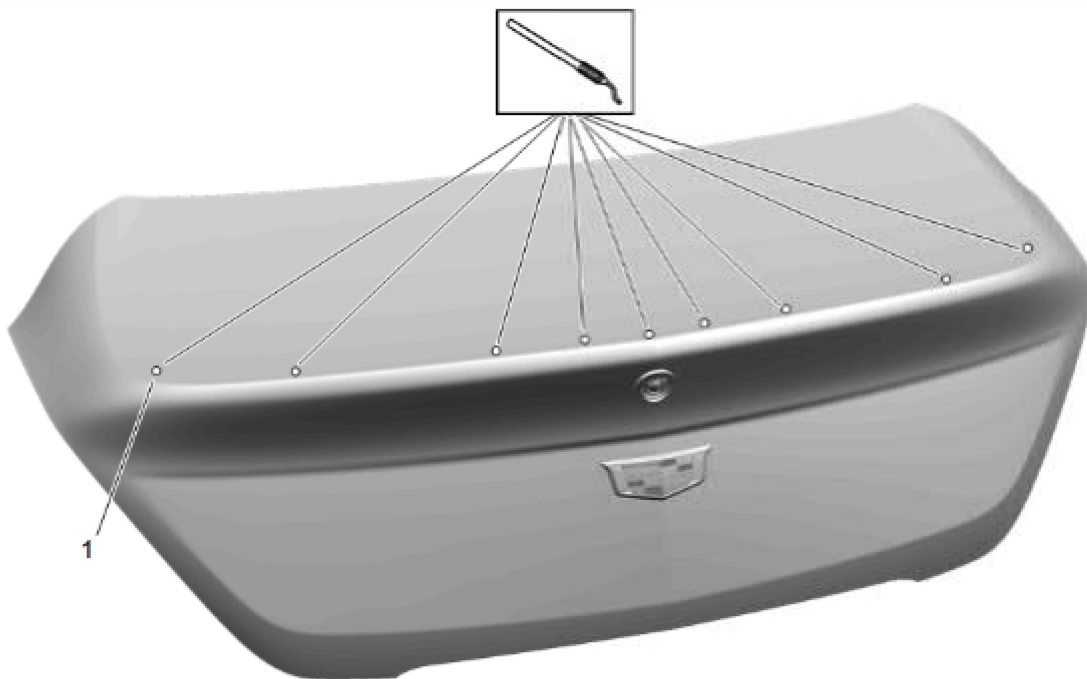

Note: Bare metal must be covered with corrosion protectant.
14. De-burr drilled holes (1) and apply corrosion protection P/N 12371287 or equivalent to all holes.

Spoiler Install

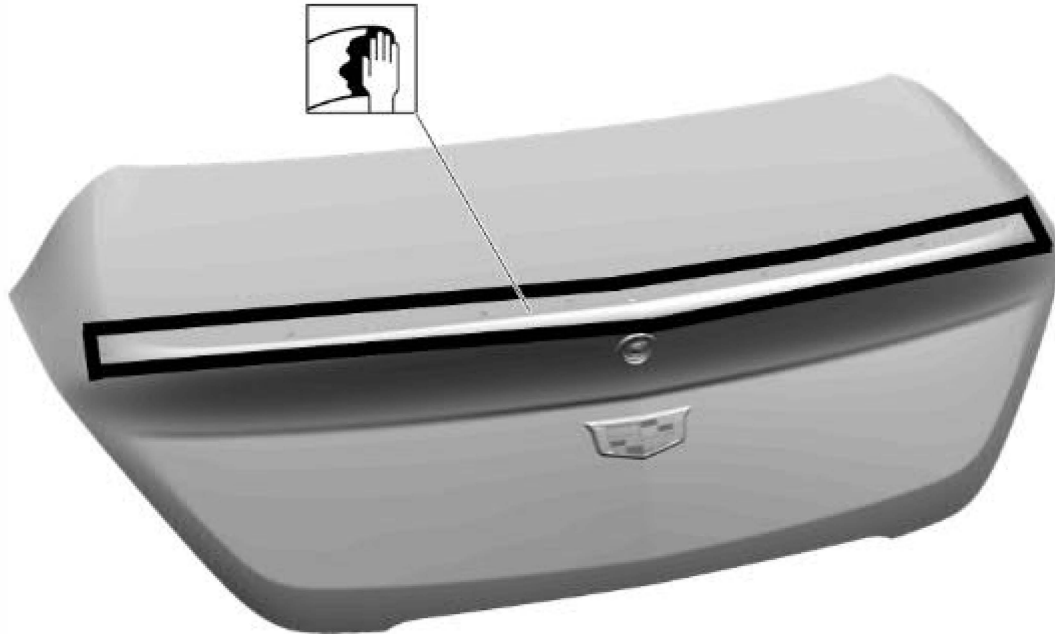

1. If the drilling section was skipped, then clean rear compartment lid area with solvent pack.

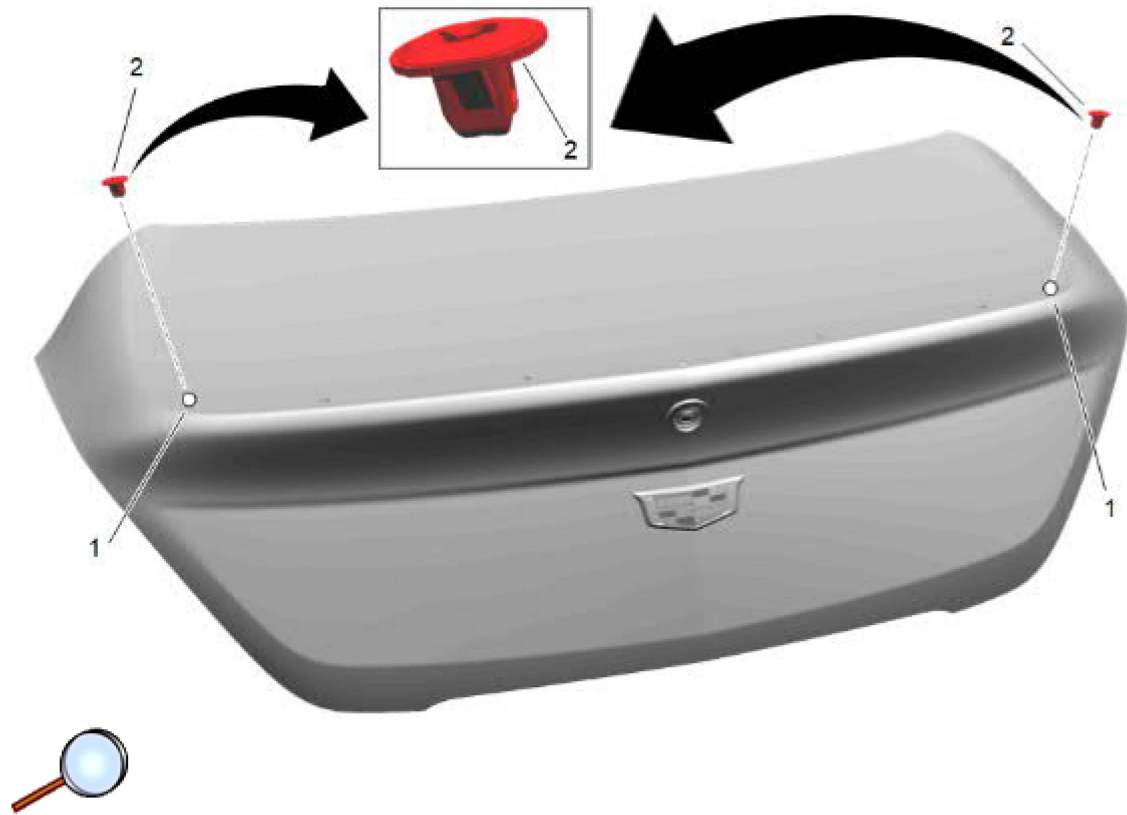

2. Insert the clips (2) into the rear compartment lid holes (1), in cross-car direction.

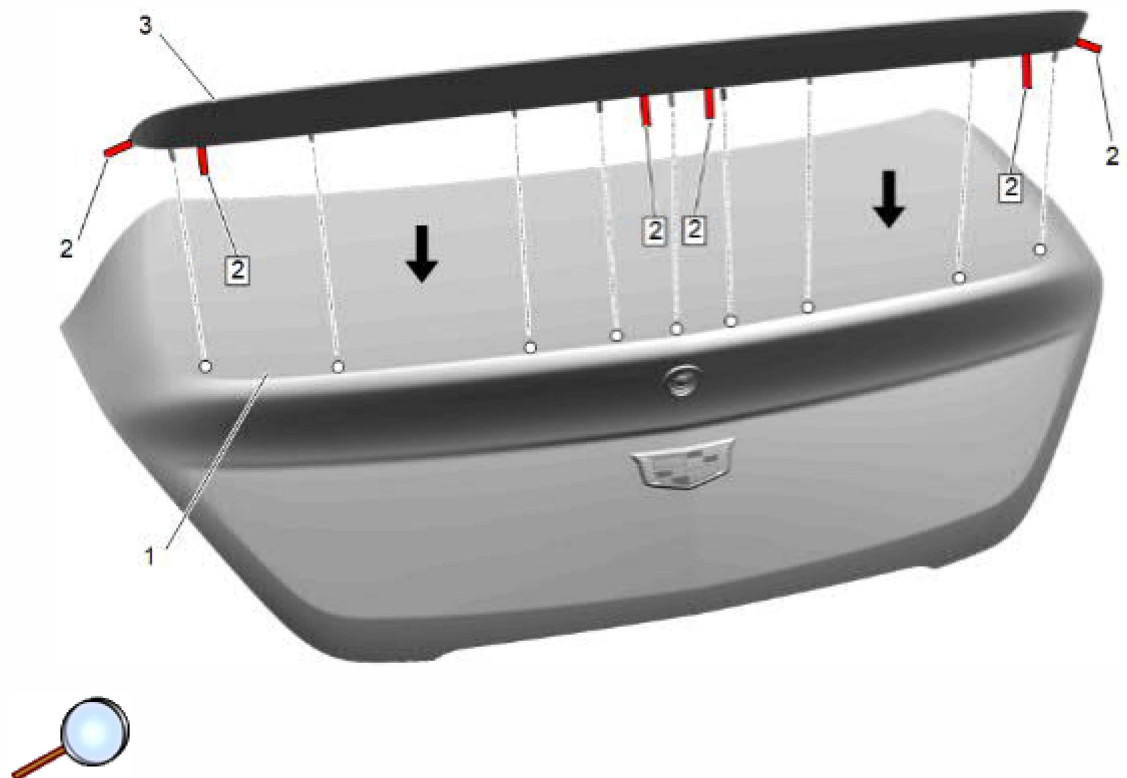

3. Start the foam/tape tabs (2) and fit the spoiler (3) to the rear compartment lid (1). Pull foam tabs, **Before** studs have completely penetrated the holes.

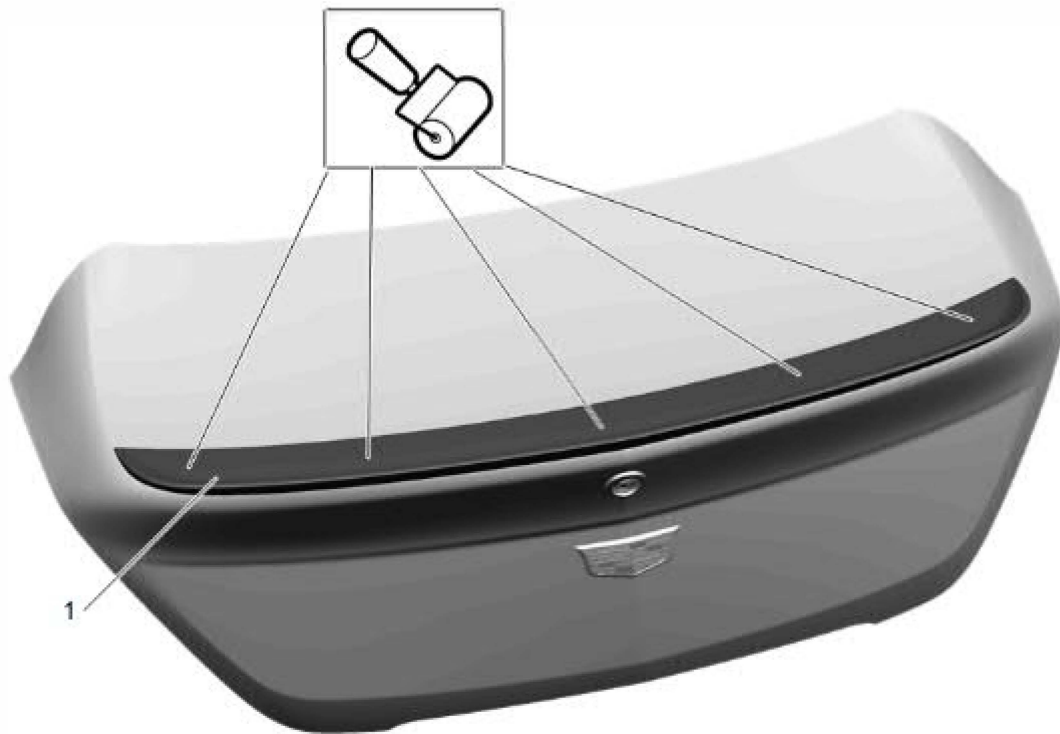

4. Apply pressure to entire spoiler surface (1). Ensure that the foam is wet out and clips engaged.

Note: Ensure that spoiler is completely wet out.

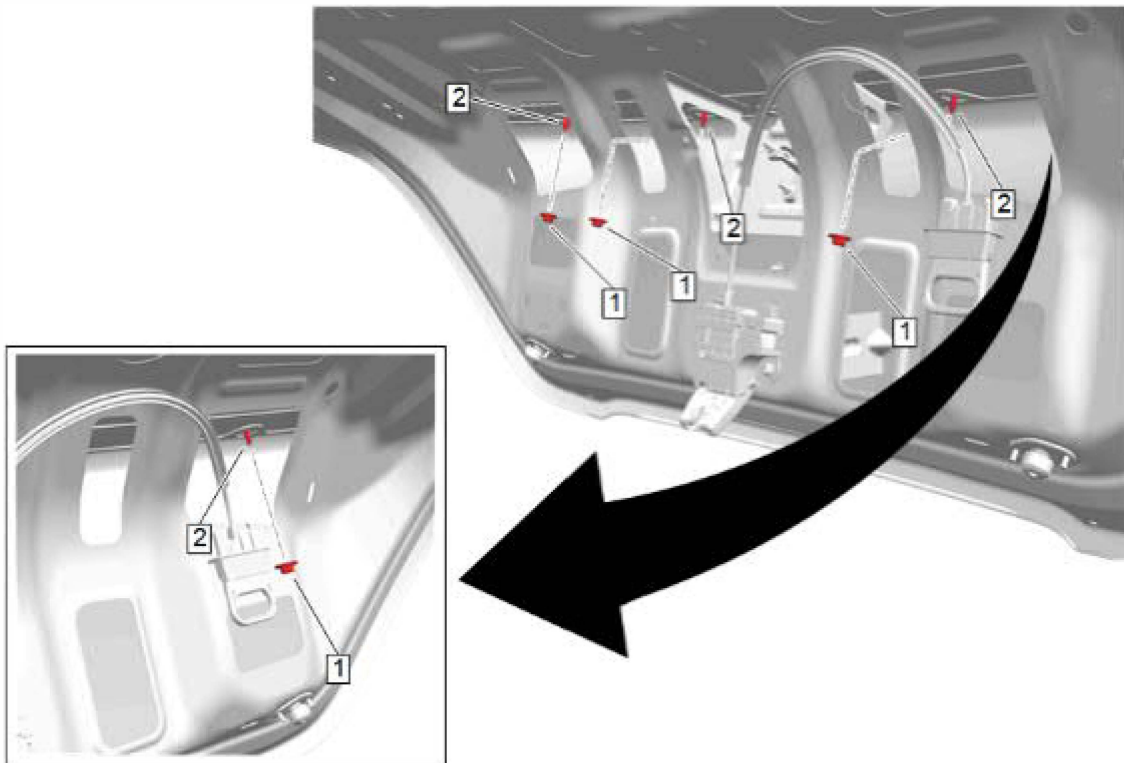

Caution: Use the correct fastener in the correct location. Replacement fasteners must be the correct part number for that application. Do not use paints, lubricants, or corrosion inhibitors on fasteners, or fastener joint surfaces, unless specified. These coatings affect fastener torque and joint clamping force and may damage the fastener. Use the correct tightening sequence and specifications when installing fasteners in order to avoid damage to parts and systems. When using fasteners that are threaded directly into plastic, use extreme care not to strip the mating plastic part(s). Use hand tools only, and do not use any kind of impact or power tools. Fastener should be hand tightened, fully seated, and not stripped.

5. From the underside of the rear compartment lid, install the nuts (1) to the studs (2). Tighten nuts to 9 N.m (6.64 lb ft).

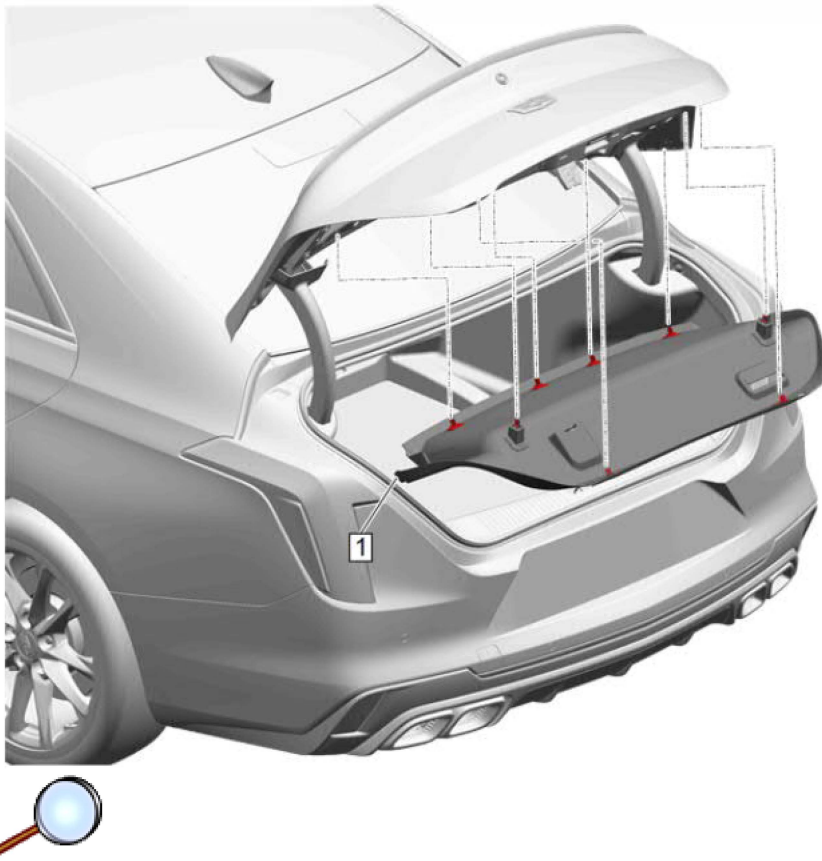

Note: Ensure the auxiliary rear compartment latch release handle is routed through the rear compartment lid inner panel trim.

6. Rear Compartment Lid Inner Panel Trim (1) » Install

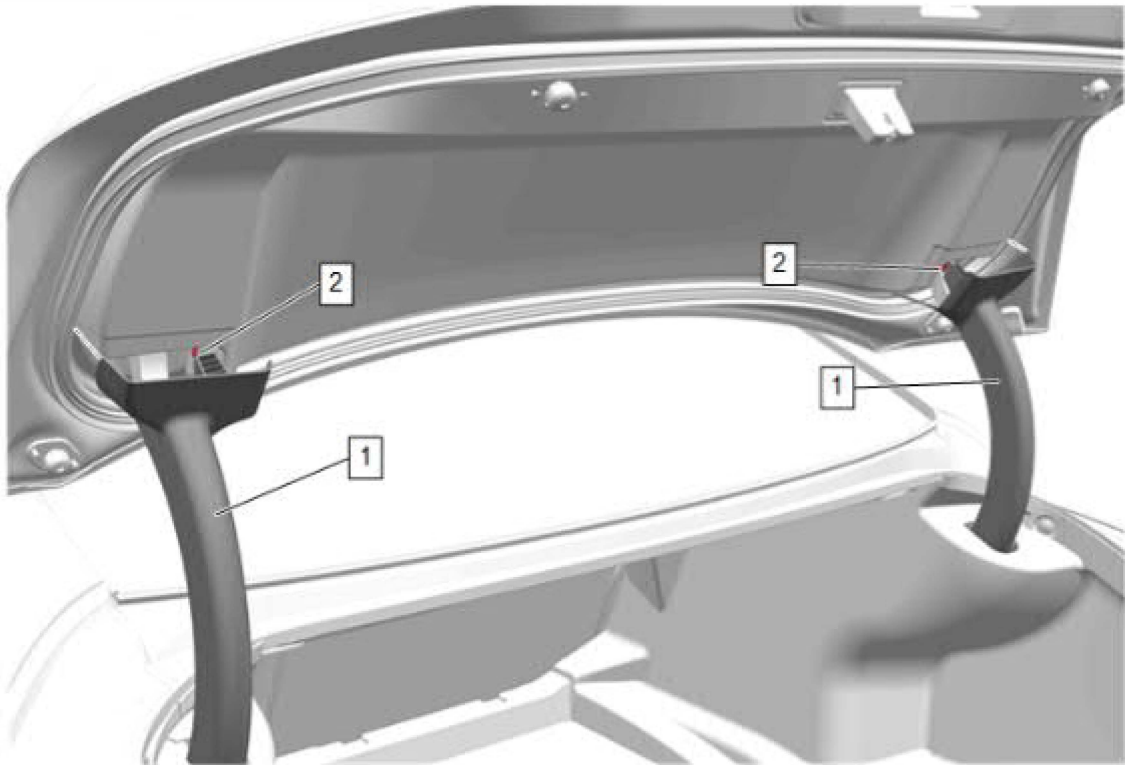

7. Rear Compartment Lid Hinge Cover (1) » Reposition [2x]



8. Rear Compartment Lid Latch Cover (1) » Install
9. Clean metal shaving debris from rear compartment floor.

