

Outside Rearview Mirror Package Installation

Table 1: [Kit Contents](#)

Table 2: [Door Harness Retrofit](#)

[Installation Instructions Part Number](#)

84558571

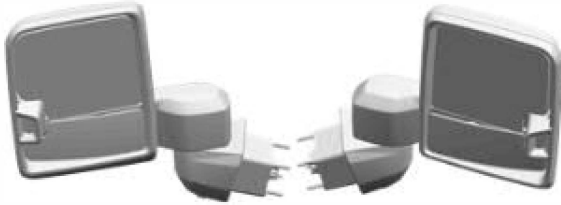

Kit Contents

Qty	Description
1	Mirror LH (New DPO"; Manual Fold, Power Adjust, Manual Extend, Heat, Clearance Lamp, Turn Signal, Cargo Lamp)
1	Mirror RH (New DPO"; Manual Fold, Power Adjust, Manual Extend, Heat, Clearance Lamp, Turn Signal, Cargo Lamp and OAT)
1	Installation Instructions
1	Authorization code (needed for BCM calibrations)

[Installation Summary](#)

- VEHICLE ACCEPTABILITY FOR RETROFIT.** Look at the following retrofit table to verify the vehicle is one of the acceptable choices for retrofit. Locate line item for customer's vehicle based on model year, body style, as-built RPOs.
- DETERMINE AND ACQUIRE NECESSARY WIRING.**
 - DOOR HARNESSSES.** Acquire/Change Driver door harness and Front Passenger's Door harness according to chart listed. **ALL trucks require new door harnesses.**
- MIRROR REPLACEMENT.** Remove the production mirrors.

Note: Be sure to save the 4 fastening M8 nuts as they will be re-used) and install the Accessory Camper mirrors in the kit.
- CALIBRATIONS.** The BCM will need new calibrations. Use the Authorization Code Label # to obtain the correct calibrations from Techline.
- FUNCTION VERIFICATION.** Follow procedure to verify all mirror functions are correct.

Retrofit Plan for Camper Mirrors (S4Z)

RPO descriptions: DLF= Factory Mirror, DPO= Camper Mirror, BTM= PEPS (Keyless Start).

Door Harness Retrofit

VEHICLE	CABIN STYLE	"AS BUILT" RPOs	Install new Door with:	Install Driver Door Harness	Install Passenger Door Harness	BCM need new Cals (for T/S, Clearance Lp, Cargo Lp)?
2020 LD	Dbi Cab (53) Crew Cab (43)	DLF-BTM (w/o PEPS)	DPO-BTM (w/o PEPS)	84622369	84622370	YES
	Regular Cab (03)			84622376	84622380	
	Dbi Cab (53) Crew Cab (43)	DLF & BTM (PEPS)	DPO & BTM (PEPS)	84622371	84622372	
2021 LD 2022 LD (LCI)	Dbi Cab (53) Crew Cab (43)	DLF-BTM (w/o PEPS)	DPO-BTM (w/o PEPS)	84622369	84622370	
	Regular Cab (03)			84622376	84622380	
	Dbi Cab (53) Crew Cab (43)	DLF & BTM (PEPS)	DPO & BTM (PEPS)	84622371	84622372	

VEHICLE ACCEPTABILITY FOR RETROFIT

Verify the vehicle has option content which agrees with one of the line items on the Retrofit Plan chart above. **ALL trucks require new door harnesses.**

Note: The Camper mirrors can only be placed on vehicles that have DLF factory mirrors without Task Lamps (U12) and without Lane Change Alert (UKC). The camper mirrors will NOT function on a vehicle originally built with factory built DEN or DEZ mirrors.

Procedure to install S42 Kit:

DOOR HARNESES

Use the retrofit table to determine what part numbers to order for the two front door harnesses. Install new harnesses, replacing factory harnesses. Refer to [Front Side Door Wiring Harness Replacement](#) in Vehicle Service manual for door harness replacement information.

Outside Rearview Mirror Replacement

1. Remove the front side door trim. Refer to [Front Side Door Trim Replacement](#) in Vehicle Service Manual.

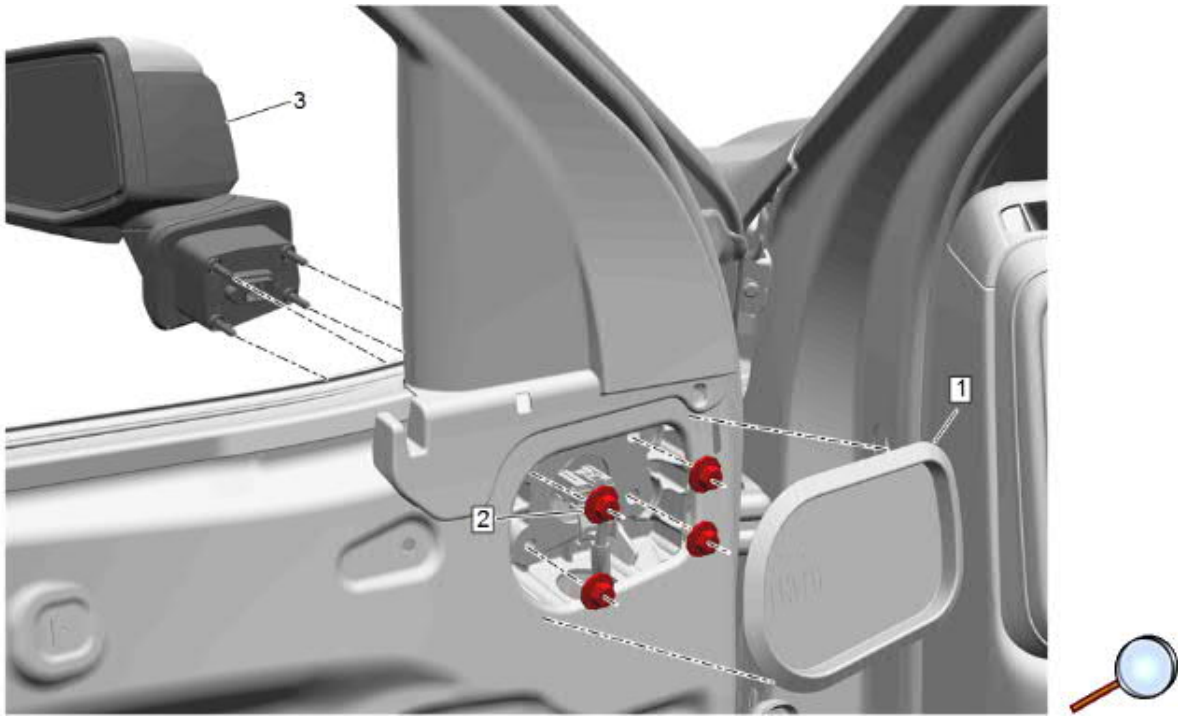

Warning: Refer to [Glass and Sheet Metal Handling Warning](#).

2. Remove the rearview mirror nut access hole plug (1).
3. Remove and retain the four nuts (2) from the production installed mirror.
4. Disconnect the electrical connector and remove production installed mirror (3) from door.

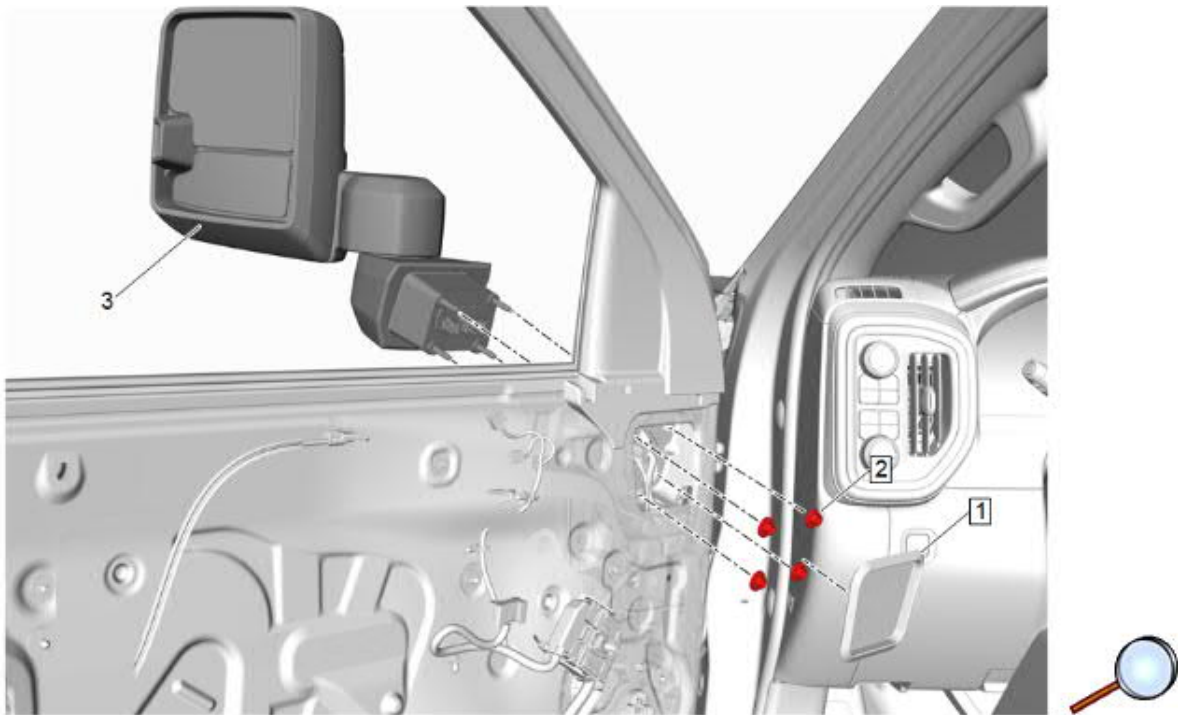

Caution: Use the correct fastener in the correct location. Replacement fasteners must be the correct part number for that application. Fasteners requiring replacement or fasteners requiring the use of thread locking compound or sealant are identified in the service procedure. Do not use paints, lubricants, or corrosion inhibitors on fasteners or fastener joint surfaces unless specified. These coatings affect fastener torque and joint clamping force and may damage the fastener. Use the correct tightening sequence and specifications when installing fasteners in order to avoid damage to parts and systems.

5. Install the camper mirror (3) into the door slot where the production mirror was removed. Install the four previously retained nuts (2) to the mirror and torque to 22 N.m (16 lb ft).
6. Using the selected door wiring harness (previously installed), connect the electrical connector to mirror.
7. Re-install the rearview mirror nut access hole plug (1).
8. Re-install the front side door trim. Refer to [Front Side Door Trim Replacement](#) in Vehicle Service Manual.

CALIBRATIONS

With the support of the Tech Line, download the new BCM calibration to support the new Camper Mirror lighting features.

The BCM must be reprogrammed to enable all the capabilities of the Camper Mirrors.

Reference the Serial Number on the outside of the kit box, and the Authorization Code Label on the 1- page instruction sheet in the box.

Note: The installation of this accessory update kit requires programming and configuring of the vehicle. This is done with a Service Programming System (SPS-TIS2WEB). Call TCSC: United States 1-888-337-1010 Canada (English) 1-800-828-6860 Canada (French) 1-800-503-3222. The Techline Customer Support Center will provide programming instructions and changes to the vehicles calibration settings. You must provide the vehicle identification number (VIN) of the vehicle to be programmed and the authorization code when calling TCSC.

Using the Scan Tool with a MDI, and (SPS-TIS2WEB), update the BCM calibration to activate the Camper Mirror features.

FINAL VERIFICATION

With both accessory camper mirrors installed, test the mirror functionality, and check for any diagnostic codes.

- A.** Glass Movement
- B.** Heat
- C.** Clearance Lamps (on with Park Lamps)
- D.** Turn Signals
- E.** Cargo Lamps (to illuminate with roof mounted cargo lamps when I/P switch is engaged).
- F.** Outside Air Temp readings (in I/P display; the OAT sensor is located in the Passenger's mirror).

Note: Camper Mirrors are MANUAL FOLD and MANUAL EXTEND.