

# Front Fender Mud Flap Package Installation (Instruction ID: 84649175)

## Installation Instructions Part Number

84649175

**Note:** Please read instructions thoroughly before starting.

### Front Fender Mud Flap Kit Contents

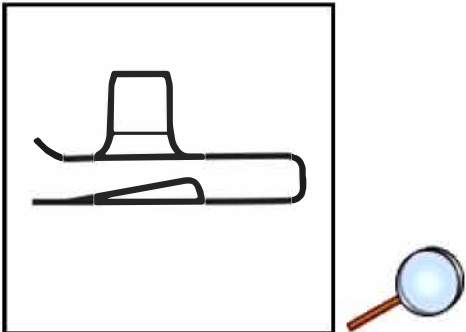
Qty	Description
1	Left Hand Splash Guard
1	Right Hand Splash Guard
4	M4.2 x 20 Screw with Washer
2	 M4.2 U-nut (large throat)
2	M4.2 U-nut (small throat)
1	Instruction Sheet

### Tools Required

**Note:** Do not use power tools to install fasteners.

- T15 Screw Driver
- Ratchet
- Pliers
- 10 mm Hex Socket
- Drill with 13/64" (5.0mm) Drill Bit
- Clean Cloth/Rag
- GM Vehicle Care Super Lube with PTFE
- Torque Wrench with T15 Head

### Installation Procedure

**Note:** If the wheel liner and the splash guards are being installed at the same time. Wheel Liner must be installed first and then the splash guard.

1. Turn front wheel/tire to provide clearance.
2. Clean and degrease body panel where splash guards will be located.

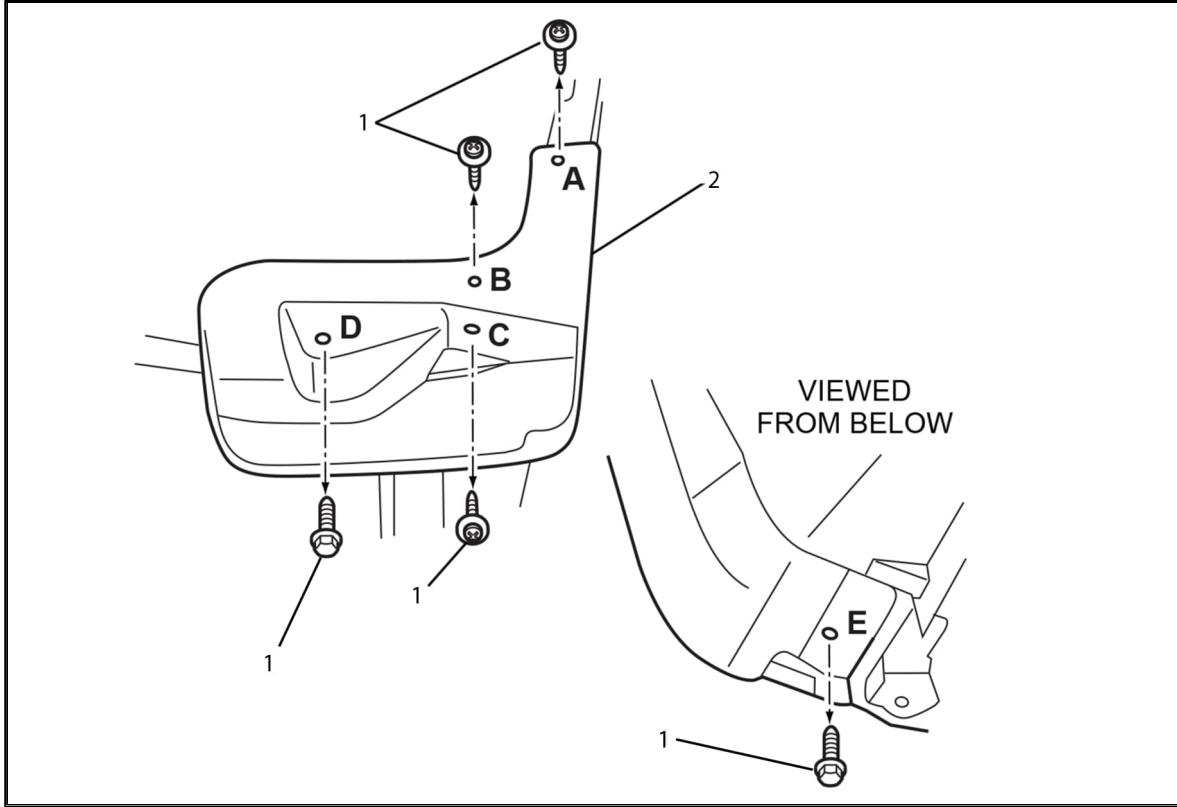

- Remove existing screws (1) at locations (A), (B), (C), (D) and (E) and remove stone protector (2). Retain fasteners from locations (A), (B) and (E). Re-install fasteners from location (C) and (D) onto vehicle sheet metal.

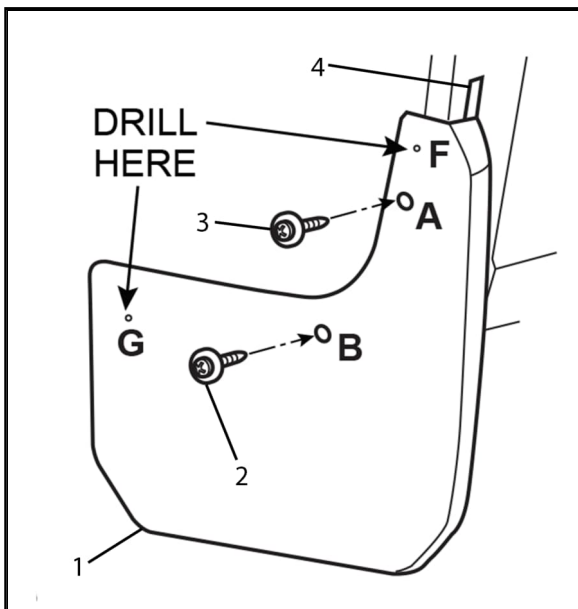

**Caution:** Use the correct fastener in the correct location. Replacement fasteners must be the correct part number for that application. Fasteners requiring replacement or fasteners requiring the use of thread locking compound or sealant are identified in the service procedure. Do not use paints, lubricants, or corrosion inhibitors on fasteners or fastener joint surfaces unless specified. These coatings affect fastener torque and joint clamping force and may damage the fastener. Use the correct tightening sequence and specifications when installing fasteners in order to avoid damage to parts and systems.

- Place splash guard (1) to vehicle taking care to remove any gaps, make sure red tape pull tab (4) is accessible, and install retained M4.2 X 20 screws with washers (2), (3) at locations (A) and (B). Tighten M4.2 screws to 3.0 N.m.
- While holding splash guard firmly to vehicle, take care to remove any gaps, drill a 13/64" (5.0mm) hole through the fender at location (F) and wheel liner location (G). Location (G) should be drilled through splash guard and wheel liner. Remove splash guard. Generously coat drilled hole (F) with GM Vehicle Care Super Lube with PTFE to help with corrosion prevention.

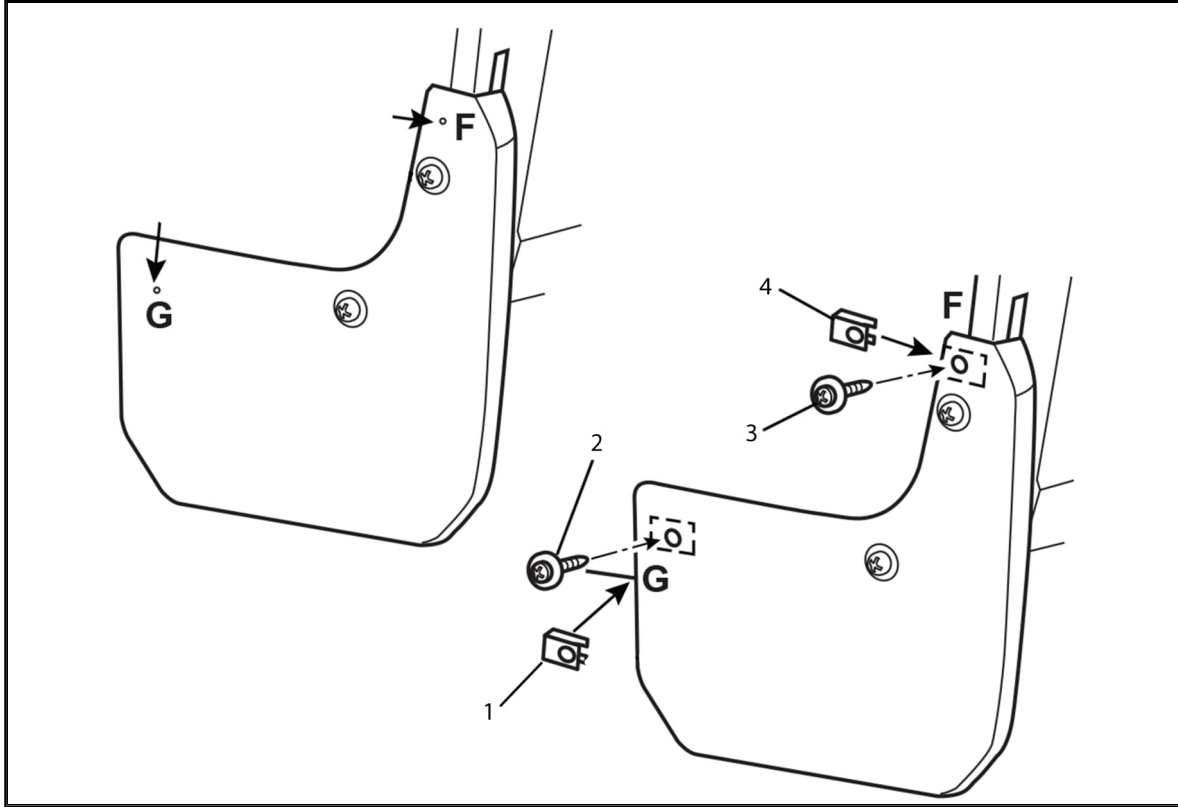

6. Install supplied U-nut (4) onto sheet metal at newly drilled hole at location (F) and reinstall splash guard.
7. Generously apply GM Vehicle Care Super Lube with PTFE to threads and nose of supplied M4.2 screw w/ washer (3) and install at location (F). Tighten M4.2 screw to 3.0 N.m.
8. Install supplied M4.2 screw w/ washer (2) and U-nut (1) at location (G). The U-nut (1) should be installed as a nut behind the wheel liner. Tighten M4.2 screw to 3.0 N.m.

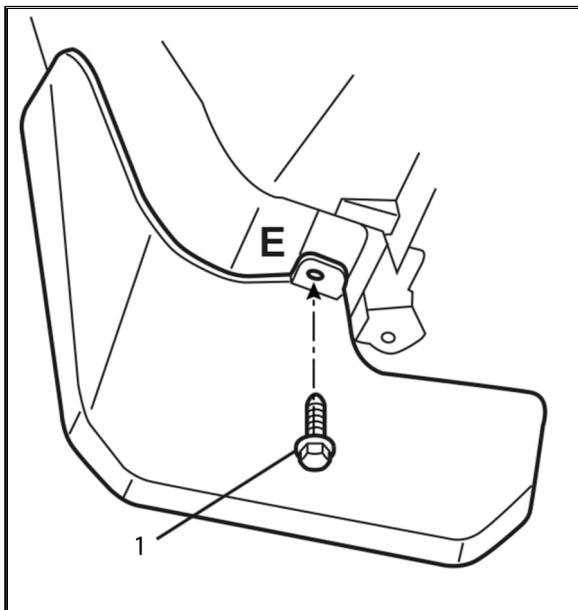

9. Pull splash guard tab rearward and inward to align tab hole to vehicle hole at location (E). Take care to ensure there are no gaps. Reinstall retained fastener (1) from location (E). Tighten fastener to 3.0 N.m.

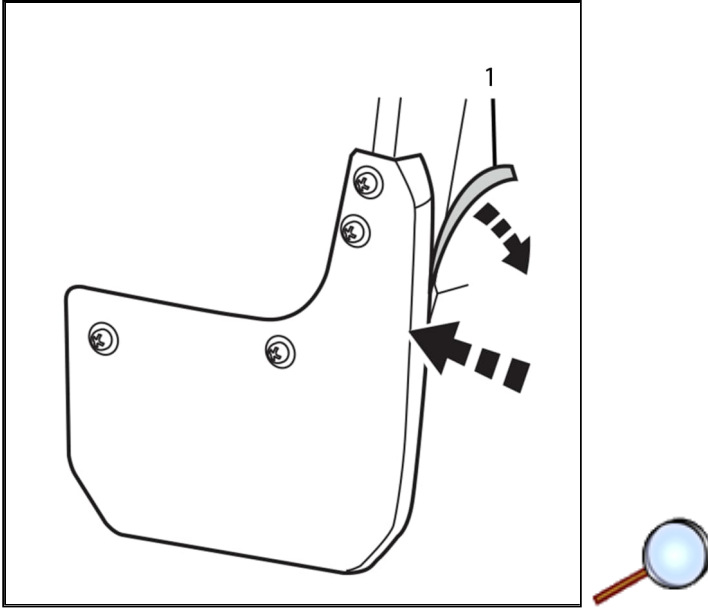

10. Remove tape liner (1) and apply firm pressure to the splash guard along the tape line to adhere the tape to the fender. Hold firm pressure for a minimum of 60 seconds to properly adhere the tape.
11. Repeat for other side.
12. Guards can be cleaned with any commercially available cleaner.