

# Cadillac CT4 | Document ID: 5549520

## Body Emblem Package Installation (Instruction ID: 84670236)

### Installation Instructions Part Number

84670236

### Kit Contents

Qty	Description
1	Emblem Assembly – Front
1	Emblem Assembly – Rear Compartment Lid
1	Alcohol Wipe
1	Installation Instructions

### Tools Required

Flat bladed plastic trim tool

Masking tape

### Procedure

#### Remove Front Emblem

1. Read all instructions before performing procedure.
2. Inspect kit to verify all parts are included.
3. Turn off the vehicle.
4. Open hood.
5. Raise and support the vehicle. Refer to [Lifting and Jacking the Vehicle](#) in Vehicle Service Manual.

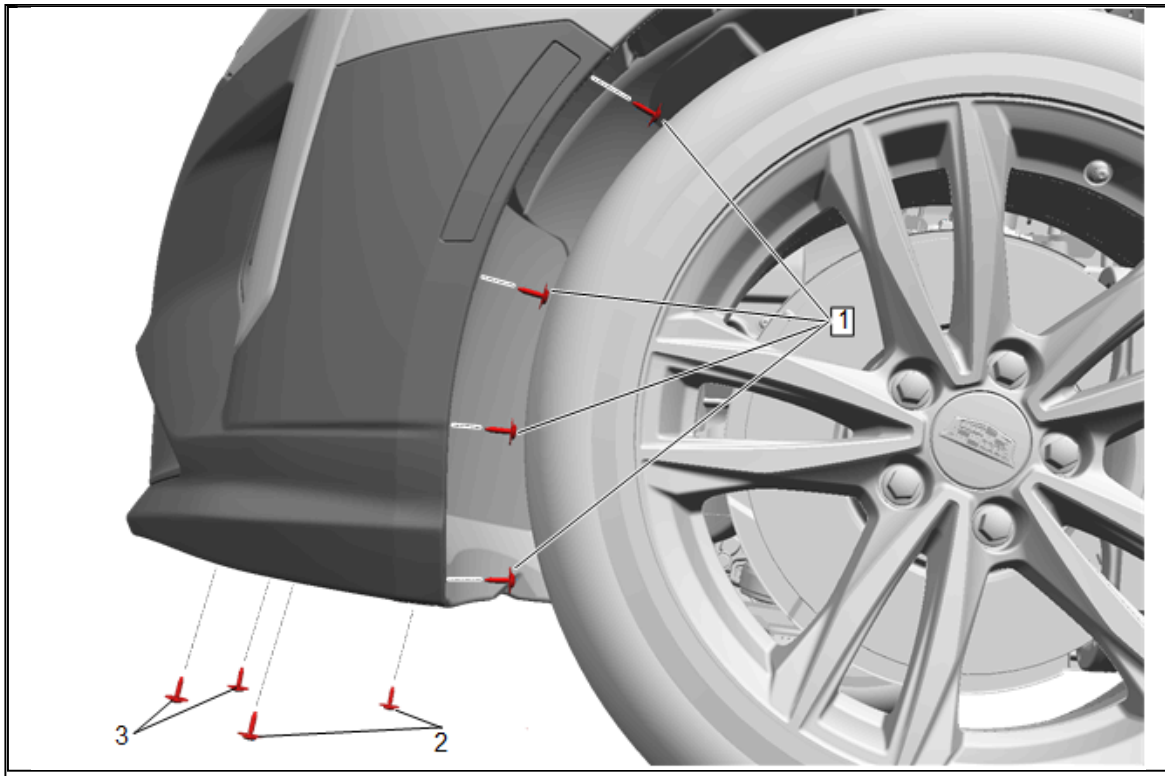

- 6. Front Wheelhouse Liner Bolt - Left Side (1) » Remove [4x]
- 7. Front Tire Front Air Deflector Bolt - Left Side (2) » Remove [2x]
- 8. Front Bumper Fascia Bolt - Left Side (3) » Remove [2x]

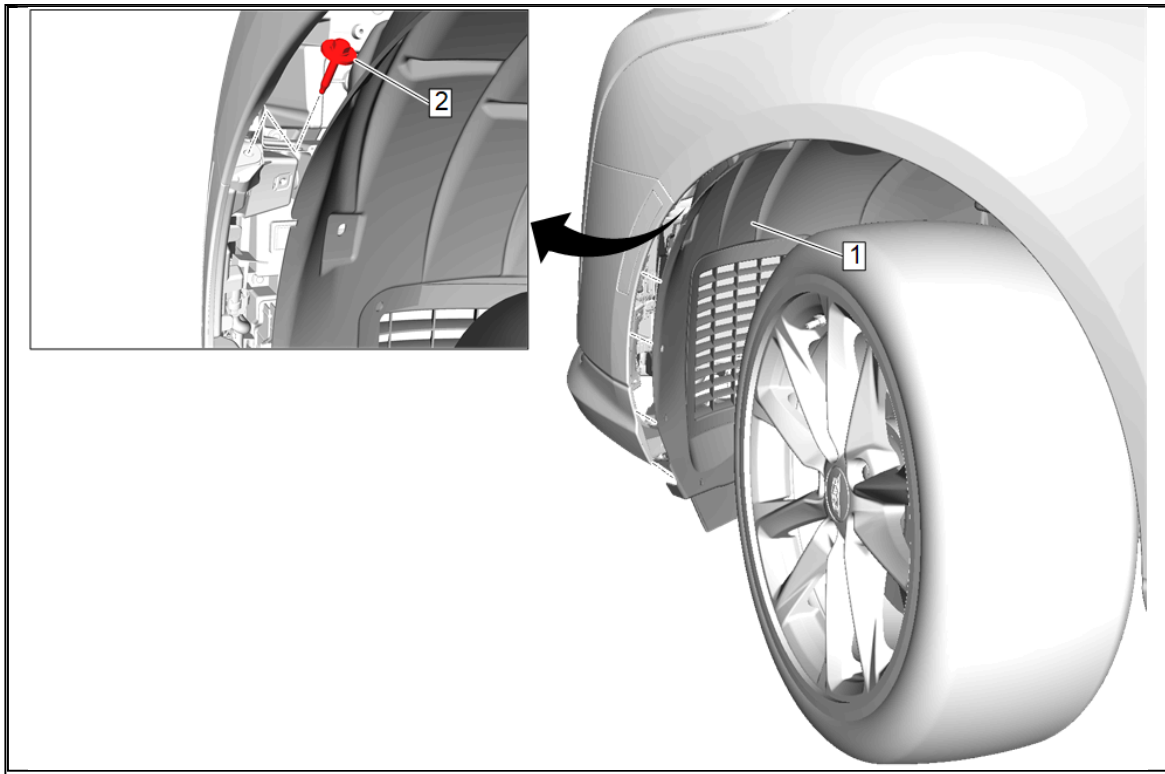

9. Reposition the left front wheelhouse liner (1) to gain access to the left side upper front bumper fascia bolt (2).
10. Remove the left side upper front bumper fascia bolt (2).

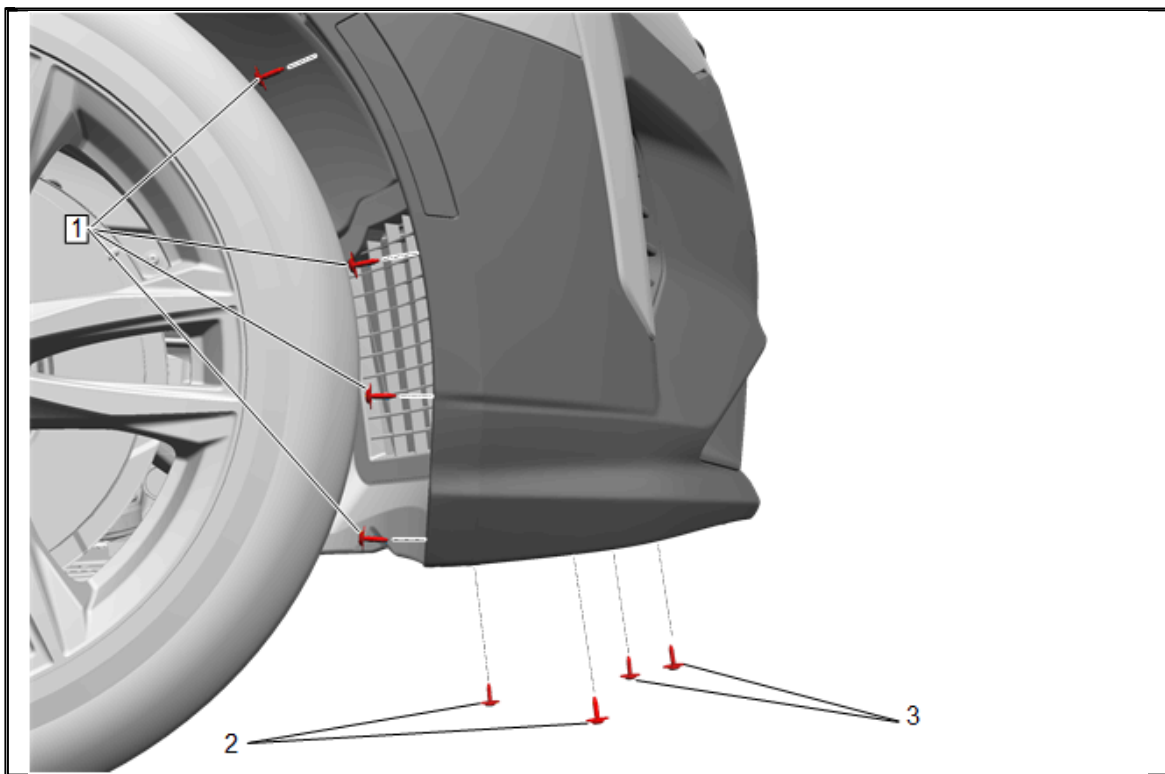

11. Front Wheelhouse Liner Bolt - Right Side (1) » Remove [4x]
12. Front Tire Front Air Deflector Bolt - Right Side (2) » Remove [2x]
13. Front Bumper Fascia Bolt - Right Side (3) » Remove [2x]

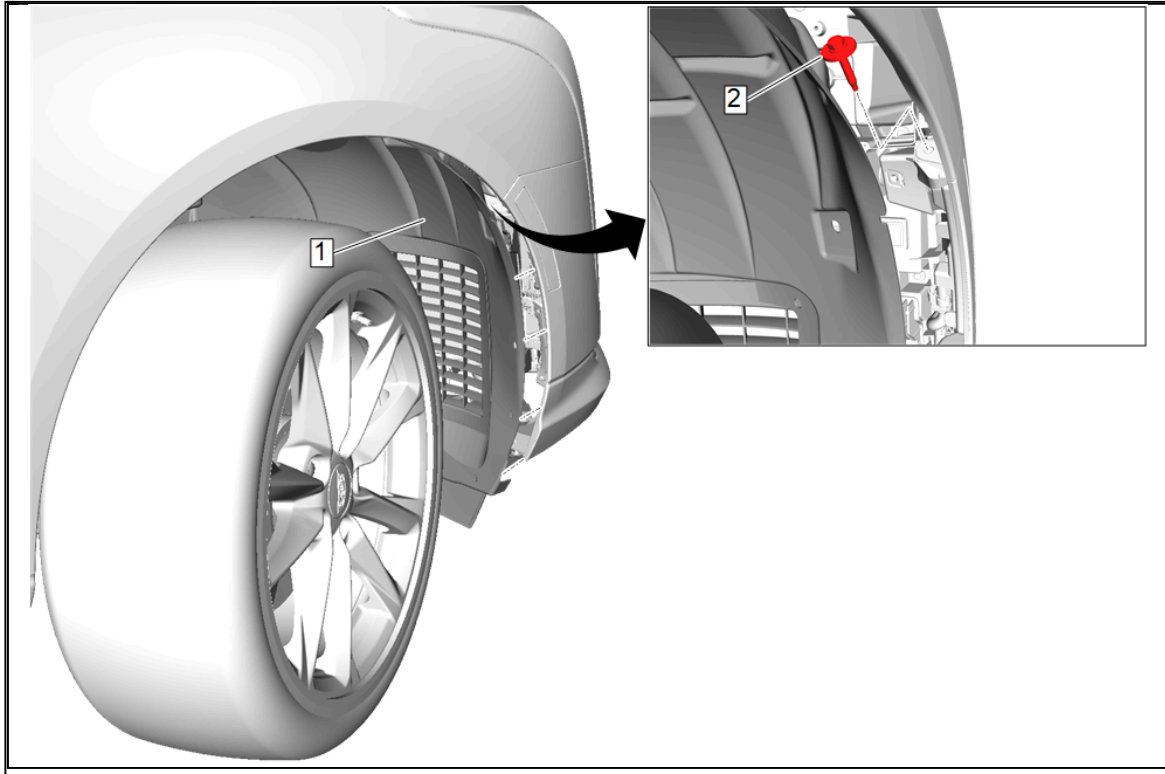

14. Reposition the right front wheelhouse liner (1) to gain access to the right side upper front bumper fascia bolt (2).
15. Remove the right side upper front bumper fascia bolt (2).

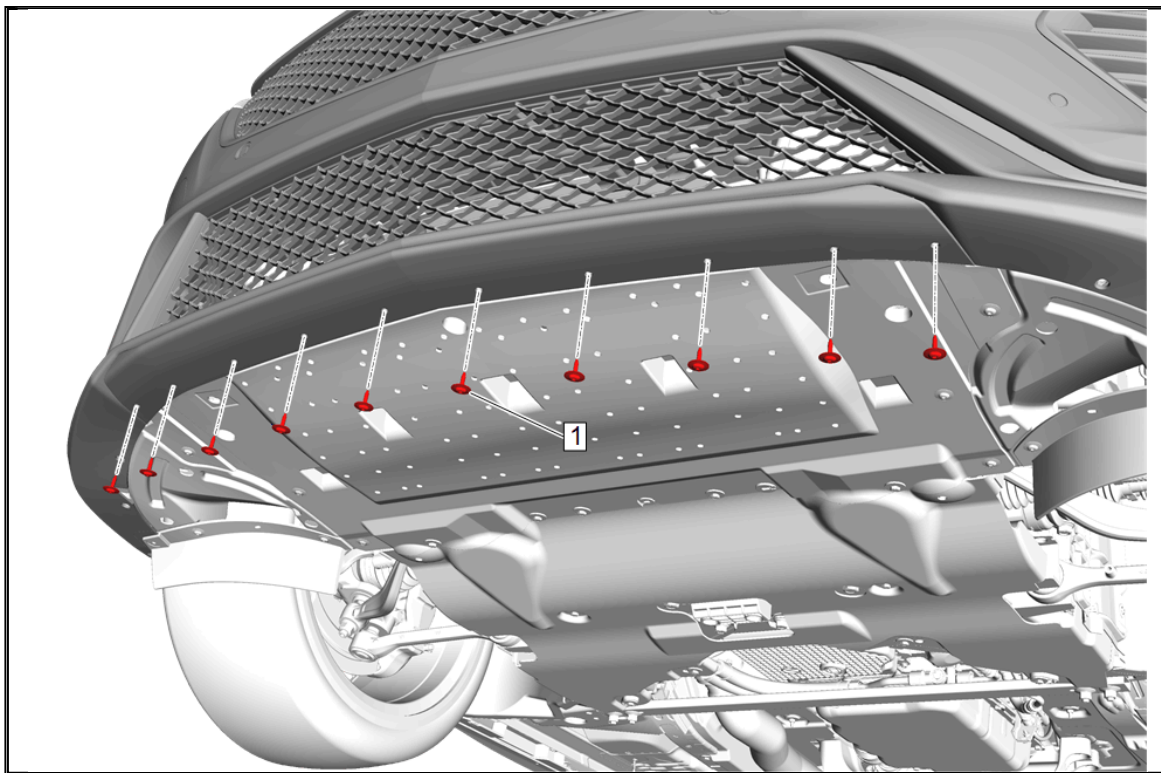

16. Front Bumper Fascia Center Air Deflector Screw (1) » Remove [10x]

17. Remove the support and lower the vehicle.

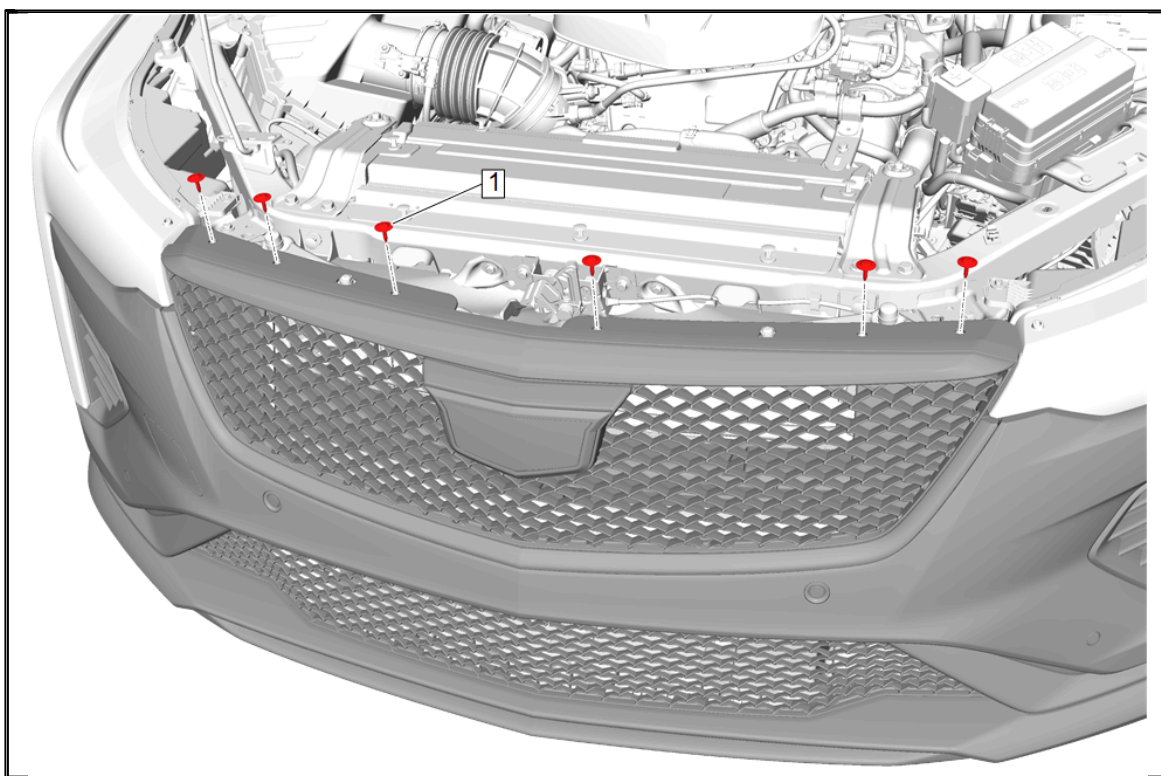

### 18. Front Bumper Fascia Bolt (1) » Remove [6x]

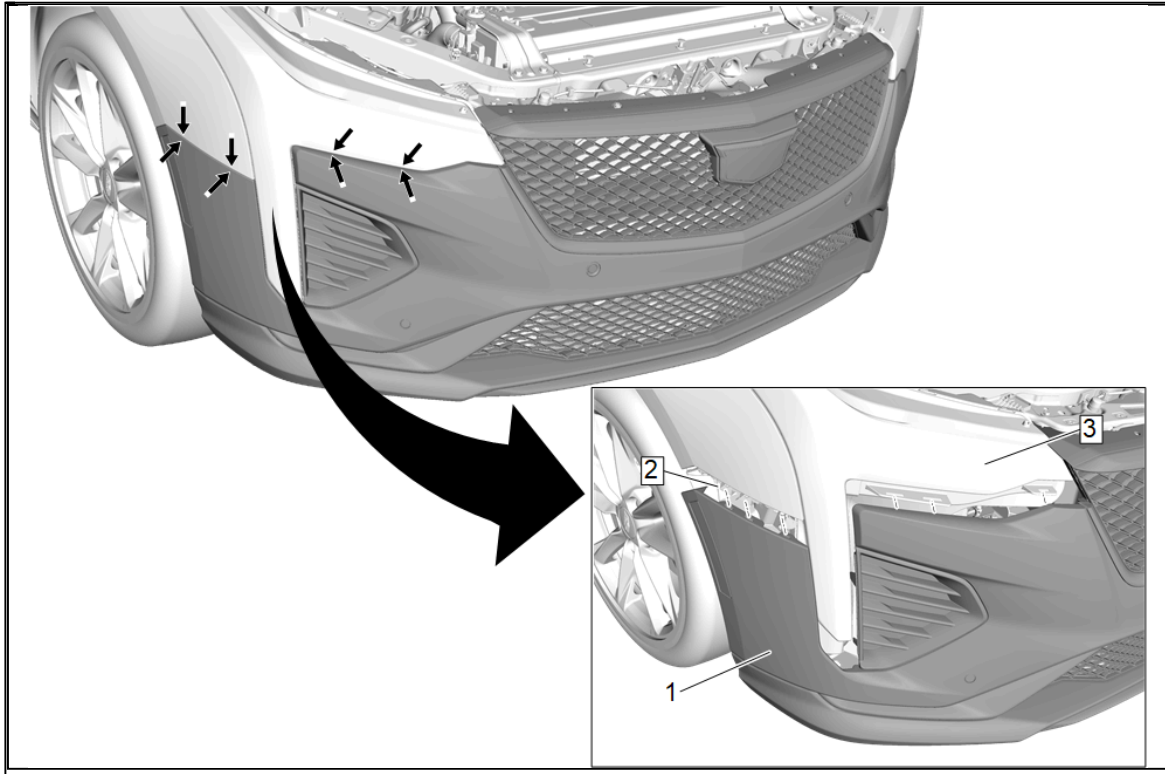

19. On the right side of the front bumper fascia carefully push a small nylon wedge between the front bumper fascia (1), the front bumper fascia guide (2), and the front headlamp (3). Insert a suitable flat-bladed plastic trim tool into the fascia slot and depress the snaps one at a time and pull on the fascia at the same time to gradually remove the right side of the front bumper fascia.

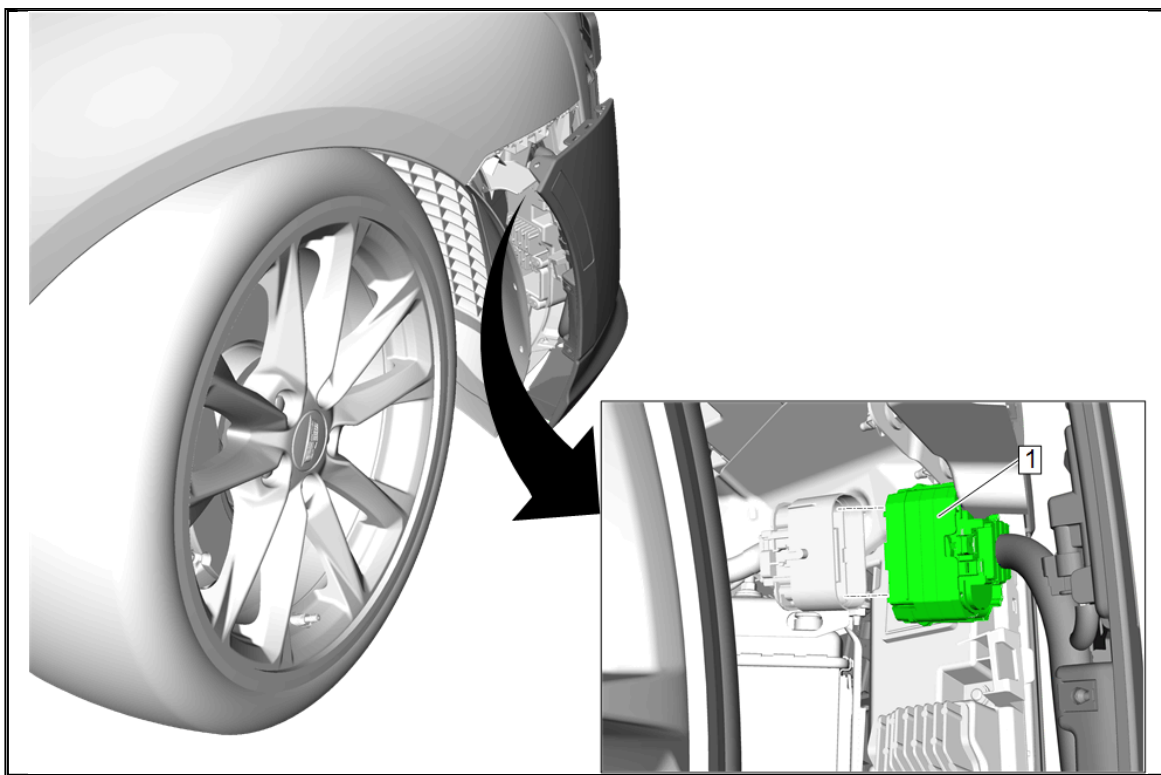

20. Reposition the front bumper fascia on the right side to gain access to the electrical connector (1).
21. Disconnect the electrical connector.

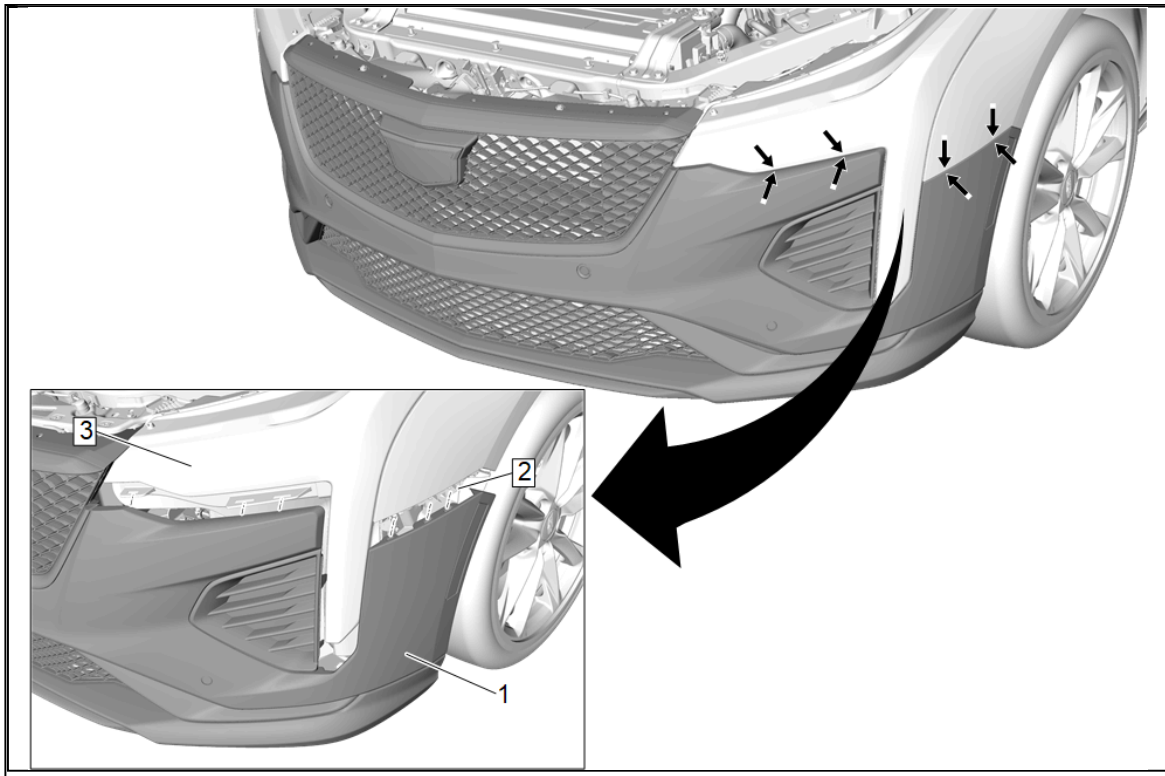

22. On the left side of the front bumper fascia carefully push a small nylon wedge between the front bumper fascia (1), the front bumper fascia guide (2), and the front headlamp (3). Insert a suitable flat-bladed plastic trim tool into the fascia slot and depress the snaps one at a time and pull on the fascia at the same time to gradually remove the left side of the front bumper fascia.

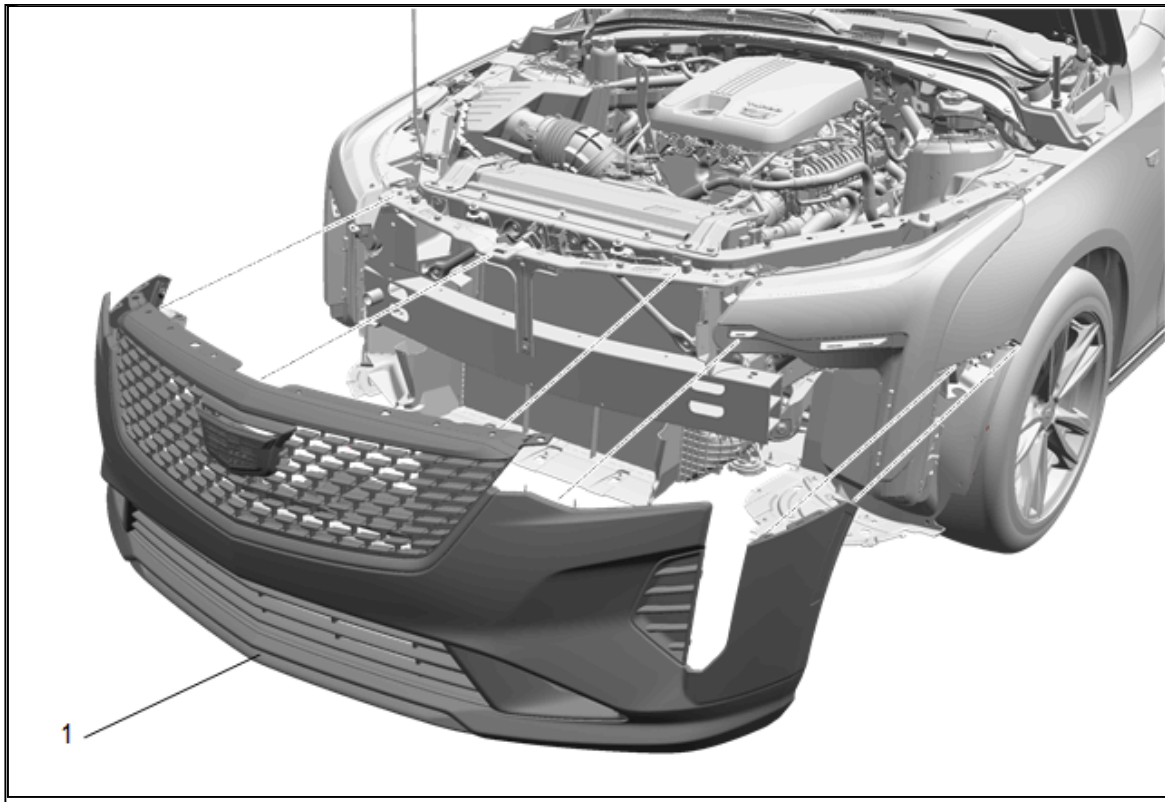

23. With the aid of an assistant, remove the fascia. (1)
24. Place the front bumper fascia on a clean suitable work surface to prevent damage.
- Note:** This step is only necessary if vehicle is equipped with front bumper shutter.
25. Reposition the front bumper fascia wiring harness.

### **Front Bumper Shutter**

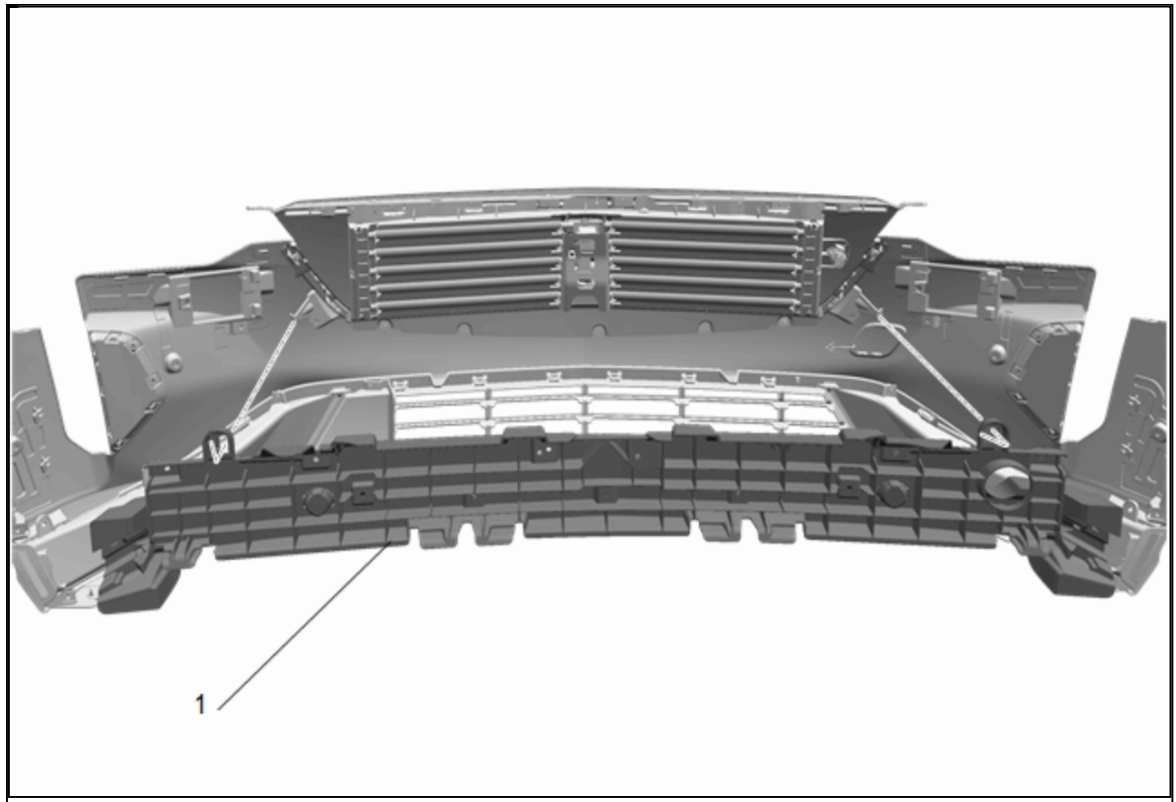

25.1. Release the retainer tabs on the front bumper fascia and pull the energy absorber (1) from the front bumper fascia.

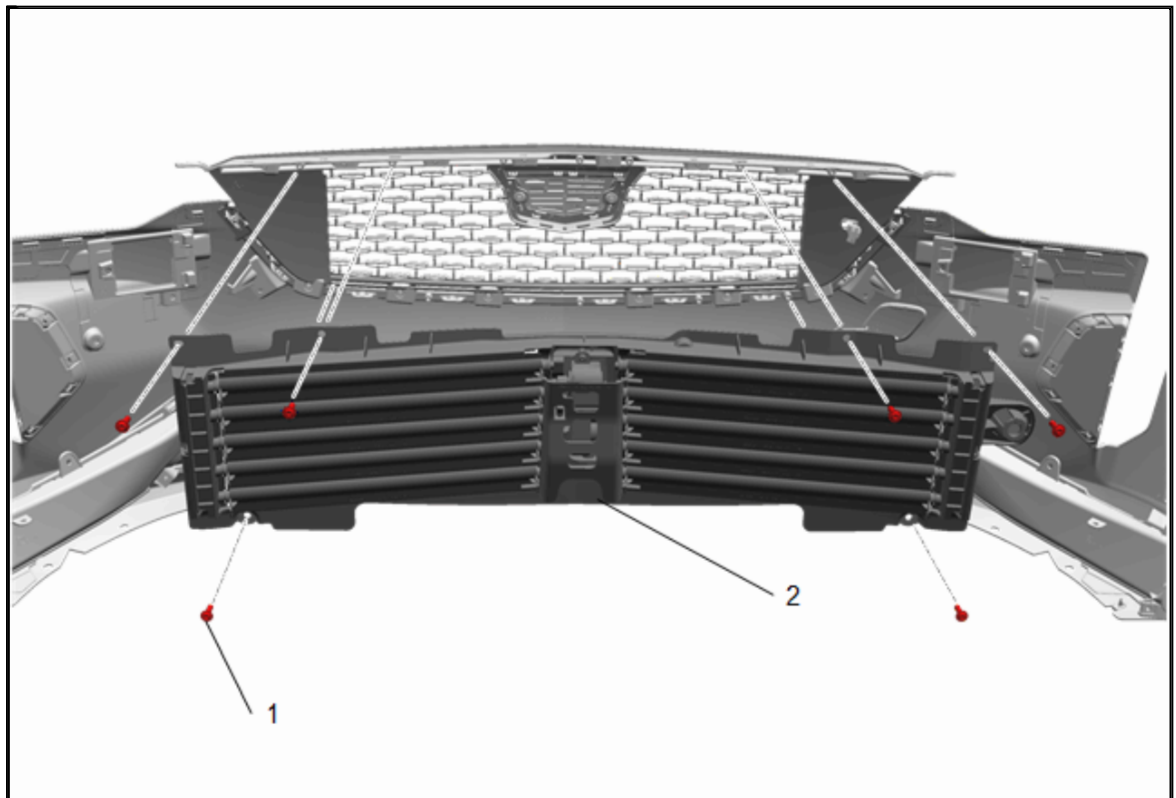

25.2. Disconnect the electrical connectors.

25.3. Front Bumper Shutter Bolt (1) » Remove [6x]

25.4. Front Bumper Shutter (2) » Remove

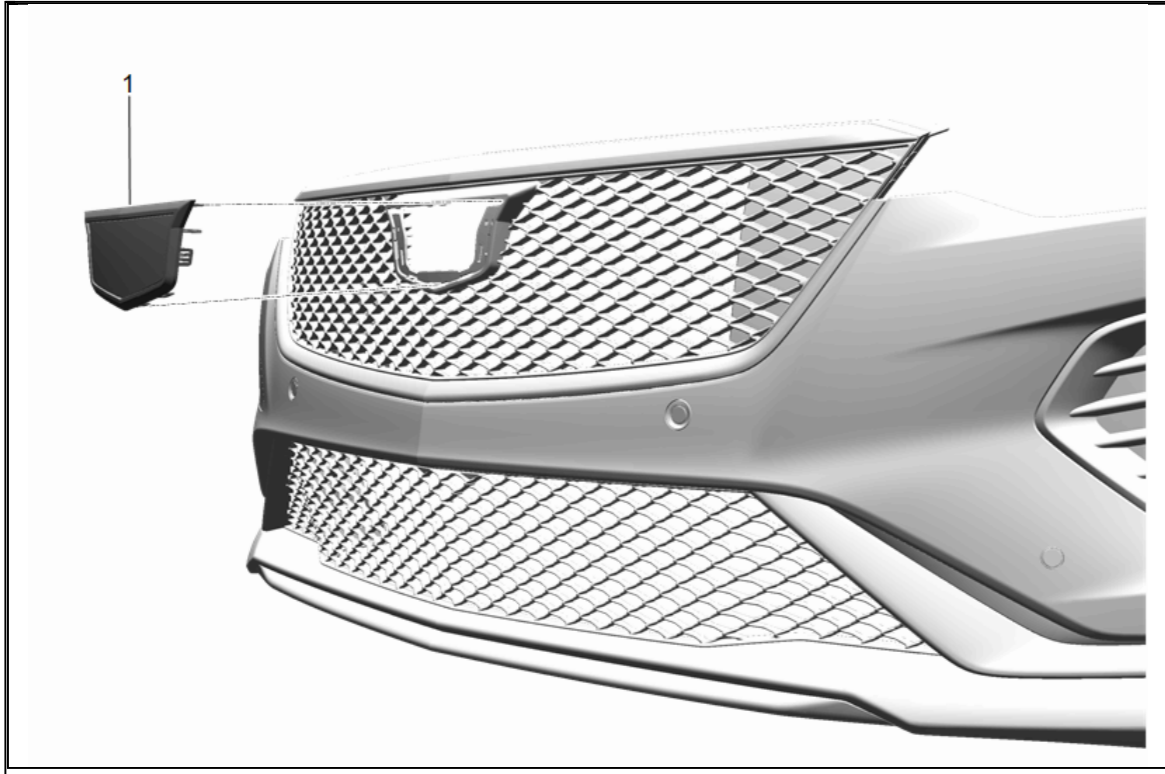

26. Release the front grille emblem/nameplate (1) retaining tabs and push the emblem/nameplate through the front grille.

27. Front Grille Emblem/Nameplate (1) » Remove

### **Install Front Emblem**

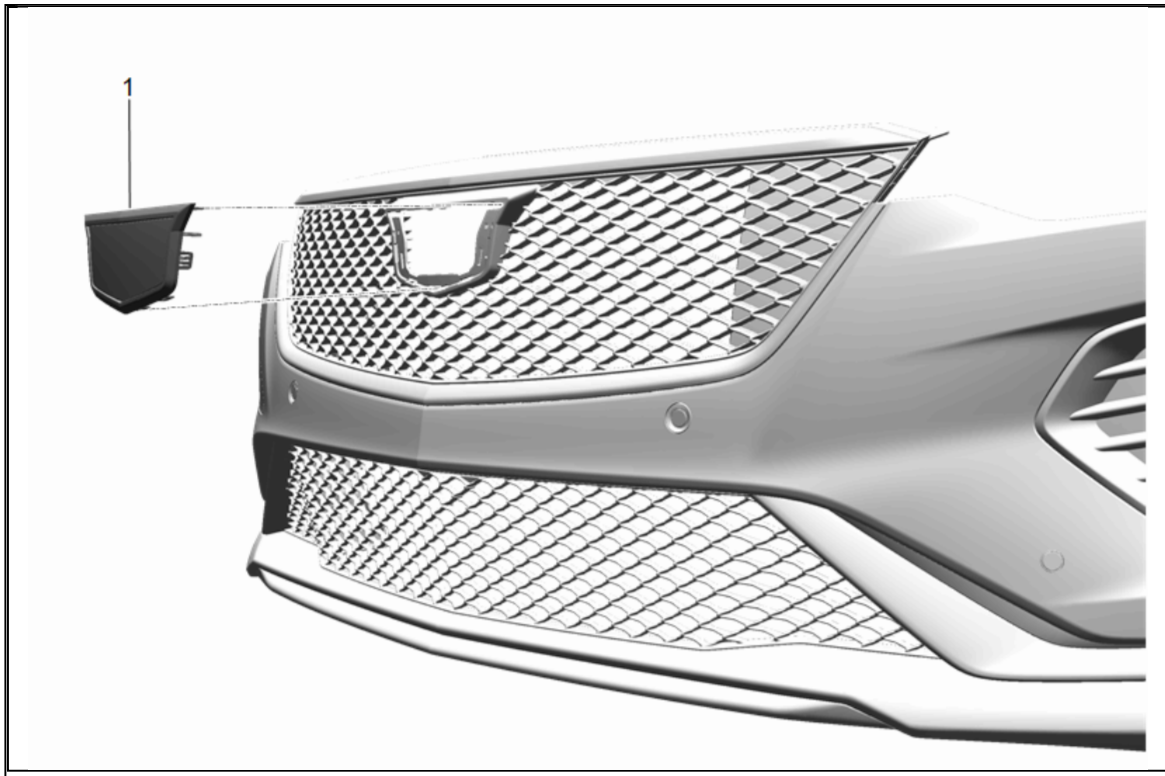

1. Accurately position the new front grille emblem (1) to the front grille and engaging the locking tabs.
2. Apply enough evenly distributed pressure to engage the locking/retention tabs.  
**Note:** This step is only necessary if vehicle is equipped with front bumper shutter.
3. Position the front bumper shutter frame to the front bumper fascia and connect the electrical connector.

### **Front Bumper Shutter**

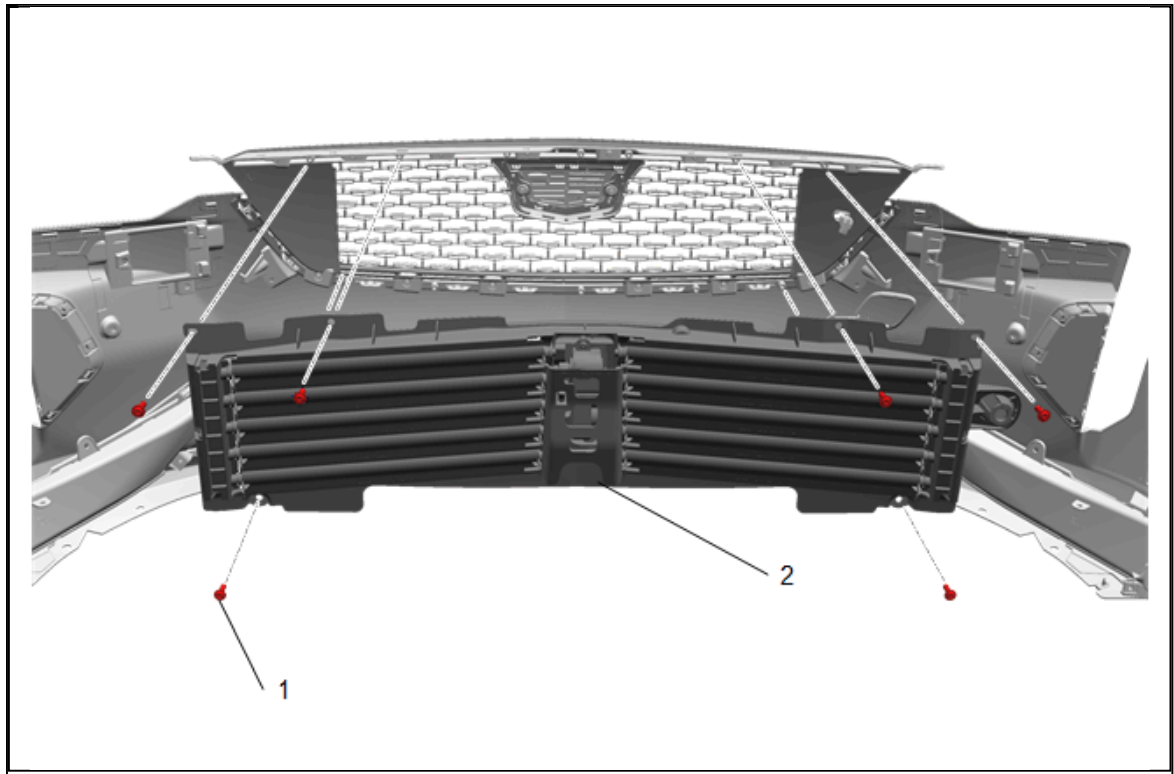

### 3.1. Front Bumper Shutter (2) » Install

**Caution:** Use the correct fastener in the correct location. Replacement fasteners must be the correct part number for that application. Fasteners requiring replacement or fasteners requiring the use of thread locking compound or sealant are identified in the service procedure. Do not use paints, lubricants, or corrosion inhibitors on fasteners or fastener joint surfaces unless specified. These coatings affect fastener torque and joint clamping force and may damage the fastener. Use the correct tightening sequence and specifications when installing fasteners in order to avoid damage to parts and systems.

### 3.2. Front Bumper Shutter Bolt (1) » Install and tighten [6x] — Tighten bolts to 4.7 N.m (42 lb in).

### 3.3. Connect the electrical connectors.

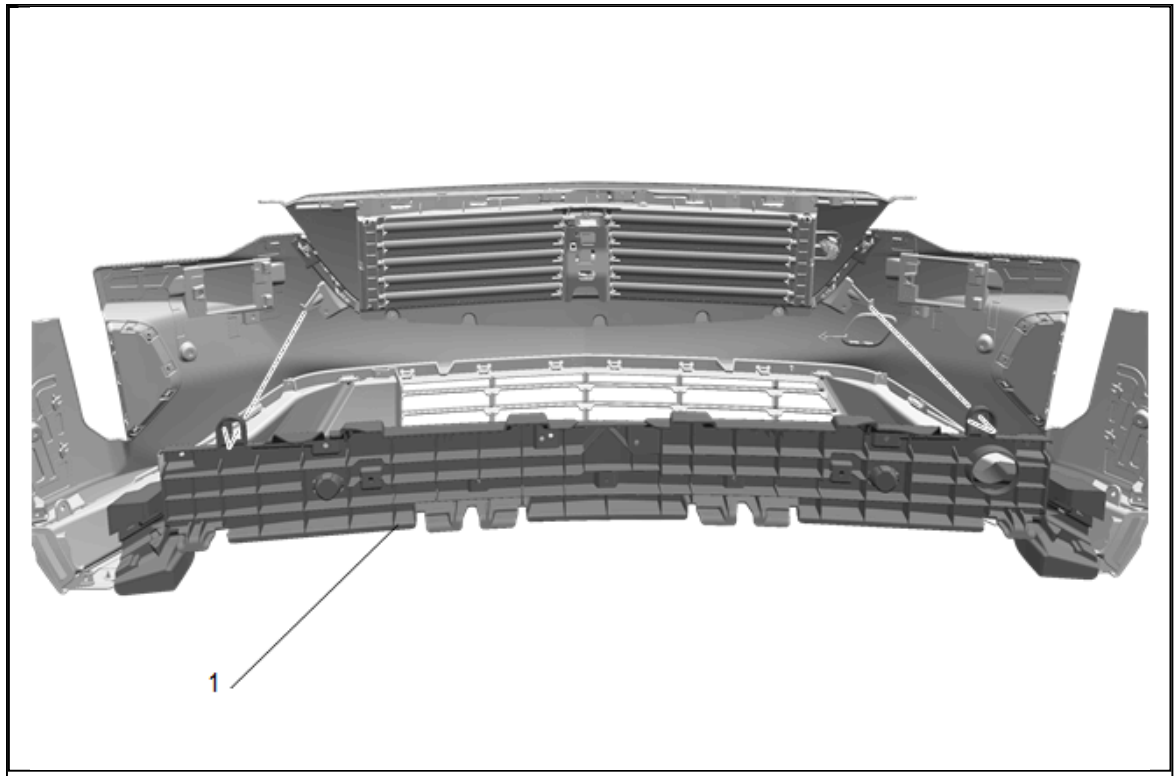

3.4. Front Bumper Fascia Energy Absorber (1) » Install

3.5. Position the wiring harness.

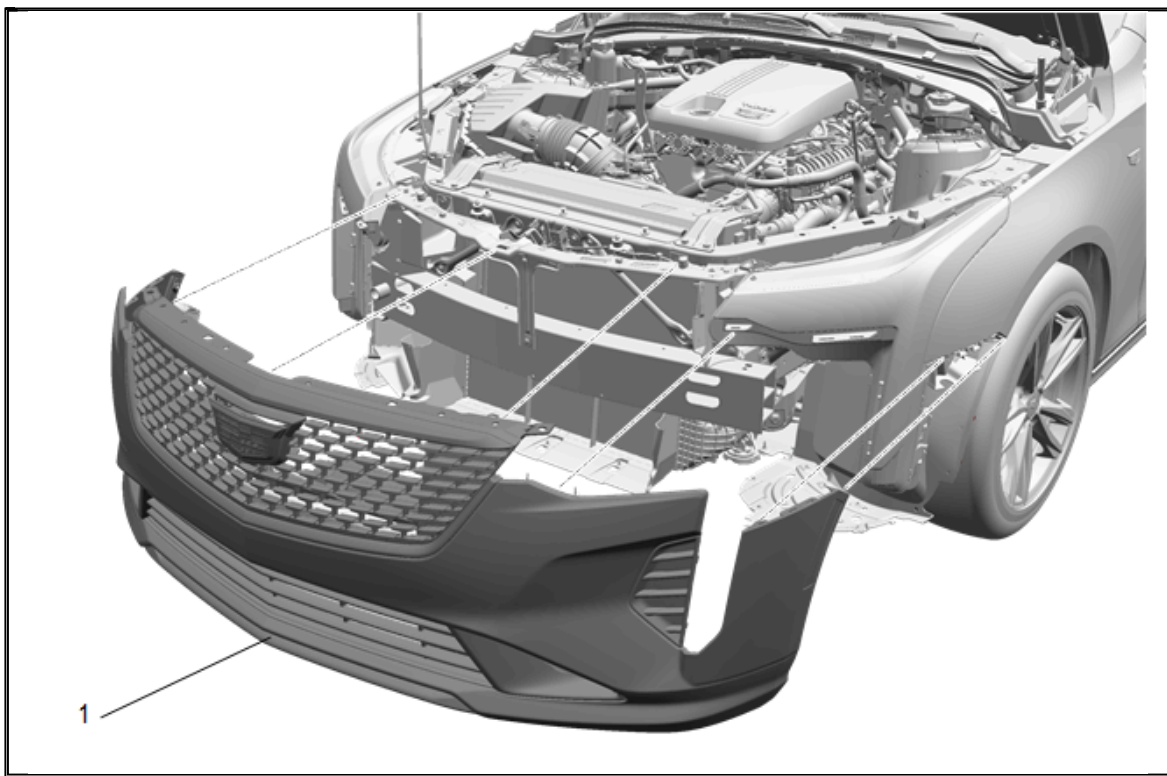

**Note:** The front bumper fascia will rest in place by guides on the center support upper structure.

4. With the aid of an assistant install the fascia.(1)

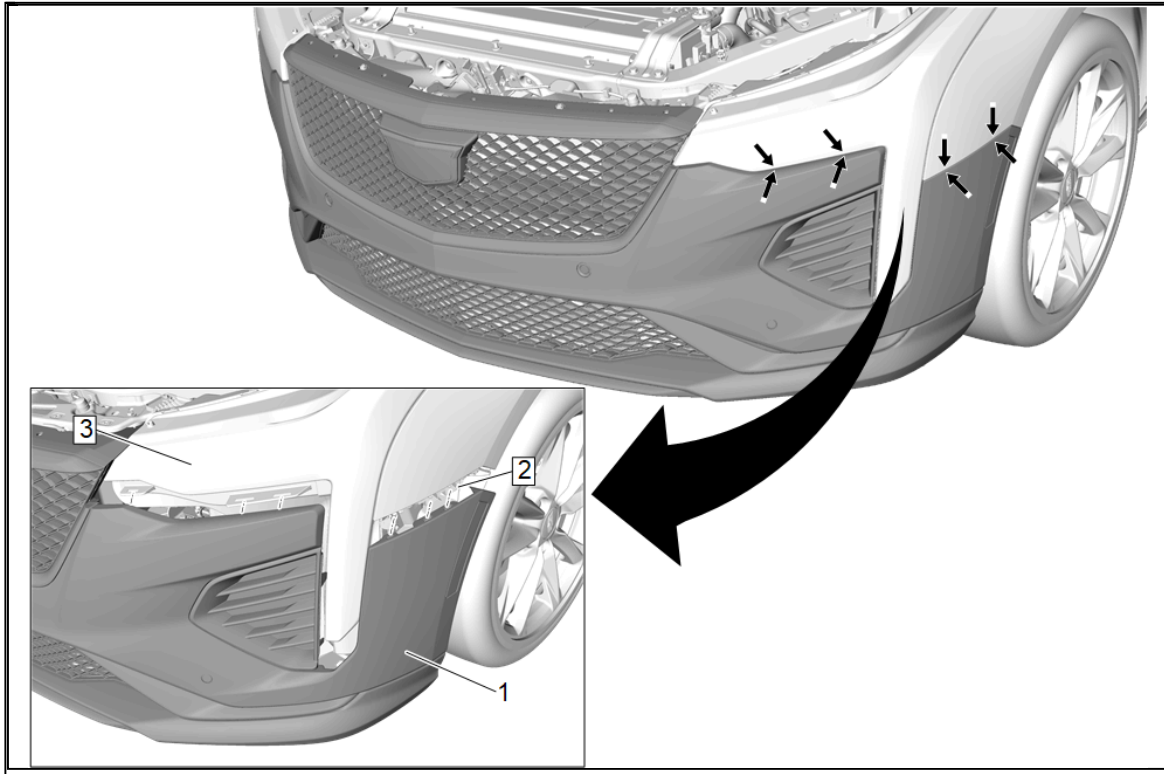

5. Install the left side of the front bumper fascia (1) to the front bumper fascia guide (2) and the front headlamp (3).

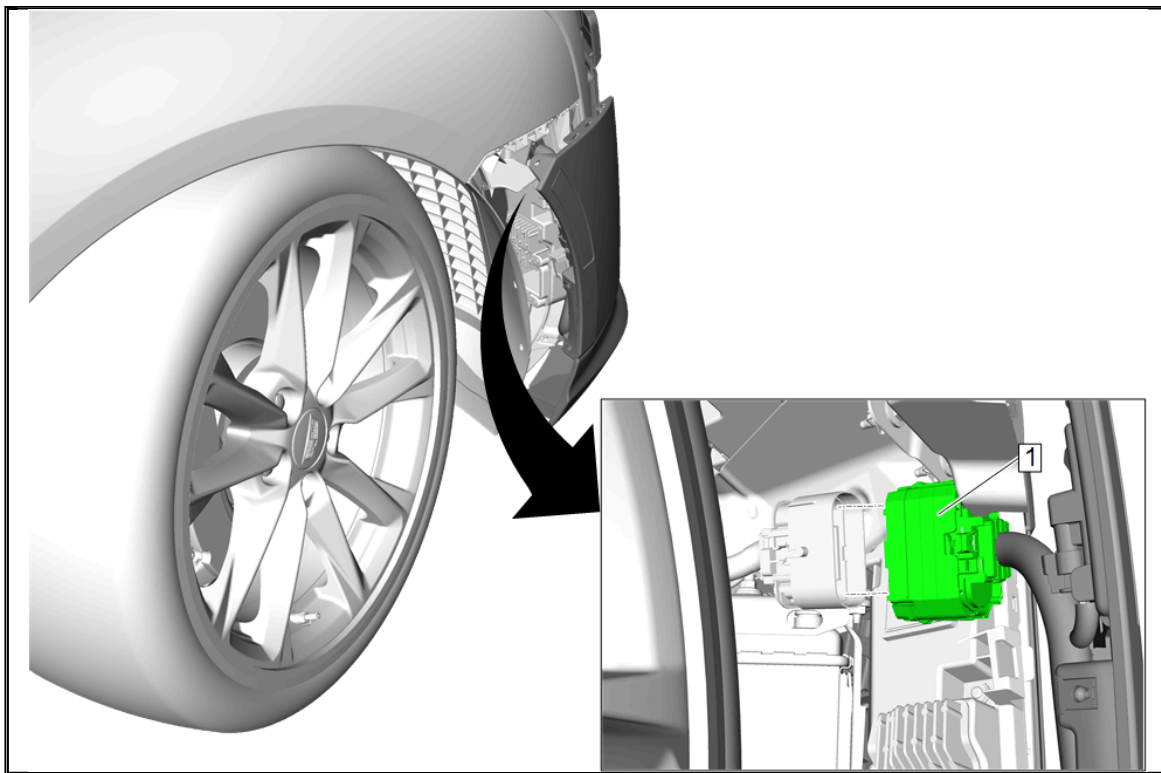

6. Reposition the front bumper fascia on the right side to gain access to the electrical connector (1).
7. Connect the electrical connector.

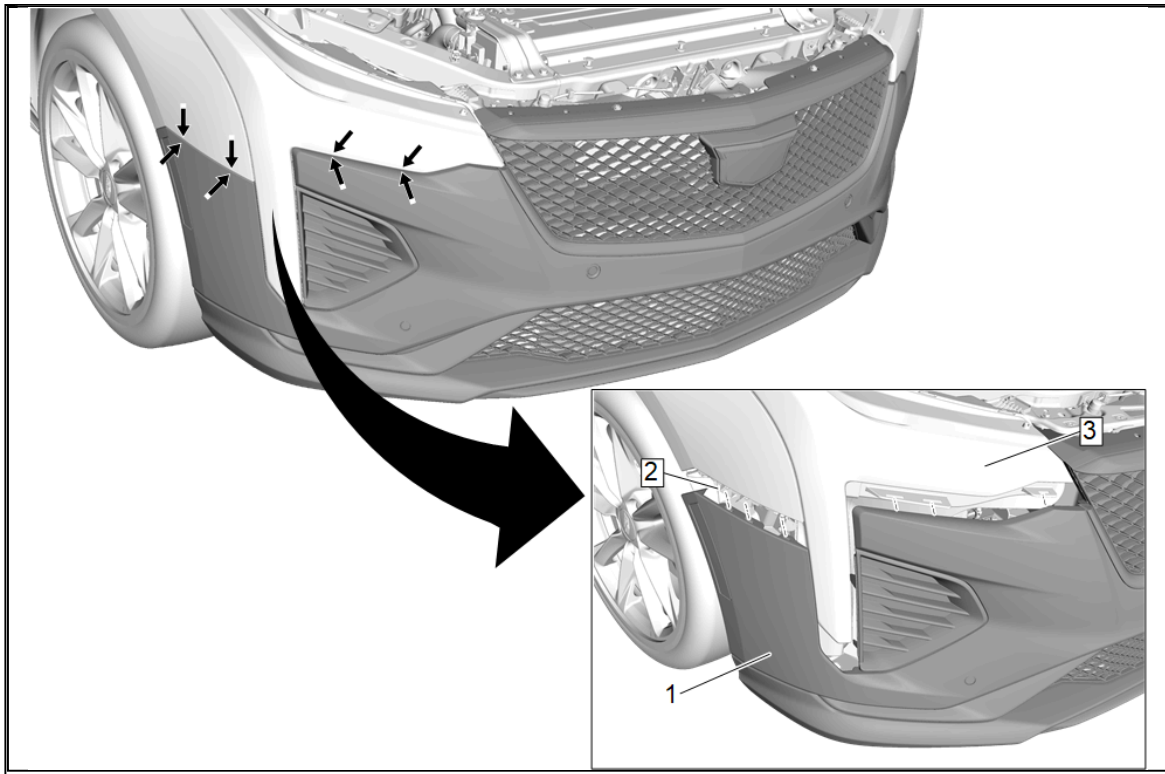

8. Install the right side of the front bumper fascia (1) to the front bumper fascia guide (2) and the front headlamp (3).

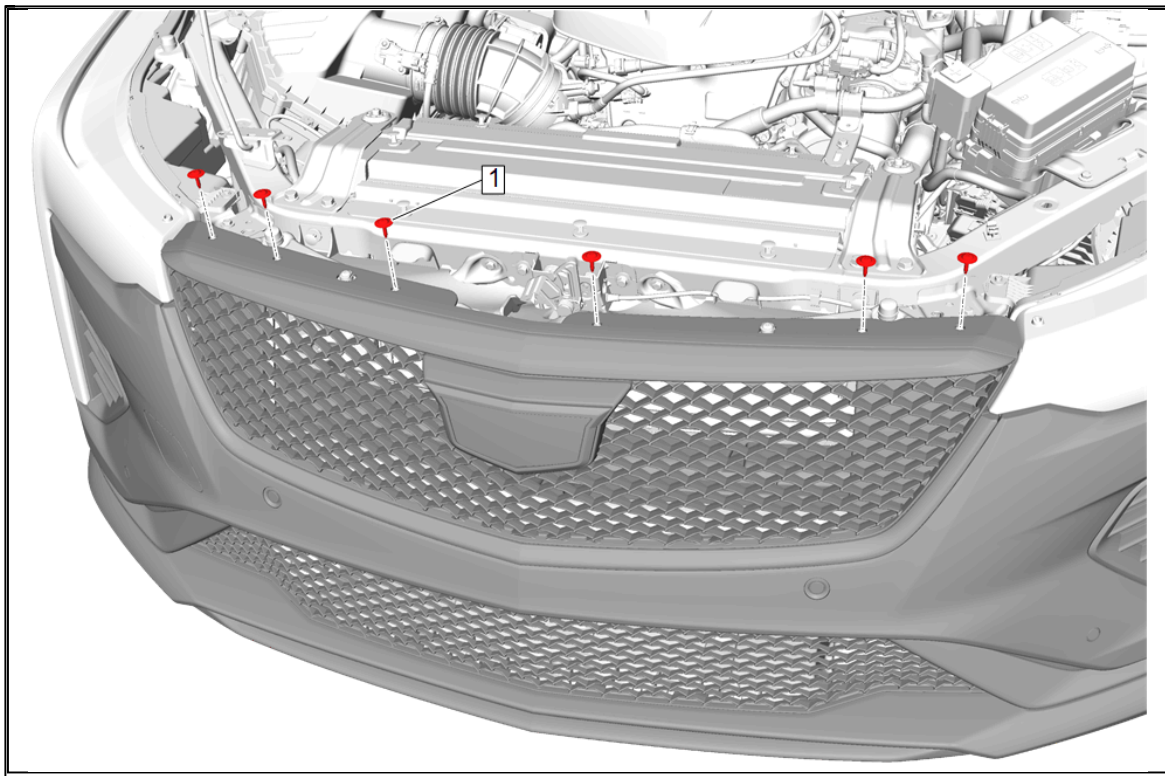

9. Front Bumper Fascia Bolt (1) » Install and tighten [6x] — Tighten bolts to 2.5 N.m (22 lb in).

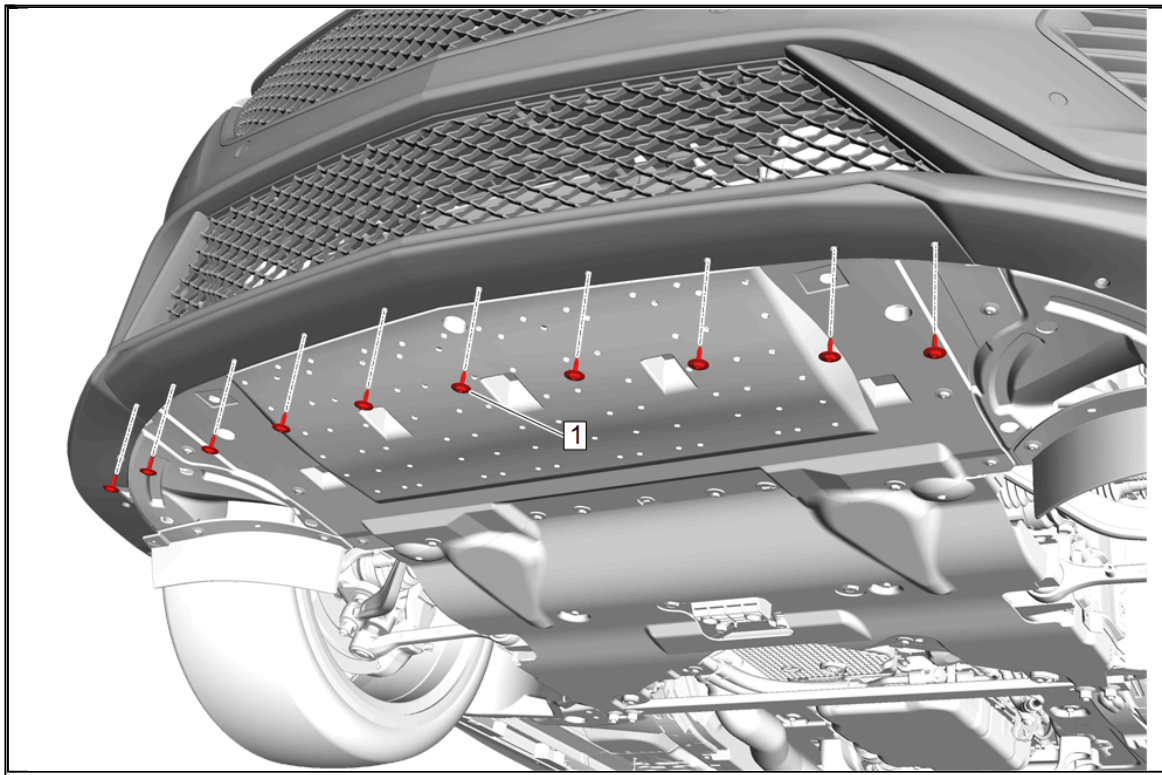

10. Front Bumper Fascia Center Air Deflector Screw (1) » Install and tighten [10x] — Tighten screws to 2.5 N.m (22 lb in).

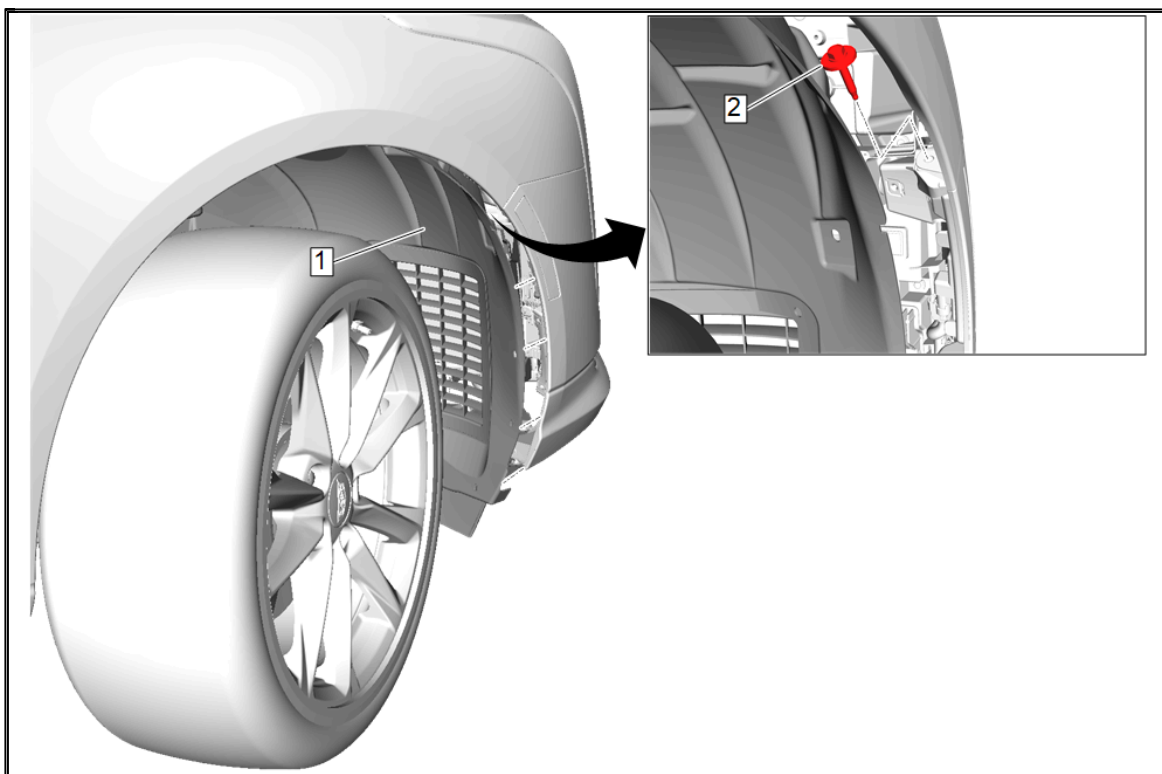

11. Reposition the right front wheelhouse liner (1) to install the right side upper front bumper fascia bolt (2).
12. Install and tighten the right side upper front bumper fascia bolt (2). Tighten bolt to 2.5 N.m (22 lb in).

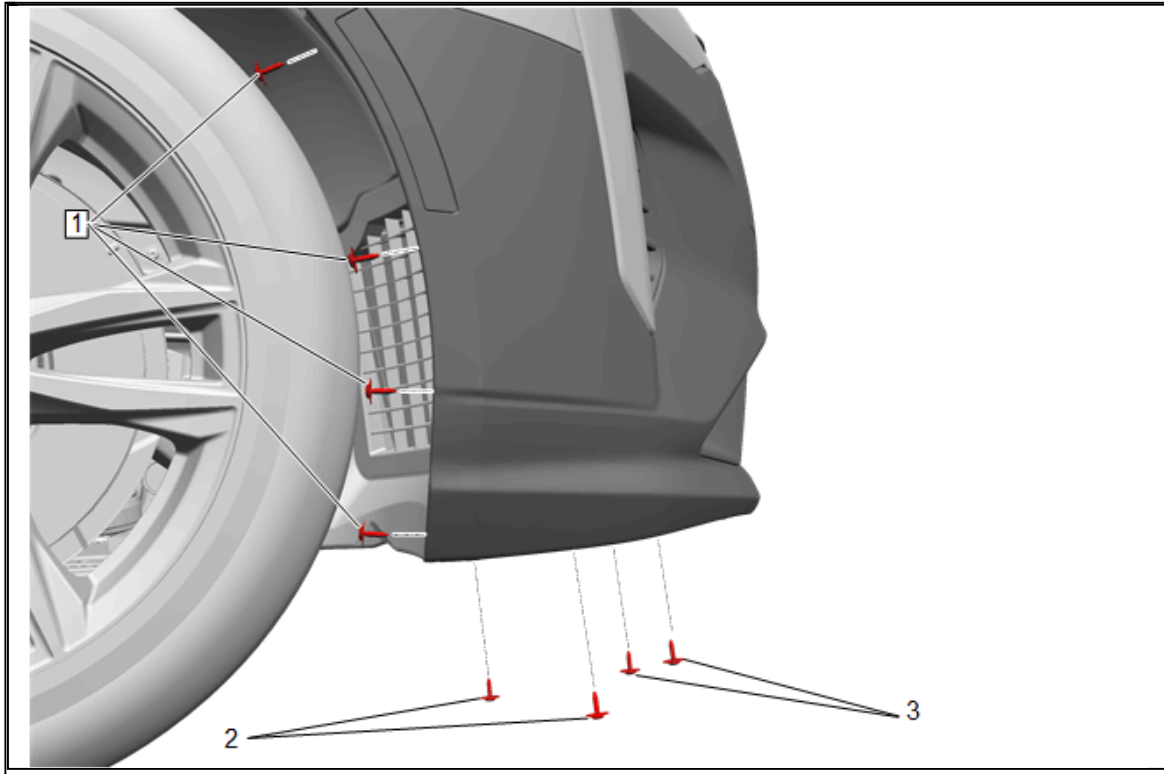

13. Front Bumper Fascia Bolt - Right Side (3) » Install and tighten [2x] — Tighten bolts to 2.5 N.m (22 lb in).
14. Front Tire Front Air Deflector Bolt - Right Side (2) » Install and tighten [2x] — Tighten bolts to 2.5 N.m (22 lb in).
15. Front Wheelhouse Liner Bolt - Right Side (1) » Install and tighten [4x] — Tighten bolts to 2.5 N.m (22 lb in).

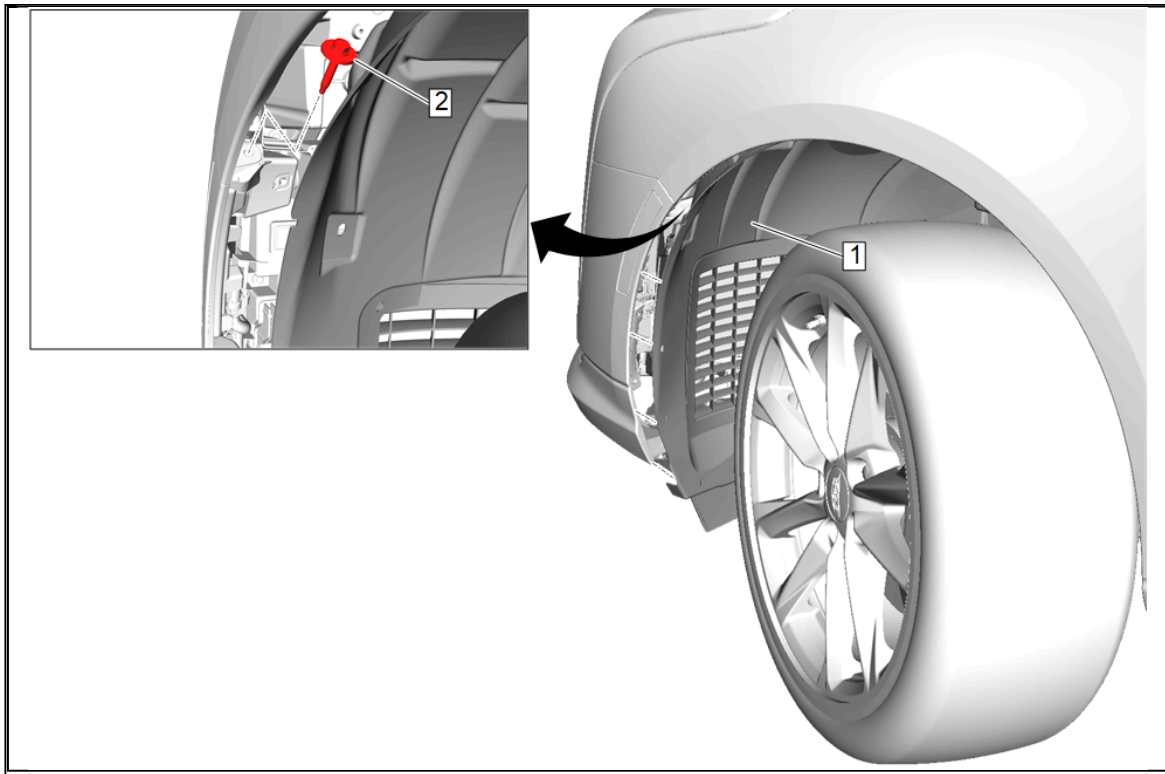

16. Reposition the left front wheelhouse liner (1) to install the left side upper front bumper fascia bolt (2).
17. Install and tighten the left side upper front bumper fascia bolt (2). Tighten bolt to 2.5 N.m (22 lb in).

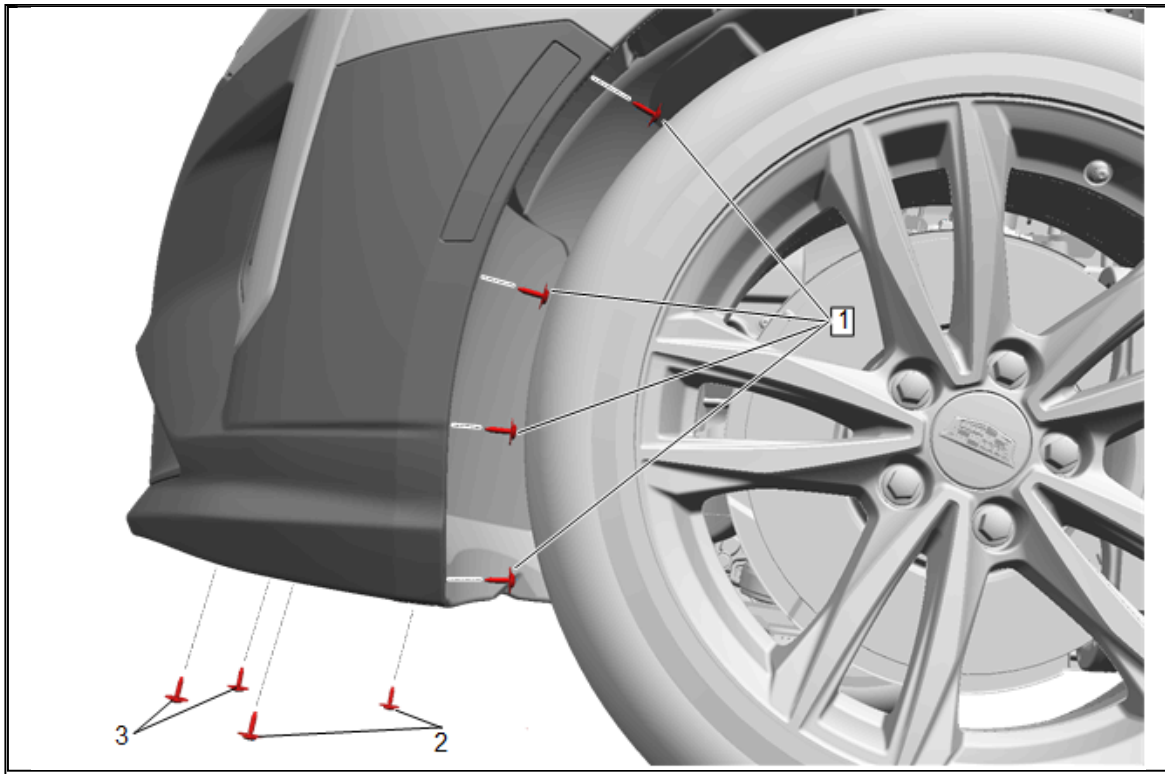

18. Front Bumper Fascia Bolt - Left Side (3) » Install and tighten [2x] — Tighten bolts to 2.5 N.m (22 lb in).
19. Front Tire Front Air Deflector Bolt - Left Side (2) » Install and tighten [2x] — Tighten bolts to 2.5 N.m (22 lb in).
20. Front Wheelhouse Liner Bolt - Left Side (1) » Install and tighten [4x] — Tighten bolts to 2.5 N.m (22 lb in).
21. Remove the support and lower the vehicle.
22. Ensure all electrical connections are intact, test any front lighting to confirm it is functioning.

### **Remove Rear Emblem**

1. Turn off vehicle.



**Caution:** Applying excessive heat to the emblem/nameplate may damage the paint and surrounding panel surfaces during removal. Heat temperature SHOULD NOT exceed 79°C (175°F).

2. Use a small flat-bladed tool to pull and release the rear compartment lid latch cover (1).
3. Rear Compartment Lid Latch Cover (1) » Remove

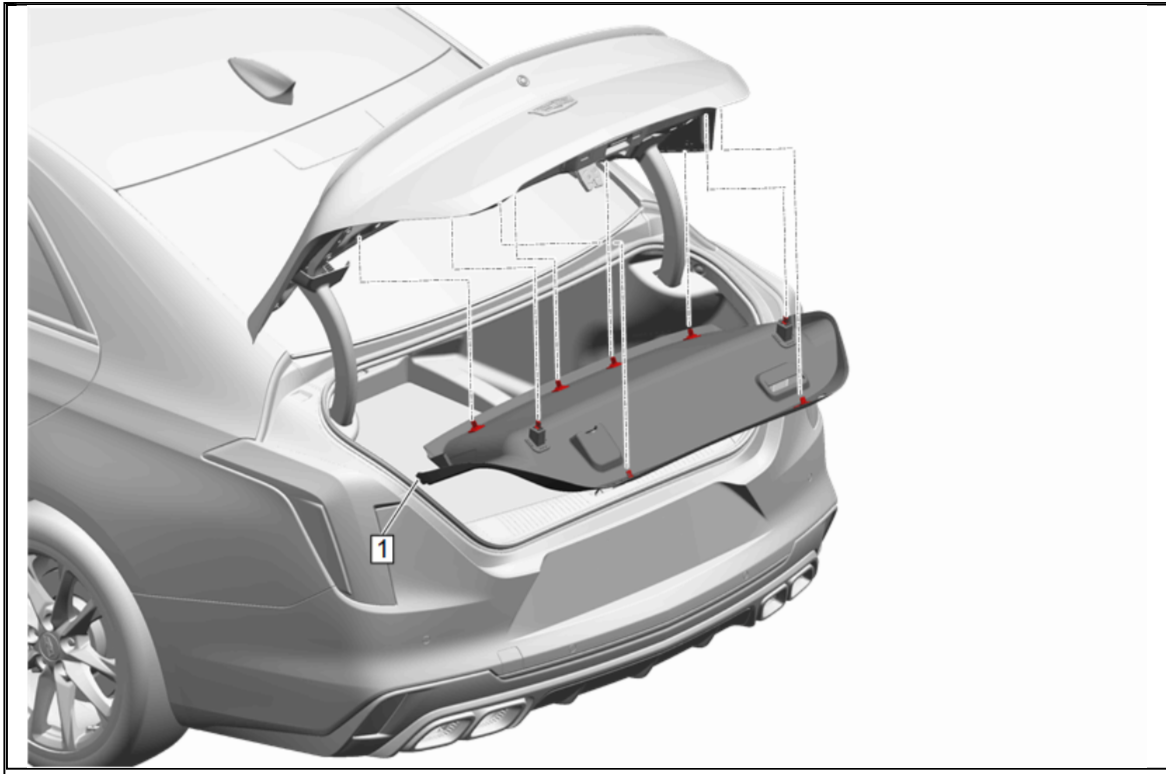

4. Use a flat-bladed plastic tool to disengage the push-in retainers from the sheet metal.
5. Rear Compartment Lid Inner Panel Trim (1) » Remove

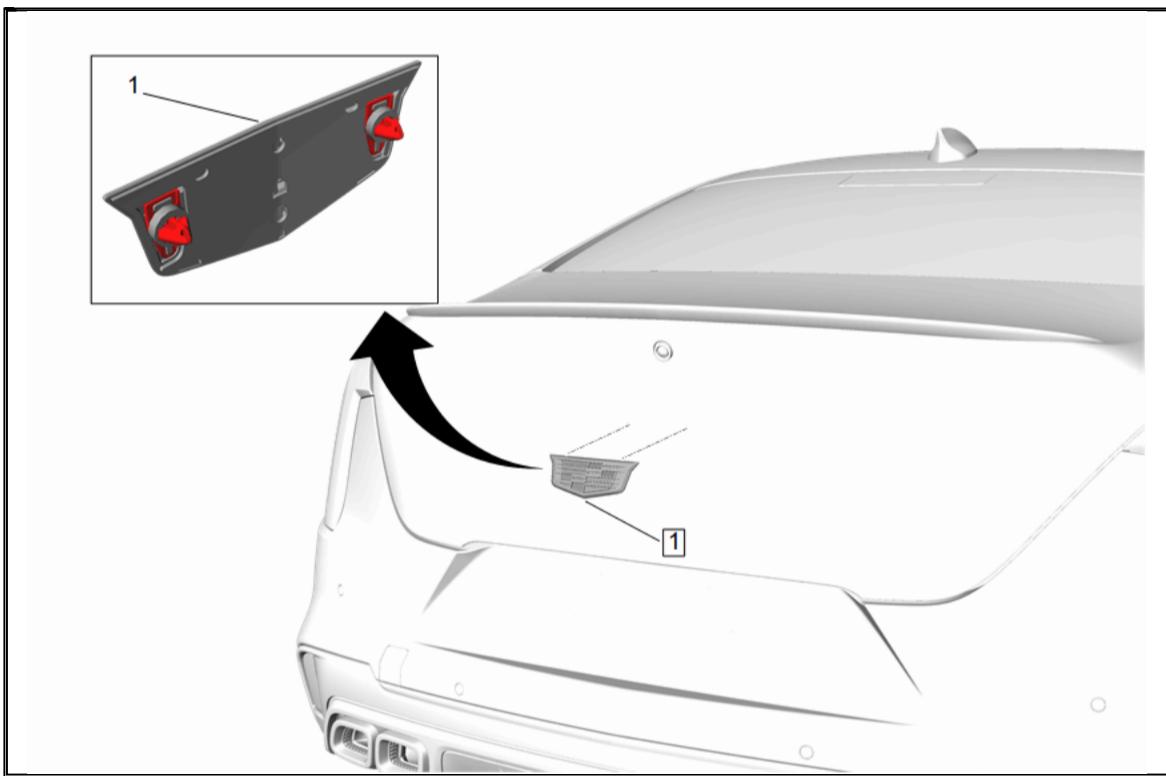

**Note:** Use caution during the steps to avoid marring or scratching the class "A" paint finish.

6. Apply two layers of masking tape around the rear compartment lid emblem/nameplate (1) to prevent paint damage.
7. Warm the rear compartment lid emblem/nameplate (1) using a hair dryer or heat gun not exceeding 79°C (175°F). Care should be given to protect the interfacing surface.
8. From inside the rear compartment lid, squeeze the retainer tabs together while gently prying the rear compartment lid emblem/nameplate (1) off the vehicle body using a suitable plastic trim tool.
9. Rear Compartment Lid Emblem/Nameplate (1) » Remove
10. Remove the masking tape.
11. Remove any remaining adhesive residue.
  - 11.1. Heavy foam/adhesive residue remaining on the painted surface can be removed using 3M's Scotch-Brite™ Molding Adhesive and Stripe Removal Disc (4 inch) or (6 inch). This disc will not damage the class "A" paint finish.
  - 11.2. Light adhesive residue remaining on the painted surface can be removed using 3M's General Purpose Adhesive Cleaner, or isopropyl alcohol, and a soft clean cloth.

### Install Rear Emblem

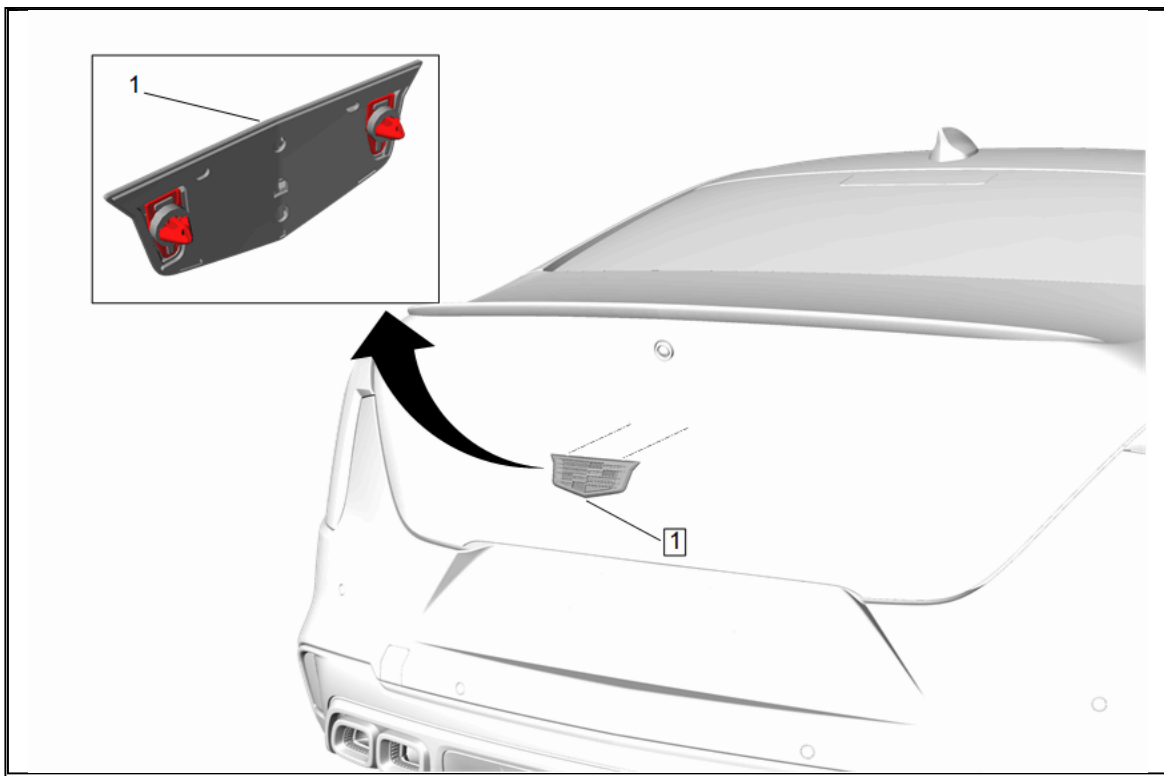

1. The painted surface must be clean and dry before installation of a new rear compartment lid emblem/nameplate (1).
  - 1.1. Temperature ranges required for installation of a new rear compartment lid emblem/nameplate (1) are 16°C (60°F) - 43°C (110°F) for the body and the emblem/nameplate.

1.2. General surface contaminants such as dirt, dust, fingerprints, moisture, oil, etc., can be removed with a dry cleaning cloth from 3M (Scotch Brite High Performance Cloth), or Contec (Thunderbolt Cloth).

2. Rear Compartment Lid Emblem/Nameplate (1) » Install

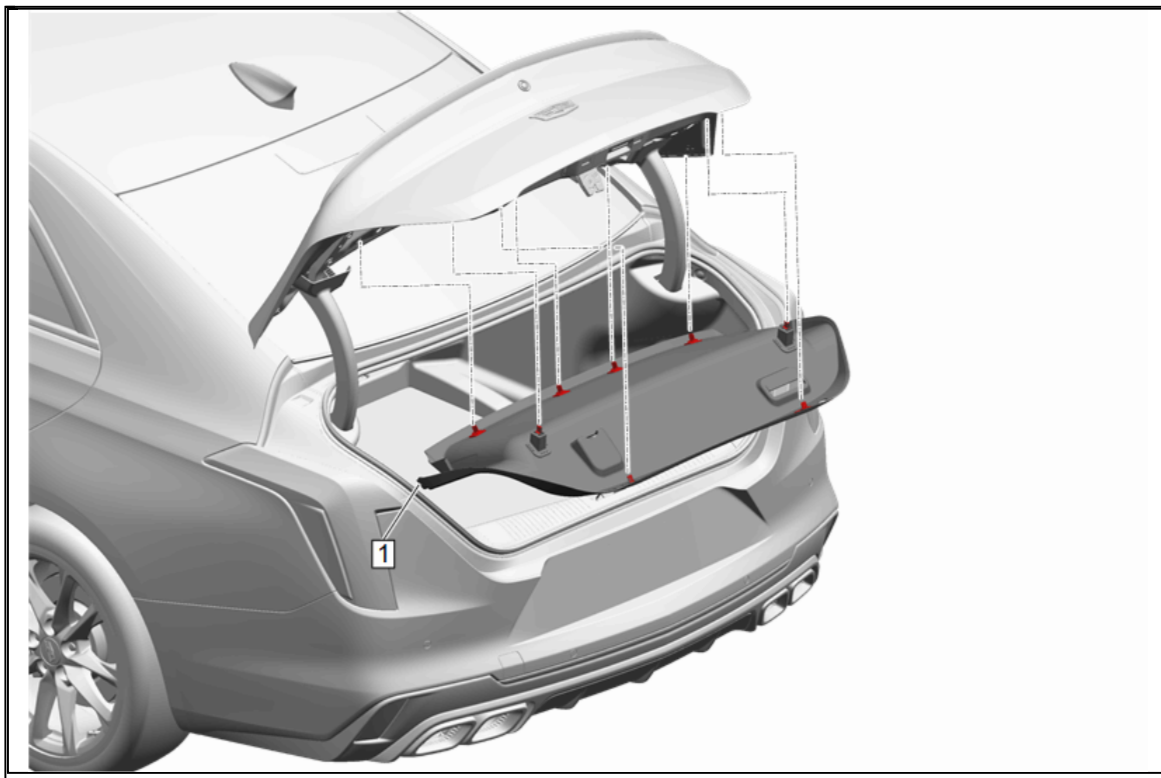

**Note:** Ensure the auxiliary rear compartment latch release handle is routed through the rear compartment lid inner panel trim.

3. Rear Compartment Lid Inner Panel Trim (1) » Install

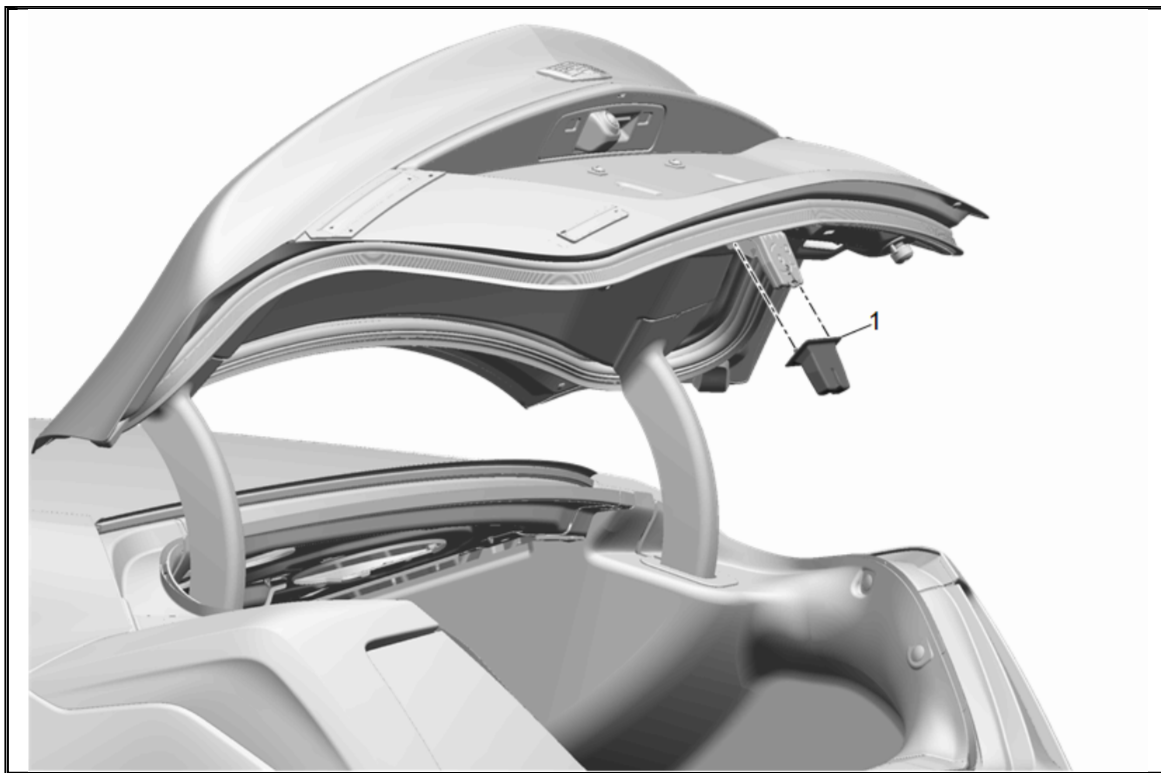

4. Rear Compartment Lid Latch Cover (1) » Install

## Cadillac CT5 | Document ID: 5549267

**Body Emblem Package Installation (Instruction ID: 84670236)****Installation Instructions Part Number**

84670236

**Kit Contents**

<b>Qty</b>	<b>Description</b>
1	Emblem Assembly – Front
1	Emblem Assembly – Rear Compartment Lid
1	Alcohol Wipe
1	Installation Instructions

**Tools Required**

Flat bladed plastic trim tool

Masking tape

**Procedure****Remove Front Emblem**

1. Read all instructions before performing procedure.
2. Inspect kit to verify all parts are included.
3. Turn off the vehicle.
4. Raise and support the vehicle. Refer to [Lifting and Jacking the Vehicle](#) in Vehicle Service Manual.
5. Open hood.
6. { If equipped } Disconnect the engine coolant heater wiring extension harness connector from the license plate bracket.

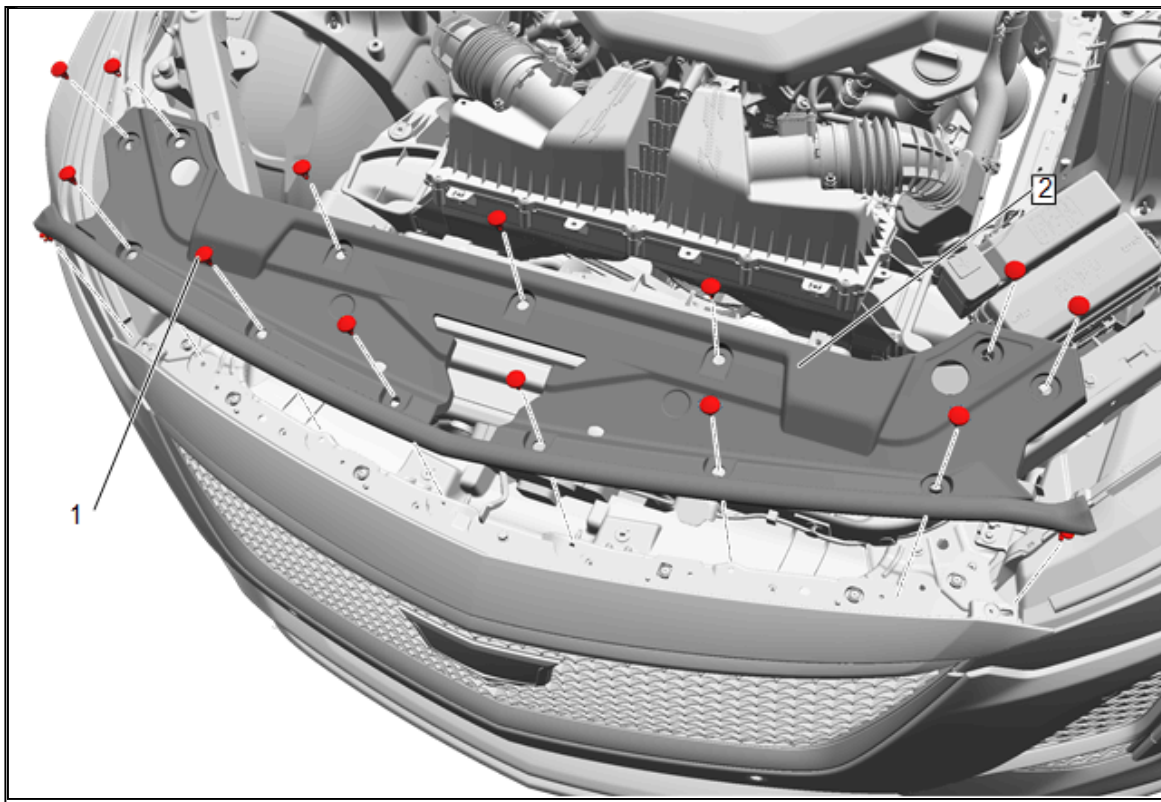

7. Remove the retainers (1) Qty: 15 from the front compartment front sight shield.
8. Remove the front compartment front sight shield (2).

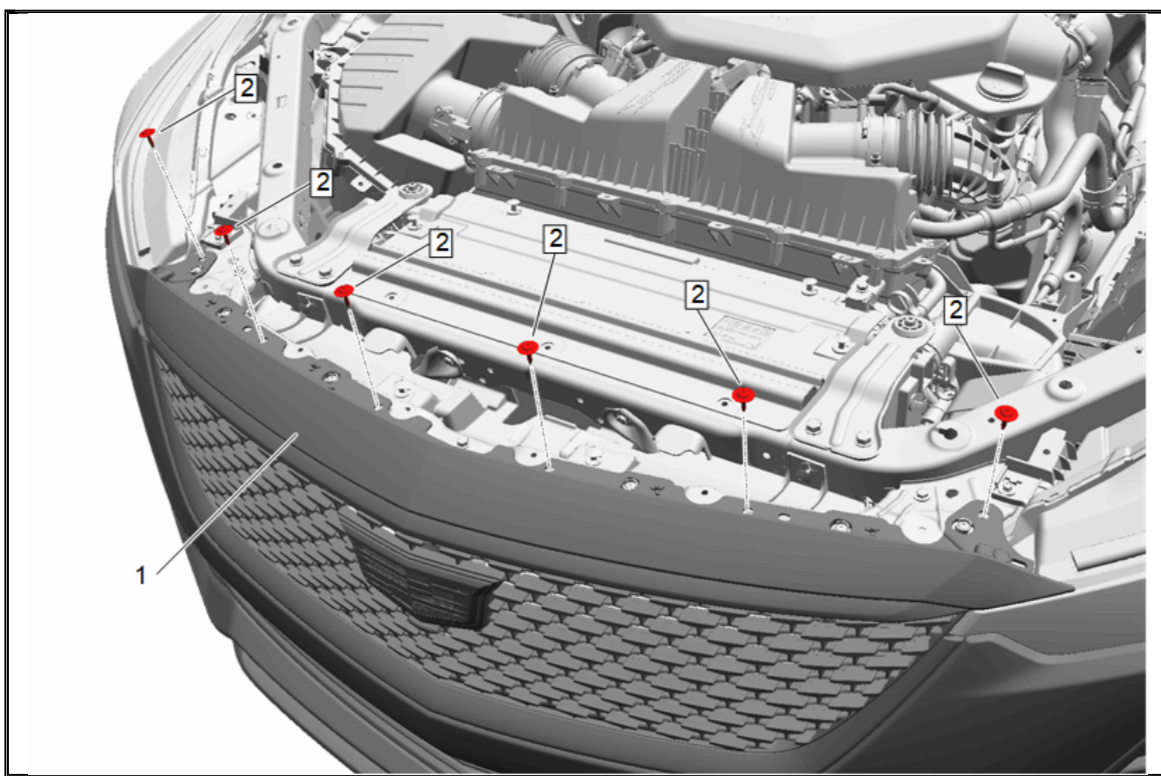

9. Remove the upper bolts (2) from the front bumper fascia (1).

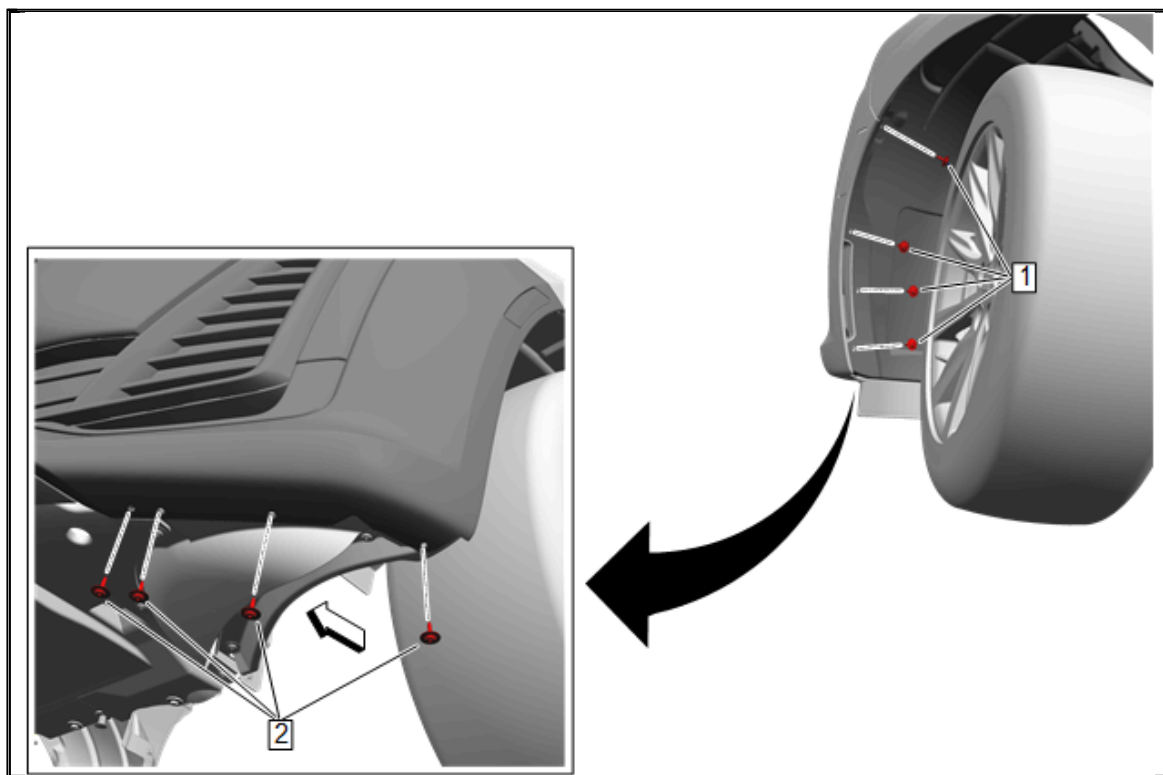

**Note:** Complete removal of wheel house liner is not required.

10. Remove the 4 left side front lower fascia bolts (2).
11. Remove the 4 left side wheelhouse liner bolts (1).

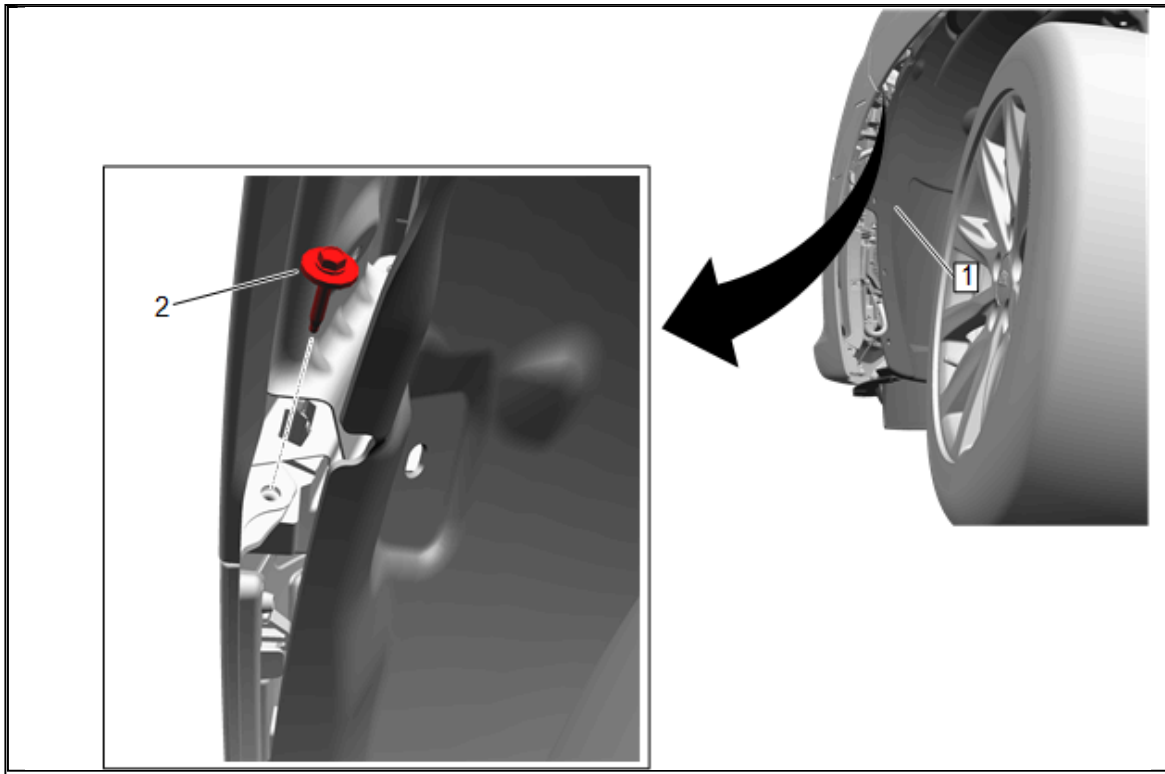

12. Reposition the left front wheelhouse liner (1) to gain access to the left side upper front bumper fascia bolt (2).
13. Remove the left side upper front bumper fascia bolt (2).

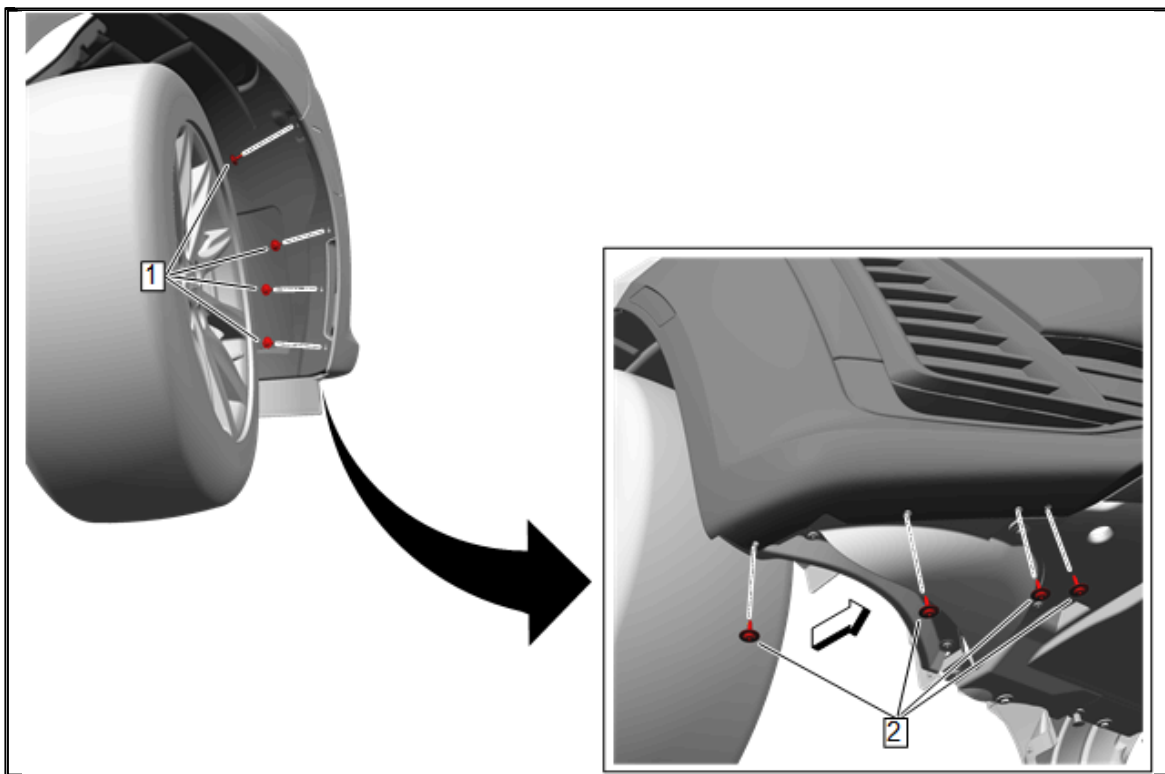

**Note:** Complete removal of wheel house liner is not required.

14. Remove the 4 right side front lower fascia bolts (2).
15. Remove the 4 right side wheelhouse liner bolts (1).

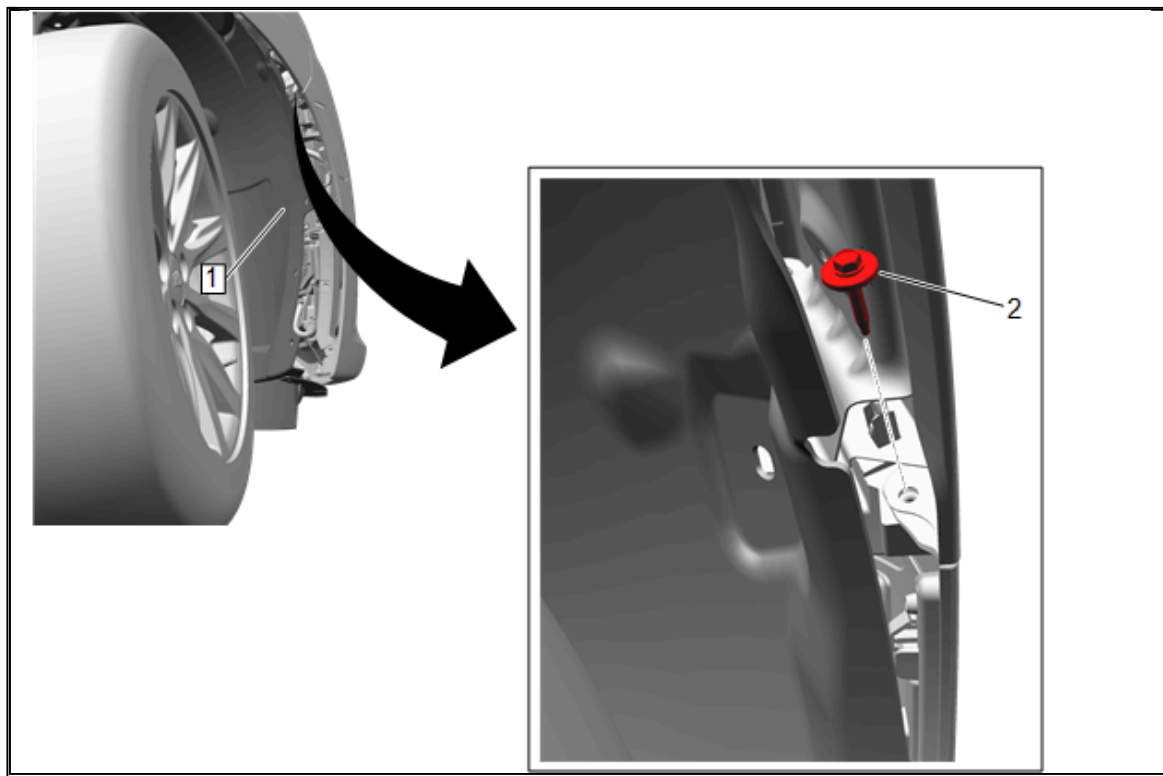

16. Reposition the right front wheelhouse liner (1) to gain access to the right side upper front bumper fascia bolt (2).
17. Remove the right side upper front bumper fascia bolt (2).

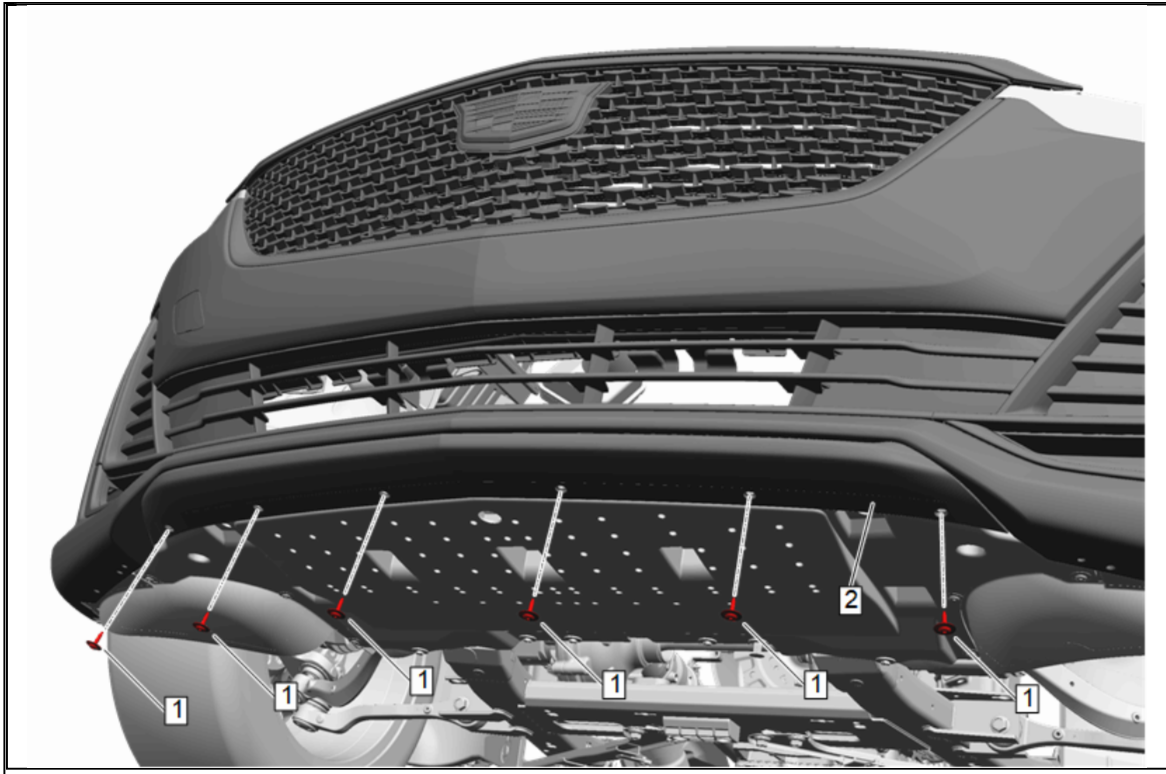

18. Remove the screws (1) from the front bumper fascia center air deflector (2).

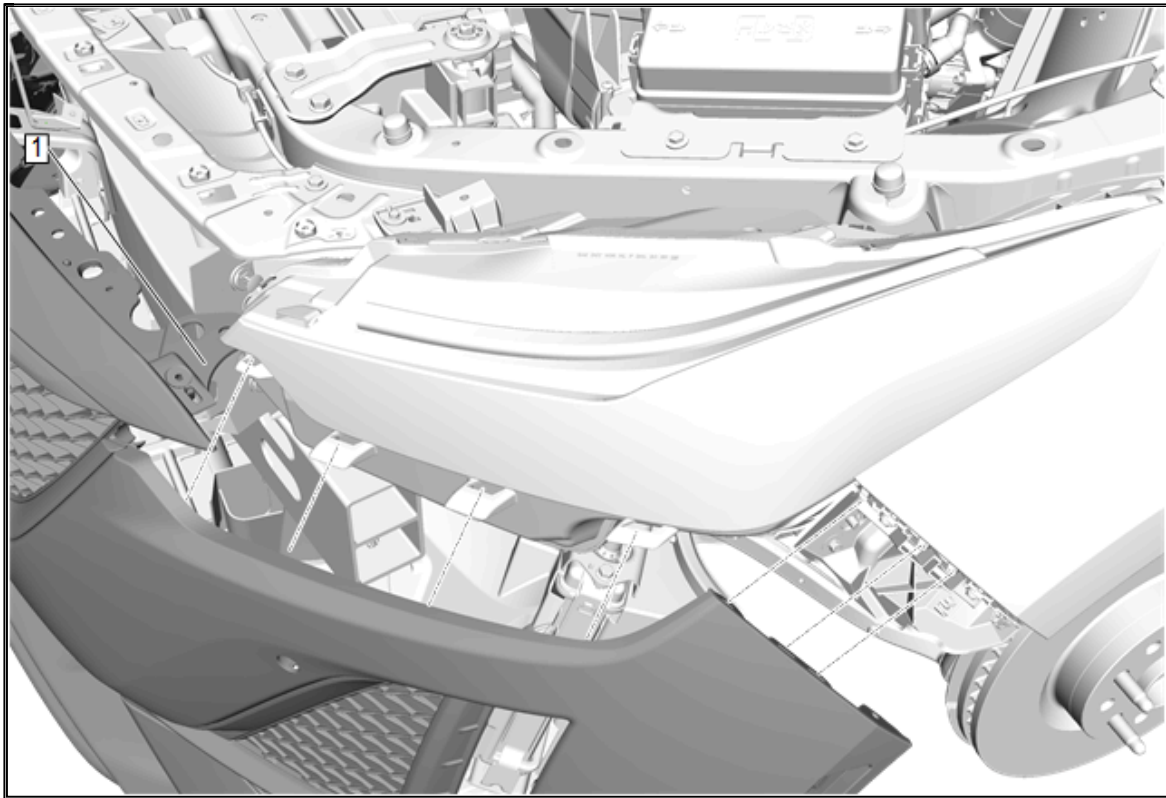

19. Carefully push a small nylon wedge between the fascia (1) and the fascia guide on both sides. Insert a small flat-bladed tool into the fascia slot and depress the snaps one at a time and pull on the fascia at the same time to gradually remove the fascia.
20. Release the tabs on the fascia (1) from the headlamp on both sides.

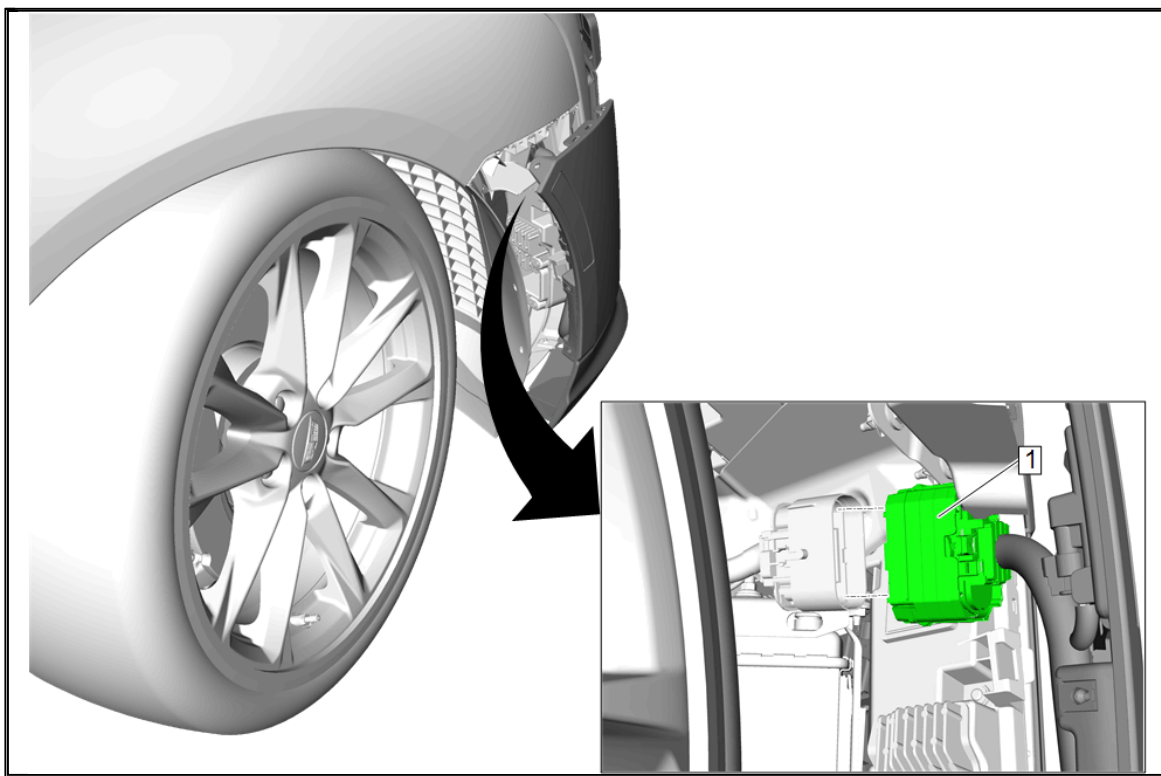

21. Reposition the front bumper fascia on the right side to gain access to the electrical connector (1).
22. Disconnect the electrical connector.

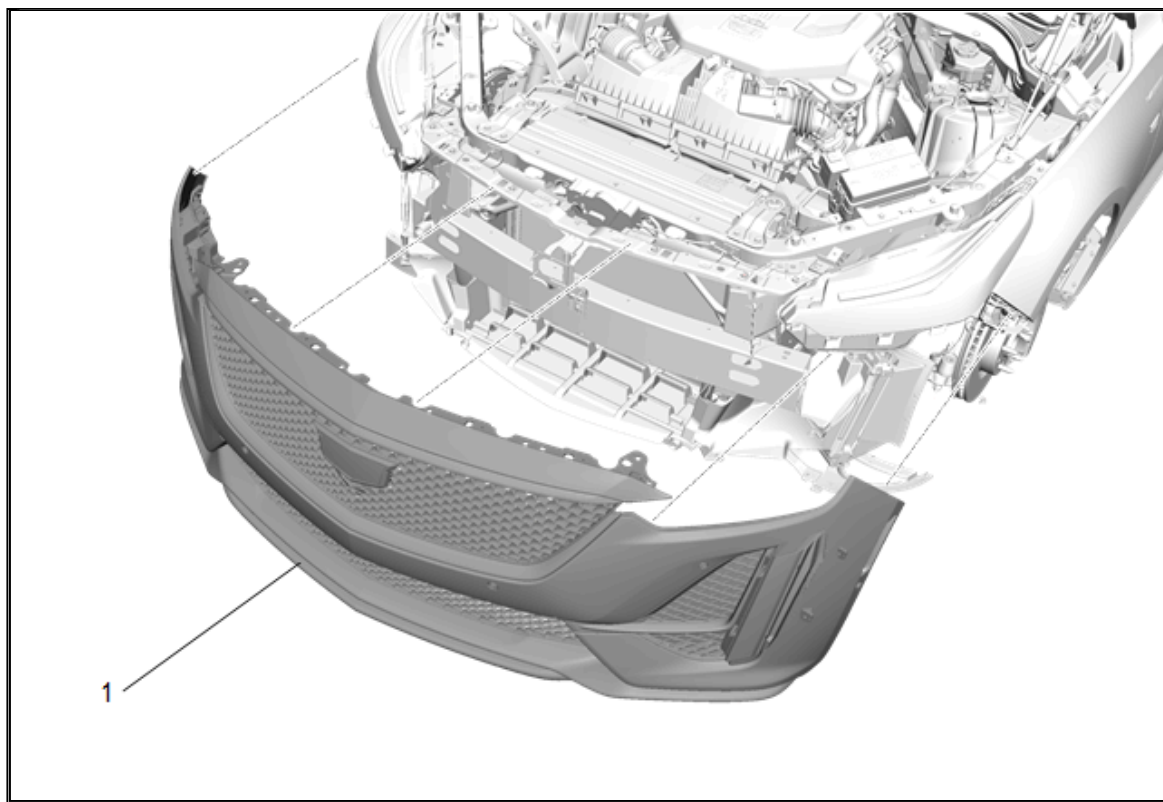

23. With the aid of an assistant, remove the fascia. (1)
24. Disconnect all electrical connectors.
25. Place the front bumper fascia on a clean suitable work surface to prevent damage.
- Note:** This step is only necessary if vehicle is equipped with front bumper shutter.
26. Reposition the front bumper fascia wiring harness.

### **Front Bumper Shutter**

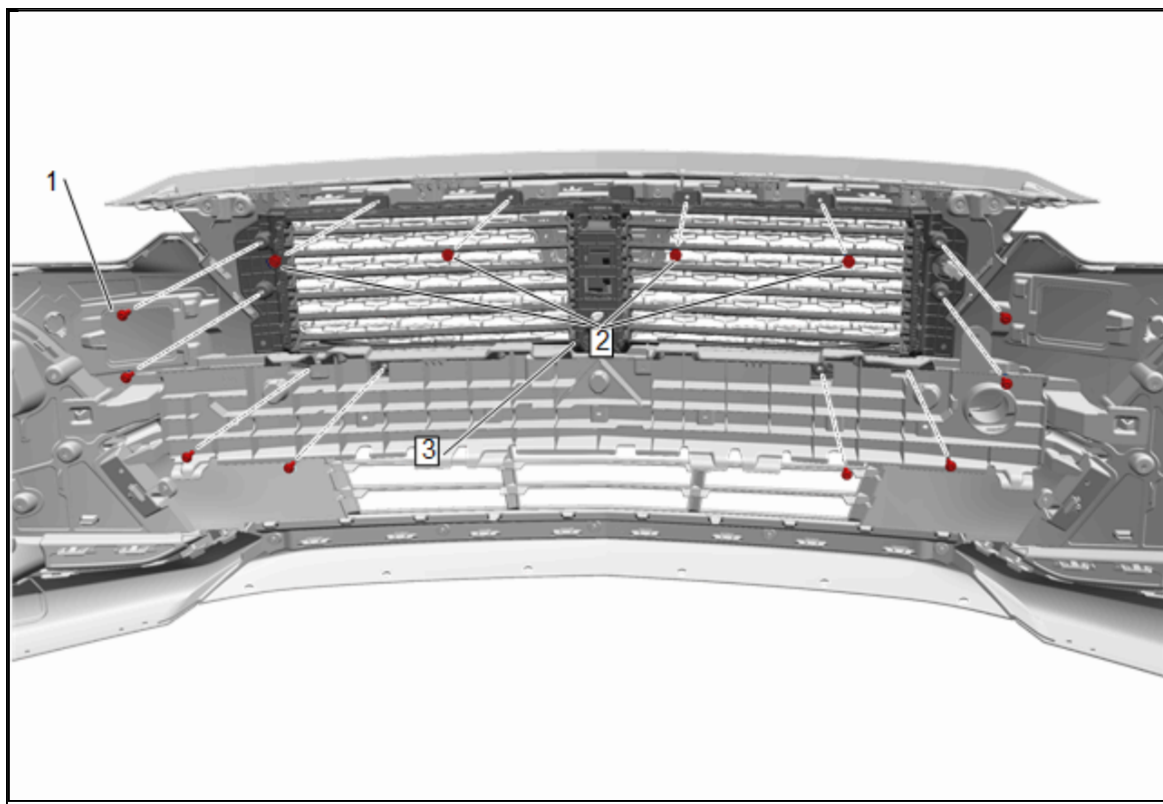

- 26.1. Remove the 8 bolts (1) from the front bumper shutter.
- 26.2. Remove the 4 upper bolts (2) from the front bumper shutter.
- 26.3. Pull the front bumper shutter frame (3) up and out from behind the front bumper fascia absorber.
- 26.4. Disconnect the electrical connector.

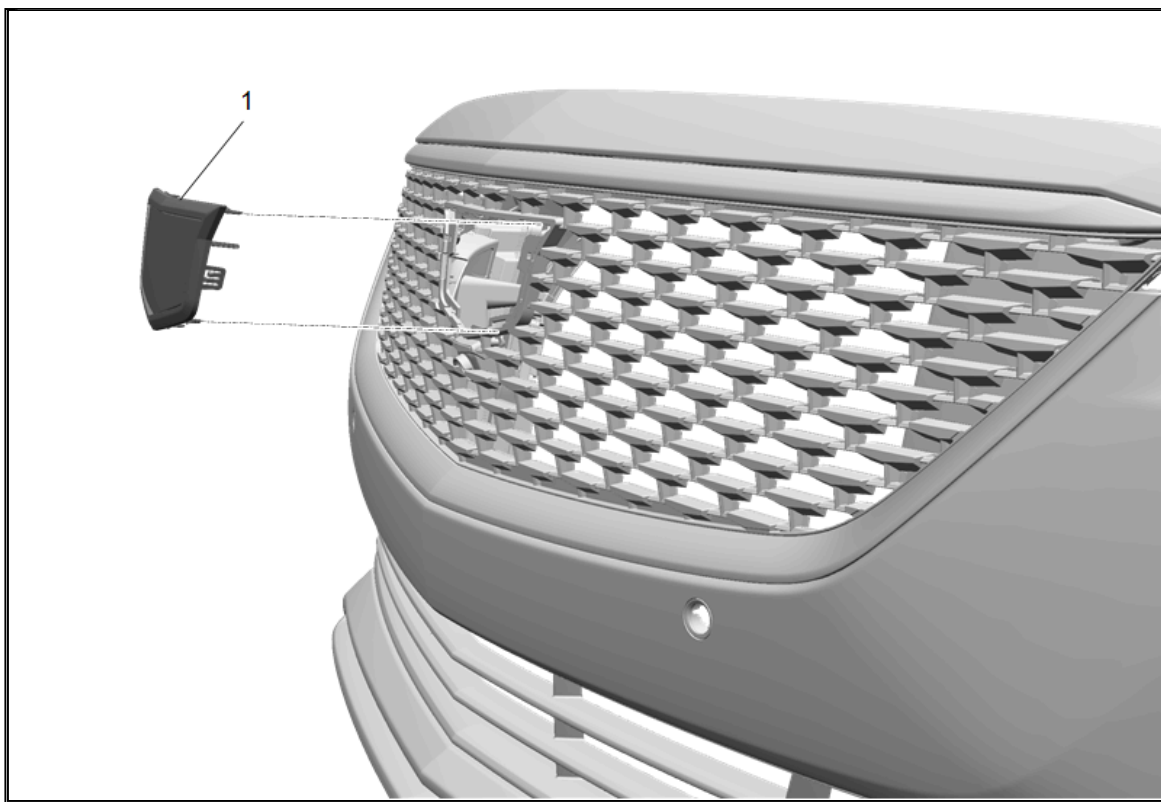

27. Using a suitable flat-bladed tool, release the locking tabs and remove the front grille emblem (1).

### **Install Front Emblem**

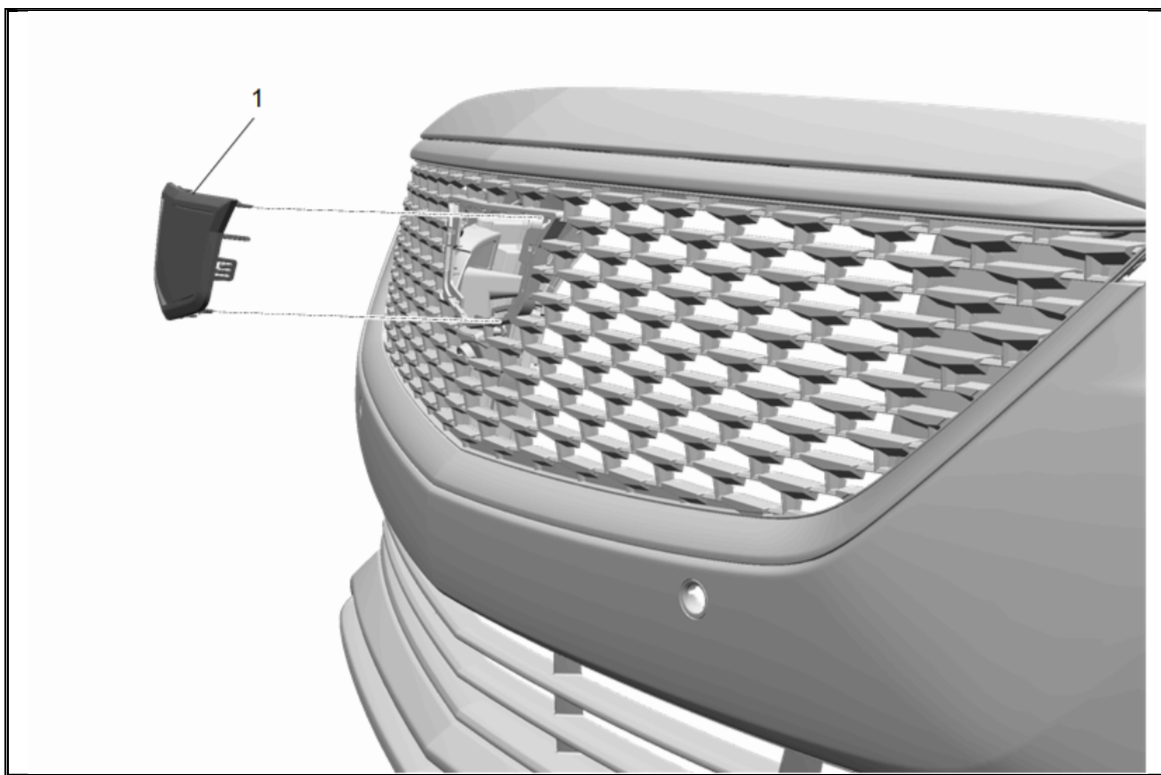

1. Accurately position the new front grille emblem (1) to the front grille and engaging the locking tabs.
2. Apply enough evenly distributed pressure to engage the locking/retention tabs.  
**Note:** This step is only necessary if vehicle is equipped with front bumper shutter.
3. Position the front bumper shutter frame to the front bumper fascia and connect the electrical connector.

### **Front Bumper Shutter**

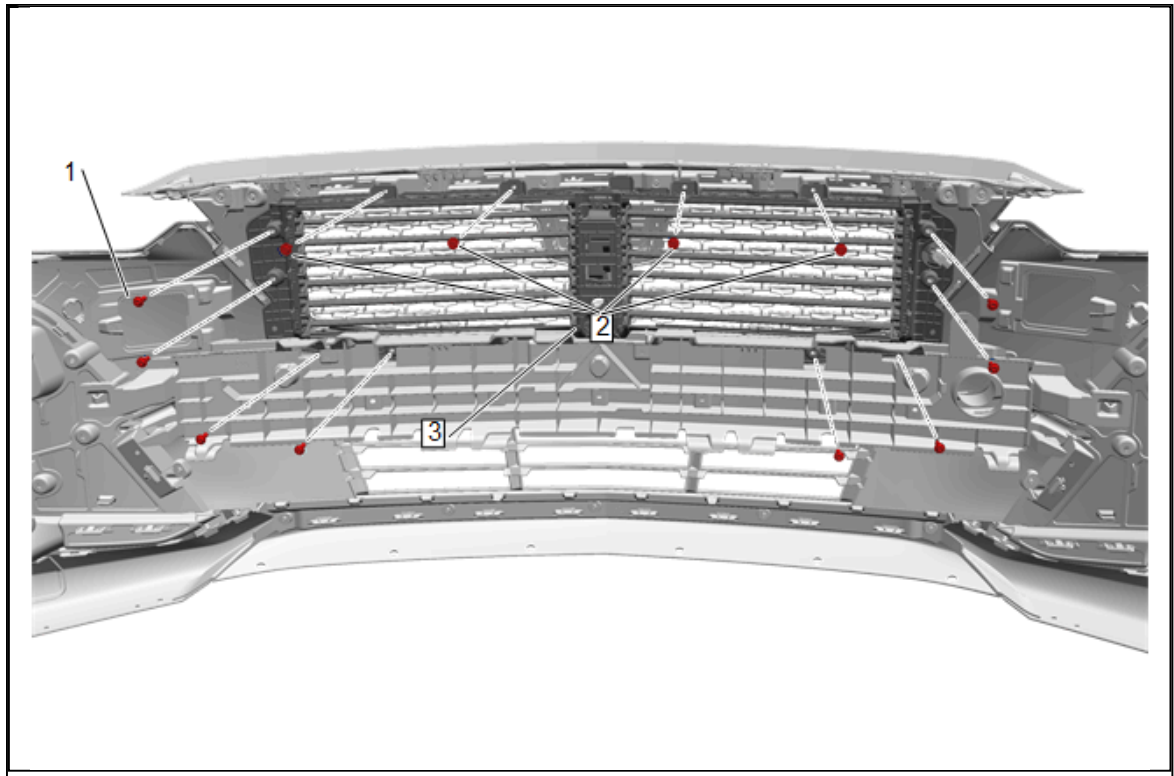

3.1. Install front bumper shutter frame (3) behind the front bumper fascia absorber.

**Caution:** Use the correct fastener in the correct location. Replacement fasteners must be the correct part number for that application. Fasteners requiring replacement or fasteners requiring the use of thread locking compound or sealant are identified in the service procedure. Do not use paints, lubricants, or corrosion inhibitors on fasteners or fastener joint surfaces unless specified. These coatings affect fastener torque and joint clamping force and may damage the fastener. Use the correct tightening sequence and specifications when installing fasteners in order to avoid damage to parts and systems.

3.2. Install the 4 upper bolts (2) to the front bumper shutter. Tighten the bolts to 2.5 N.m (22 lb in).

3.3. Install the 8 bolts (1) to the front bumper shutter. Tighten the bolts to 2.0 N.m (18 lb in).

3.4. Reposition the front bumper fascia wiring harness.

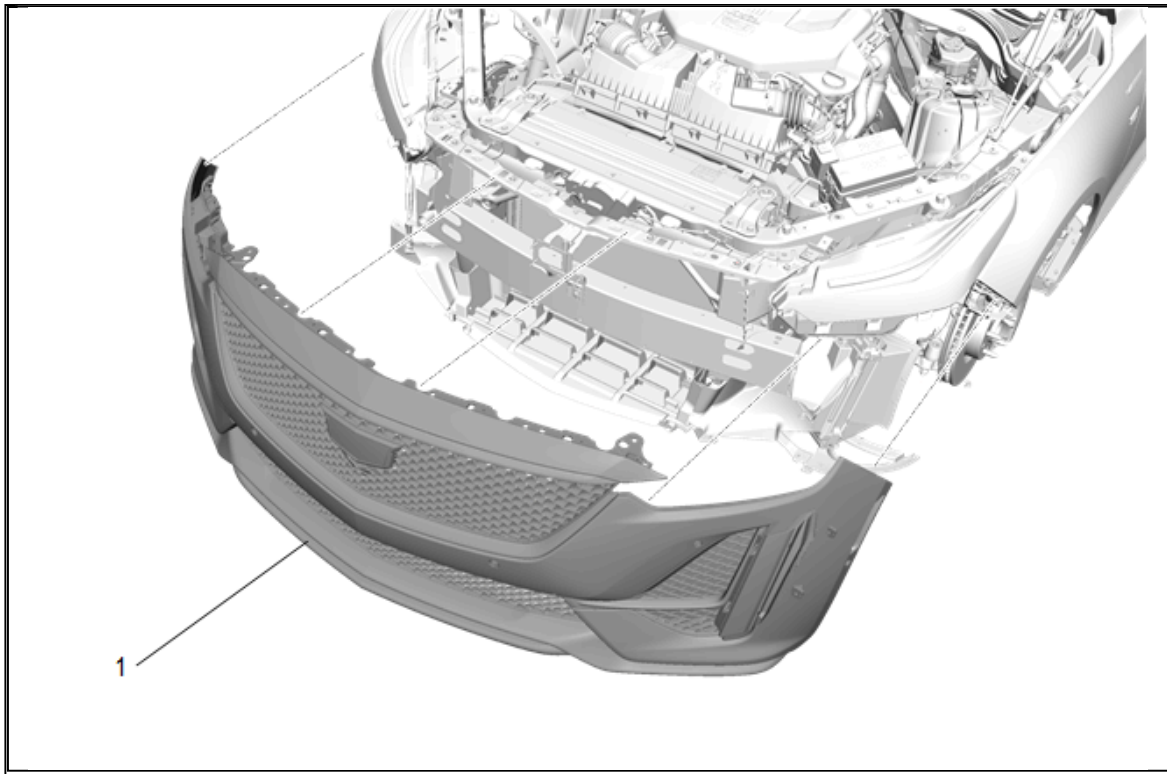

4. With the aid of an assistant, install the fascia. (1)
5. Connect the electrical connectors.

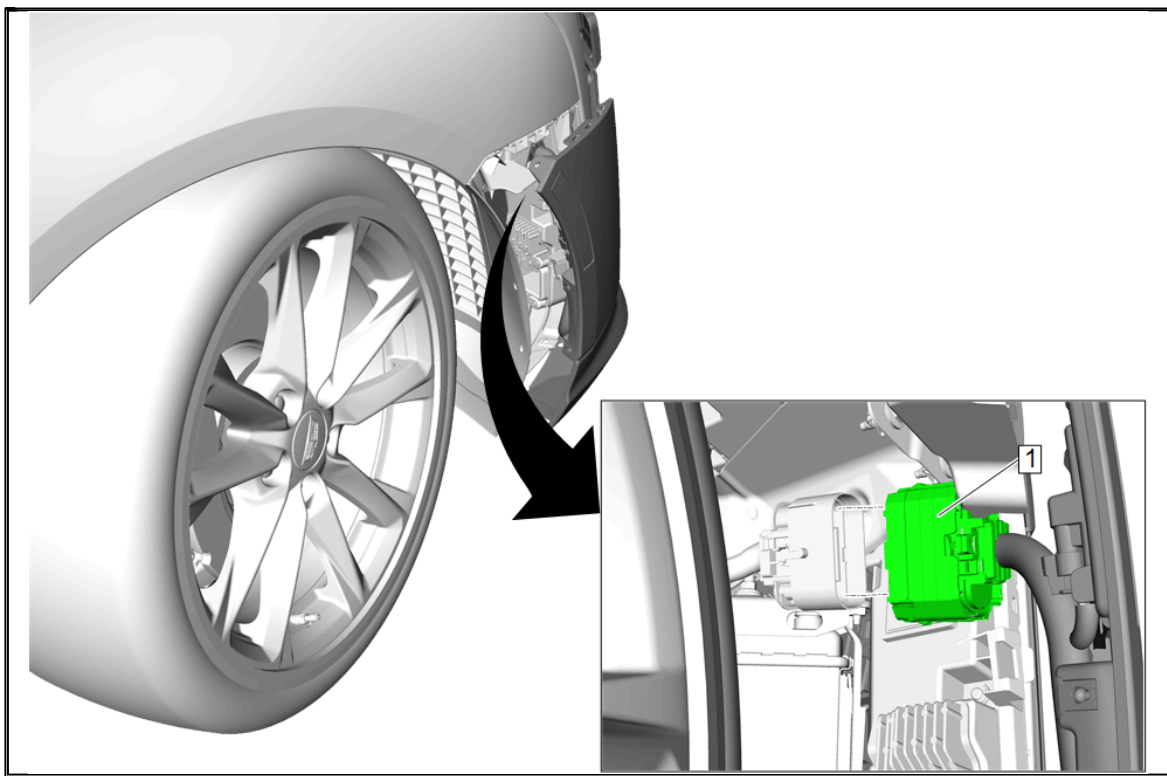

6. Reposition the front bumper fascia on the right side to gain access to the electrical connector (1).
7. Connect the electrical connector.

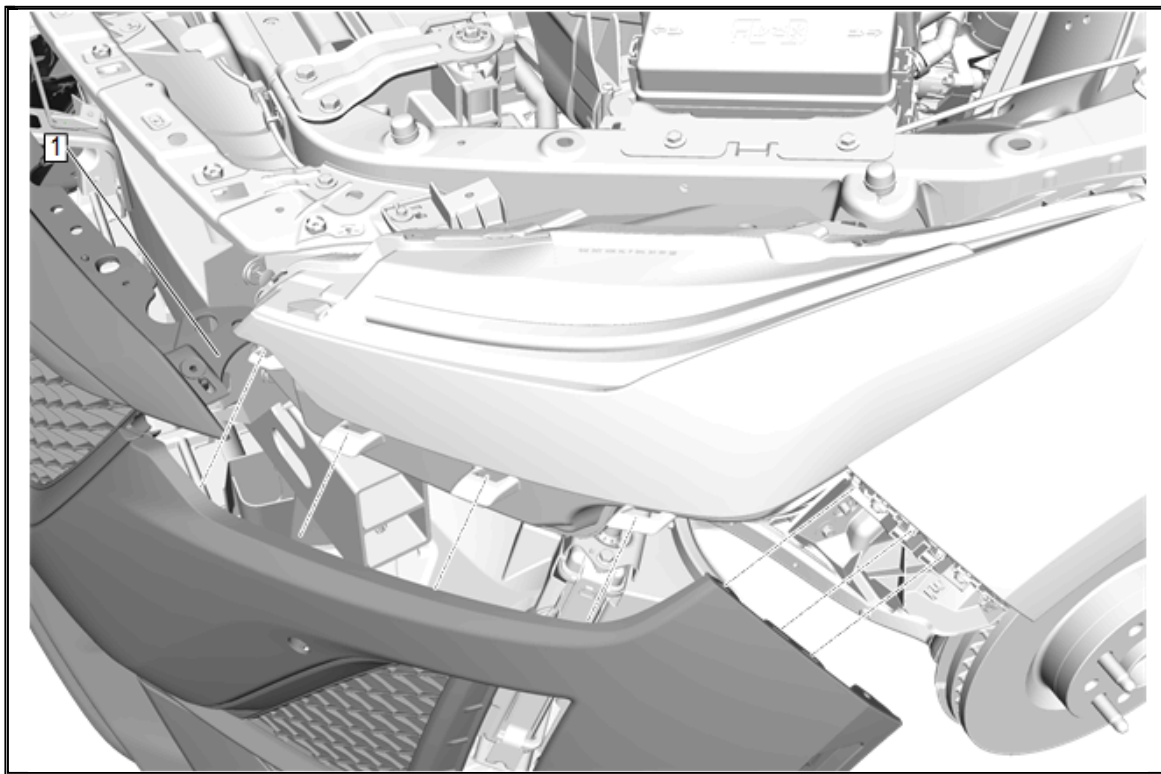

8. Install the front bumper fascia (1) to the headlamp and front bumper fascia guide on both sides.

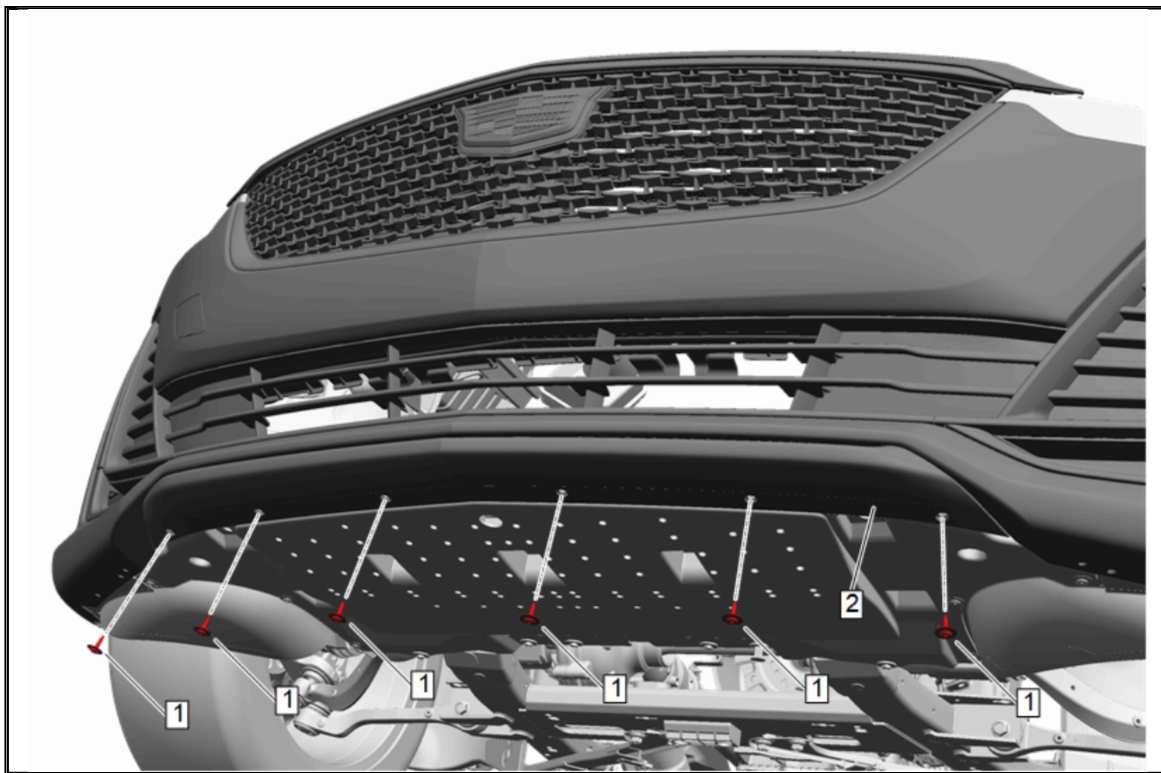

9. Install the screws (1) to the front bumper fascia center air deflector (2). Tighten the screws to 2.5 N.m (22 lb in).

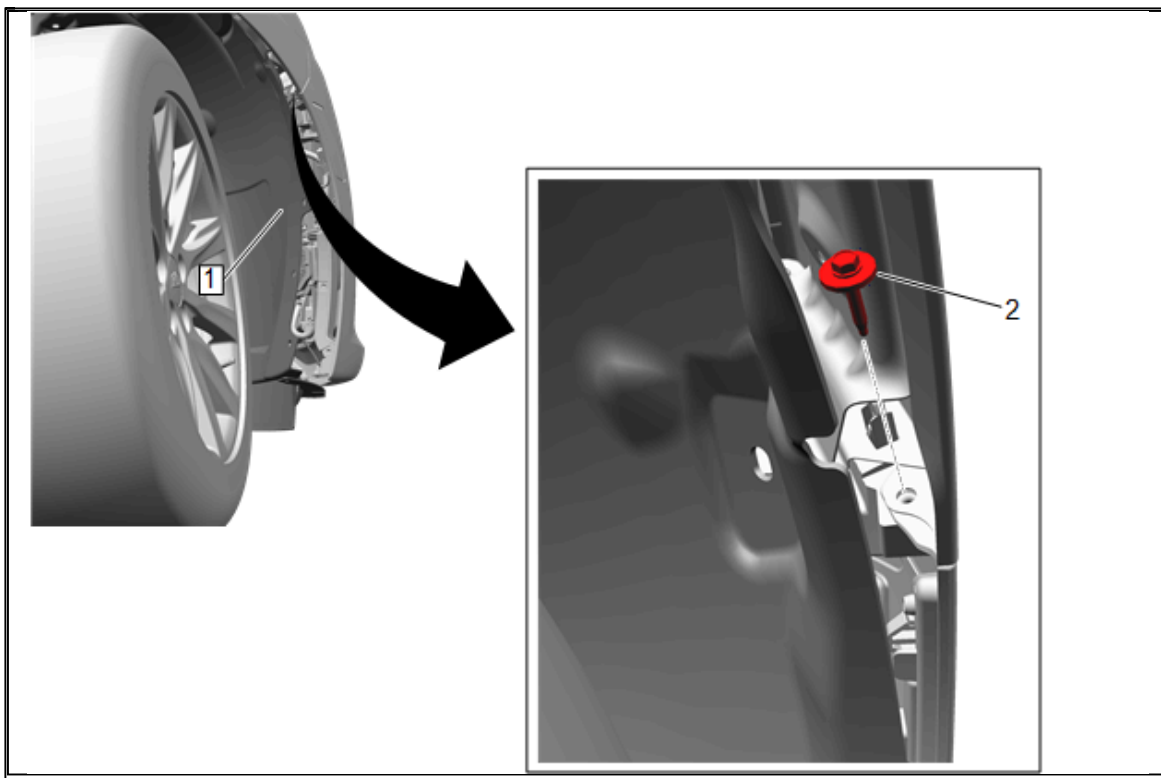

10. Reposition the right front wheelhouse liner (1) and install the right side upper front bumper fascia bolt (2). Tighten the bolt to 2.5 N.m (22 lb in).

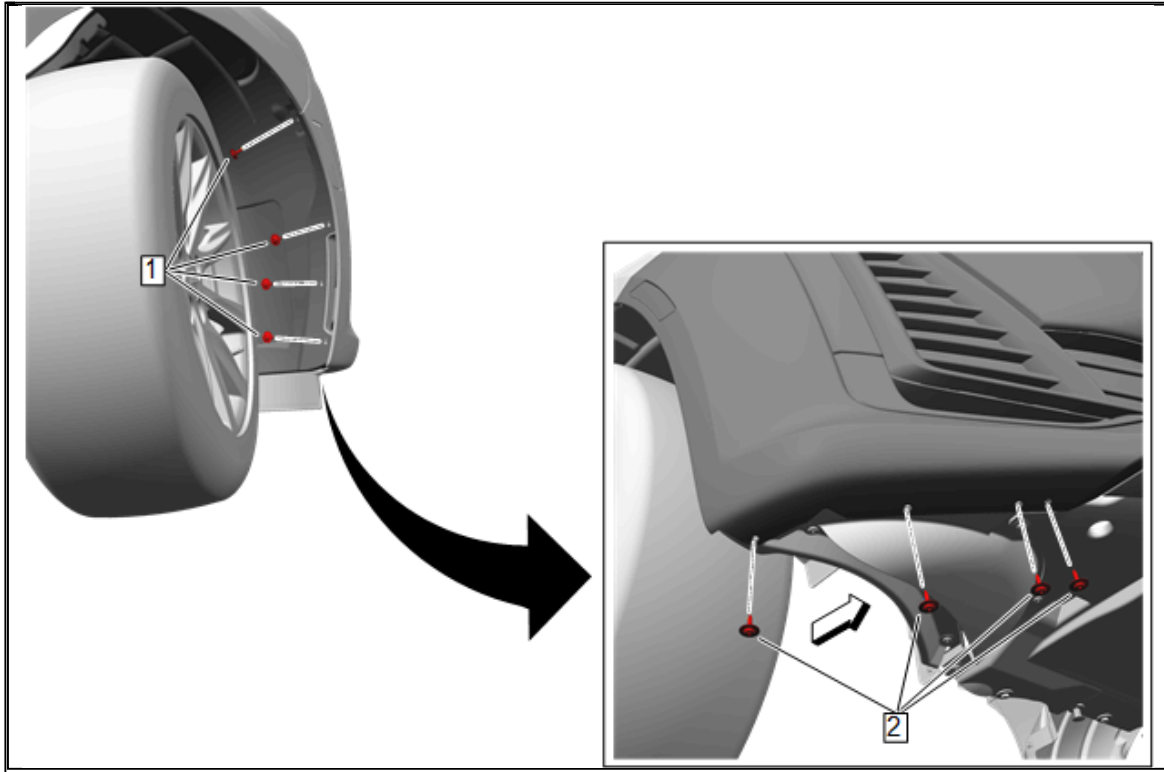

11. Install the 4 right side wheelhouse liner bolts (1). Tighten the bolts to 2.5 N.m (22 lb in).
12. Install the 4 right side front lower fascia bolts (2). Tighten the bolts to 2.5 N.m (22 lb in).

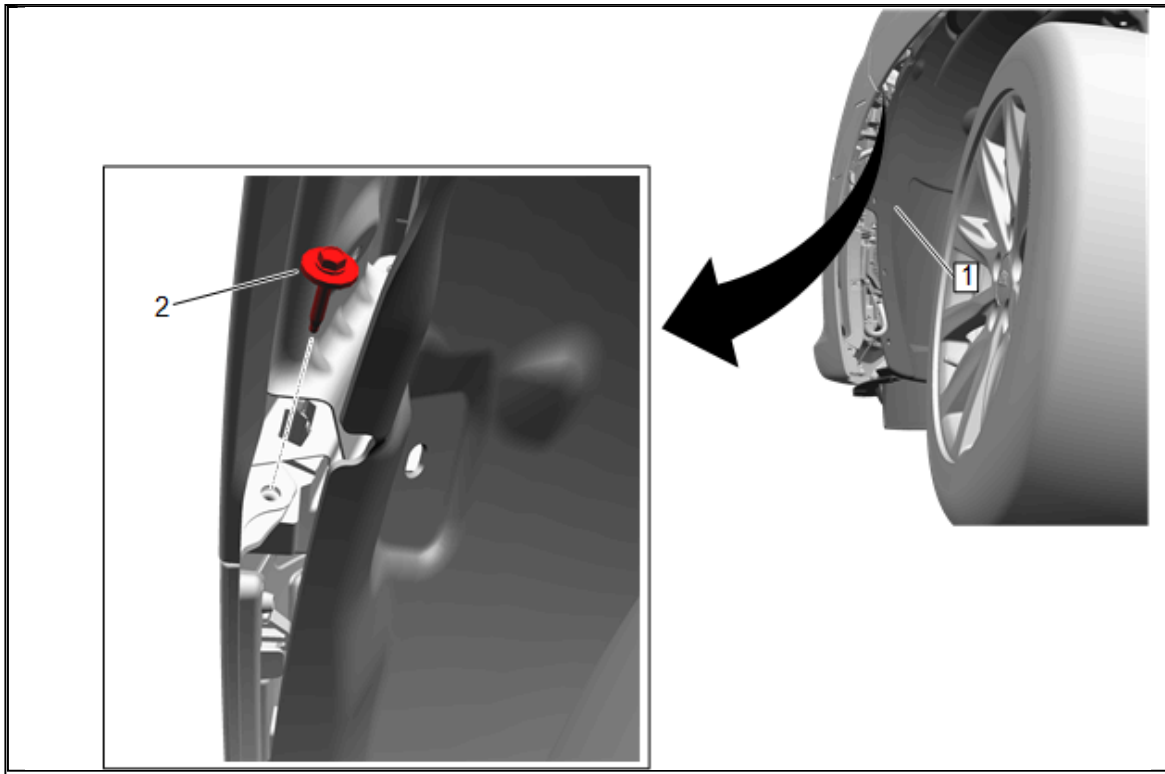

13. Reposition the left front wheelhouse liner (1) and install the left side upper front bumper fascia bolt (2). Tighten the bolt to 2.5 N.m (22 lb in).

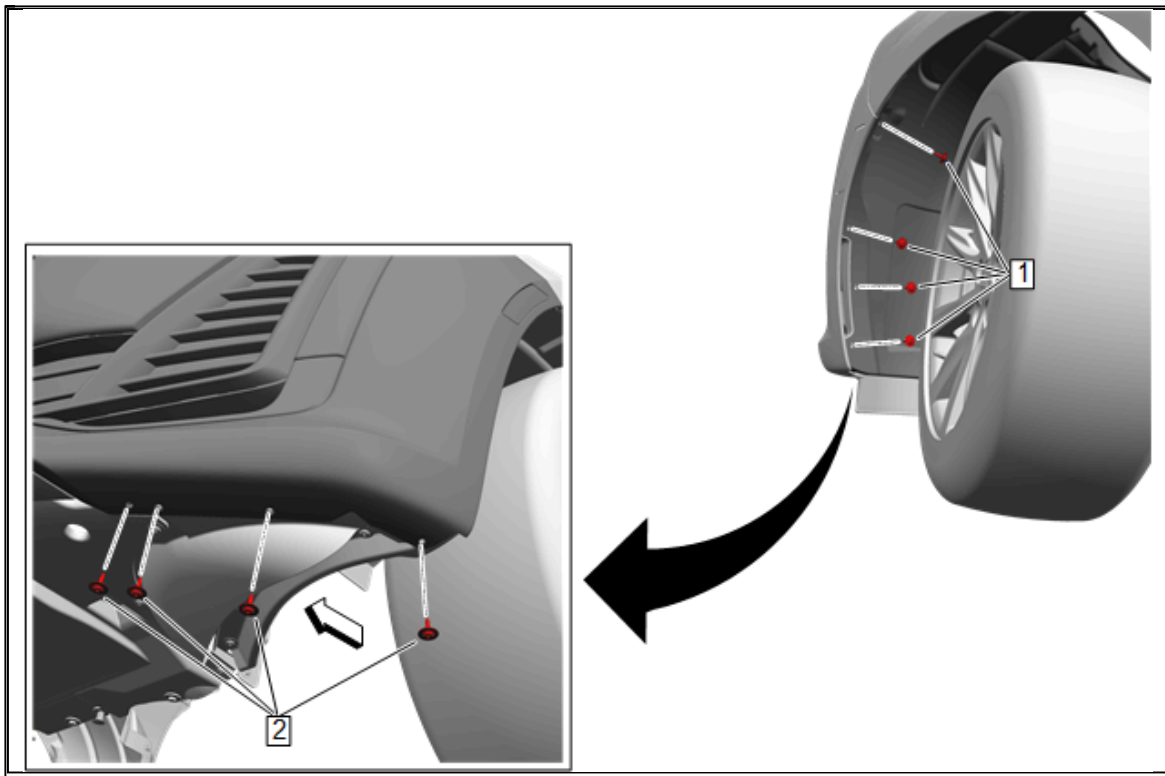

14. Install the 4 left side wheelhouse liner bolts(1). Tighten the bolts to 2.5 N.m (22 lb in).

15. Install the 4 left side front lower fascia bolts (2). Tighten the bolts to 2.5 N.m (22 lb in).

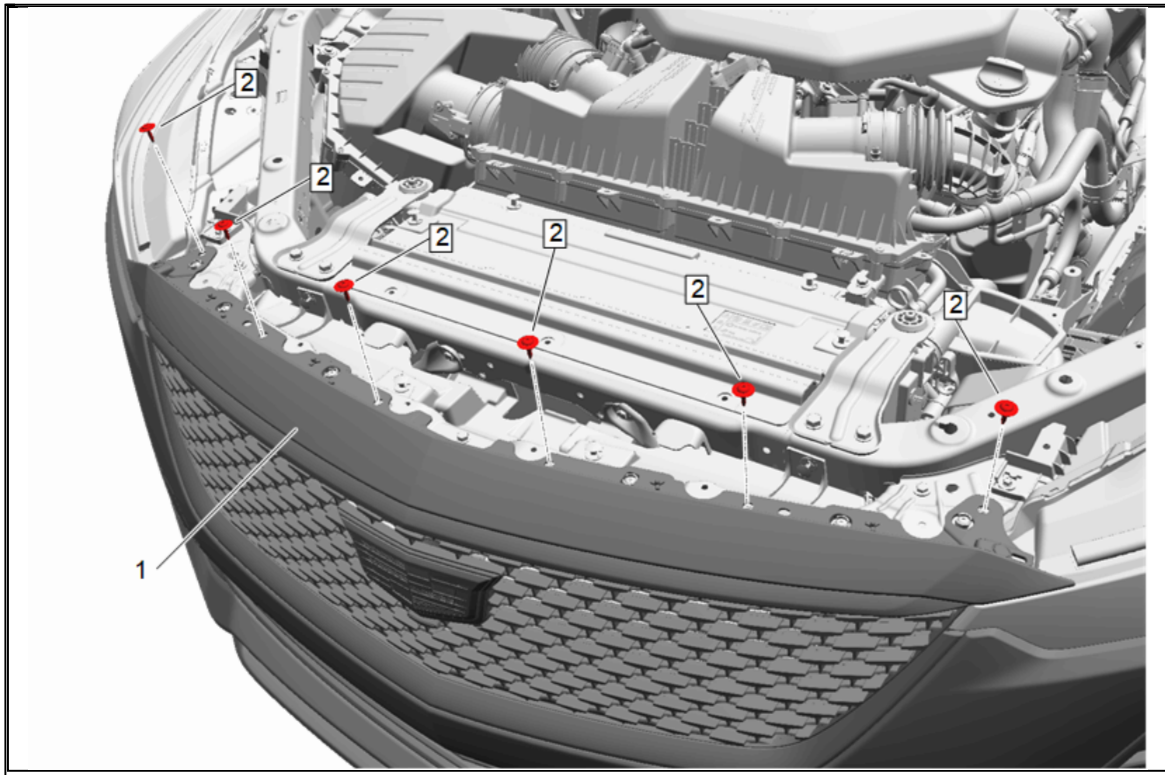

16. Install the upper bolts (2) to the front bumper fascia (1). Tighten the bolts to 2.5 N.m (22 lb in).

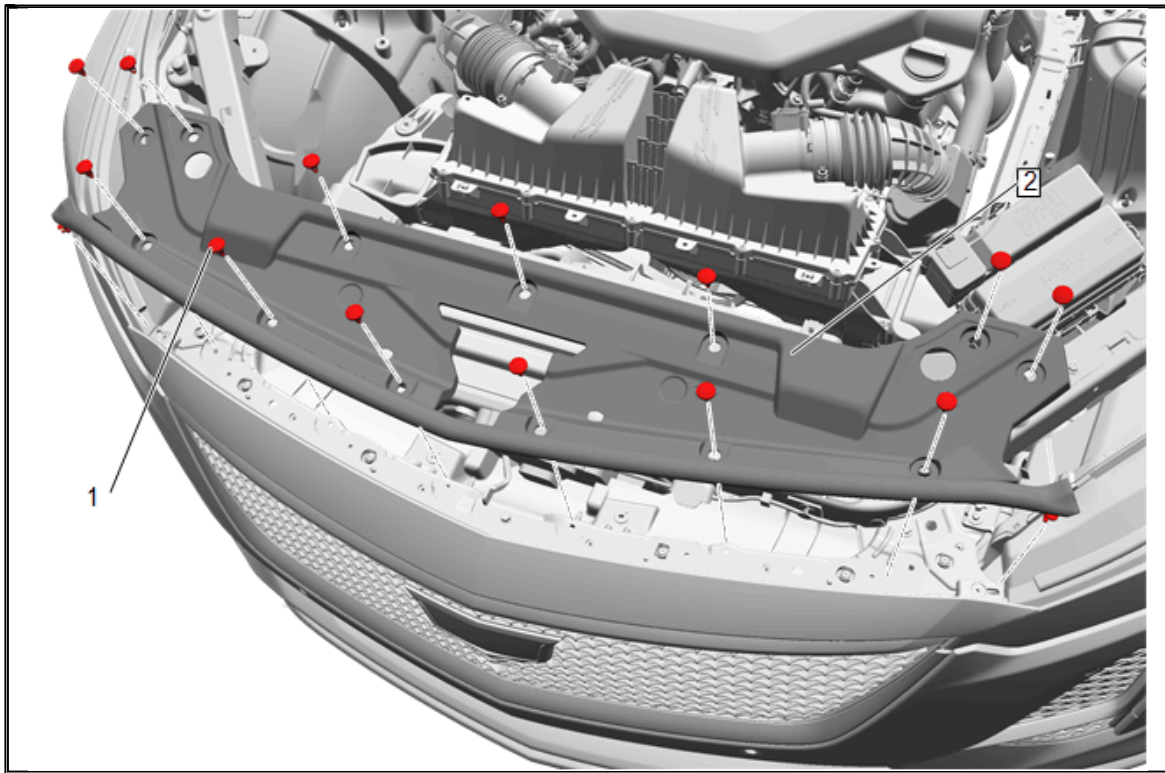

17. Install the front compartment front sight shield (2).
18. Install the retainers (1) Qty: 15 to the front compartment front sight shield.
19. { If equipped } Connect the engine coolant heater wiring extension harness connector to the license plate bracket.
20. Ensure all electrical connections are intact, test any front lighting to confirm it is functioning.
21. Remove the support and lower the vehicle.

### Remove Rear Emblem

1. Turn off vehicle.



**Caution:** Applying excessive heat to the emblem/nameplate may damage the paint and surrounding panel surfaces during removal. Heat temperature SHOULD NOT exceed 79°C (175°F).

2. Use a small flat-bladed tool to pull and release the rear compartment lid latch cover (1).
3. Rear Compartment Lid Latch Cover (1) » Remove

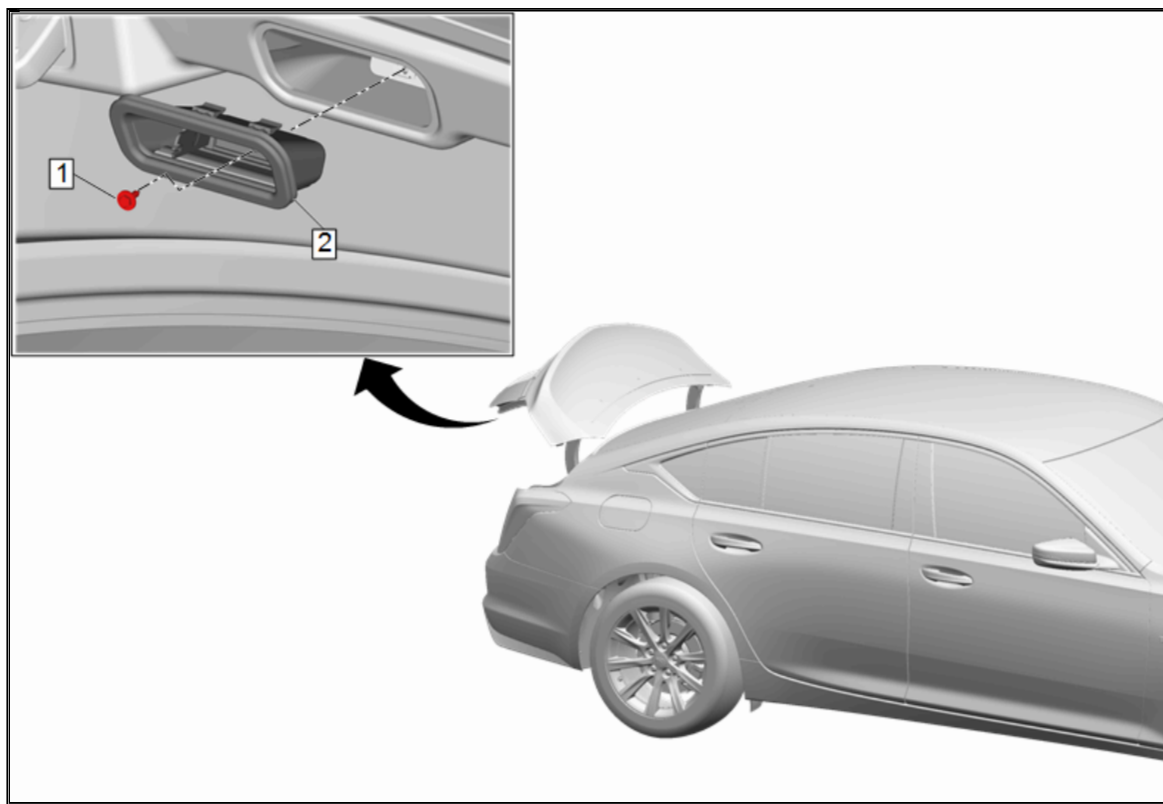

4. Using a small flat bladed tool, open the integral handle cover to access bolt.
5. Remove bolt (1) and rear compartment lid inside handle (2).

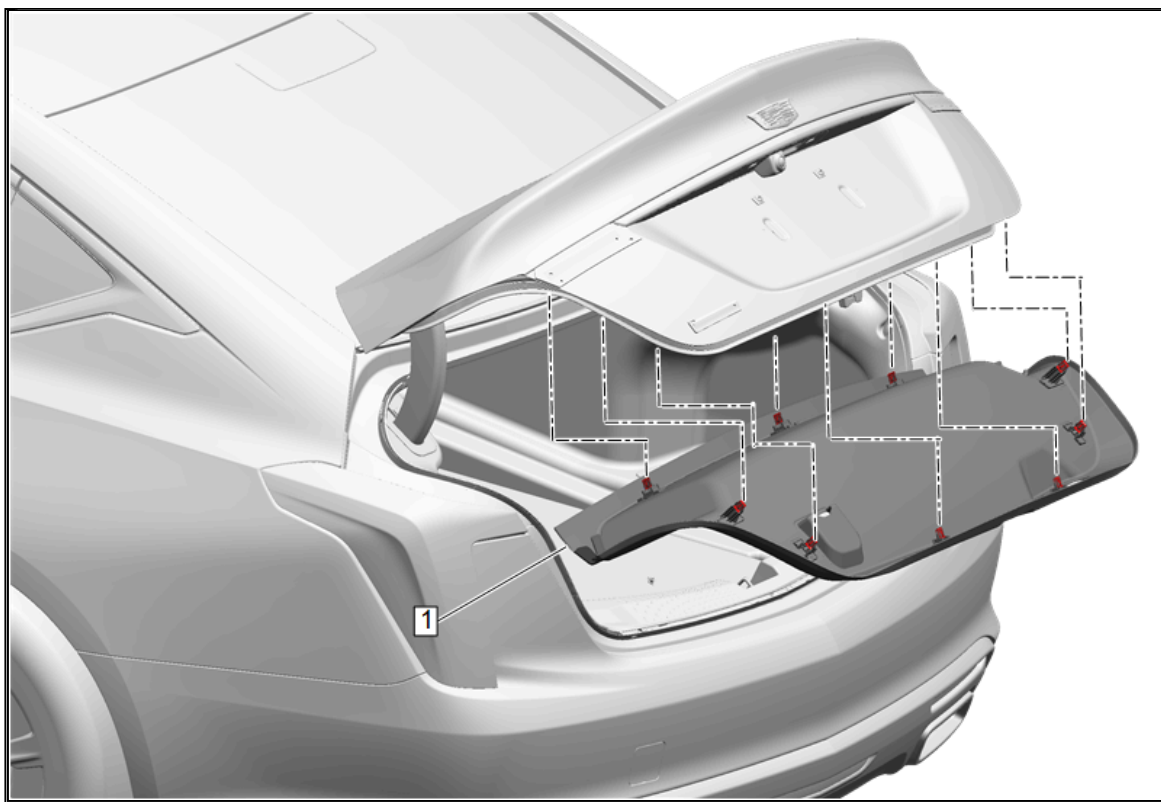

6. Use a flat-bladed plastic tool to disengage the push-in retainers from the sheet metal.
7. Rear Compartment Lid Inner Panel Trim (1) » Remove

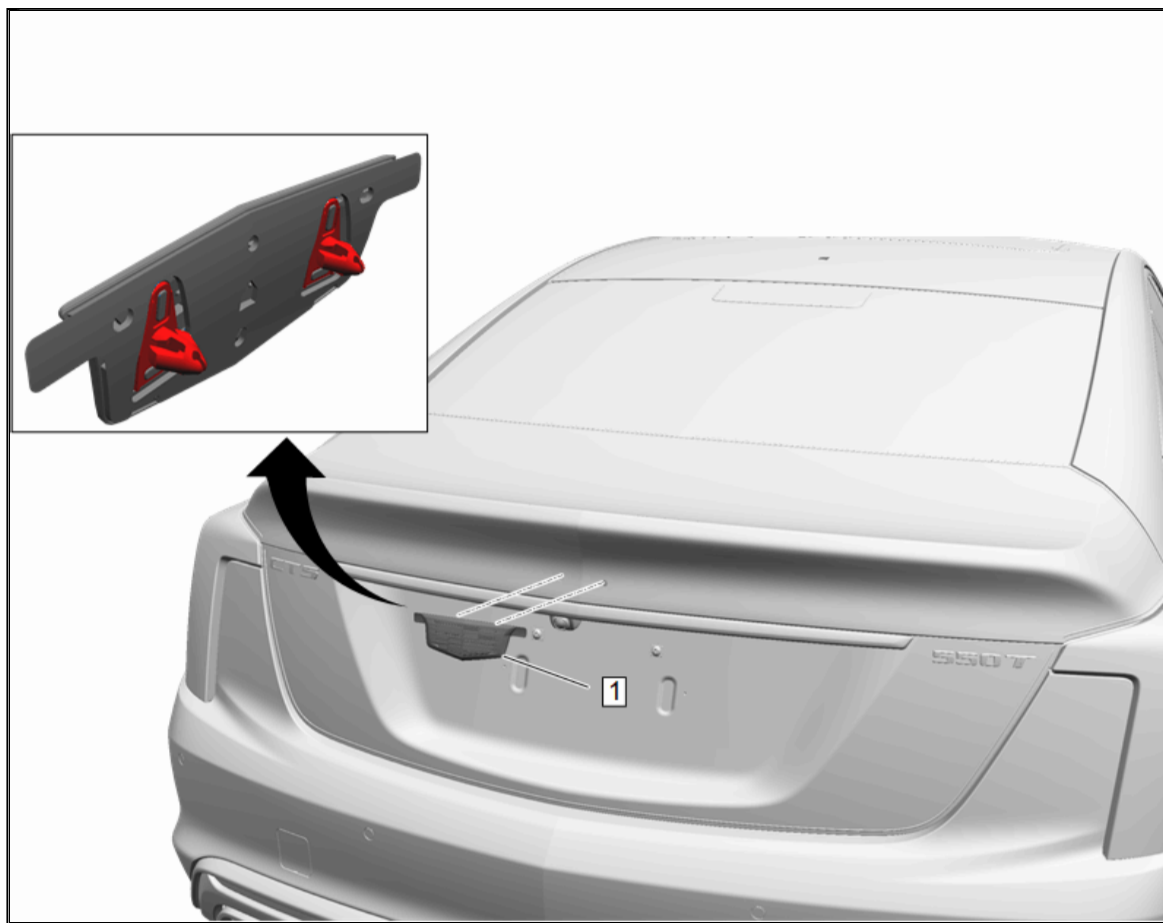

**Note:** Use caution during the steps to avoid marring or scratching the class "A" paint finish.

8. Apply two layers of masking tape around the rear compartment lid emblem/nameplate (1) to prevent paint damage.
9. Warm the rear compartment lid emblem/nameplate (1) using a hair dryer or heat gun not exceeding 79°C (175°F). Care should be given to protect the interfacing surface.
10. From inside the rear compartment lid, squeeze the retainer tabs together while gently prying the rear compartment lid emblem/nameplate (1) off the vehicle body using a suitable plastic trim tool.
11. Rear Compartment Lid Emblem/Nameplate (1) » Remove
12. Remove the masking tape.
13. Remove any remaining adhesive residue.
  - 13.1. Heavy foam/adhesive residue remaining on the painted surface can be removed using 3M's Scotch-Brite™ Molding Adhesive and Stripe Removal Disc (4 inch) or (6 inch). This disc will not damage the class "A" paint finish.
  - 13.2. Light adhesive residue remaining on the painted surface can be removed using 3M's General Purpose Adhesive Cleaner, or isopropyl alcohol, and a soft clean cloth.

### Install Rear Emblem

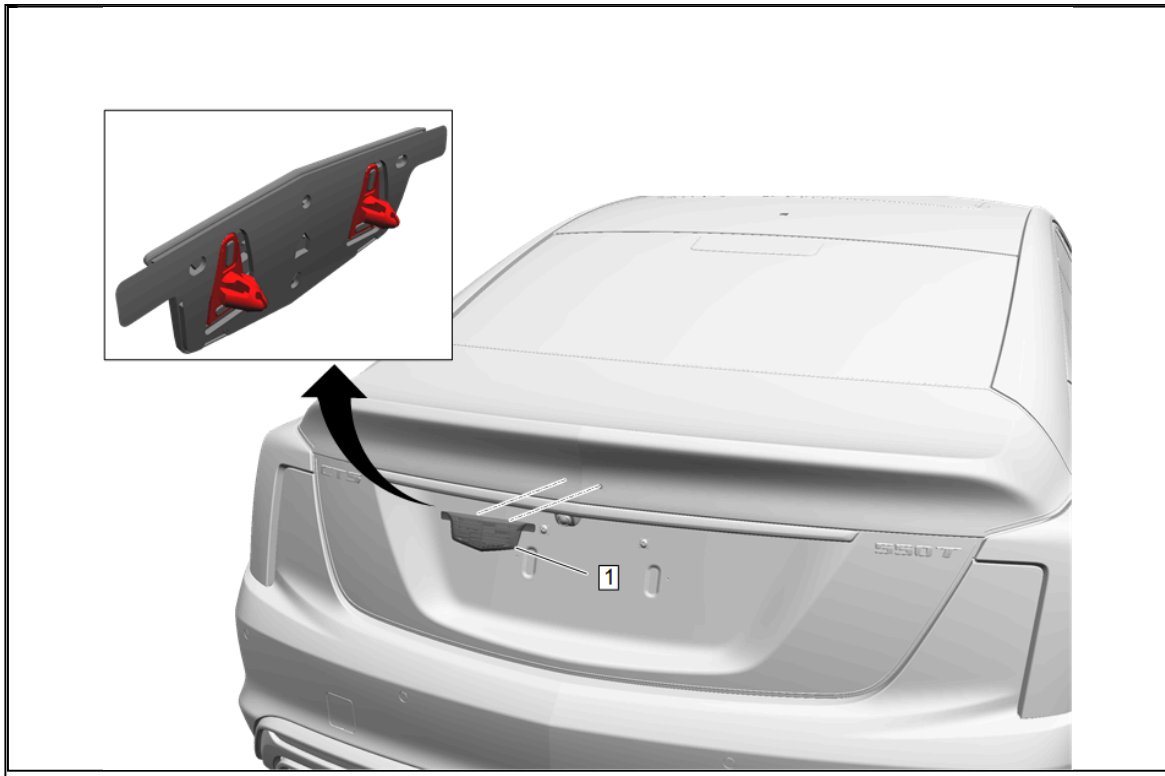

1. The painted surface must be clean and dry before installation of a new rear compartment lid emblem/nameplate (1).
  - 1.1. Temperature ranges required for installation of a new rear compartment lid emblem/nameplate (1) are 16°C (60°F) - 43°C (110°F) for the body and the emblem/nameplate.
  - 1.2. General surface contaminants such as dirt, dust, fingerprints, moisture, oil, etc., can be removed with a dry cleaning cloth from 3M (Scotch Brite High Performance Cloth), or Contec (Thunderbolt Cloth).
2. Rear Compartment Lid Emblem/Nameplate (1) » Install

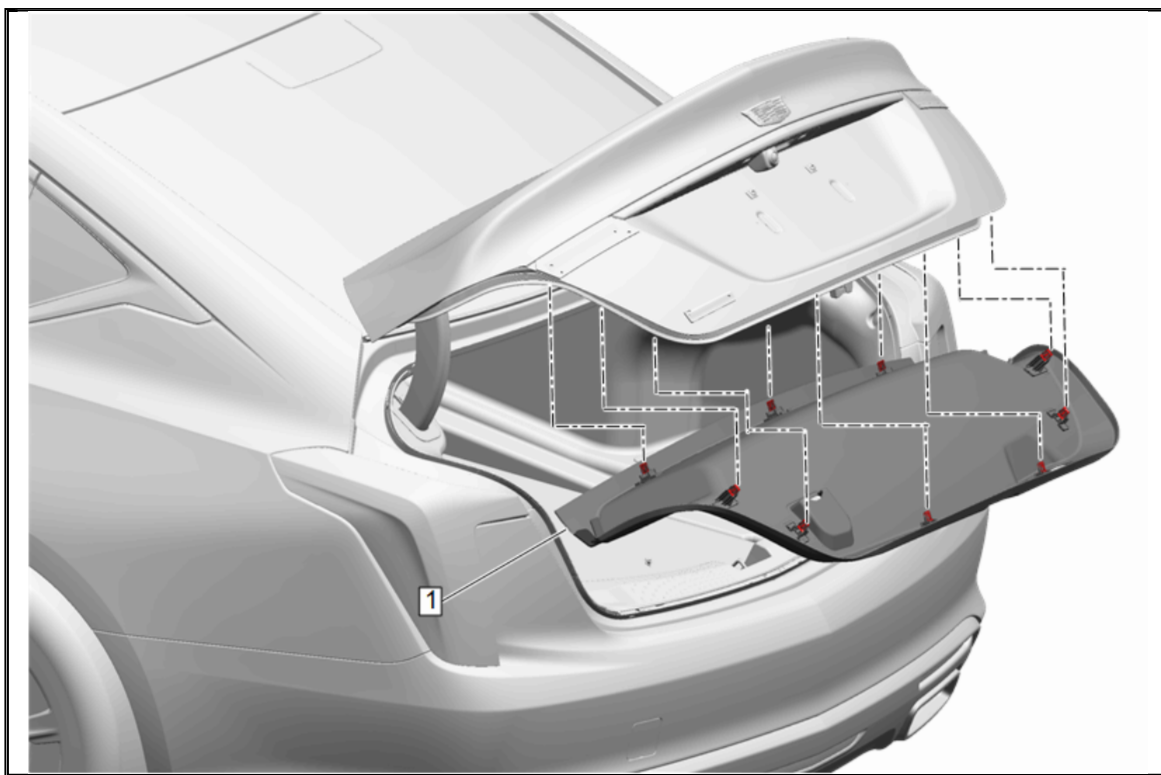

**Note:** Ensure the auxiliary rear compartment latch release handle is routed through the rear compartment lid inner panel trim.

3. Rear Compartment Lid Inner Panel Trim (1) » Install

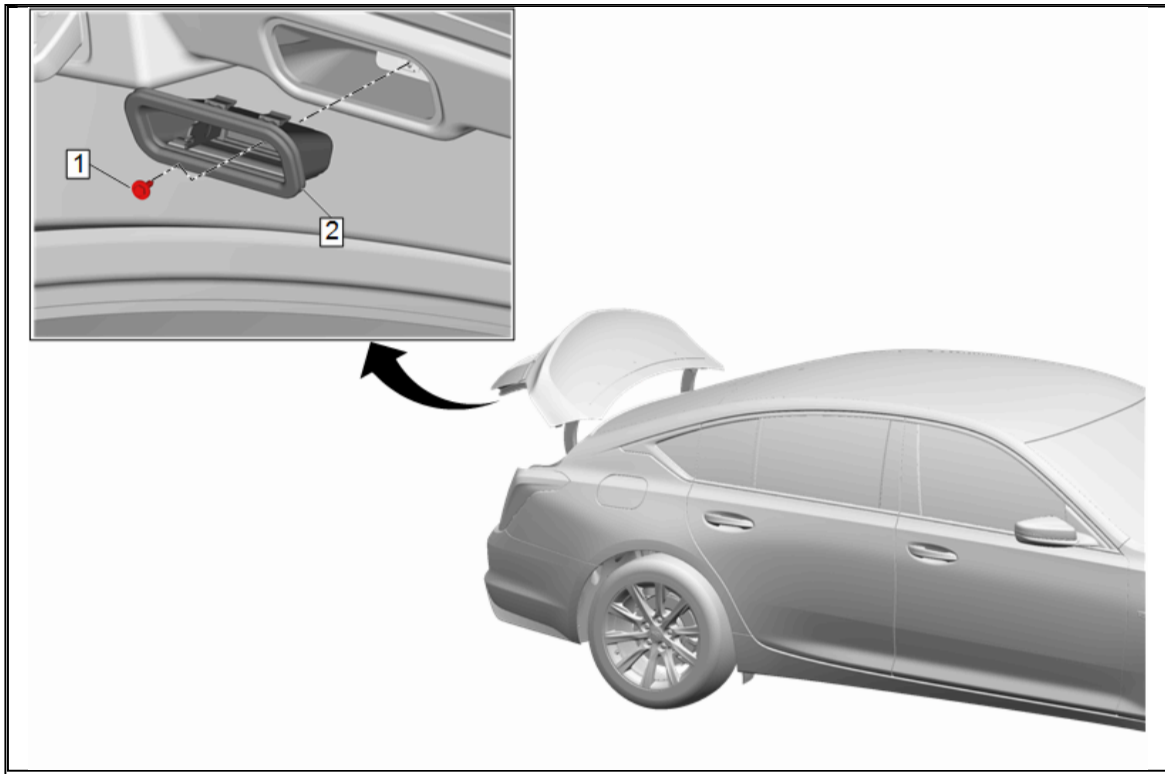

4. Install rear compartment lid inside handle (2) and bolt (1). Tighten the bolt to 2.5 N.m (22 lb in).



5. Rear Compartment Lid Latch Cover (1) » Install

