

# Cadillac XT5 | Document ID: 5552351

## Body Emblem Package Installation (Instruction ID: 84675915)

### Installation Instructions Part Number

84675915

### Kit Contents

Qty	Description
1	Emblem Assembly – Front
1	Emblem Assembly – Liftgate
1	Alcohol Wipe
1	Installation Instructions

### Tools Required

Flat bladed plastic trim tool

Masking tape

### Procedure

#### Remove Front Emblem

1. Read all instructions before performing procedure.
2. Inspect kit to verify all parts are included.
3. Turn off the vehicle.
4. Raise and support the vehicle. Refer to [Lifting and Jacking the Vehicle](#) in Vehicle Service Manual.
5. Open hood.

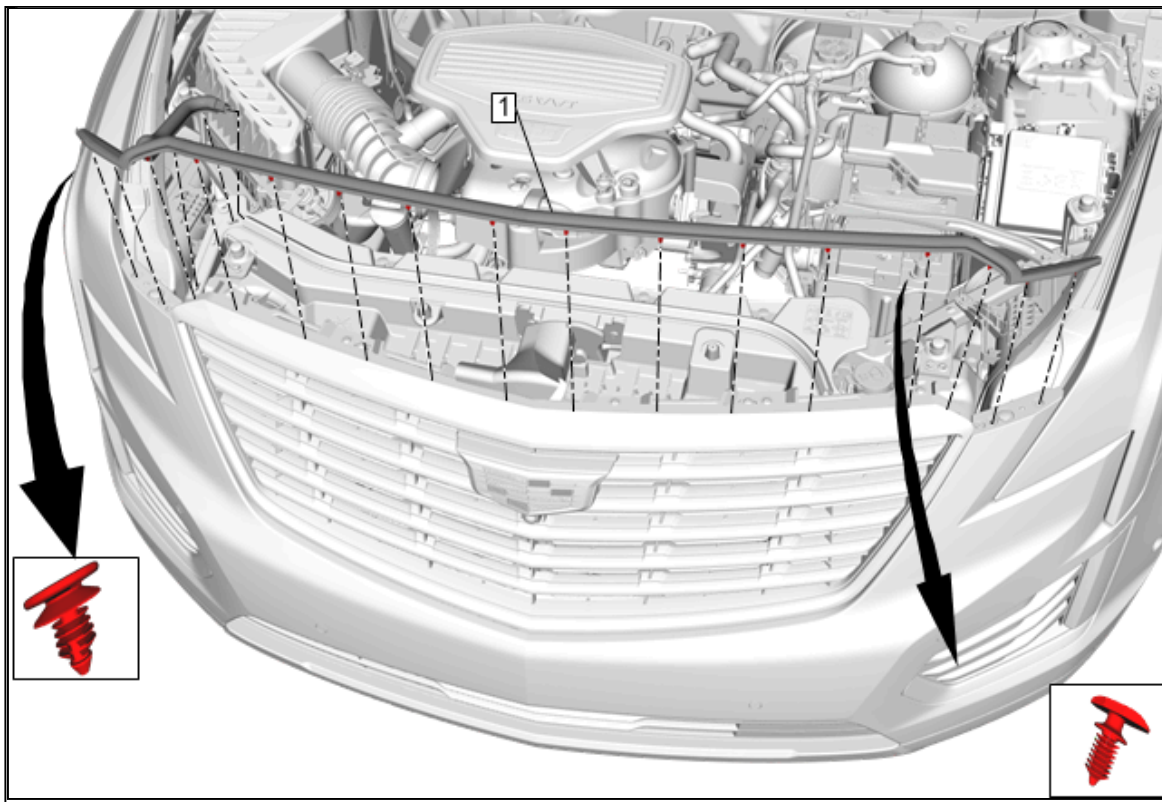

6. Using a trim type tool, release the integral retainers from the front grille and remove hood front edge weather-strip (1).

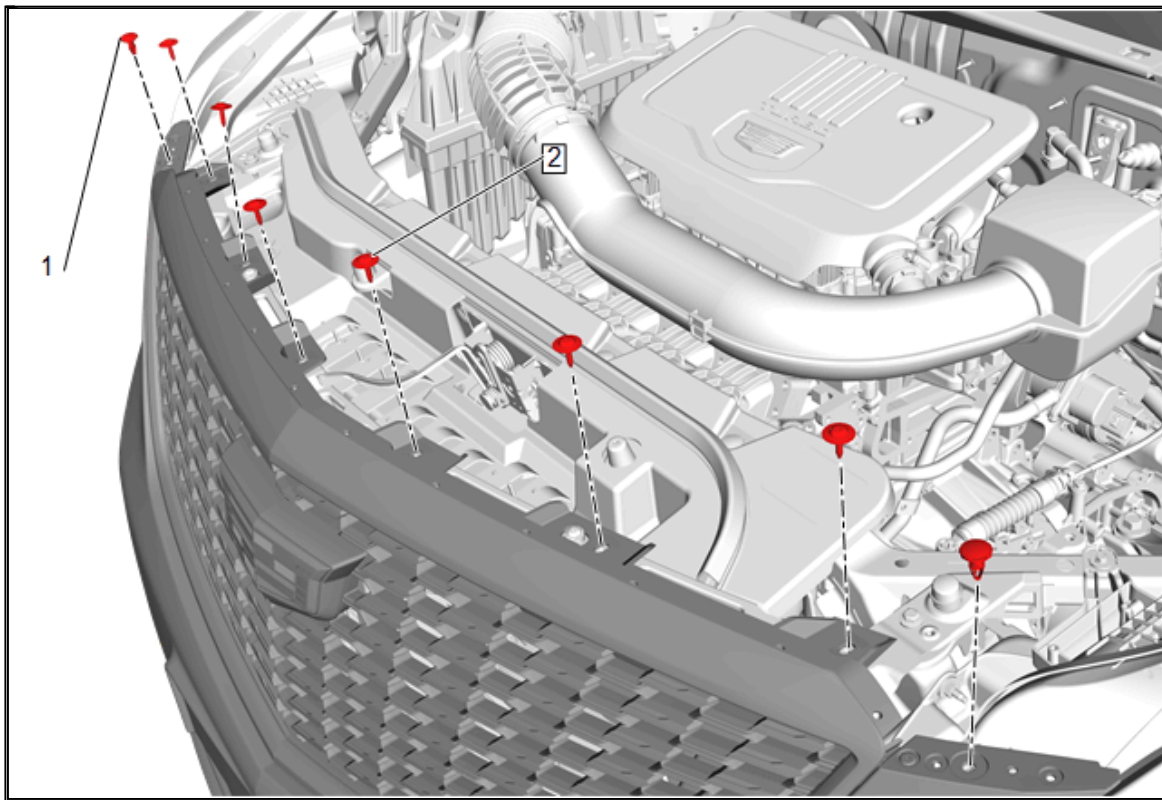

7. Front Bumper Fascia Retainer (1) » Remove [2x]

8. Front Bumper Fascia Bolt (2) » Remove [6x]

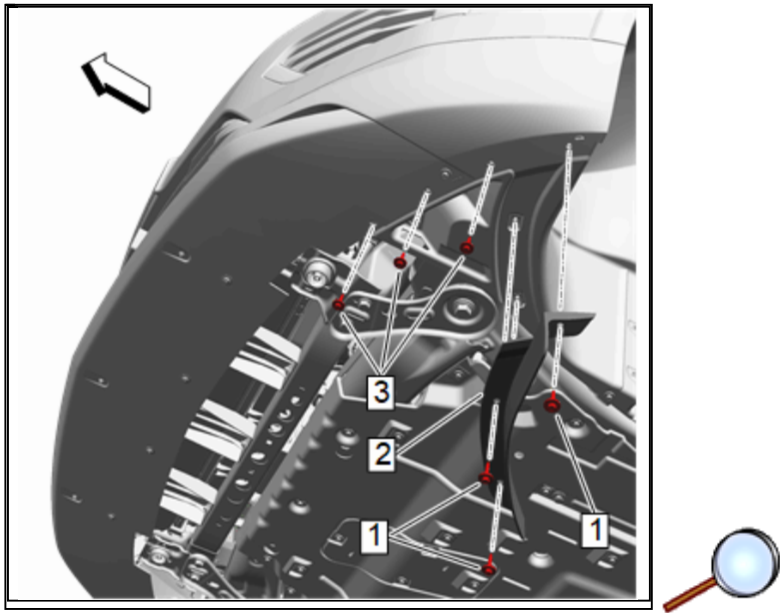

9. Remove the left front air deflector bolts (1) and air deflector (2).

10. Remove the 3 left side front lower fascia bolts (3).

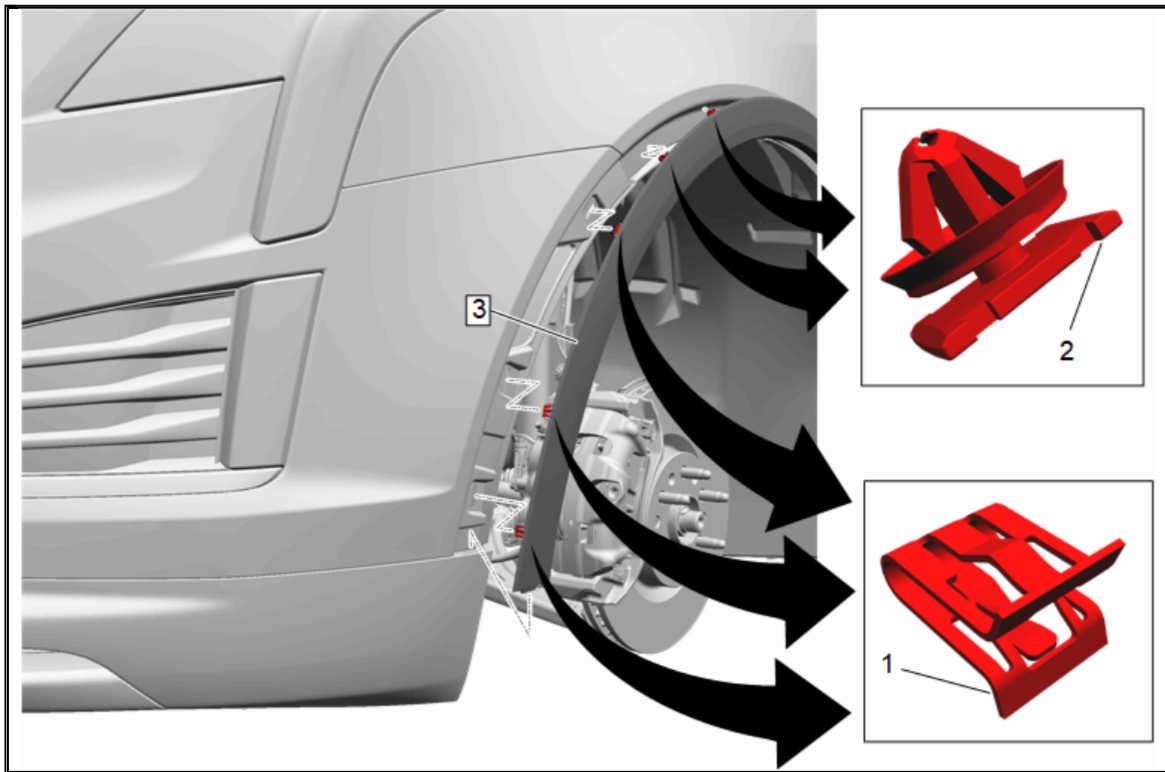

**Note:** Complete removal of front wheel opening molding is not required.

11. Apply two layers of masking tape around the edge of the left front wheel opening molding to prevent any paint surface damage.

12. Using a suitable flat bladed plastic tool, release the 3 clips (1) and 2 retainers (2) from around the front bumper fascia and the top front fender.
13. Pull upward to release the molding from the front bumper lower fascia.

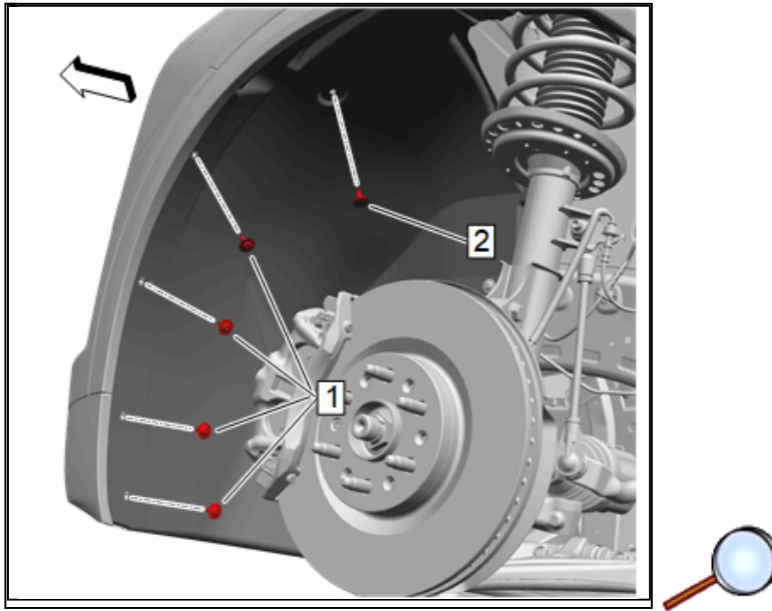

**Note:** Complete removal of wheel house liner is not required.

14. Remove the 4 left side wheelhouse liner bolts (1).
15. Remove the left side wheelhouse liner push retainer (2).

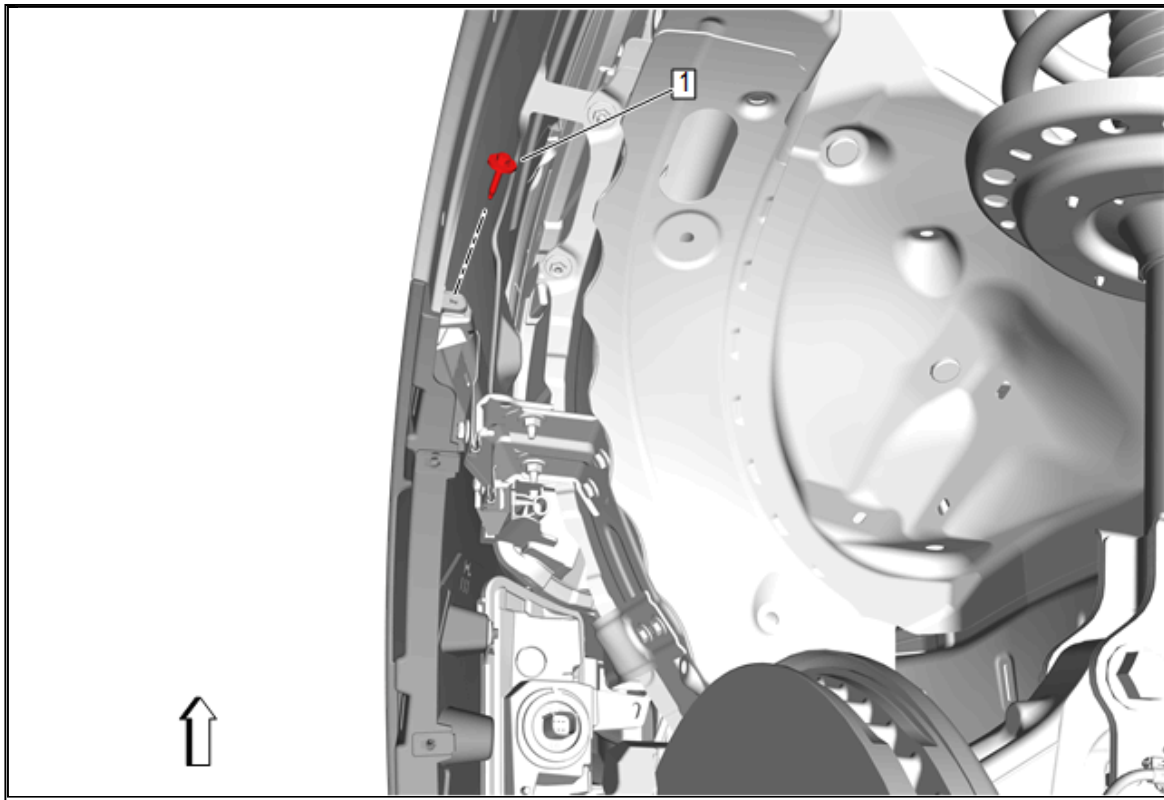

16. Reposition the left front wheelhouse liner to gain access to the left side upper front bumper fascia bolt.

17. Remove the left side upper front bumper fascia bolt (1).

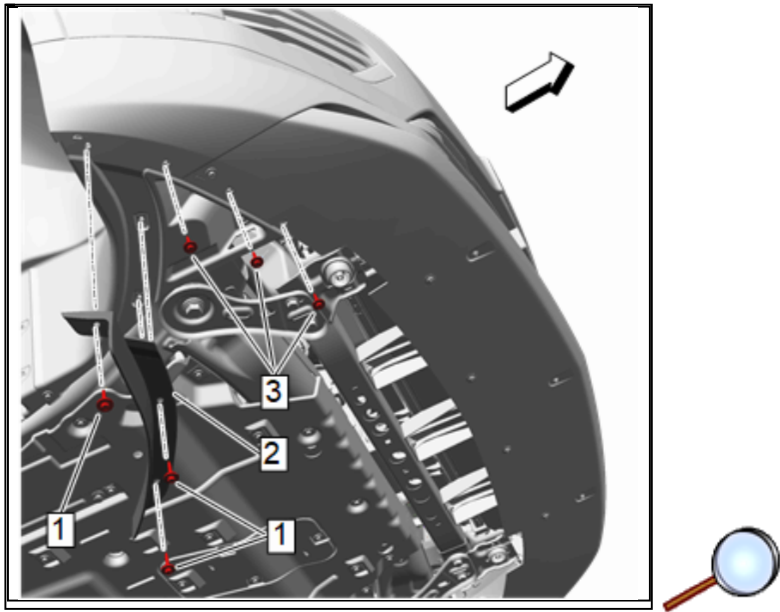

18. Remove the right front air deflector bolts (1) and air deflector (2).

19. Remove the 3 right side front lower fascia bolts (3).

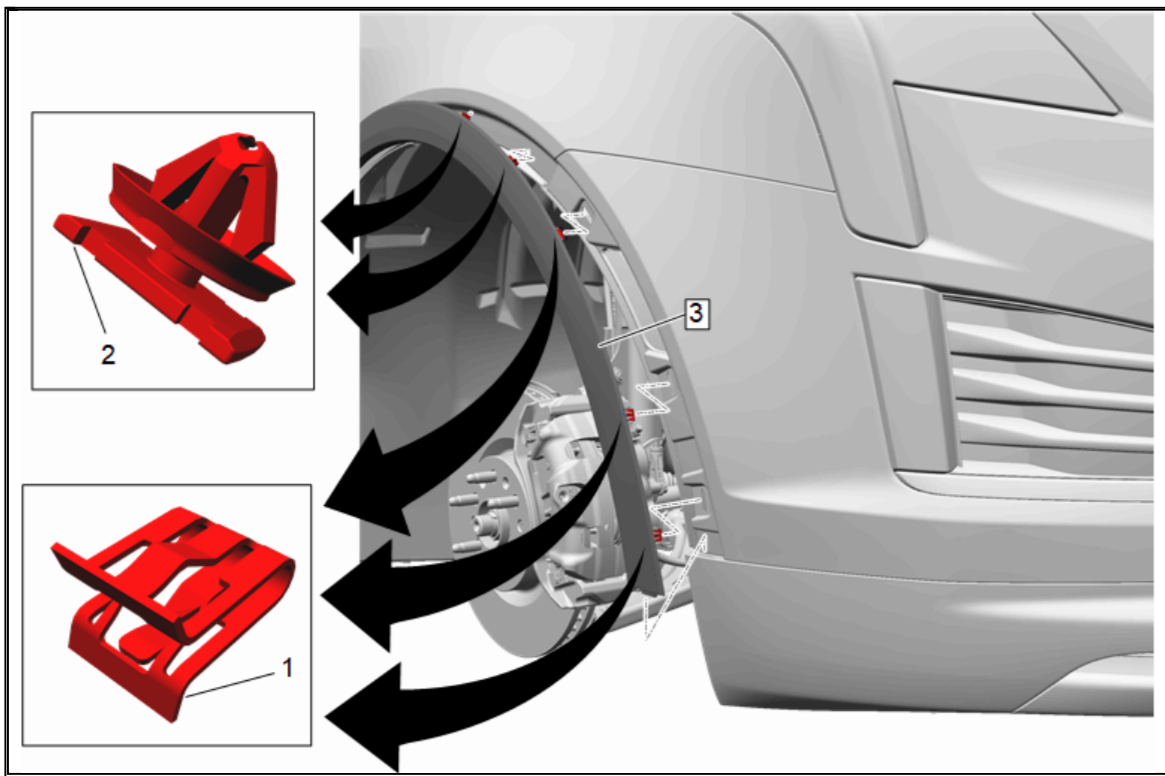

**Note:** Complete removal of front wheel opening molding is not required.

20. Apply two layers of masking tape around the edge of the right front wheel opening molding to prevent any paint surface damage.
21. Using a suitable flat bladed plastic tool, release the 3 clips (1) and 2 retainers (2) from around the front bumper fascia and the top front fender.
22. Pull upward to release the molding from the front bumper lower fascia.

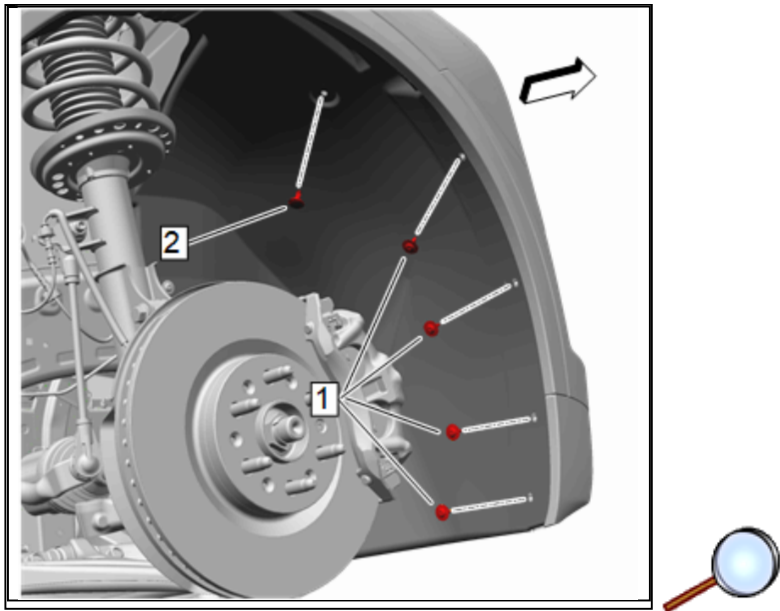

**Note:** Complete removal of wheel house liner is not required.

23. Remove the 4 right side wheelhouse liner bolts (1).
24. Remove the right side wheelhouse liner push retainer (2).



25. Reposition the right front wheelhouse liner to gain access to the right side upper front bumper fascia bolt.
26. Remove the right side upper front bumper fascia bolt (1).

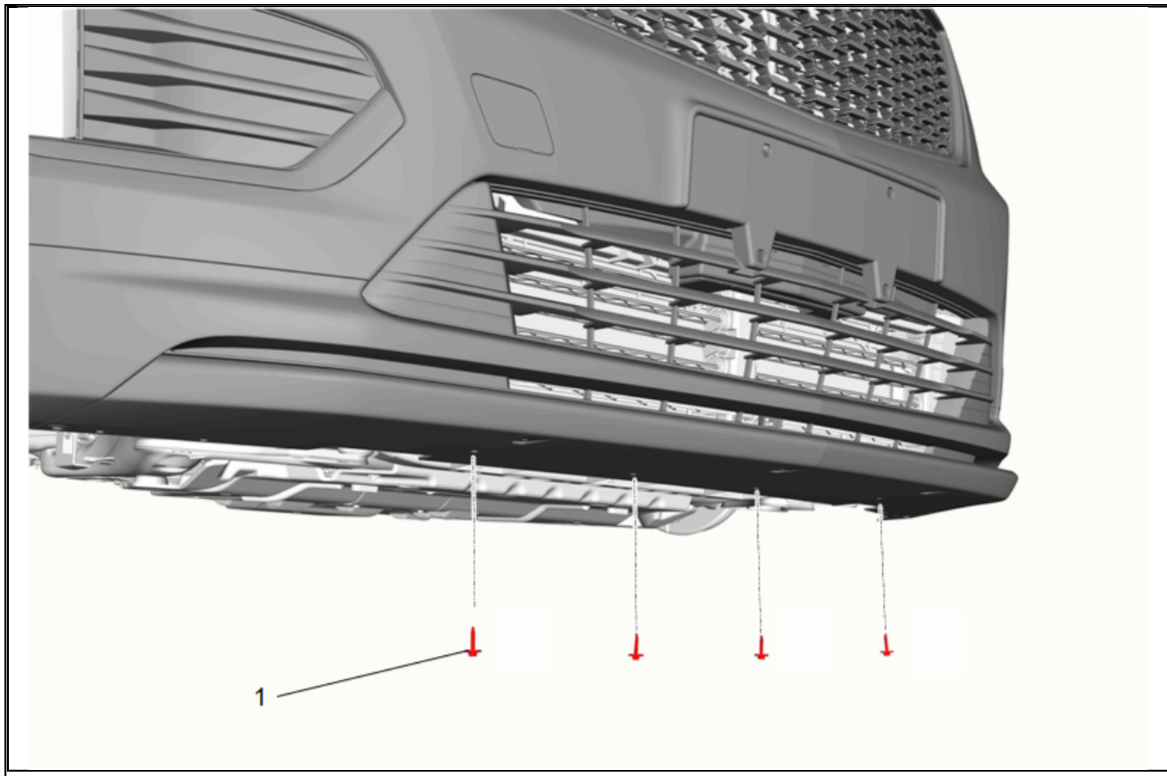

27. Front Bumper Fascia Bolt (1) » Remove [7x]

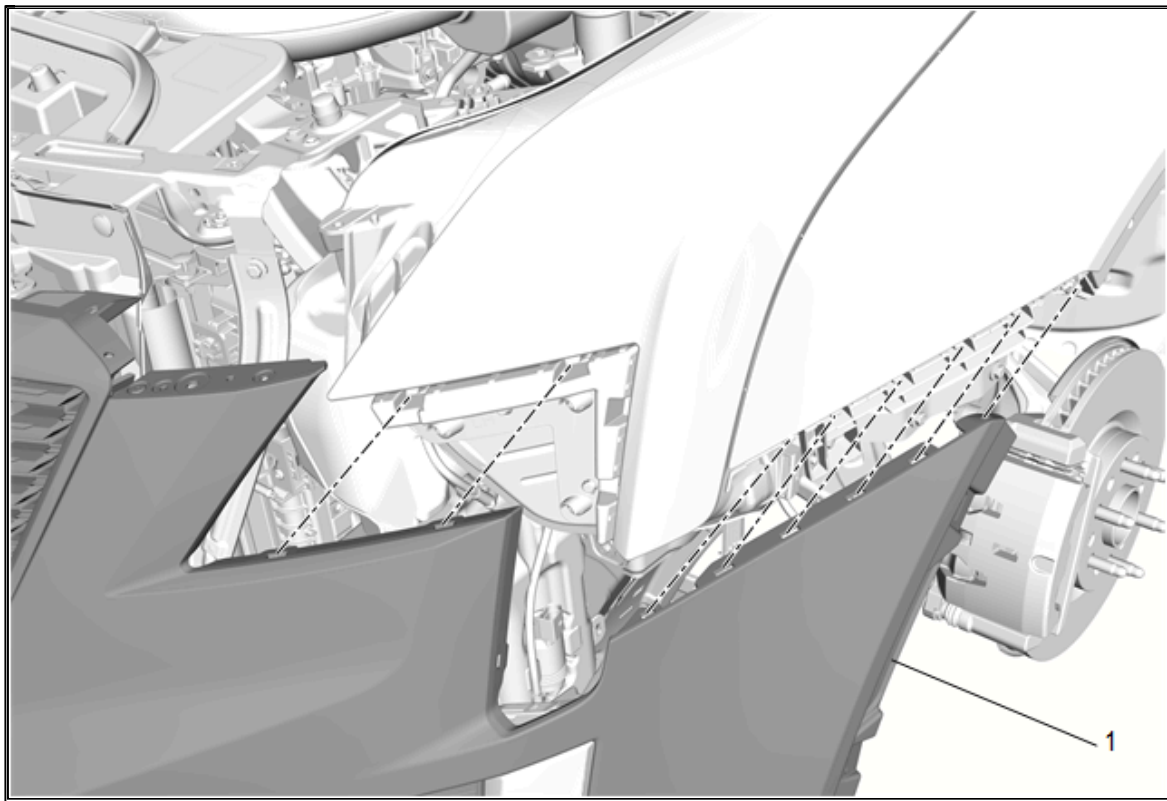

28. Carefully push a small nylon wedge between the fascia (1) and the fascia guide on both sides. Insert a small flat-bladed tool into the fascia slot and depress the snaps one at a time and pull on the fascia at the same time to gradually remove the fascia.

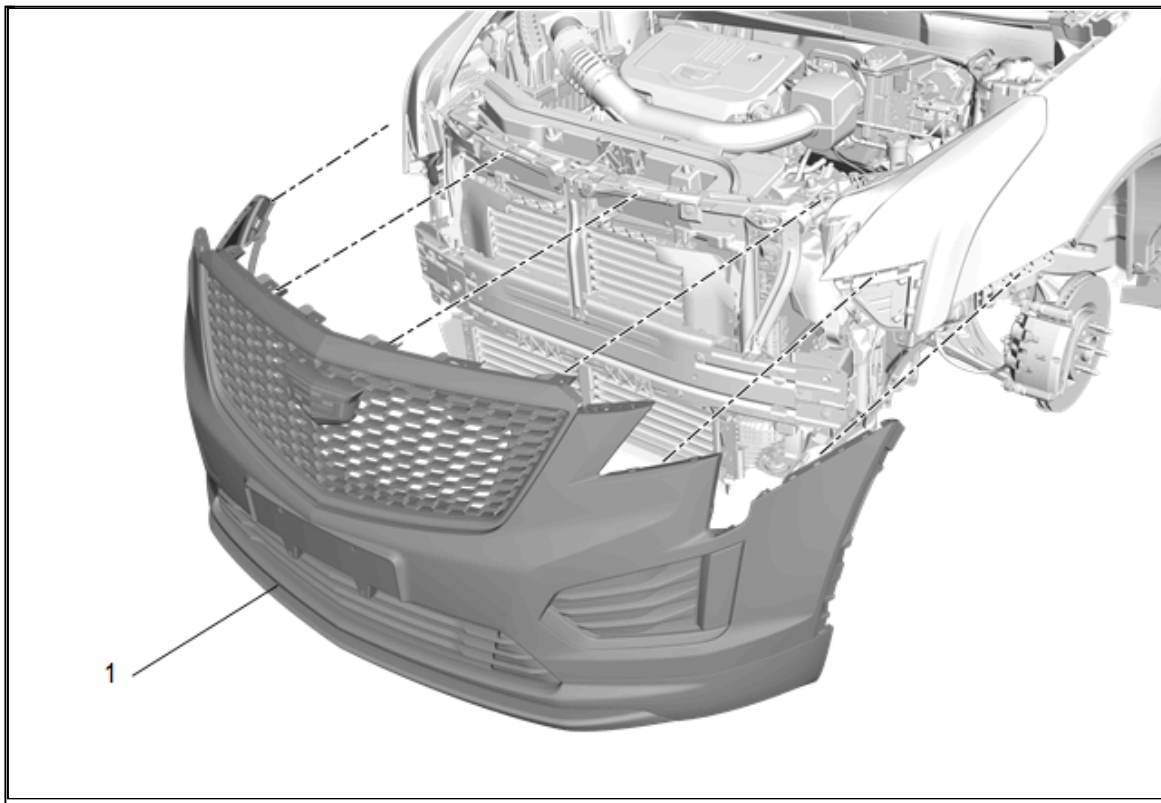

29. With the aid of an assistant, remove the fascia. (1)  
30. Disconnect all electrical connectors.  
31. Place the front bumper fascia on a clean suitable work surface to prevent damage.

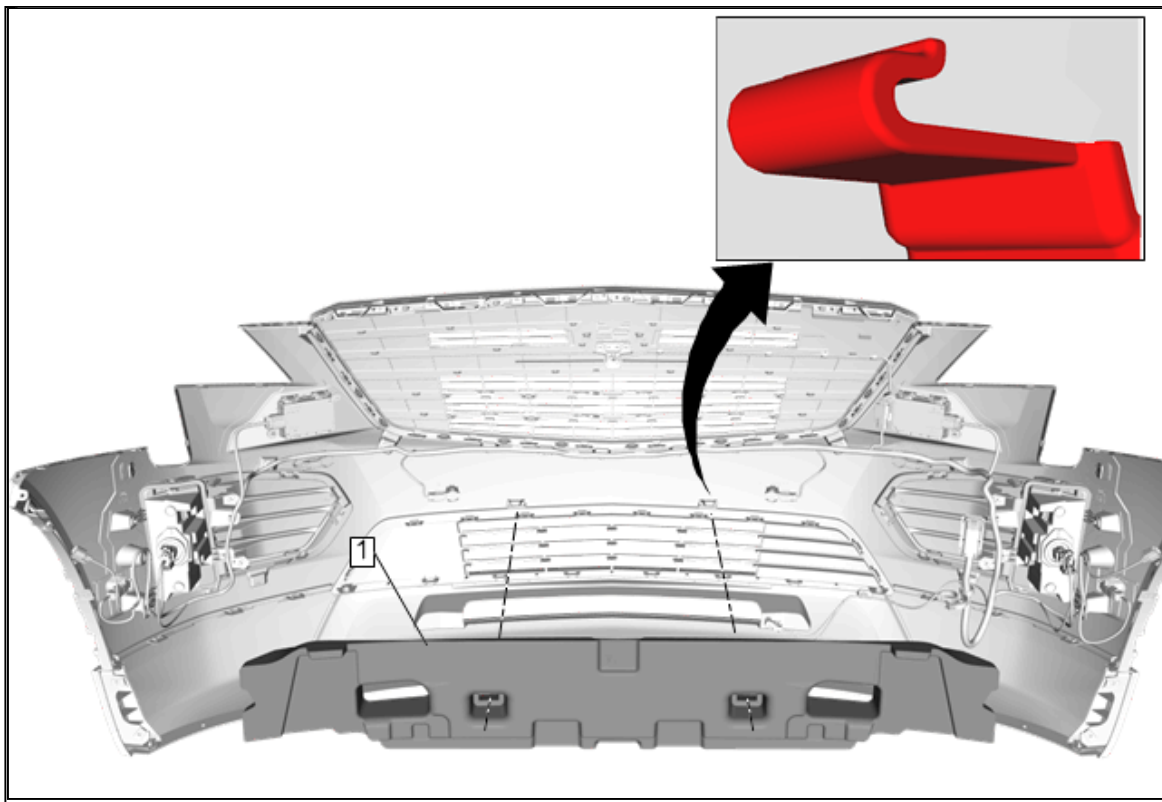

- 32. Reposition the fascia wiring harness and release the 2 retainers to remove the front bumper fascia energy absorber (1) from the fascia.

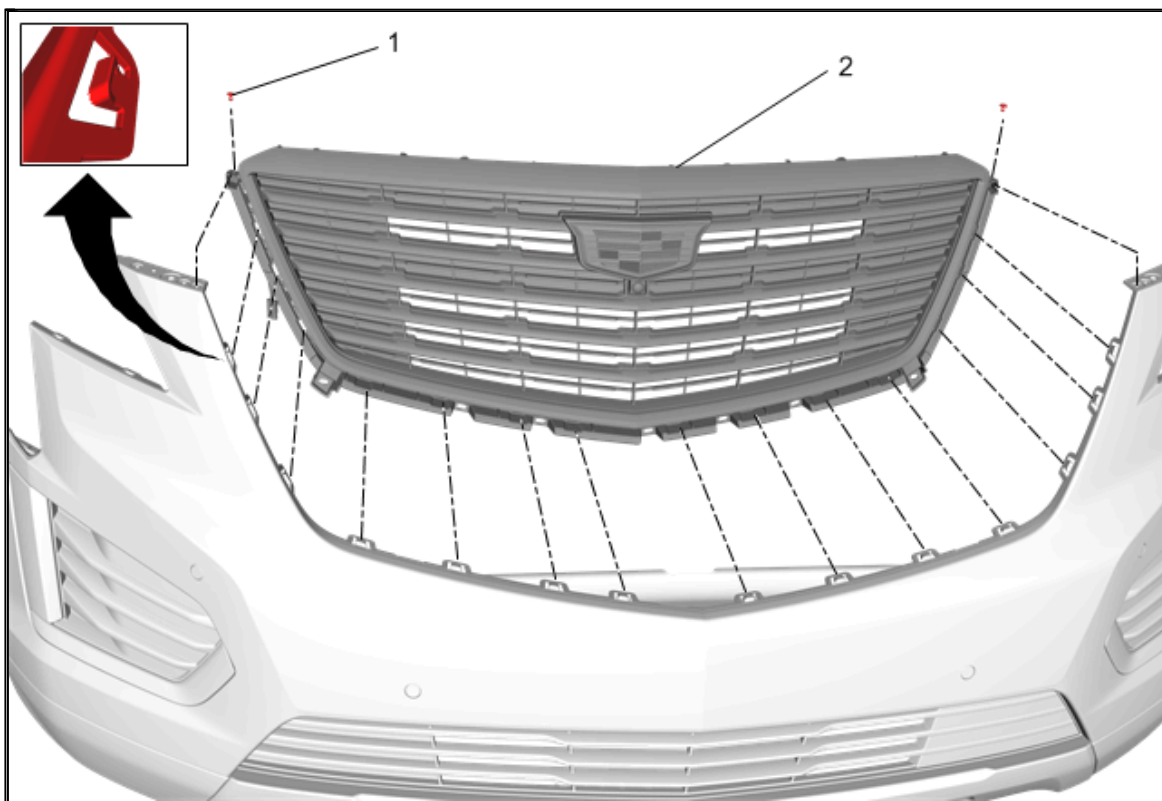

**Warning:** Use the proper eye protection when drilling to prevent metal chips from causing physical injury.

33. Drill and remove the two upper rivets (1) qty:2 from the front bumper upper fascia.
34. Reposition the fascia wiring harness and release the front grille from the front bumper fascia grille tabs.
35. Pull the front grille (2) from the backside of the front bumper fascia.

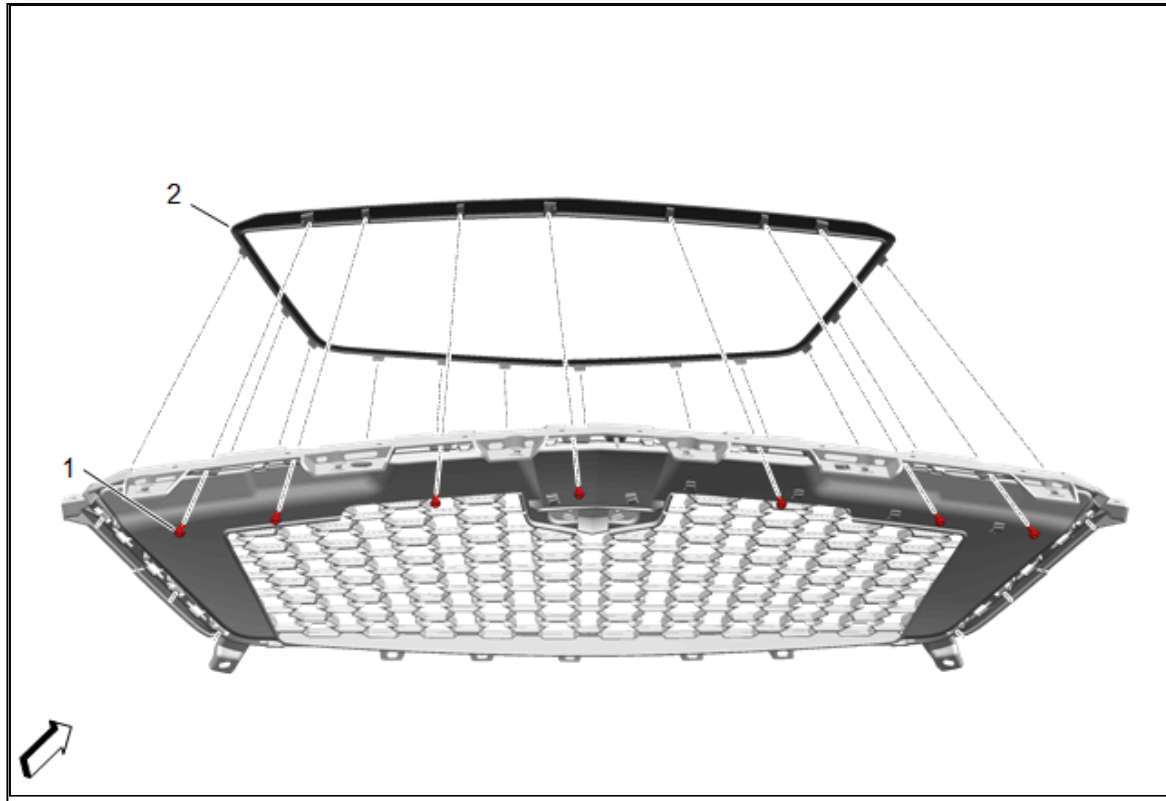

36. Remove the bolts (1) qty:7 from the front grille.
37. Using a suitable trim tool, release the locking tabs while carefully pulling the front grille opening bezel (2) from the front grille.

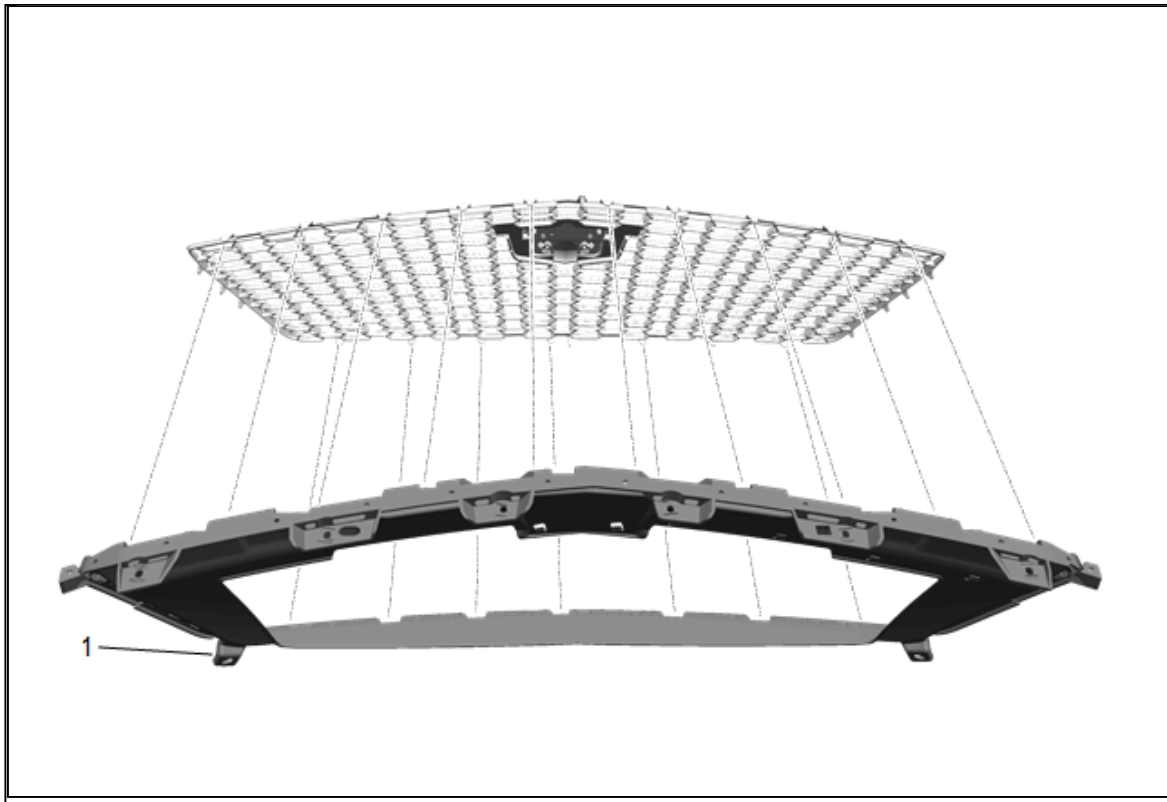

38. Release the locking tabs and pull the front grille filler (1) away from the front grille.

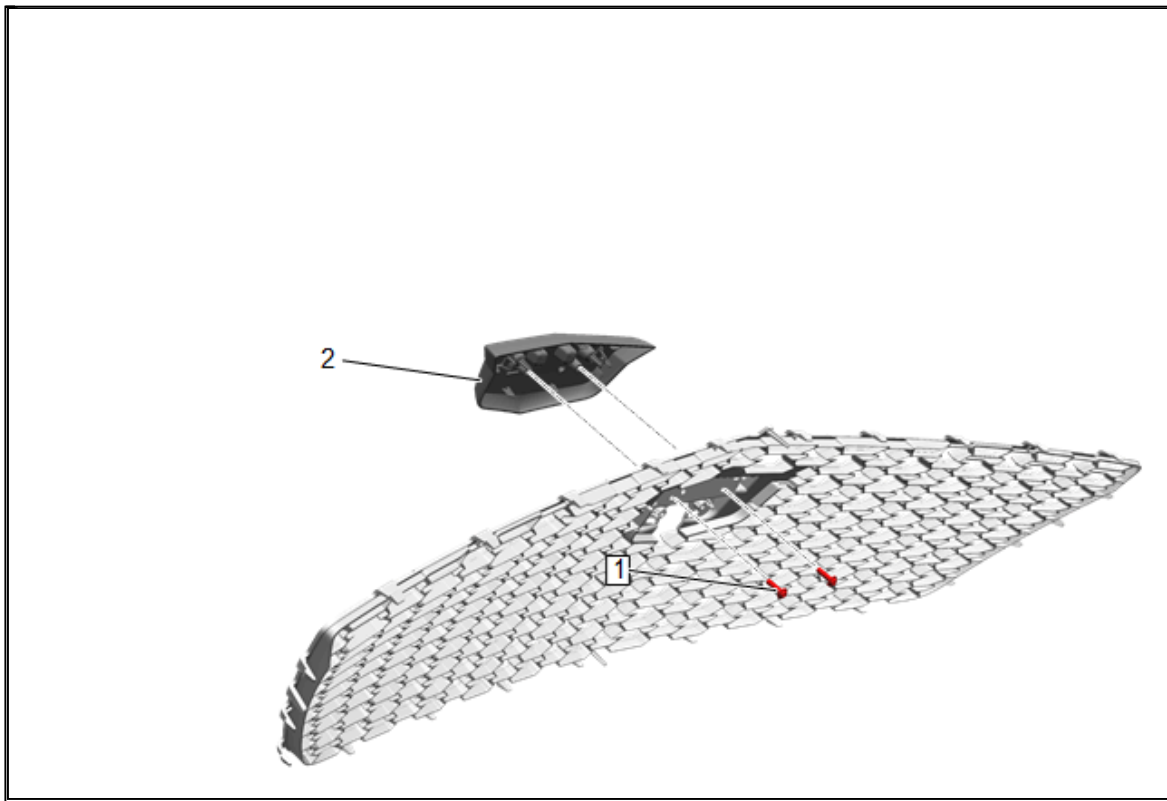

39. Remove the bolts (1) qty:2 from the front grille emblem adapter.
40. Using a suitable trim tool, release the locking tabs while carefully pulling the front grille emblem adapter (2) from the front grille.

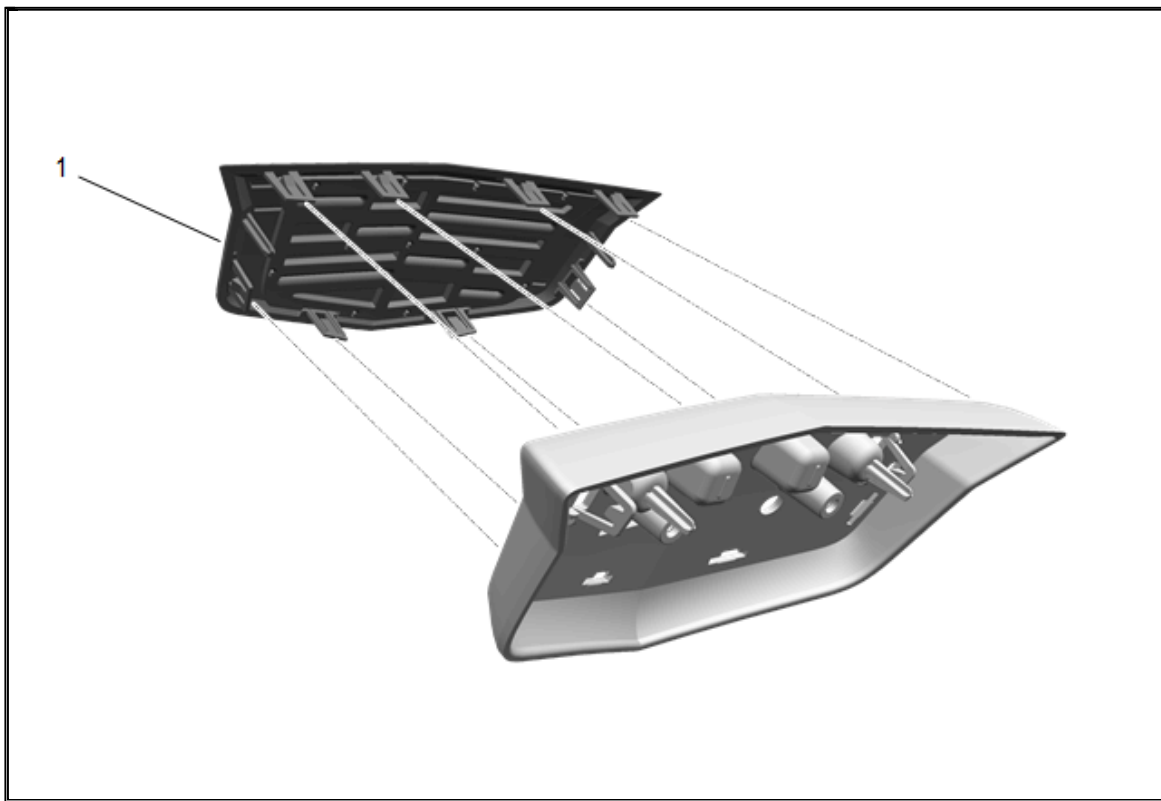

41. Using a suitable flat-bladed tool, release the locking tabs and remove the front grille emblem (1) from emblem adapter.

### **Install Front Emblem**

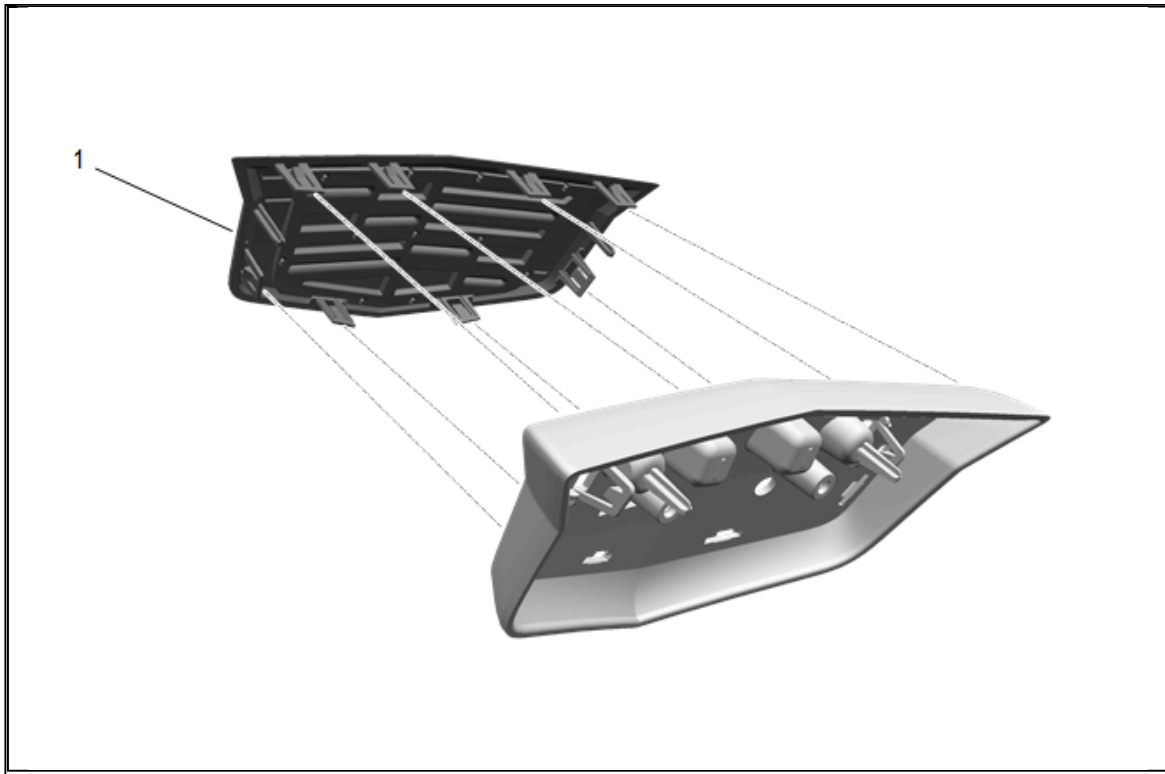

1. Accurately position the new front grille emblem (1) to the emblem adapter and engage the locking tabs.
2. Apply enough evenly distributed pressure to engage the locking tabs.

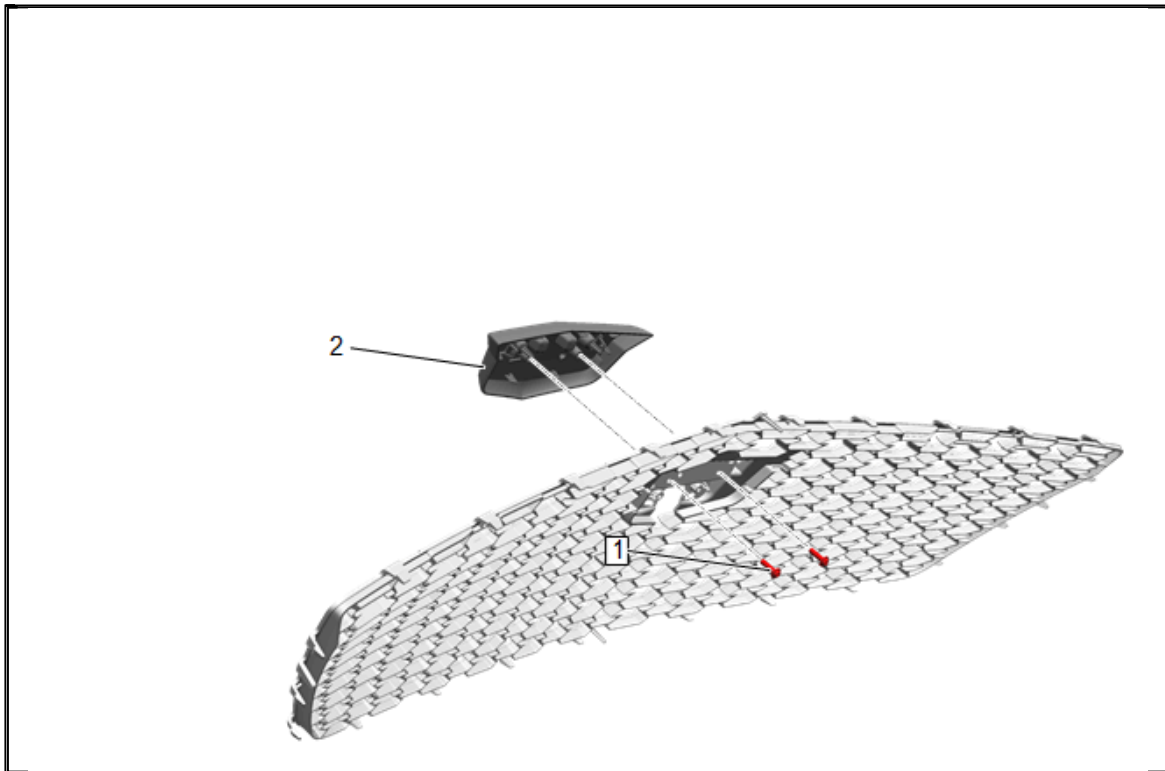

**Caution:** Use the correct fastener in the correct location. Replacement fasteners must be the correct part number for that application. Fasteners requiring replacement or fasteners requiring the use of thread locking compound or sealant are identified in the service procedure. Do not use paints, lubricants, or corrosion inhibitors on fasteners or fastener joint surfaces unless specified. These coatings affect fastener torque and joint clamping force and may damage the fastener. Use the correct tightening sequence and specifications when installing fasteners in order to avoid damage to parts and systems.

3. Position the front grille emblem adapter (2) from the front grille and engage the locking tabs.
4. Apply enough evenly distributed pressure to engage the locking tabs.
5. Install the bolts (1) qty:2 to the front grille emblem adapter. Tighten the bolts to 2.5 N.m (22 lb in).

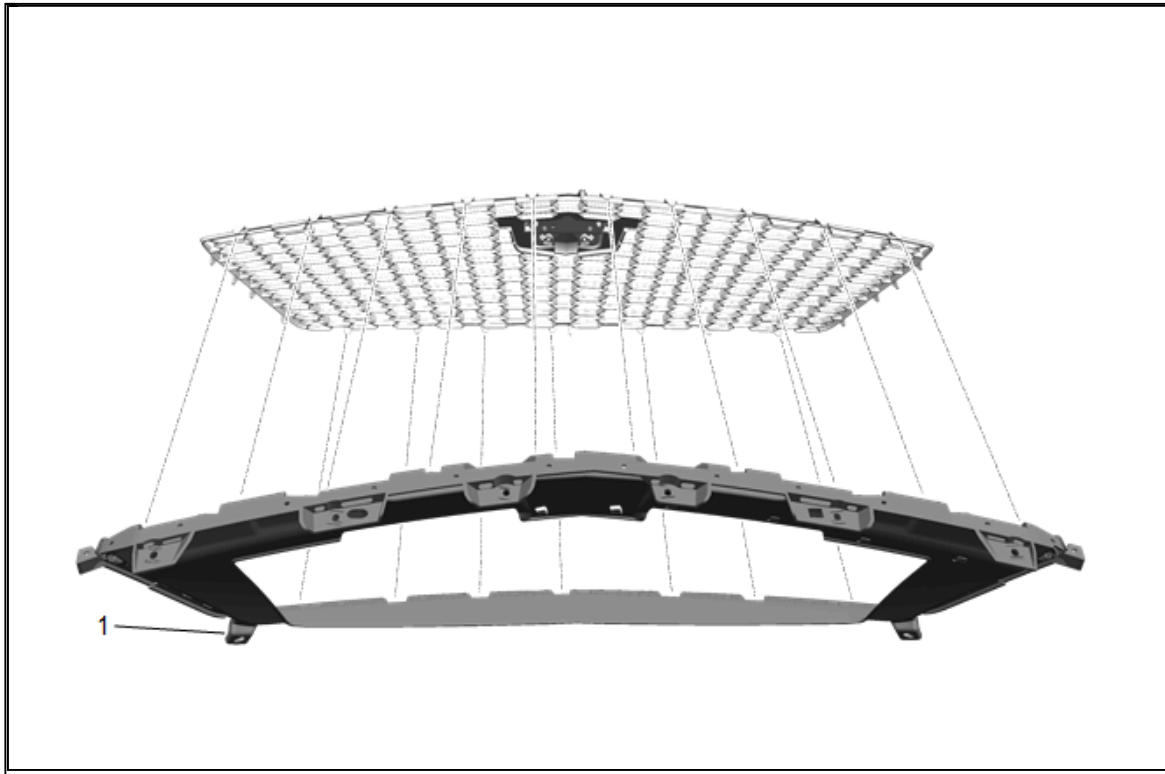

6. Position the front grille filler (1) to the front grille and engage the locking tabs.

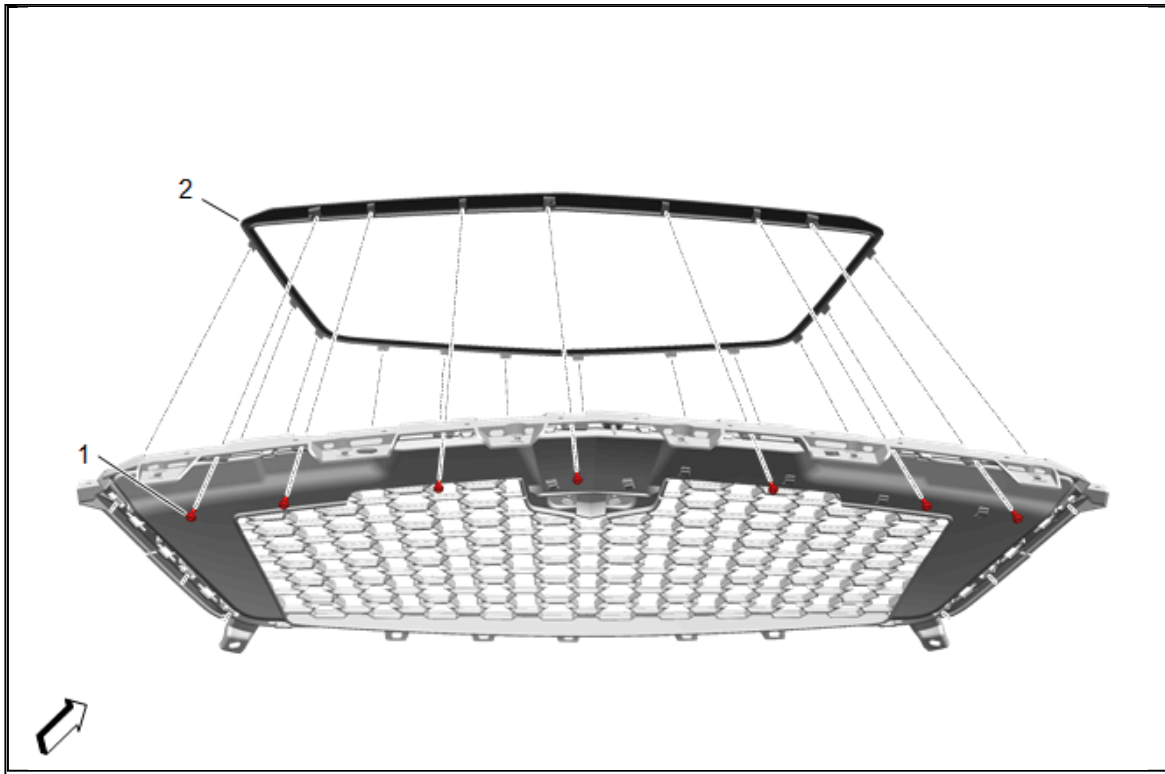

7. Position the front grille opening bezel (2) to the front grille and engage the locking tabs.
8. Install the bolts (1) qty:7 to the front grille. Tighten the bolts to 2.5 N.m (22 lb in).

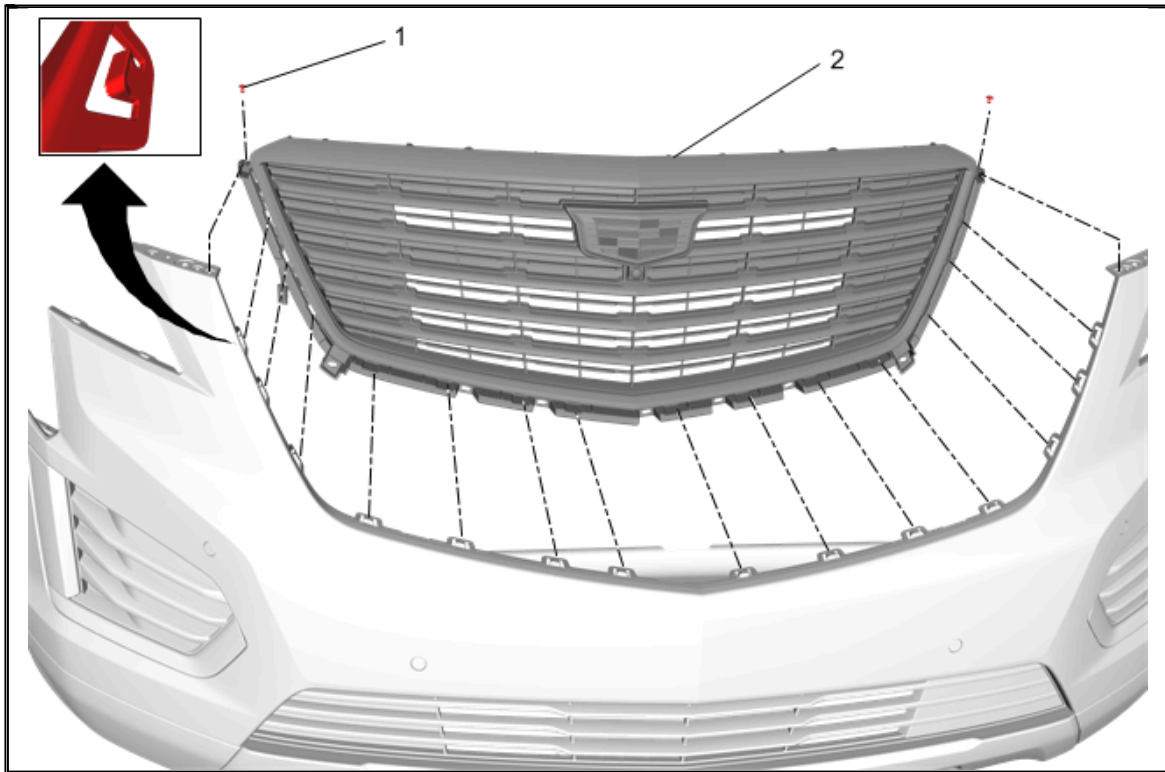

9. From the backside of the front bumper fascia install the front grille (2) to the front bumper fascia engaging the tabs to the grille.
10. Install two upper rivets (1) qty:2 to the front bumper upper fascia.

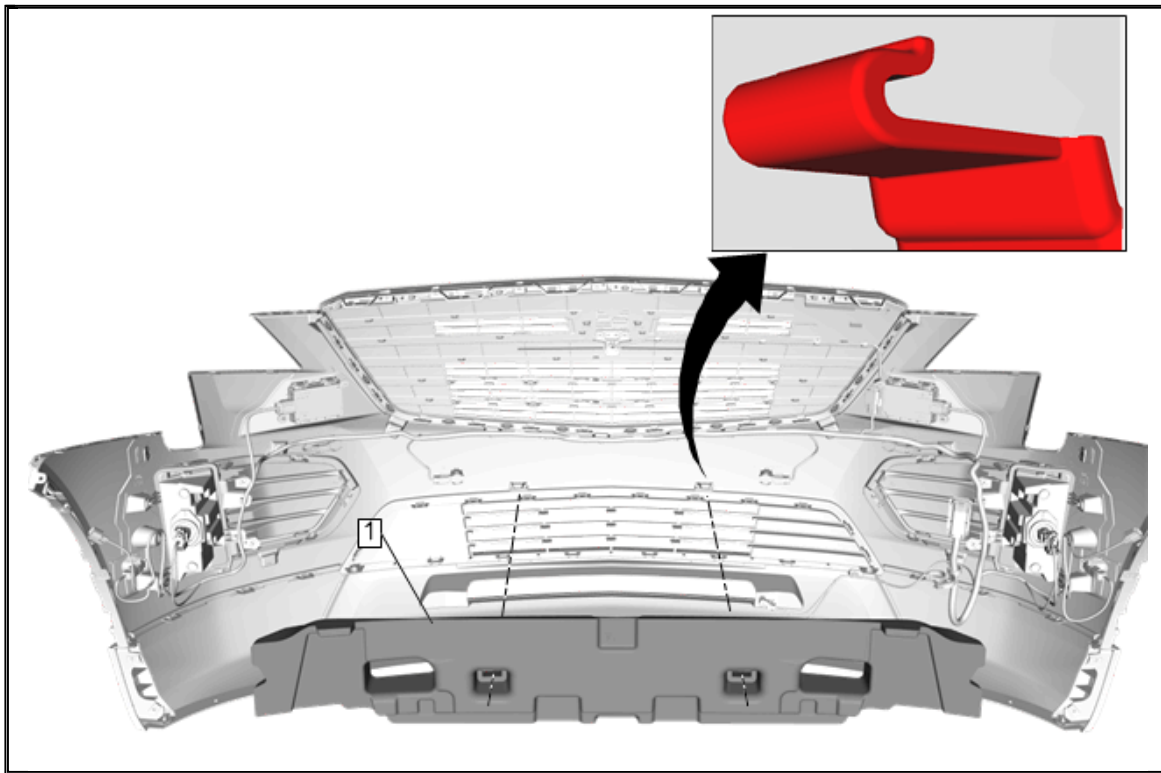

11. Position the front bumper fascia energy absorber (1) to the fascia and engage the 2 retainers.
12. Reposition the fascia wiring harness

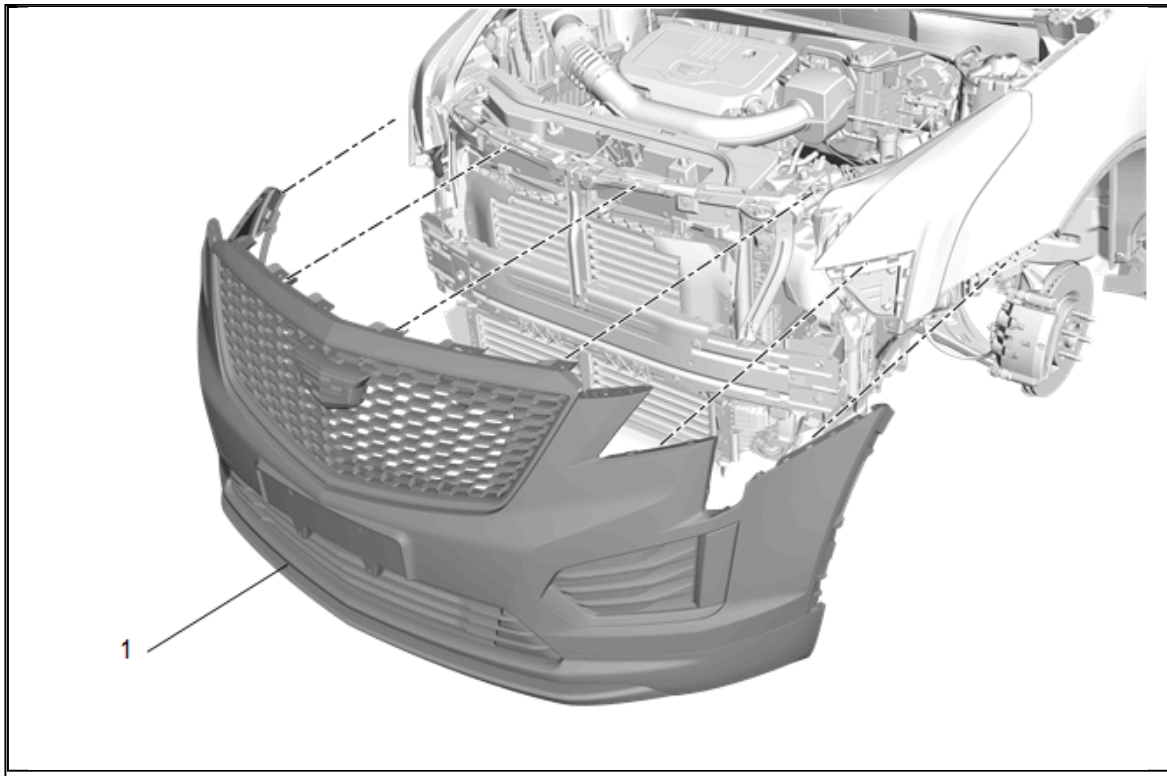

13. With the aid of an assistant, install the fascia. (1)

14. Connect the electrical connectors.

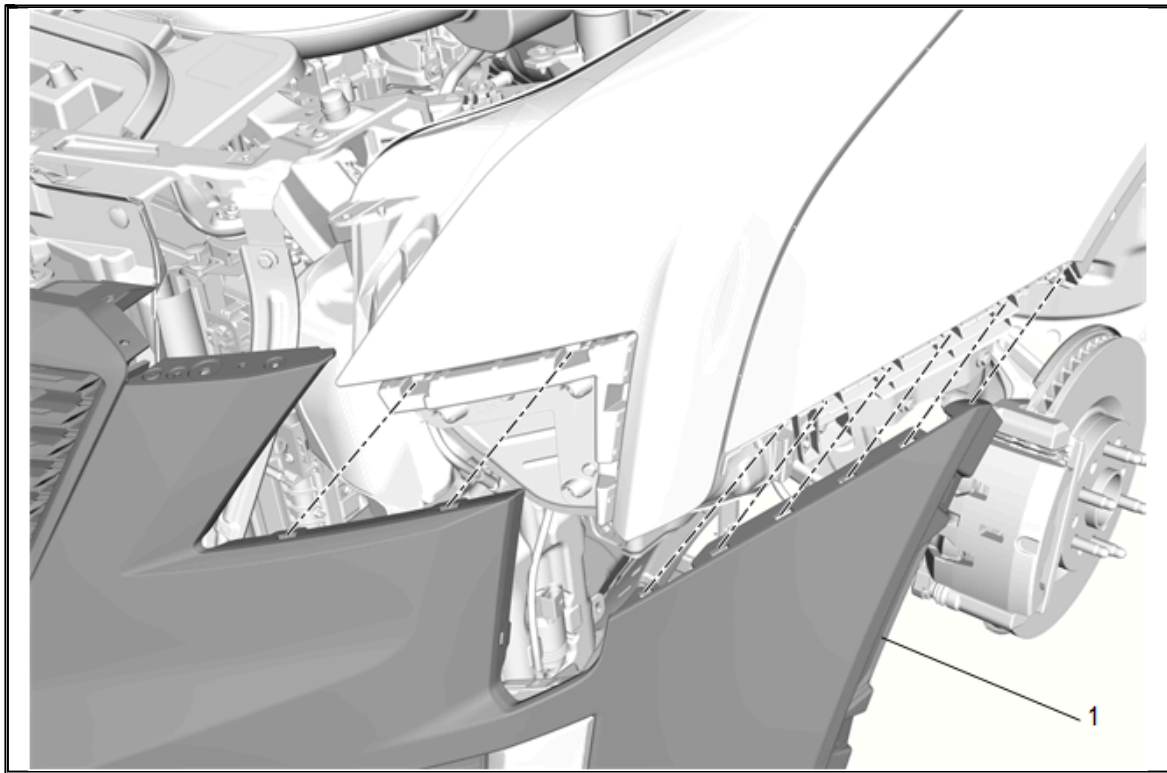

15. Install the tabs on the fascia (1) to the front bumper fascia guide on both sides.

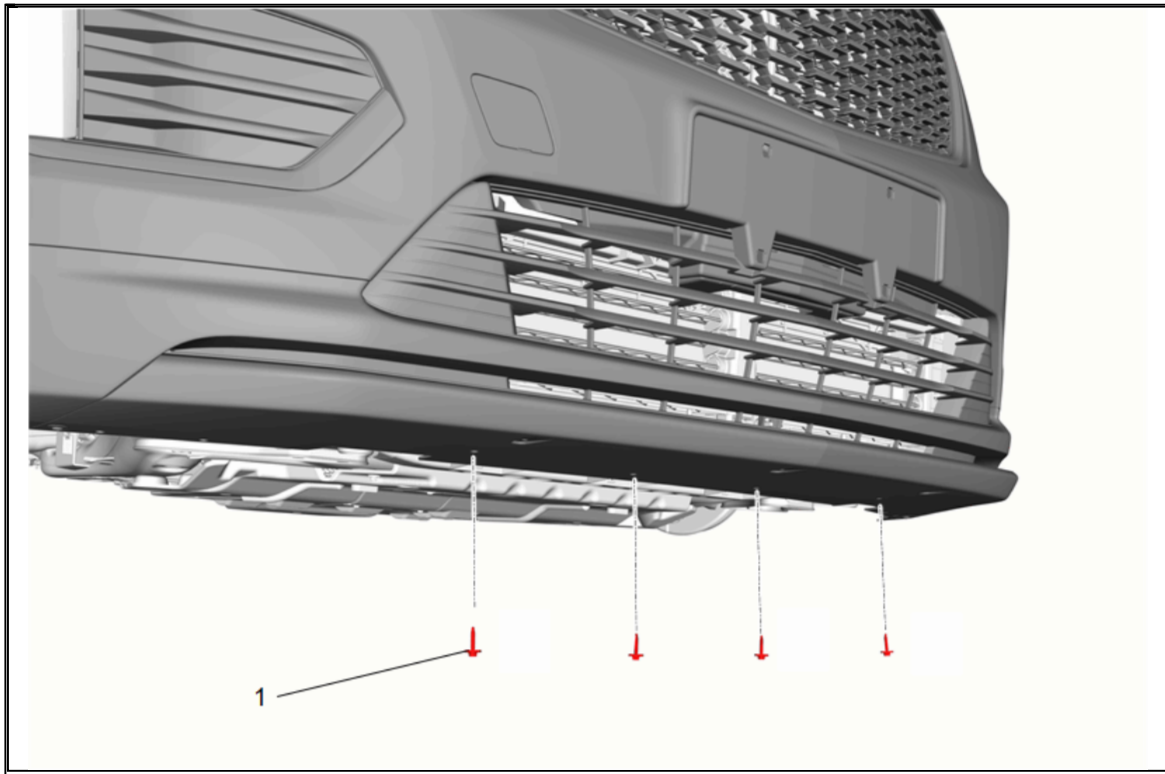

16. Front Bumper Fascia Bolt (1) » Install and tighten [7x] **2.5 N.m (22 lb in)**

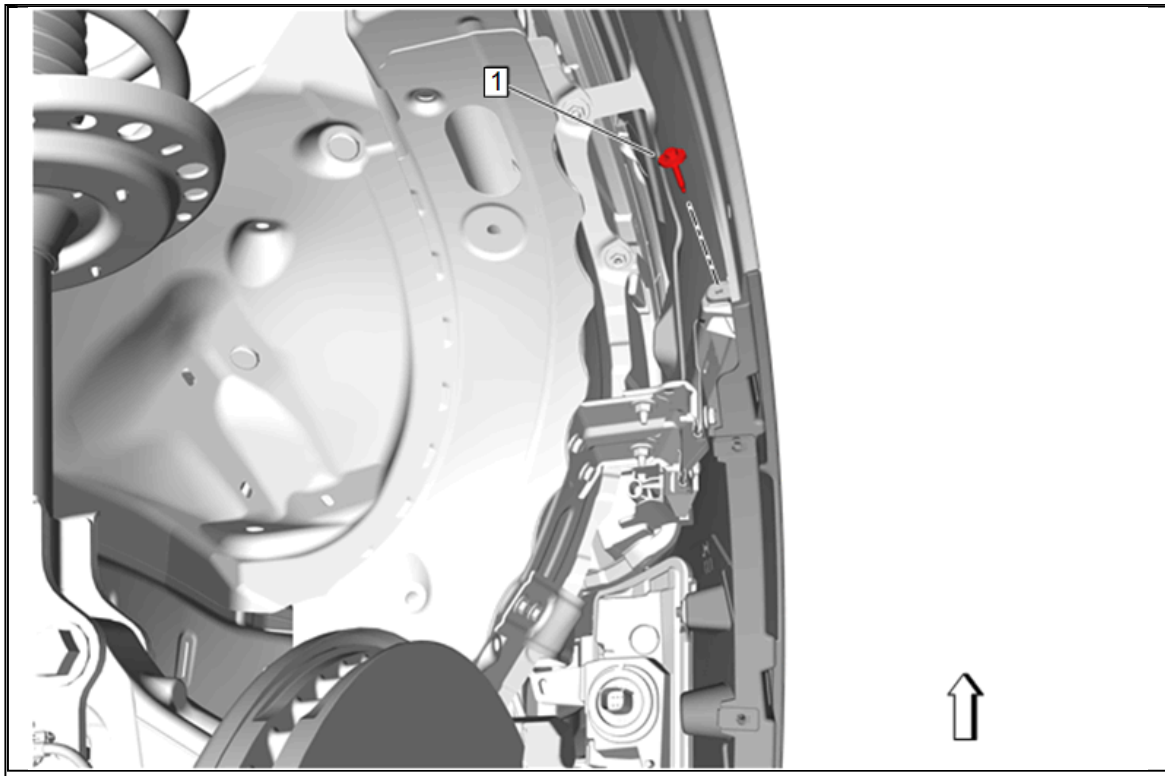

17. Reposition the right front wheelhouse liner and install the right side upper front bumper fascia bolt (1). Tighten the bolt to 2.5 N.m (22 lb in).

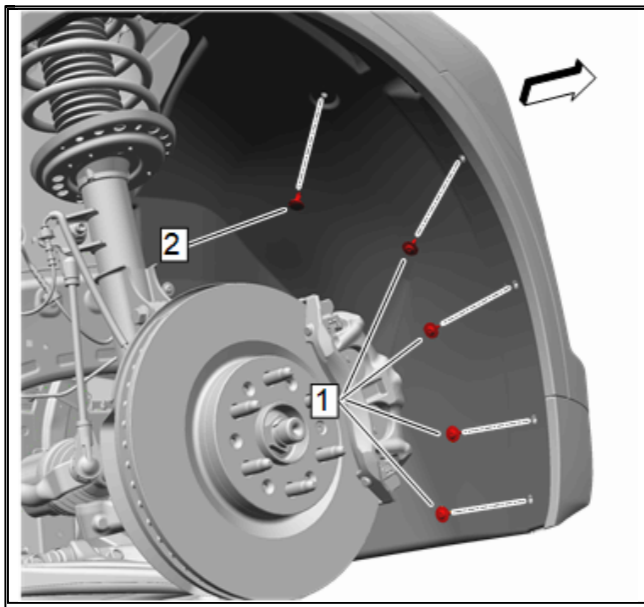

18. Install the right side wheelhouse liner push retainer (2).
19. Install the 4 right side wheelhouse liner bolts (1). Tighten the bolts to 2.5 N.m (22 lb in).

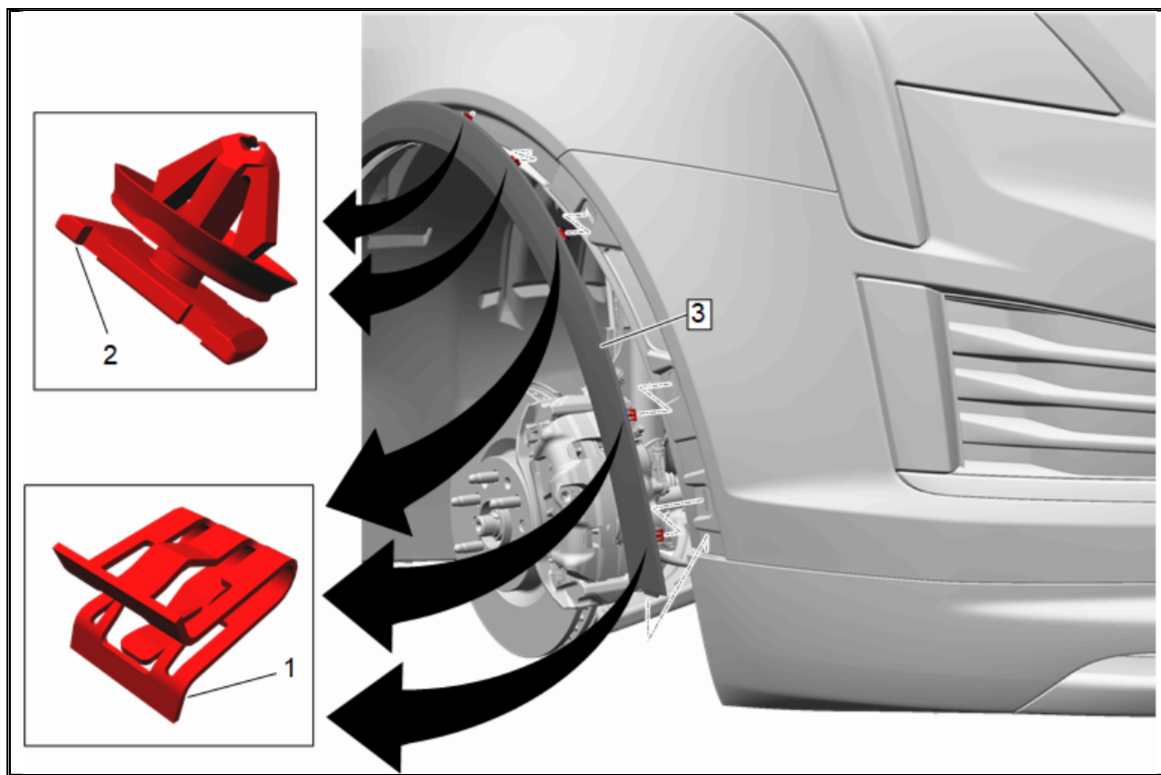

20. Engage the right wheel opening molding to the front bumper lower fascia.
21. Engage the 3 clips (1) and 2 retainers (2) around the front bumper fascia and the top front fender.
22. Remove masking tape around the edge of the right front wheel opening molding.
23. Remove any remaining adhesive residue.

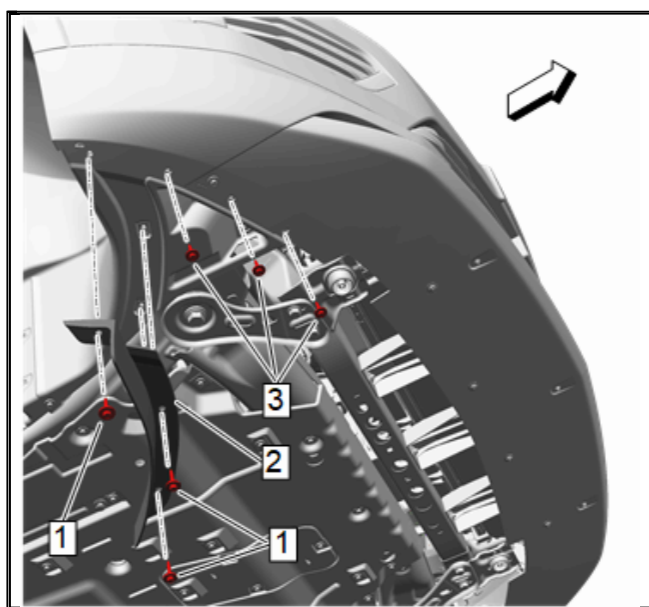

24. Install the 3 right side front lower fascia bolts (3).
25. Install the right front air deflector (2) and the deflector bolts (1). Tighten the bolts to 2.5 N.m (22 lb in).

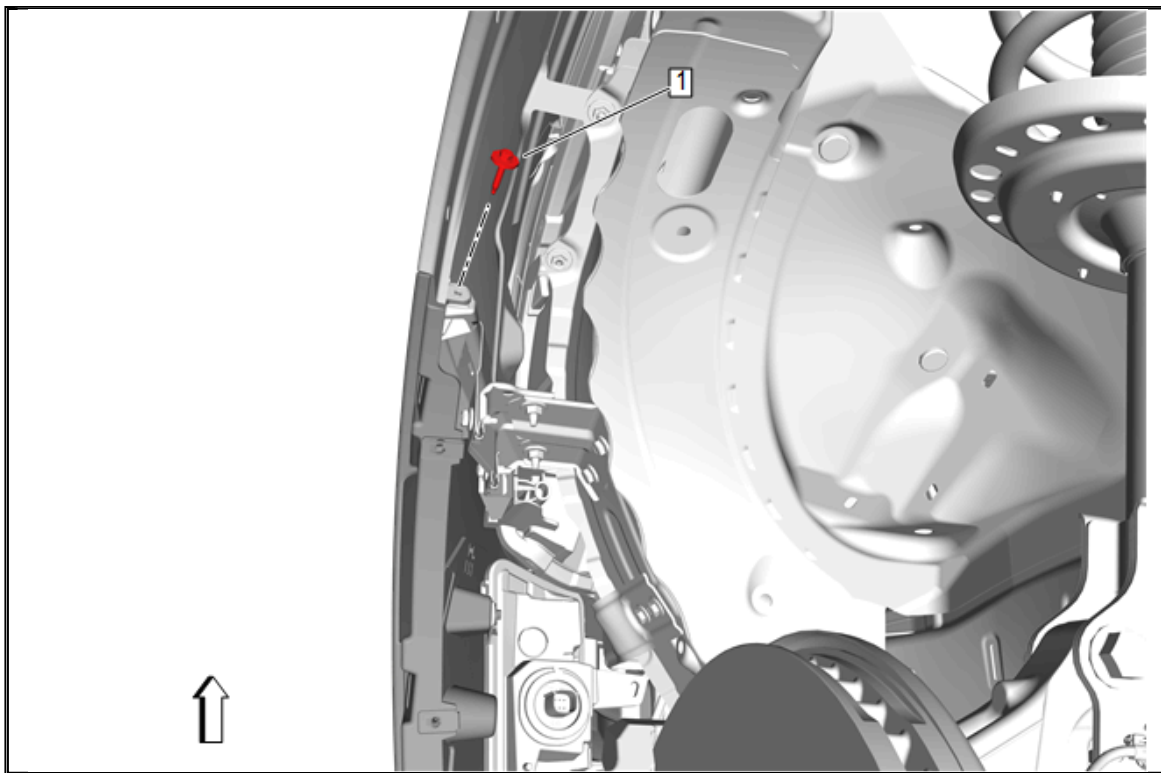

26. Reposition the left front wheelhouse liner and install the left side upper front bumper fascia bolt (1). Tighten the bolt to 2.5 N.m (22 lb in).

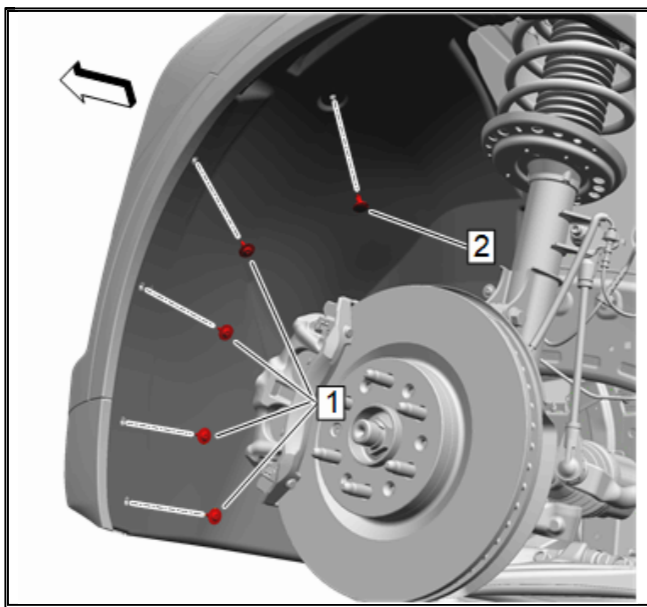

27. Install the left side wheelhouse liner push retainer (2).
28. Install the 4 left side wheelhouse liner bolts (1). Tighten the bolts to 2.5 N.m (22 lb in).

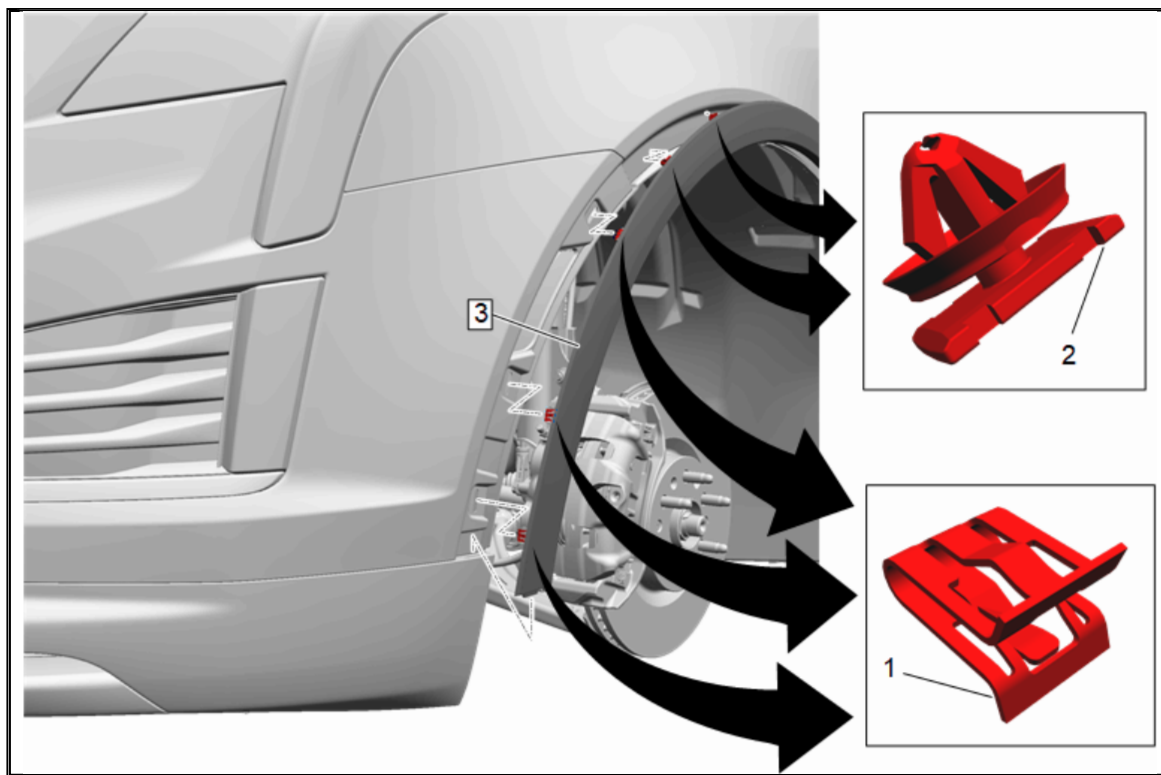

29. Engage the left wheel opening molding to the front bumper lower fascia.
30. Engage the 3 clips (1) and 2 retainers (2) around the front bumper fascia and the top front fender.
31. Remove masking tape around the edge of the left front wheel opening molding.
32. Remove any remaining adhesive residue.

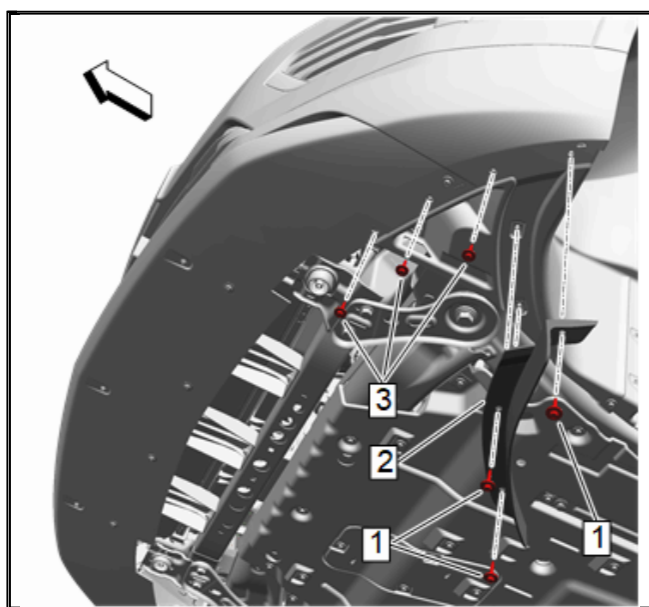

33. Install the 3 left side front lower fascia bolts (3).
34. Install the left front air deflector (2) and the deflector bolts (1). Tighten the bolts to 2.5 N.m (22 lb in).

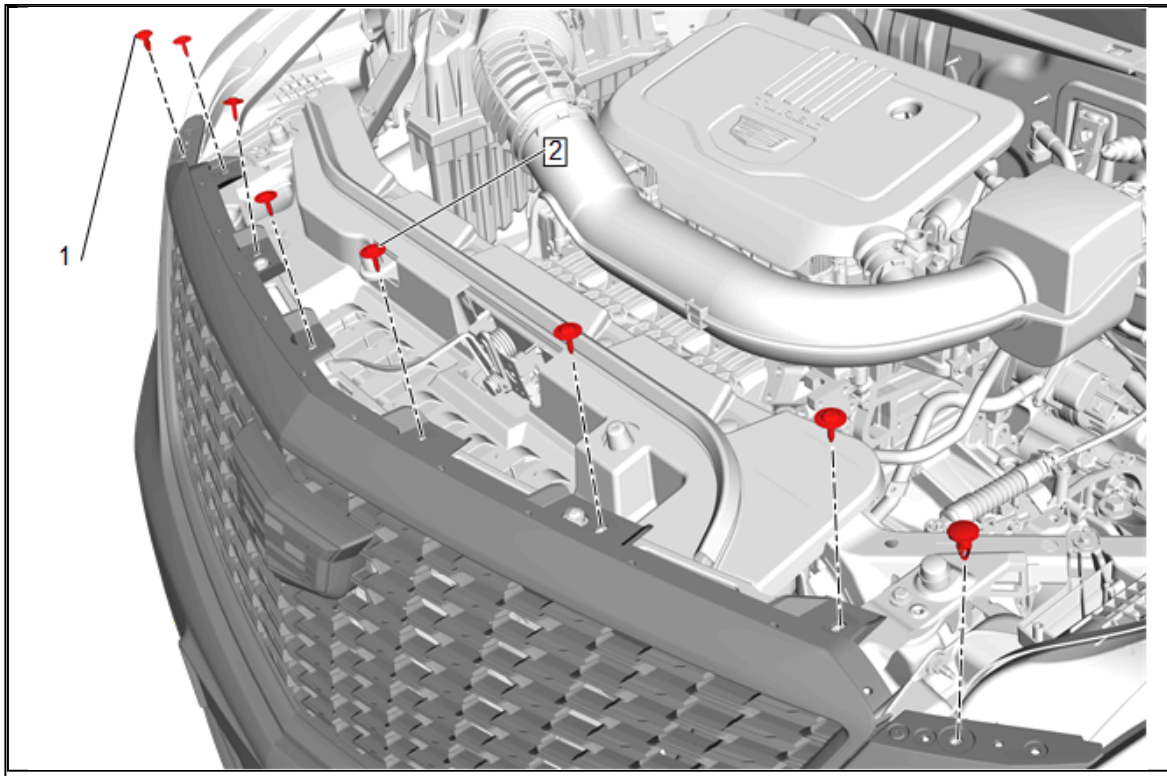

35. Front Bumper Fascia Bolt (2) » Install and tighten [6x] **2.5 N.m (22 lb in)**

36. Front Bumper Fascia Retainer (1) » Install [2x]

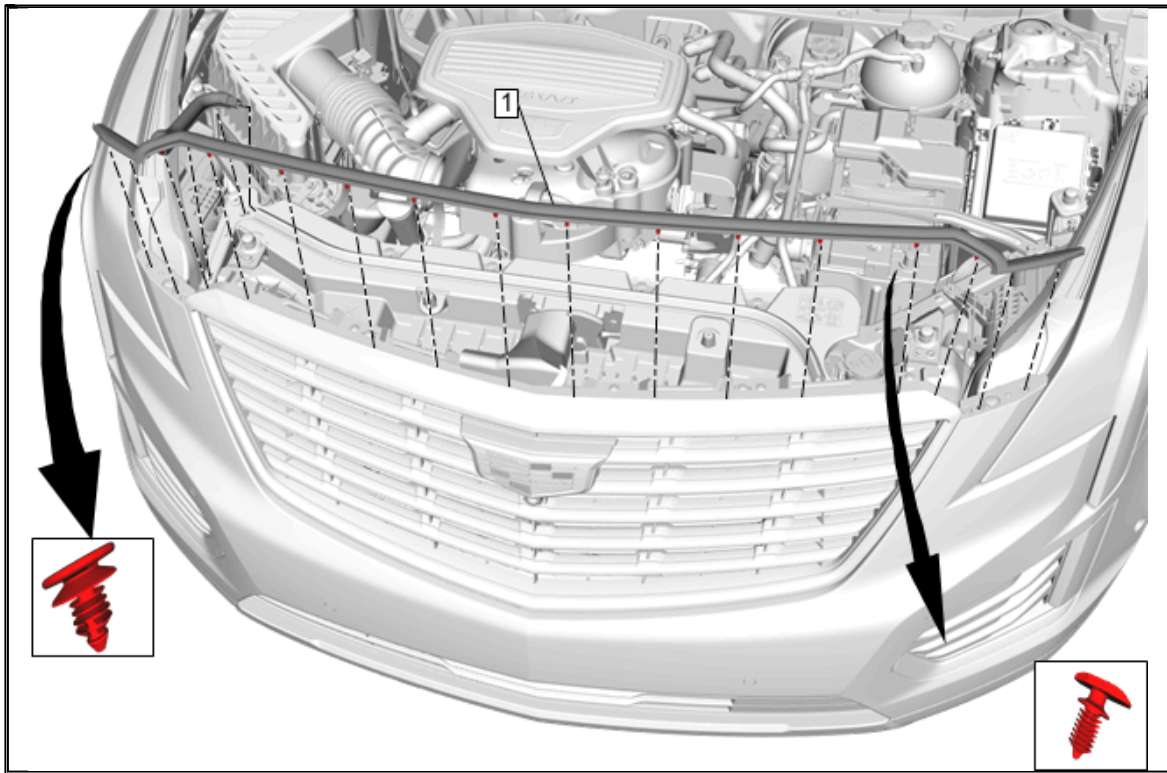

37. Install the hood front edge weather-strip (1) to the front grille and engage the integral retainers.
38. { If equipped } Perform the night vision camera module learn. Refer to [Night Vision Camera Control Module Learn](#) in Vehicle Service Manual.
39. Ensure all electrical connections are intact, test any front lighting to confirm it is functioning.
40. Remove the support and lower the vehicle.

### Rear Emblem Procedure

1. Turn off vehicle.

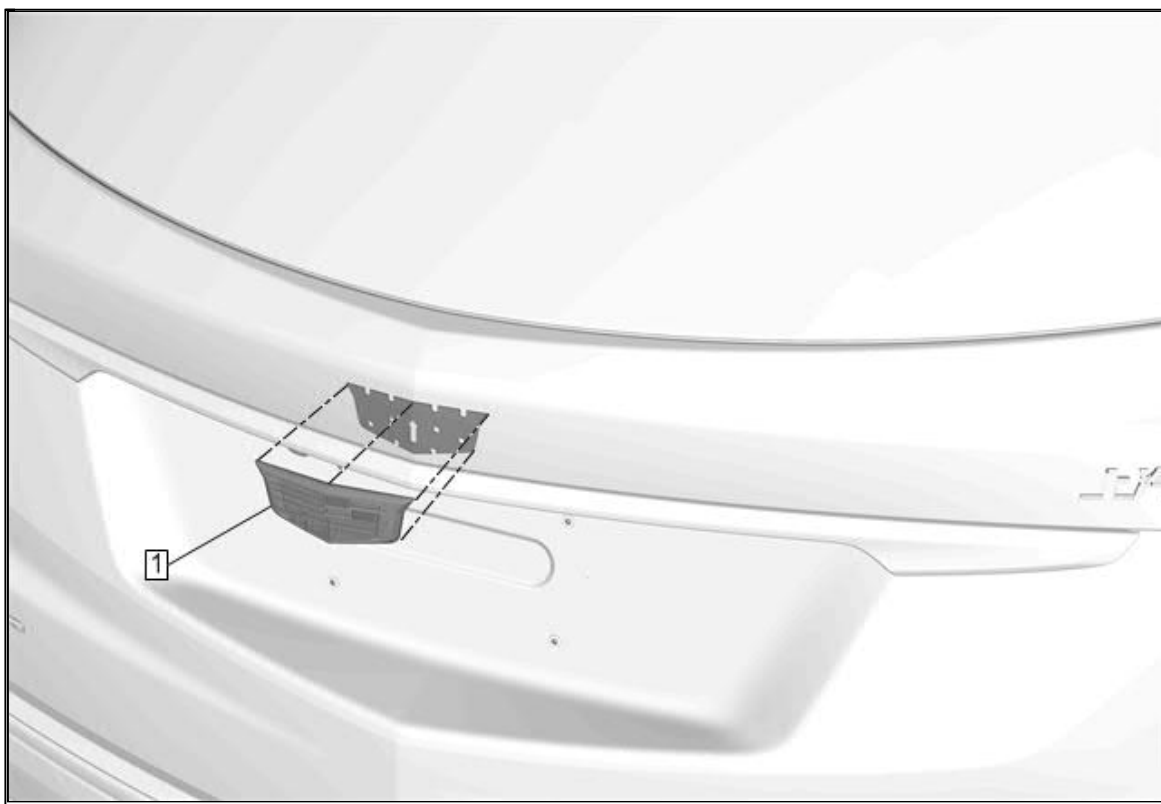

**Caution:** Applying excessive heat to the emblem/nameplate may damage the paint and surrounding panel surfaces during removal. Heat temperature SHOULD NOT exceed 79°C (175°F).

**Caution:** Use a plastic, flat-bladed tool to prevent paint damage when removing an emblem/name plate.

2. The part and surface should be 21°C (70°F) prior to installation. The vehicle should remain 21°C (70°F) for one hour after assembly to allow adhesive to develop sufficient bond strength.
3. Use a heat gun or equivalent to remove the old emblem (1).
4. 3. Clean the area with a 50/50 mixture by volume of isopropyl alcohol and clean drinkable water to remove any left over adhesive residue.
5. Dry the area thoroughly with a clean dry cotton cloth prior to installing the new emblem (1).
6. When removing protective liners from the adhesive tape, be careful not to touch tape with hands and do not allow tape to come in contact with dirt or any foreign matter prior to adhesion.

7. Using the palm of the hand or an applicable roller with approximately 10 lbs of pressure, wet out the emblem/name plate to the liftgate to ensure full adhesion of the emblem/nameplate is made.

# Cadillac XT6 | Document ID: 5554552

## Body Emblem Package Installation (Instruction ID: 84675915)

### Installation Instructions Part Number

84675915

### Kit Contents

Qty	Description
1	Emblem Assembly – Front
1	Emblem Assembly – Liftgate
1	Alcohol Wipe
1	Installation Instructions

### Tools Required

Flat bladed plastic trim tool

Masking tape

### Procedure

#### Remove Front Emblem

1. Read all instructions before performing procedure.
2. Inspect kit to verify all parts are included.
3. Turn off the vehicle.
4. Raise and support the vehicle. Refer to [Lifting and Jacking the Vehicle](#) in Vehicle Service Manual.
5. Remove both front tires. Refer to [Tire and Wheel Removal and Installation](#) in Vehicle Service Manual.
6. Open hood.

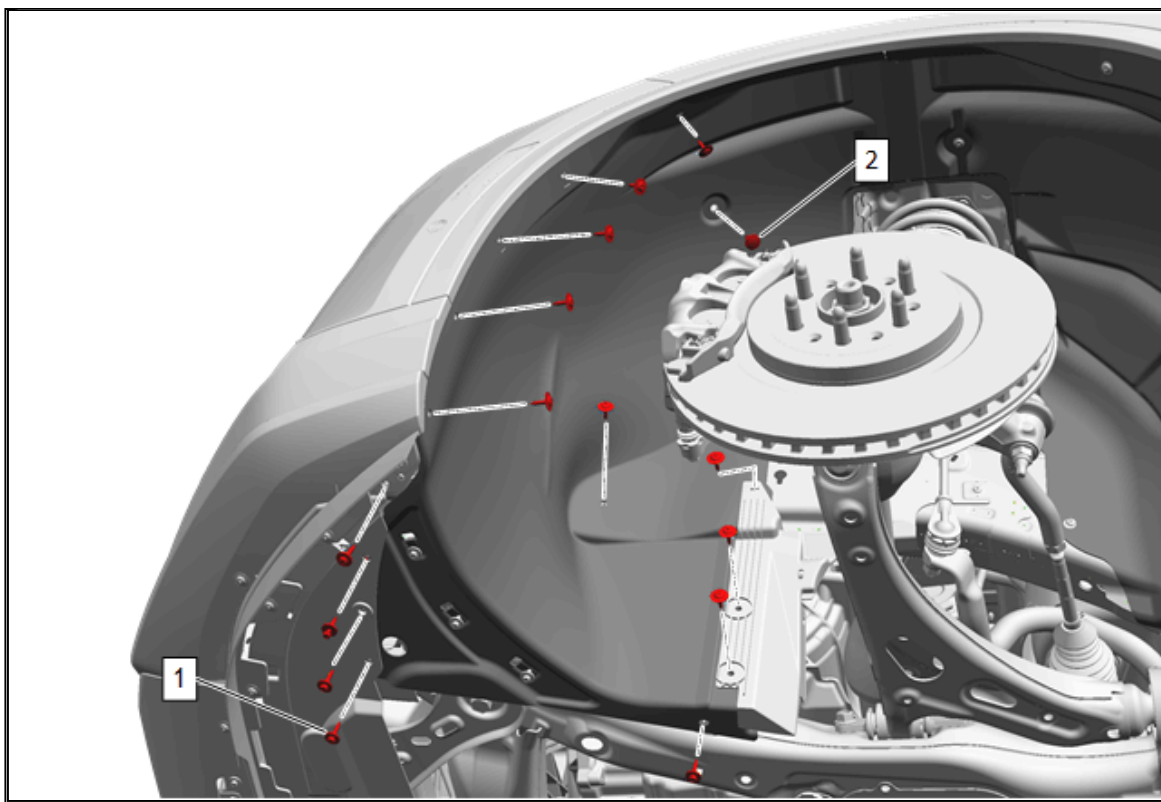

**Note:** Complete removal of front wheelhouse liner is not required.

7. Remove the 14 left side front wheelhouse liner bolts (1).
8. Remove the left side front wheelhouse liner retainer (2).

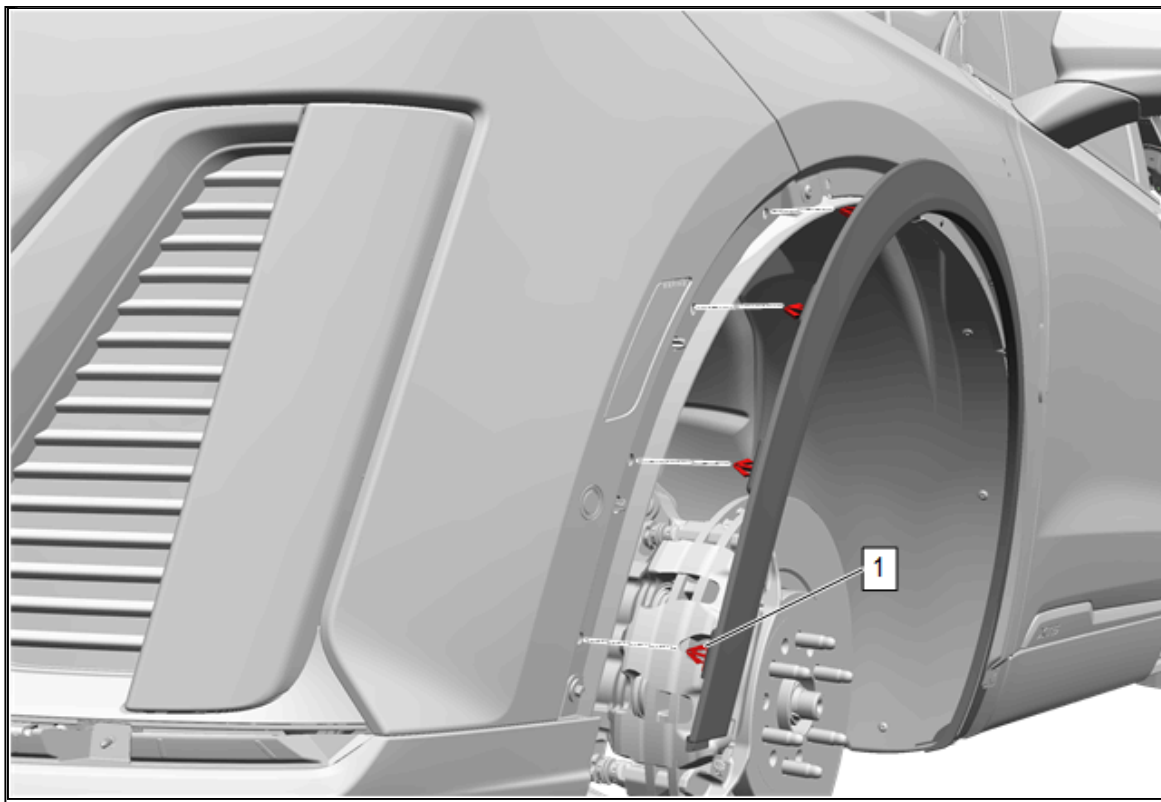

**Note:** Complete removal of front wheel opening molding is not required.

9. Apply two layers of masking tape around the top edge of the left front wheel opening molding to prevent any paint surface damage.
10. Using a suitable flat bladed plastic tool, release the front 4 retainers (1) from the left side front wheel opening molding.
11. Pull upward to release the left front wheel opening molding (3) from the front bumper lower fascia.

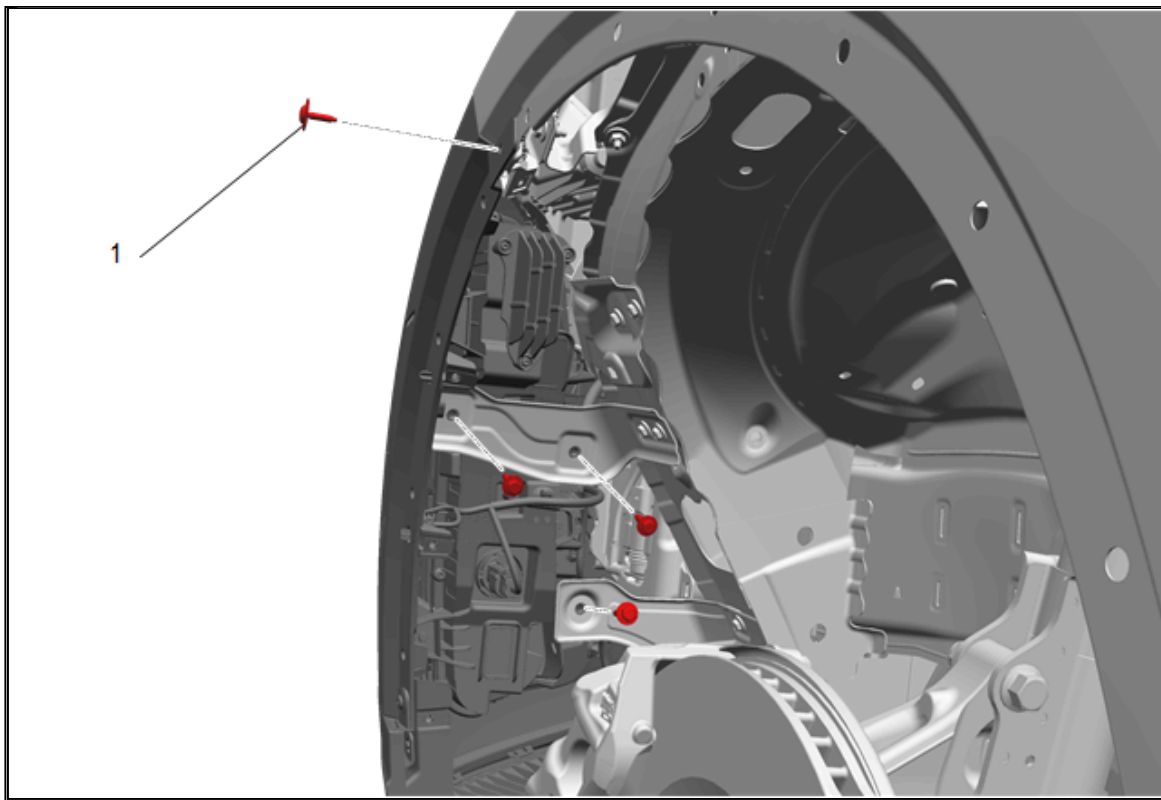

12. Reposition the wheelhouse liner and remove the 4 front bumper fascia bolts (1) from the left side.

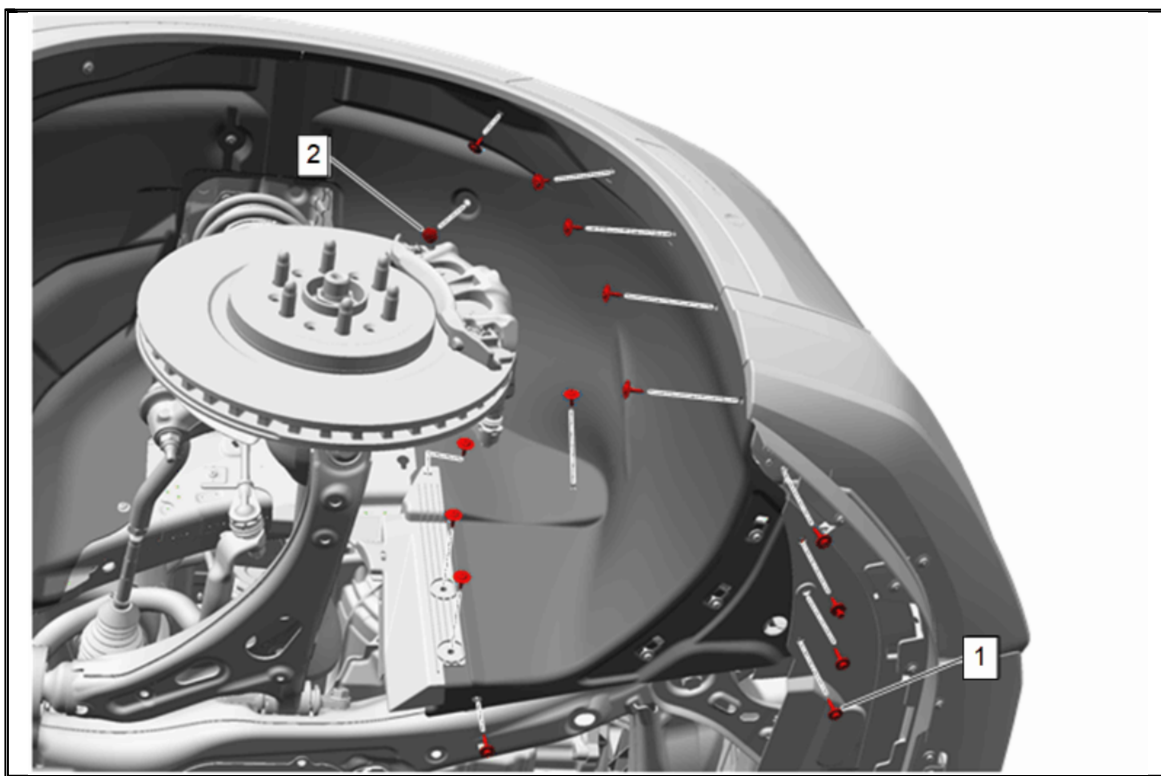

**Note:** Complete removal of front wheelhouse liner is not required.

13. Remove the 14 right side front wheelhouse liner bolts (1).
14. Remove the right side front wheelhouse liner retainer (2).

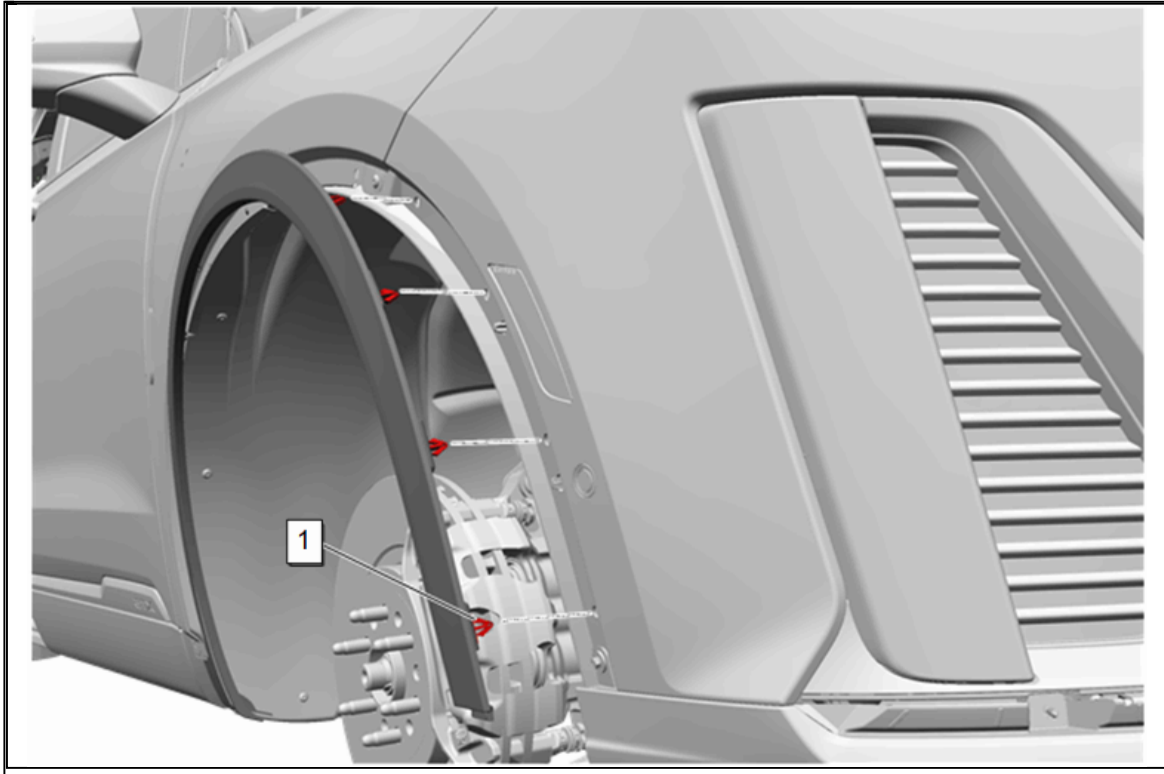

**Note:** Complete removal of front wheel opening molding is not required.

15. Apply two layers of masking tape around the top edge of the right front wheel opening molding to prevent any paint surface damage.
16. Using a suitable flat bladed plastic tool, release the front 4 retainers (1) from the right side front wheel opening molding.
17. Pull upward to release the right front wheel opening molding (3) from the front bumper lower fascia.

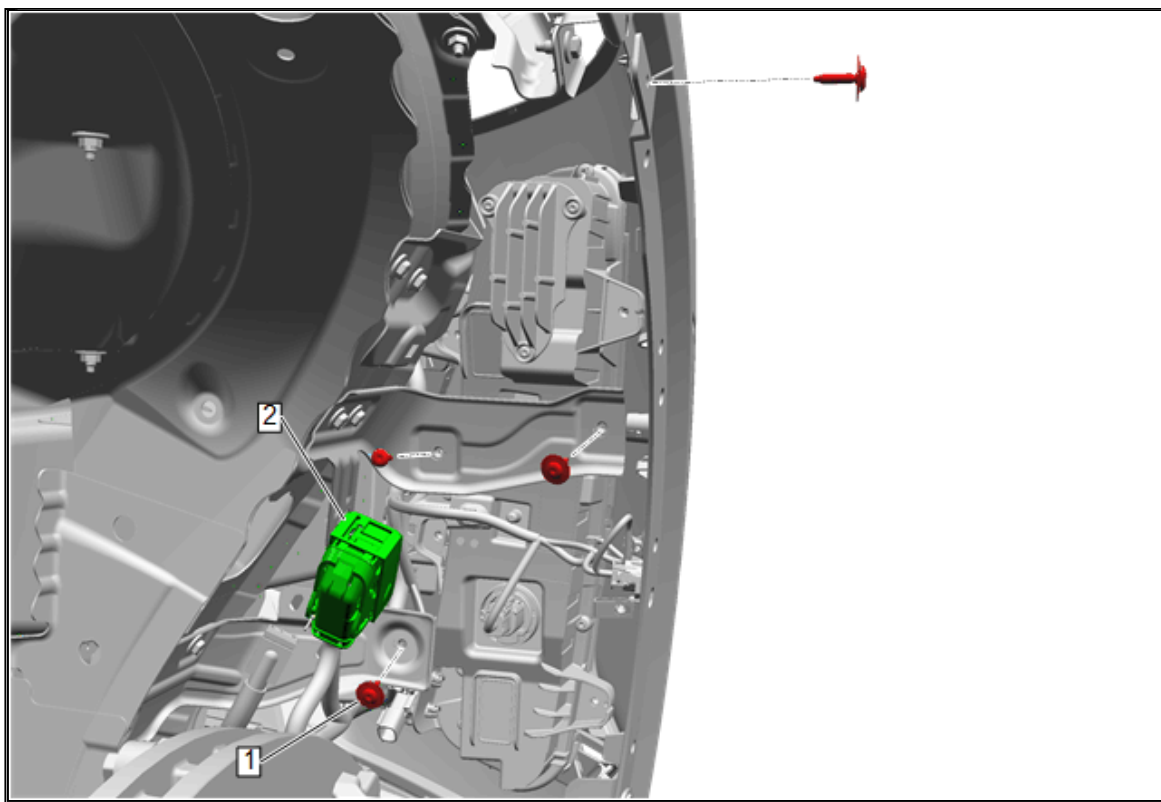

18. Remove the 4 front bumper fascia bolts (1) from the right side.
19. Disconnect the electrical connector. - Right Side (2)

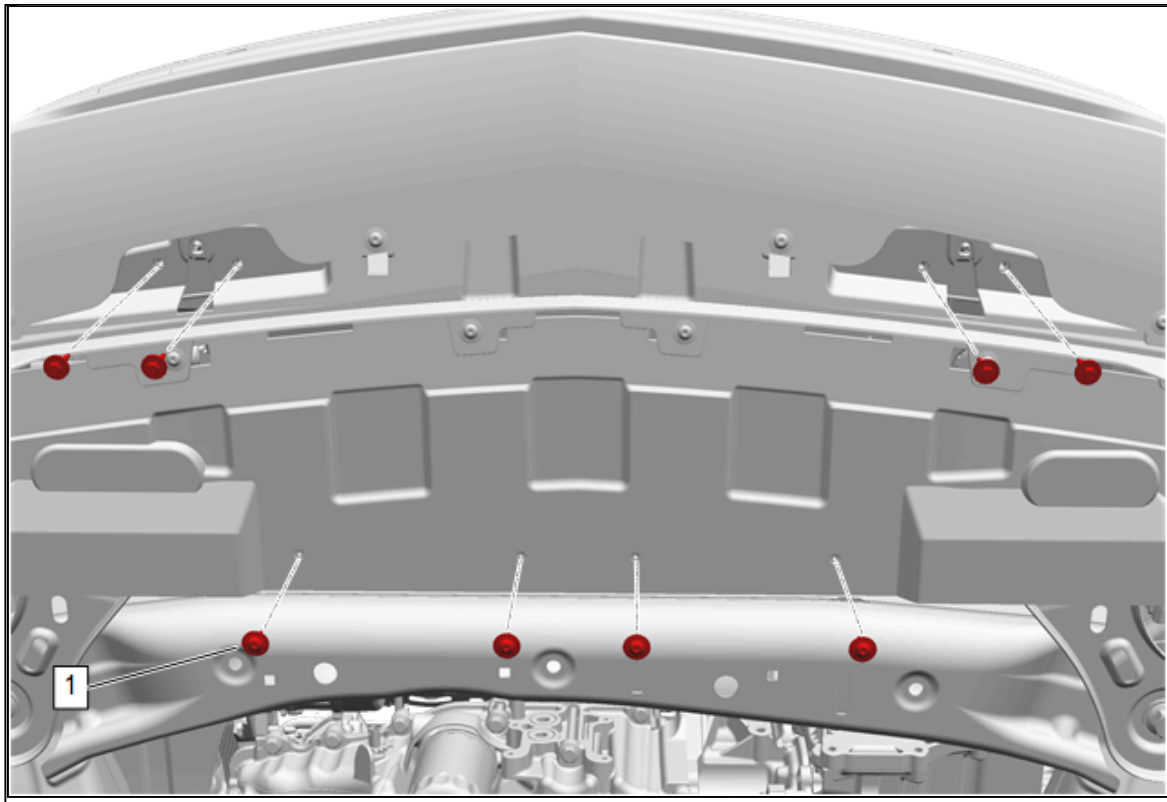

20. Front Bumper Fascia Bolt (1) » Remove [8x]

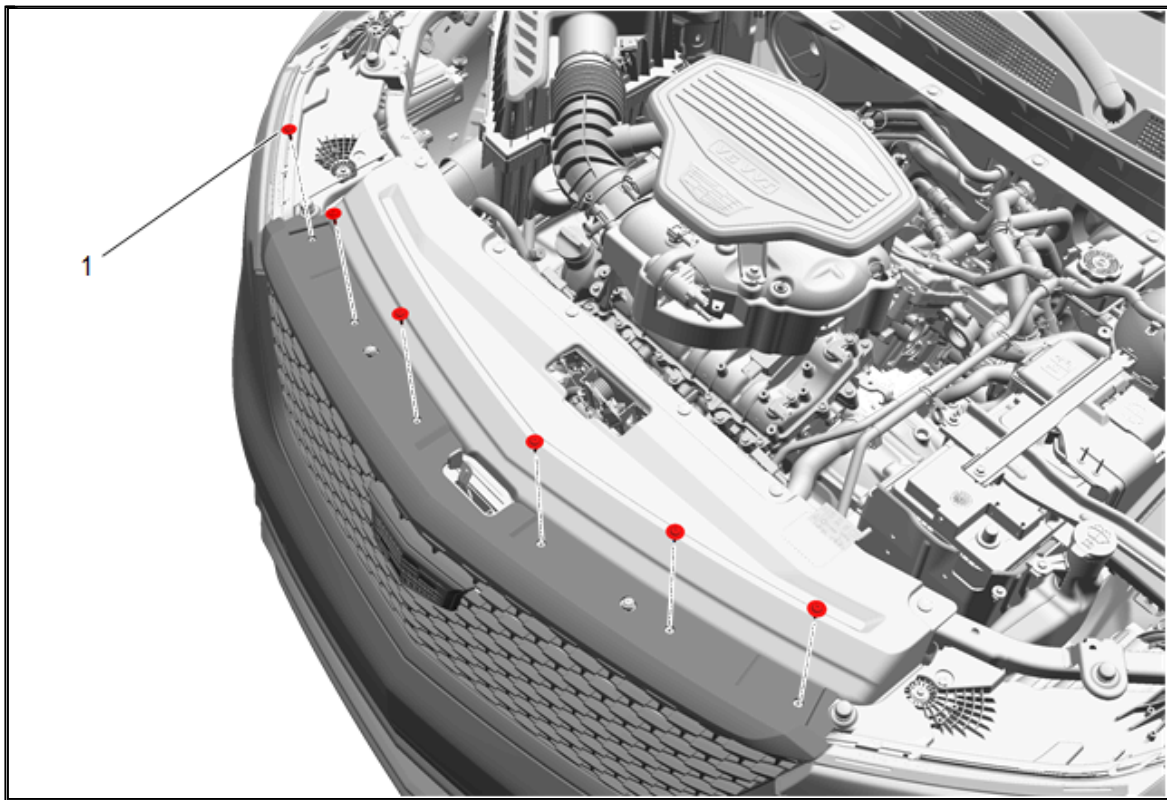

21. Front Bumper Fascia Bolt (1) » Remove [6x]

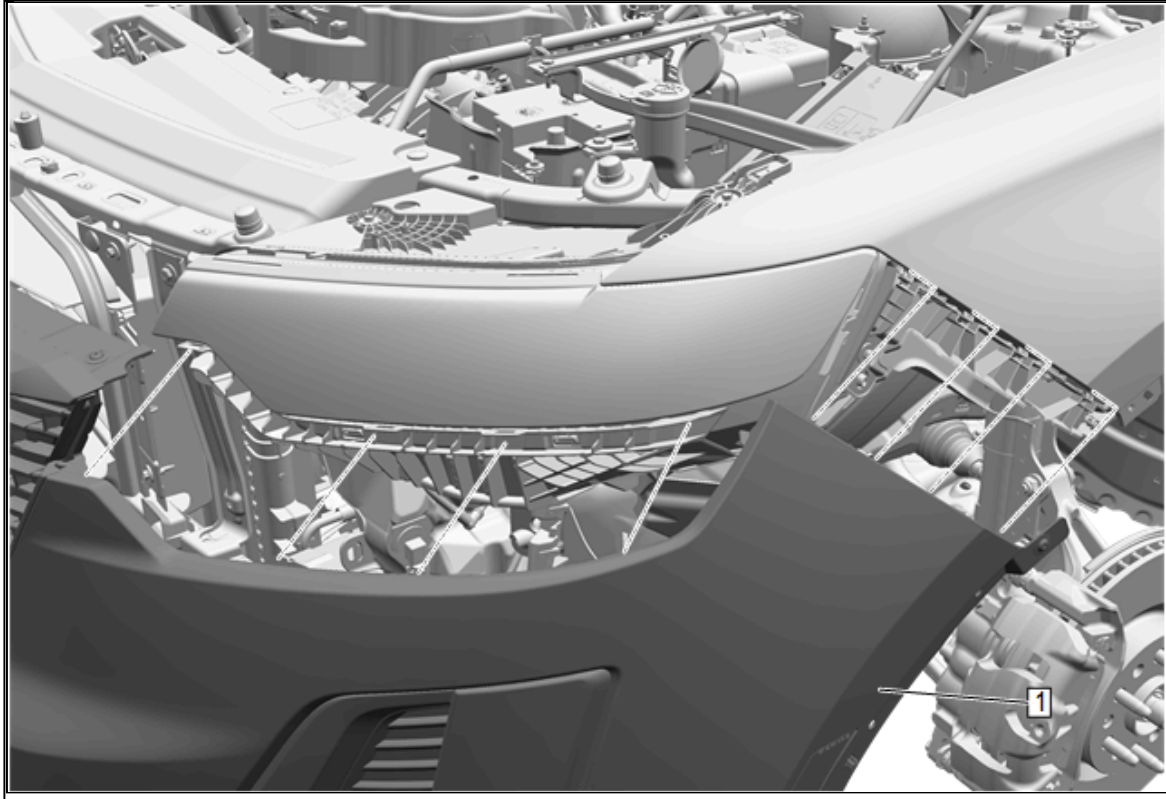

22. Carefully push a small nylon wedge between the fascia (1) and the fascia guide on the left side. Insert a small flat-bladed tool into the fascia slot and depress the snaps one at a time and pull on the fascia at the same time to gradually remove the fascia.
23. Release the tabs on the fascia (1) from the headlamp.

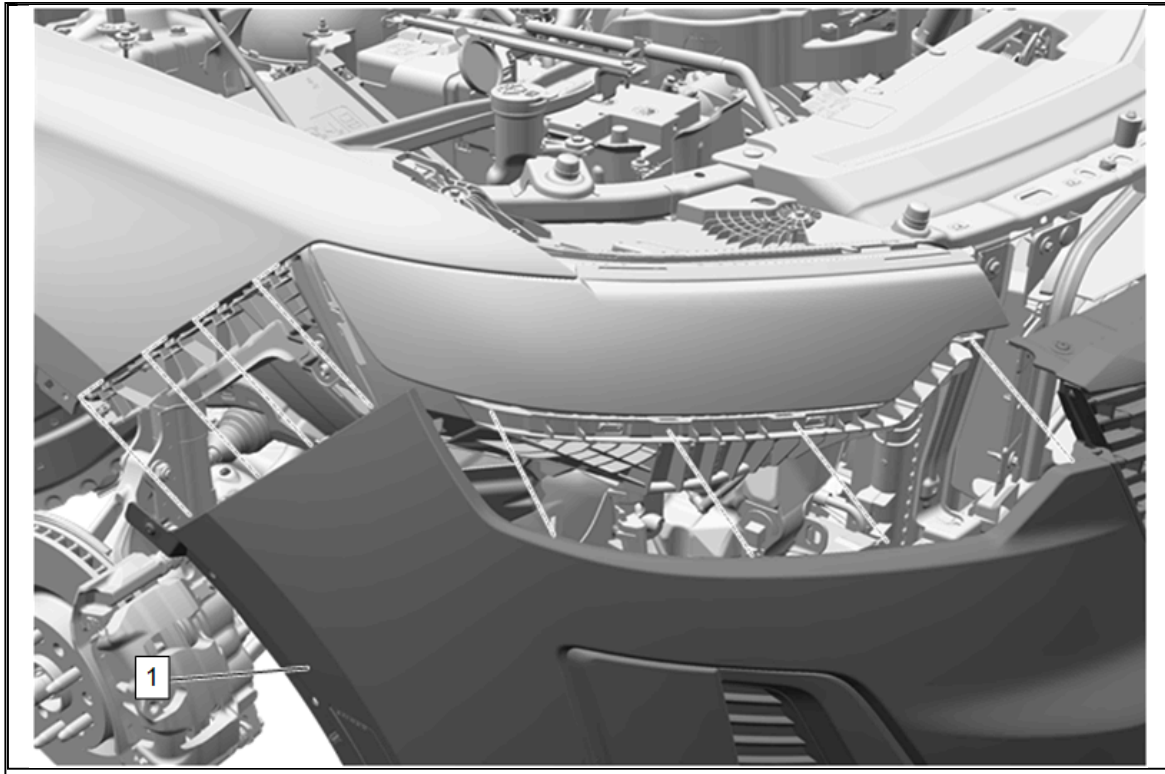

24. Carefully push a small nylon wedge between the fascia (1) and the fascia guide on the right side. Insert a small flat-bladed tool into the fascia slot and depress the snaps one at a time and pull on the fascia at the same time to gradually remove the fascia.
25. Release the tabs on the fascia (1) from the headlamp.

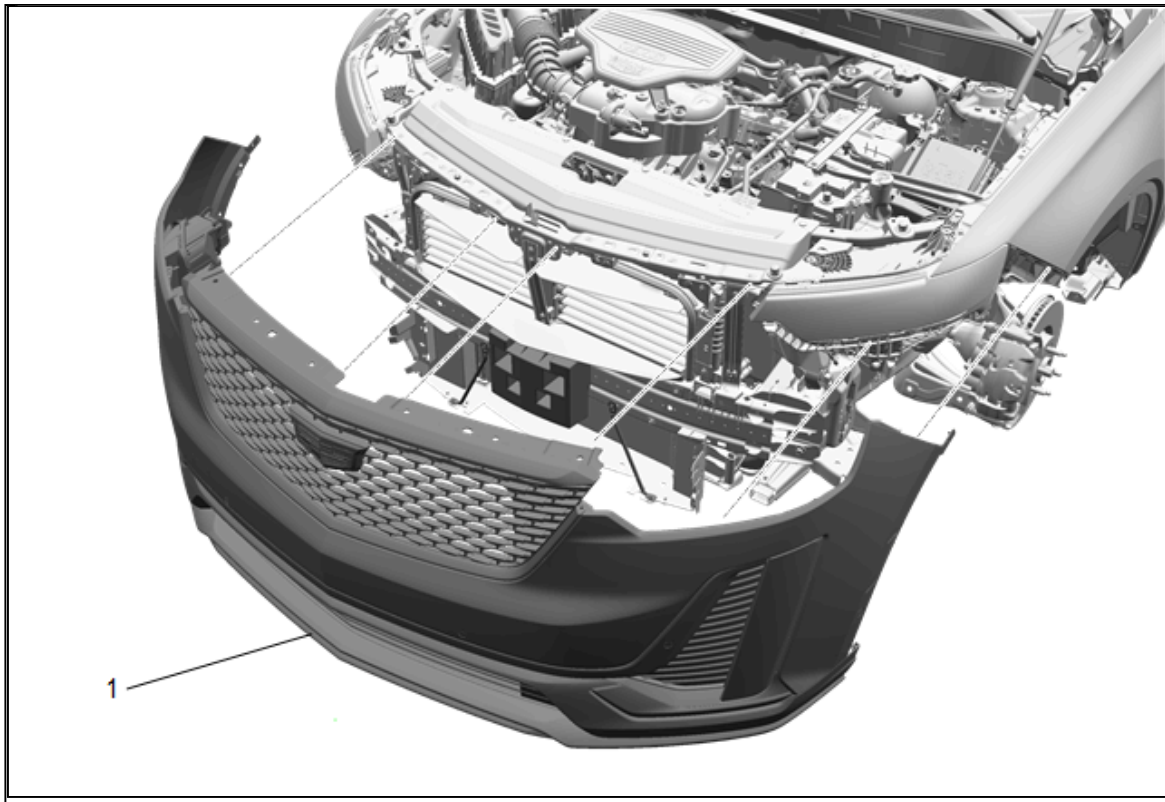

26. With the aid of an assistant, remove the fascia. (1)
27. Disconnect all electrical connectors.

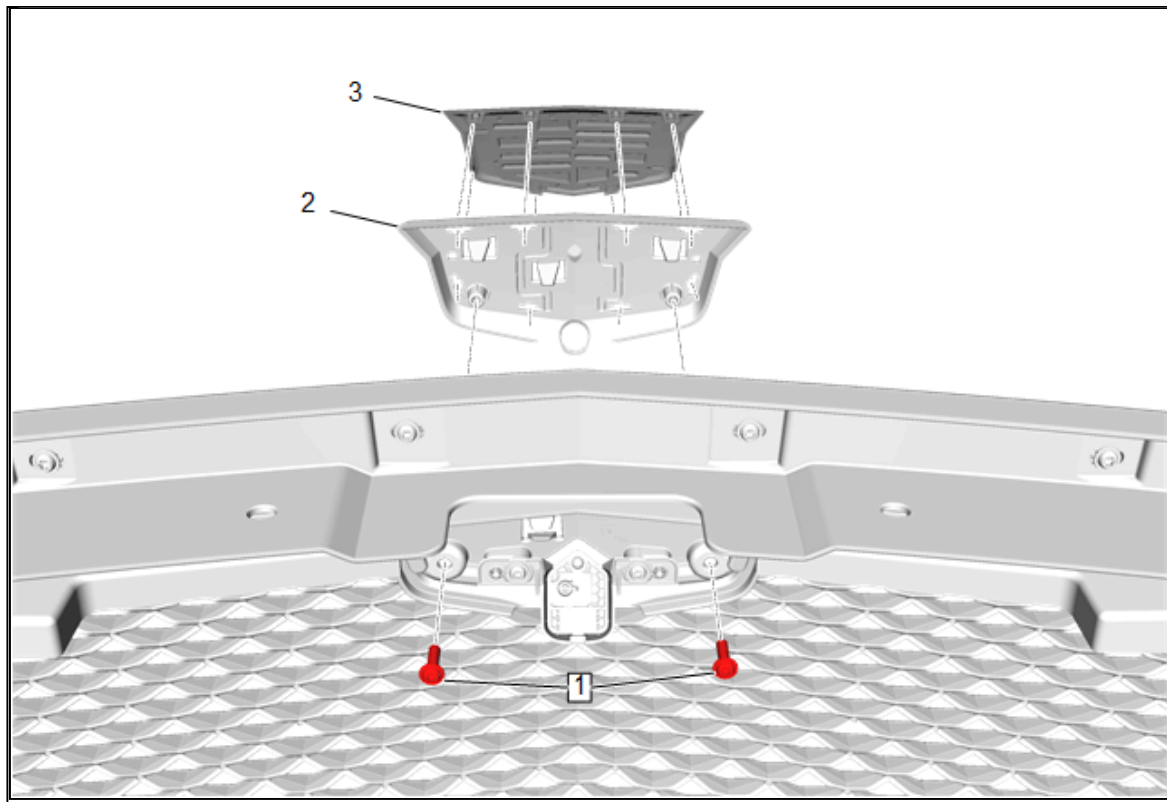

28. Remove the bolts (1) qty:2 from the front grille emblem adapter.
29. Using a suitable trim tool, release the locking tabs while carefully pulling the front grille emblem adapter (2) from the front grille.
30. Using a suitable flat-bladed tool, release the locking tabs and remove the front grille emblem (3) from emblem adapter.

### **Install Front Emblem**

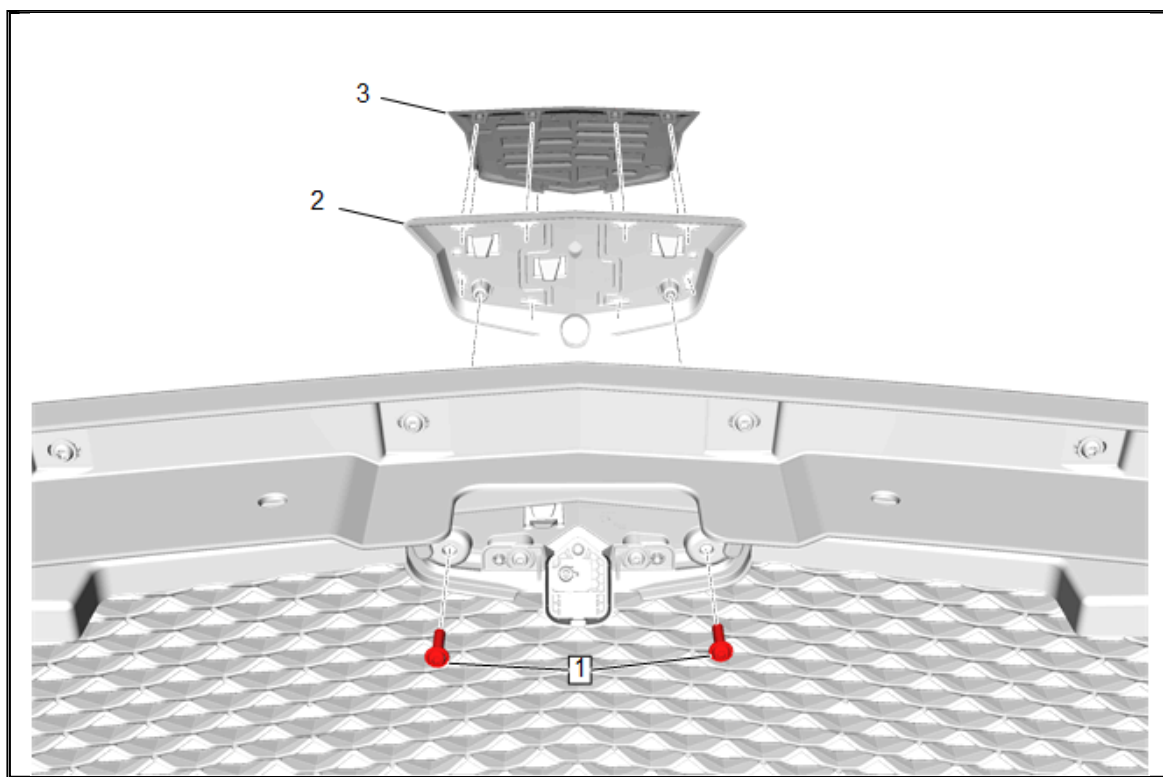

1. Accurately position the new front grille emblem (3) to the emblem adapter (2) and engage the locking tabs.
2. Apply enough evenly distributed pressure to engage the locking tabs.

**Caution:** Use the correct fastener in the correct location. Replacement fasteners must be the correct part number for that application. Fasteners requiring replacement or fasteners requiring the use of thread locking compound or sealant are identified in the service procedure. Do not use paints, lubricants, or corrosion inhibitors on fasteners or fastener joint surfaces unless specified. These coatings affect fastener torque and joint clamping force and may damage the fastener. Use the correct tightening sequence and specifications when installing fasteners in order to avoid damage to parts and systems.

3. Position the front grille emblem adapter (2) from the front grille and engage the locking tabs.
4. Apply enough evenly distributed pressure to engage the locking tabs.
5. Install the bolts (1) qty:2 to the front grille emblem adapter. Tighten the bolts to 4.7 N.m (42 lb in).

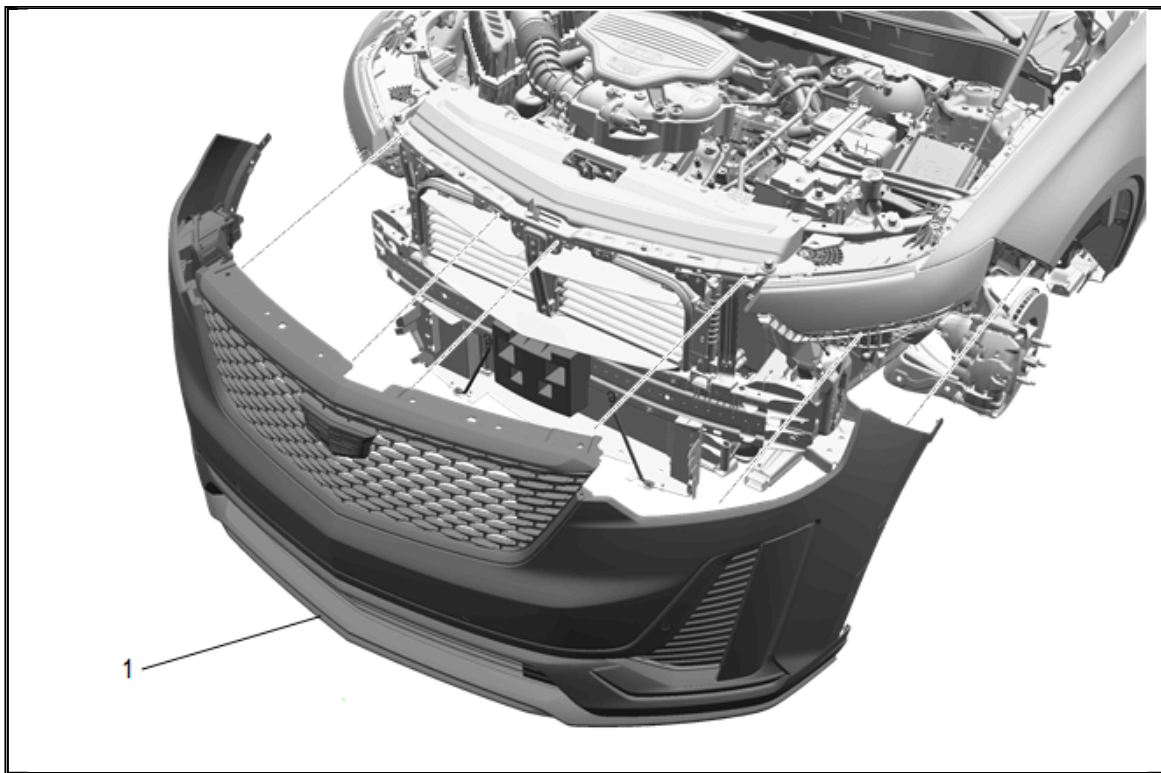

6. With the aid of an assistant, install the fascia. (1)

7. Connect the electrical connectors.

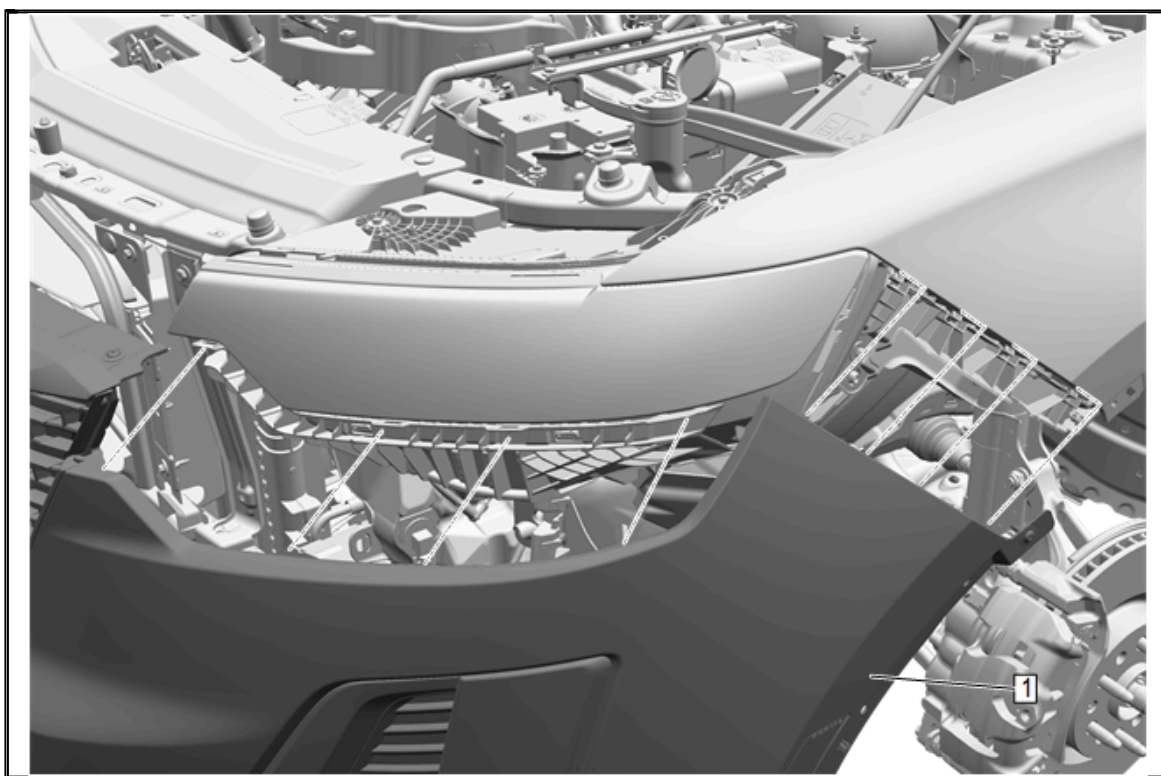

8. Install the front bumper fascia (1) to the left headlamp and front bumper fascia guide.

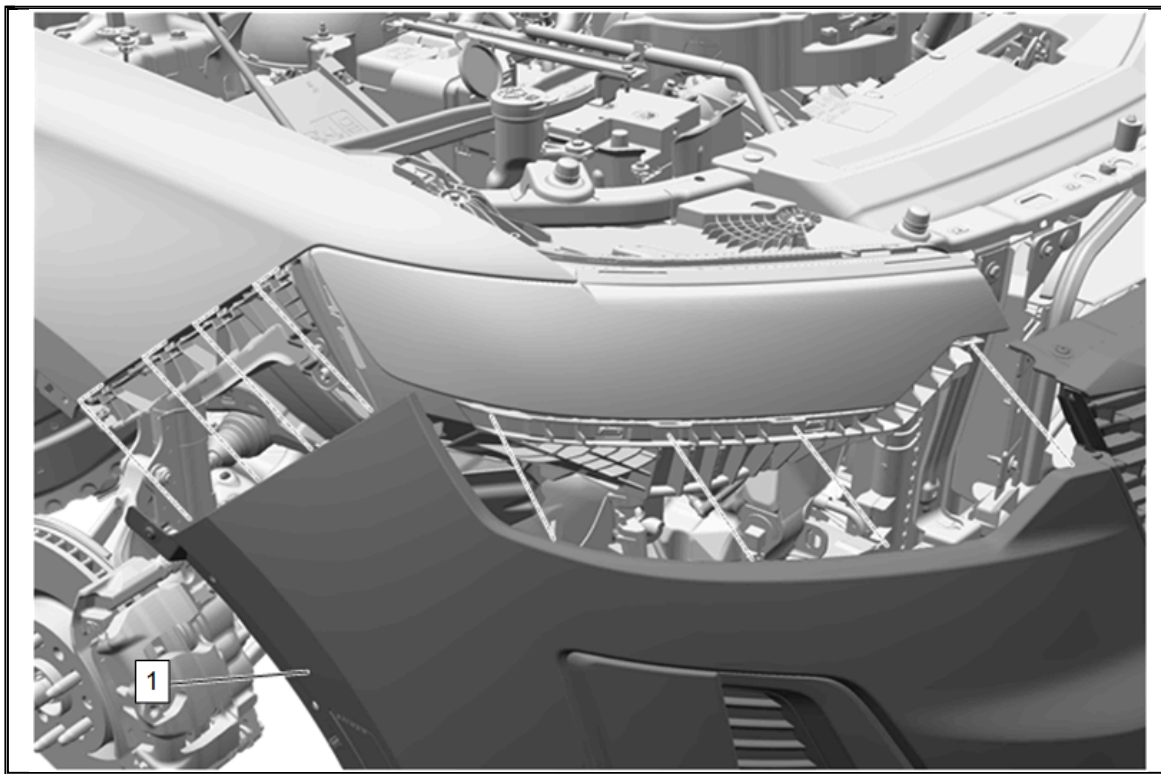

9. Install the front bumper fascia (1) to the right headlamp and front bumper fascia guide.

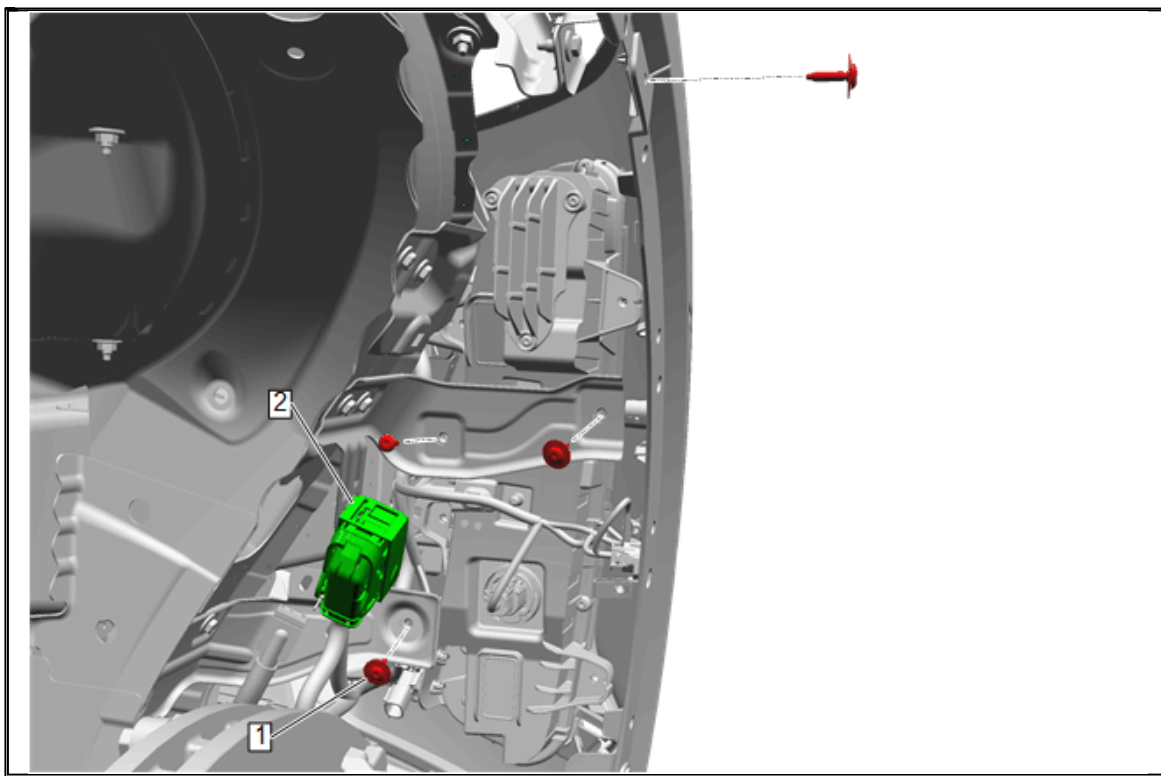

10. Install and tighten the 4 front bumper fascia bolts (1) to the right side and tighten to **2.5 N•m (22 lb in)** .
11. Connect the electrical connector. (2)

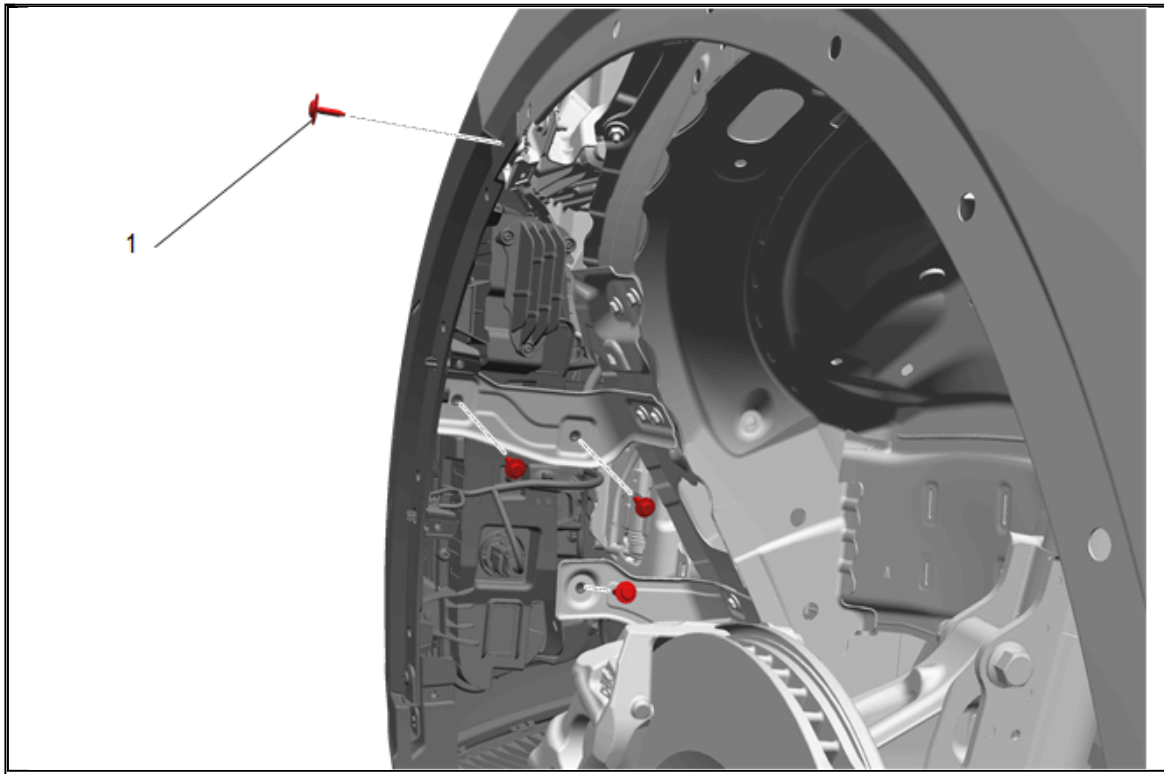

12. Install the 4 front bumper fascia bolts (1) to the left side and tighten to **2.5 N•m (22 lb in)** .

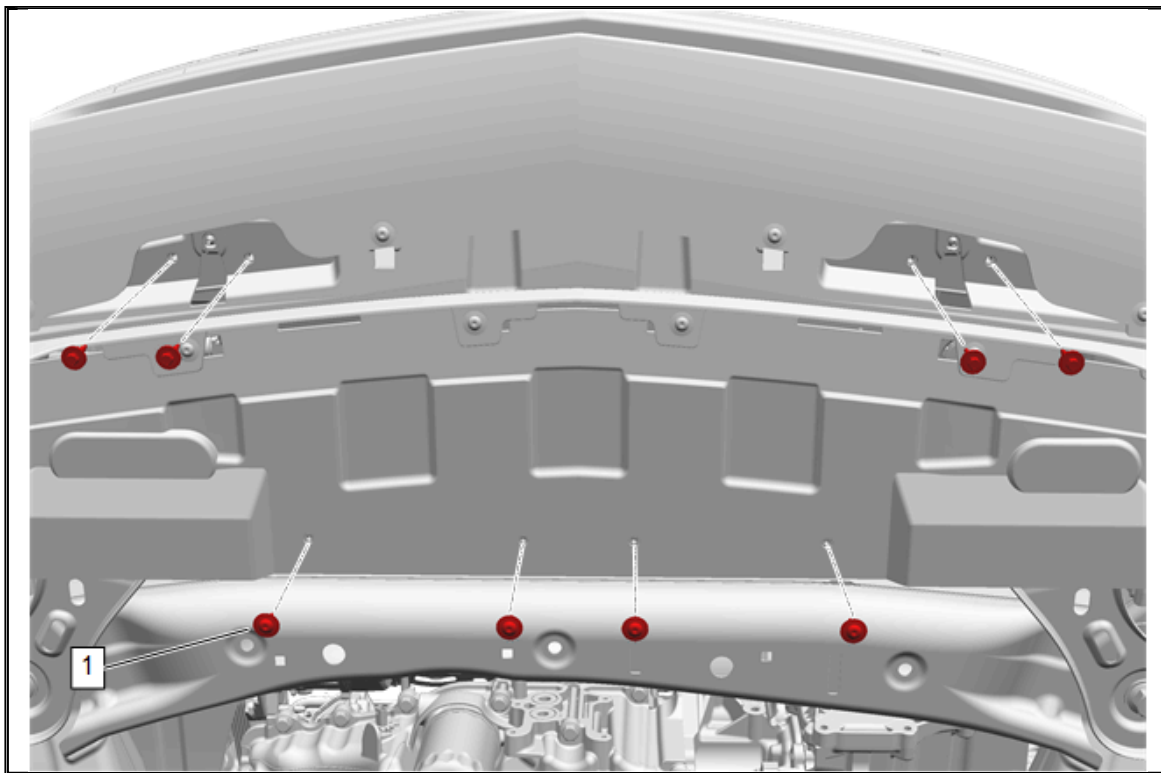

13. Front Bumper Fascia Bolt (1) » Install and tighten [8x] **2.5 N•m (22 lb in)** .

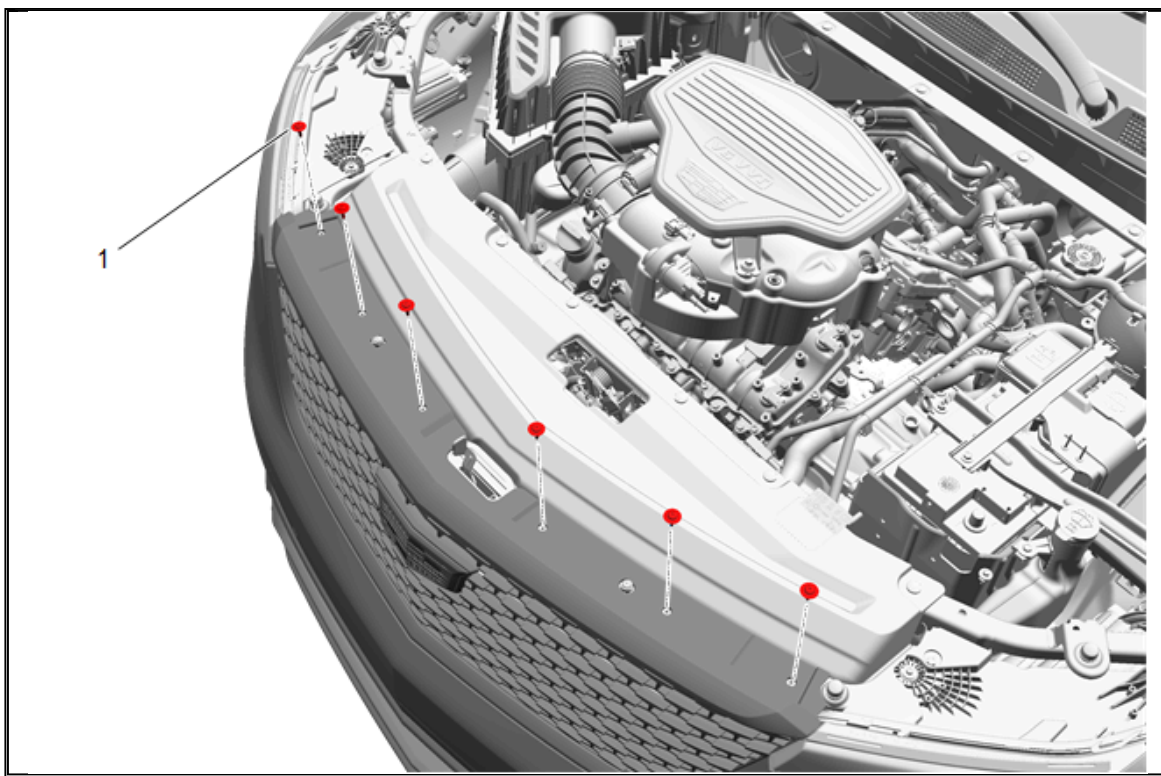

14. Front Bumper Fascia Bolt (1) » Install and tighten [6x] **2.5 N•m (22 lb in)** .

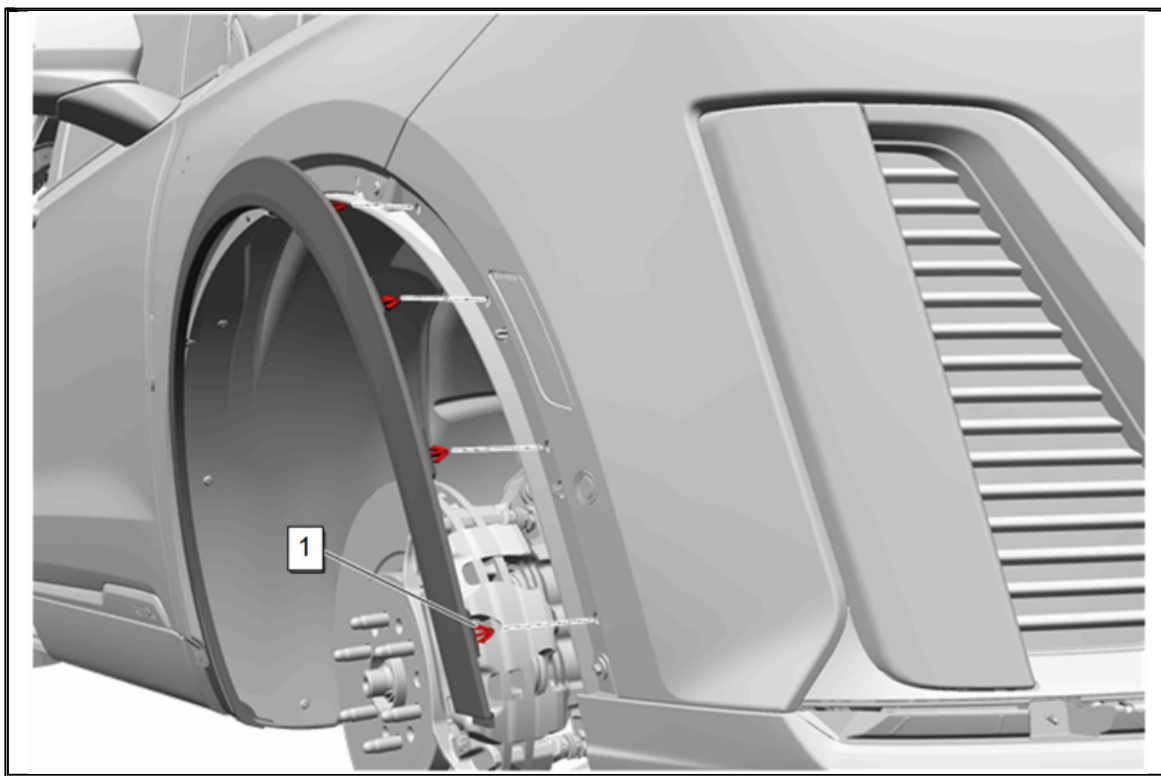

15. Install the right front wheel opening molding in the front bumper lower fascia.
16. Install the right front wheel opening molding by engaging the 4 retainers (1).
17. Remove the double layer of masking tape around the perimeter of the painted surfaces.
18. Using a 50/50 mixture of isopropyl alcohol and clean drinkable water and a clean towel, remove the left over adhesive residue from the masking tape.

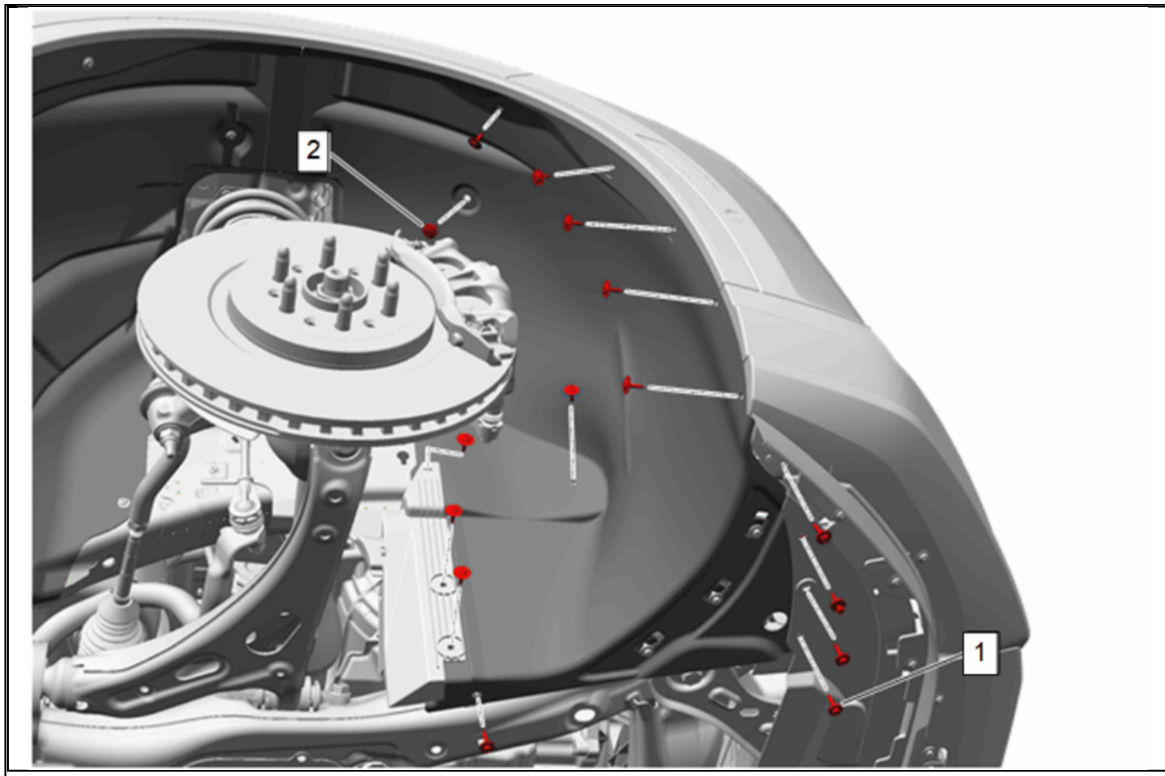

19. Install the right side front wheelhouse liner retainer (2).
20. Install the 14 right side front wheelhouse liners bolts (1). Tighten bolts to 2.5 N.m (22 lb in).

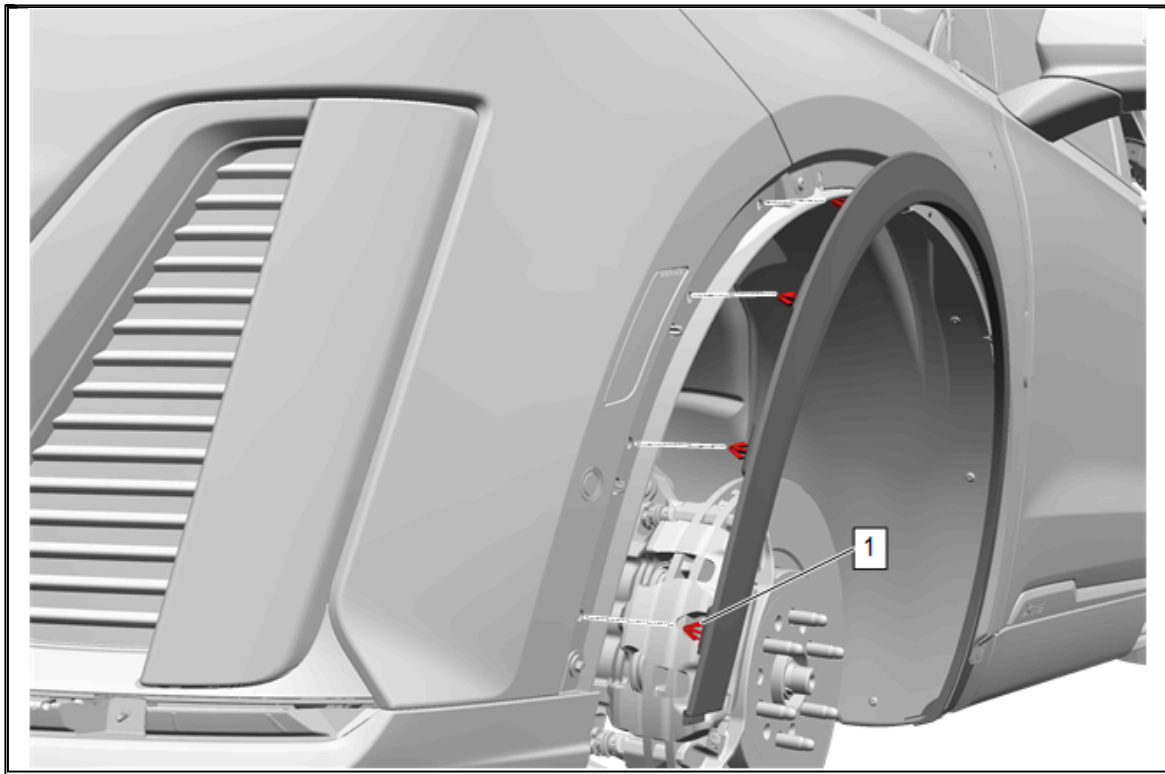

21. Install the left front wheel opening molding in the front bumper lower fascia.
22. Install the left front wheel opening molding by engaging the 4 retainers (1).
23. Remove the double layer of masking tape around the perimeter of the painted surfaces.
24. Using a 50/50 mixture of isopropyl alcohol and clean drinkable water and a clean towel, remove the left over adhesive residue from the masking tape.

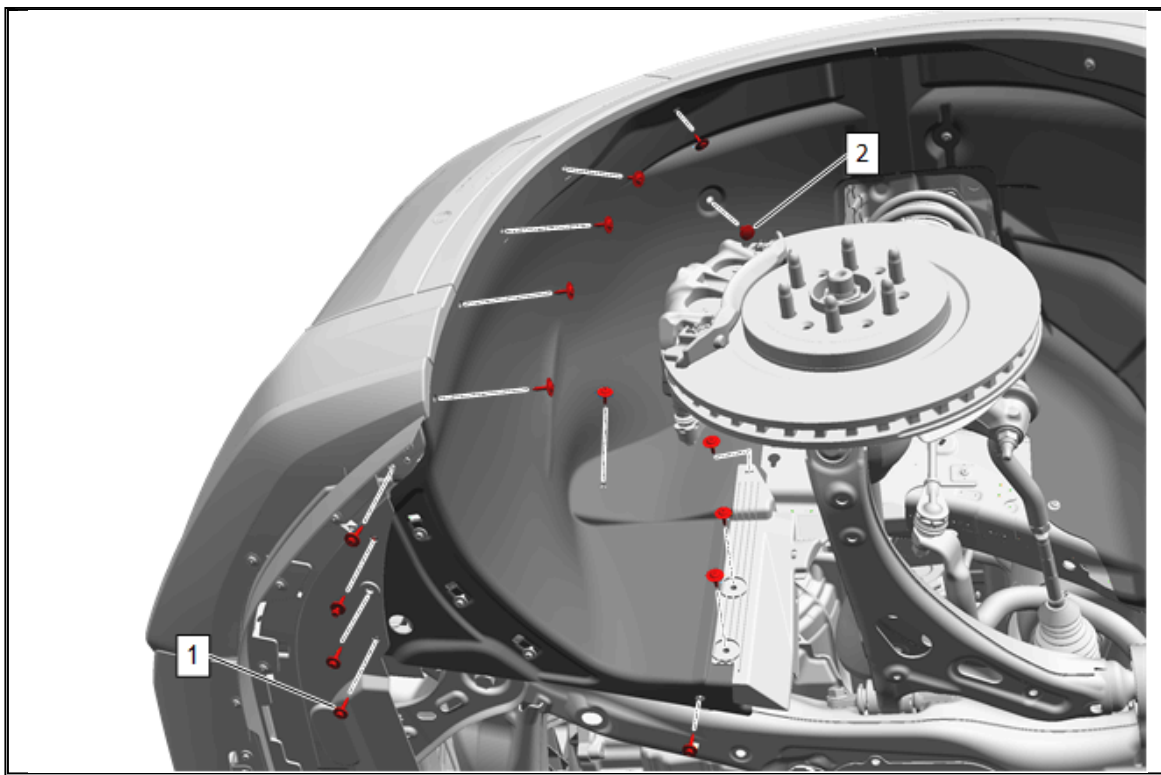

25. Install the left side front wheelhouse liner retainer (2).
26. Install the 14 left side front wheelhouse liners bolts (1). Tighten bolts to 2.5 N.m (22 lb in).
27. Install both front tires. Refer to [Tire and Wheel Removal and Installation](#) in Vehicle Service Manual.
28. Ensure all electrical connections are intact, test any front lighting to confirm it is functioning.
29. Remove the support and lower the vehicle.
30. Close the hood.

### **Remove Rear Emblem**

1. Turn off vehicle.
2. Open liftgate.



3. Using a flat bladed plastic trim tool, disengage the clips at the rear portion of the liftgate trim finish panel and then pull from the trim near the hatch glass to avoid twisting or breaking the retainers near the glass.
4. Disconnect the electrical connectors and remove the liftgate trim finish panel (1) from the liftgate.



5. Using a flat bladed plastic trim tool, release the liftgate upper center trim finish panel (1) from the liftgate inner panel.

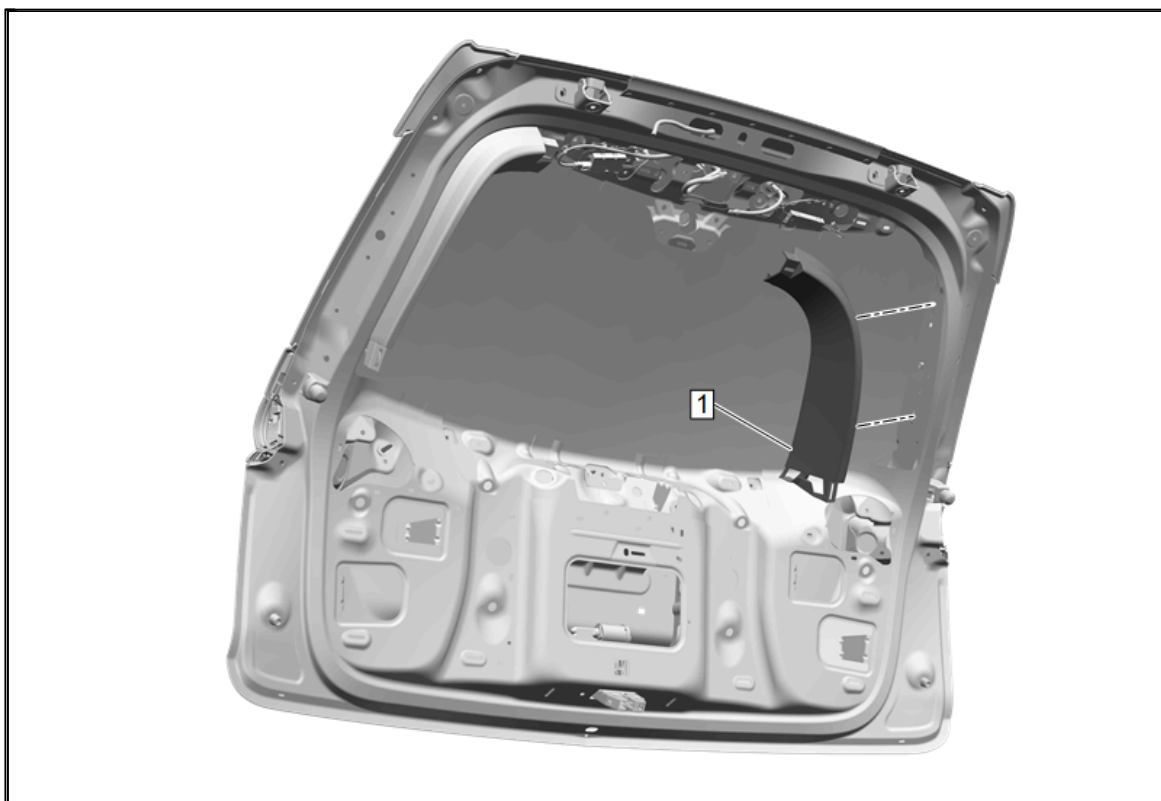

- Using a flat bladed plastic trim tool, remove the liftgate upper side trim finish panel (1) from the liftgate. Repeat for opposite side.

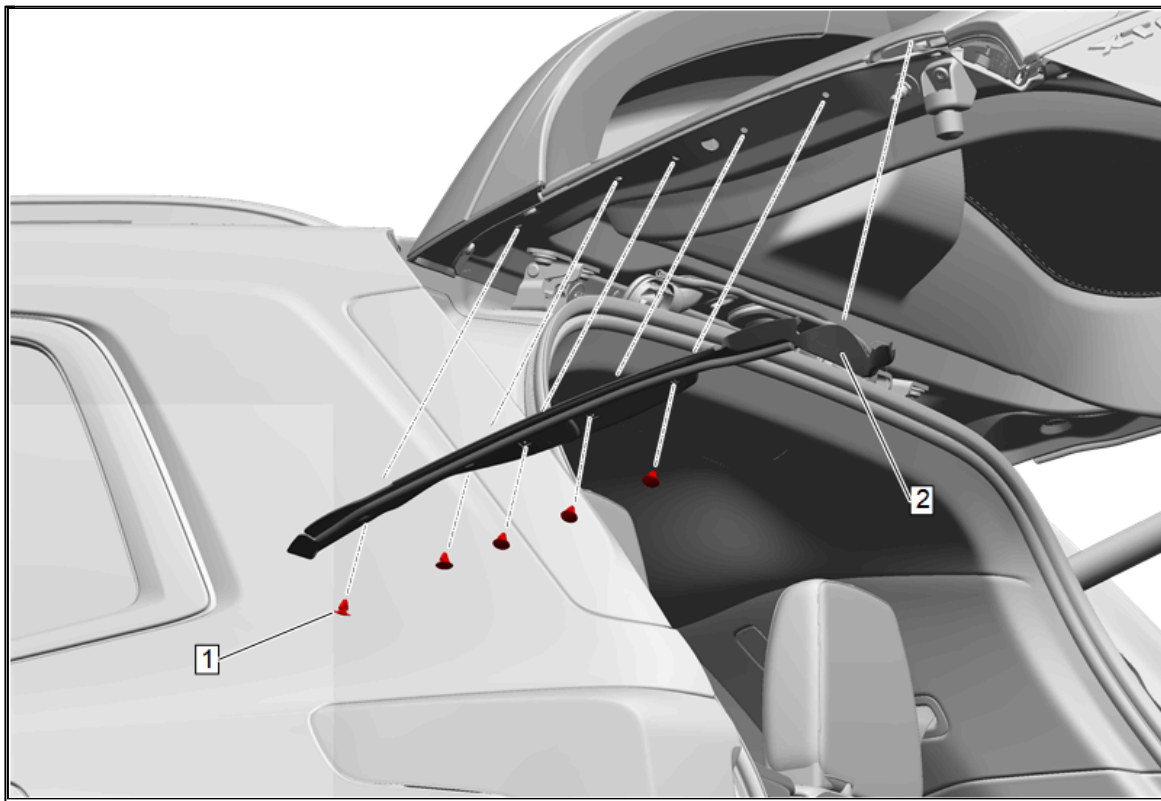

- Using a flat bladed plastic trim tool, disengage the retainers (1), disconnect electrical connector and remove the left liftgate side sensor (2) from the liftgate. Discard retainers.

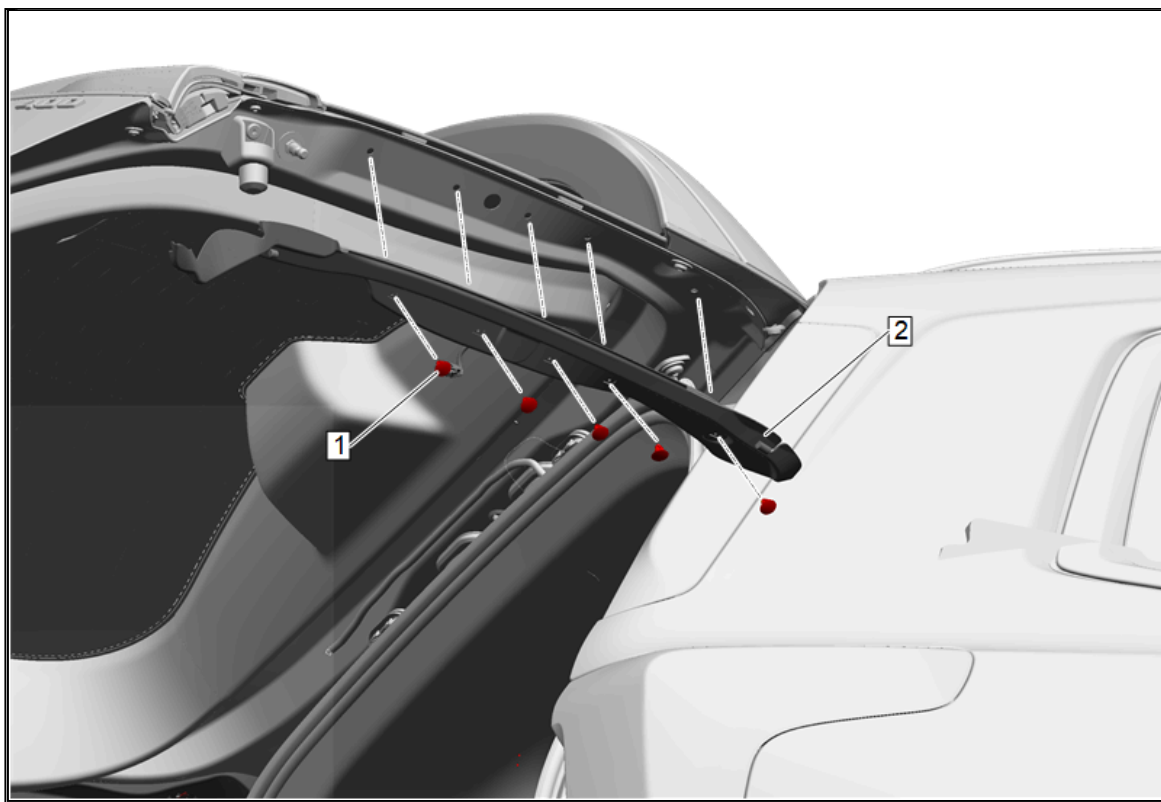

8. Using a flat bladed plastic trim tool, disengage the retainers (1), disconnect electrical connector and remove the right liftgate side sensor (2) from the liftgate. Discard retainers.

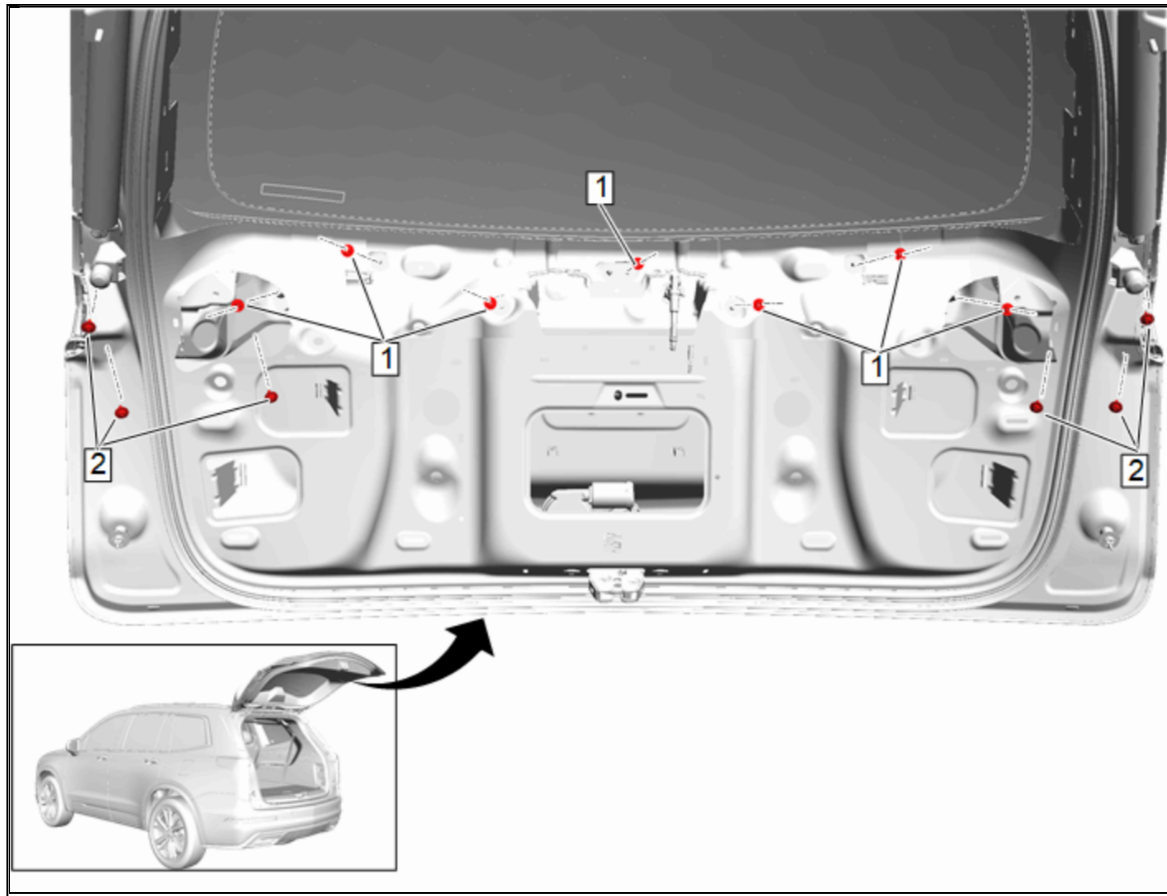

9. Rear Closure Center Applique Nut (1) » Remove [7x]
10. Rear Closure Center Applique Bolt (2) » Remove [6x]
11. Disconnect the electrical connectors.

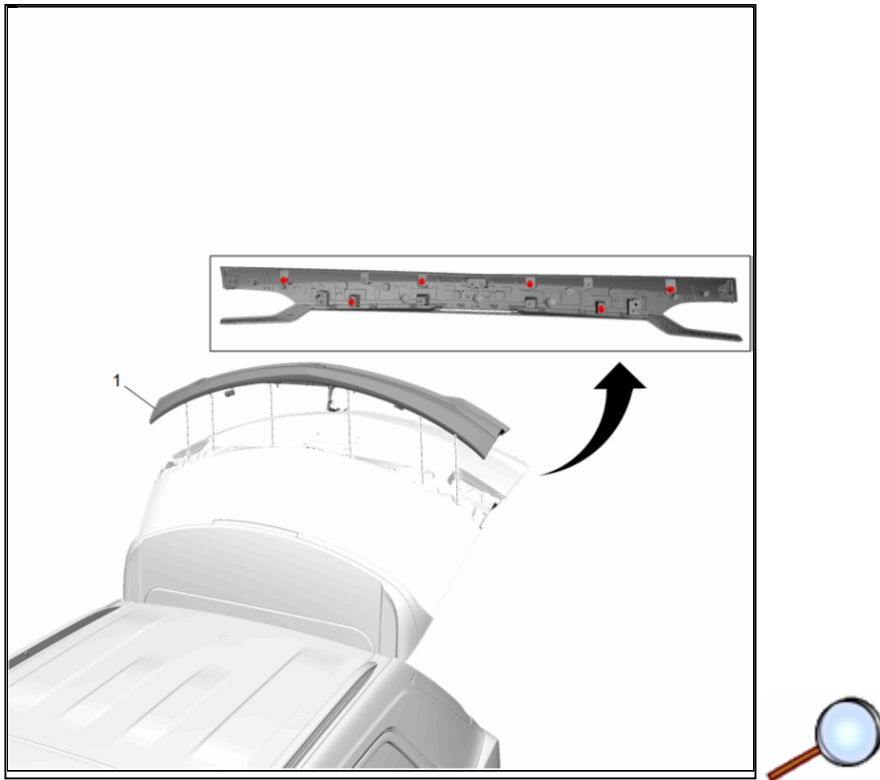

12. Release the retainers.

13. With the help of an assistant, remove the rear closure center applique (1).

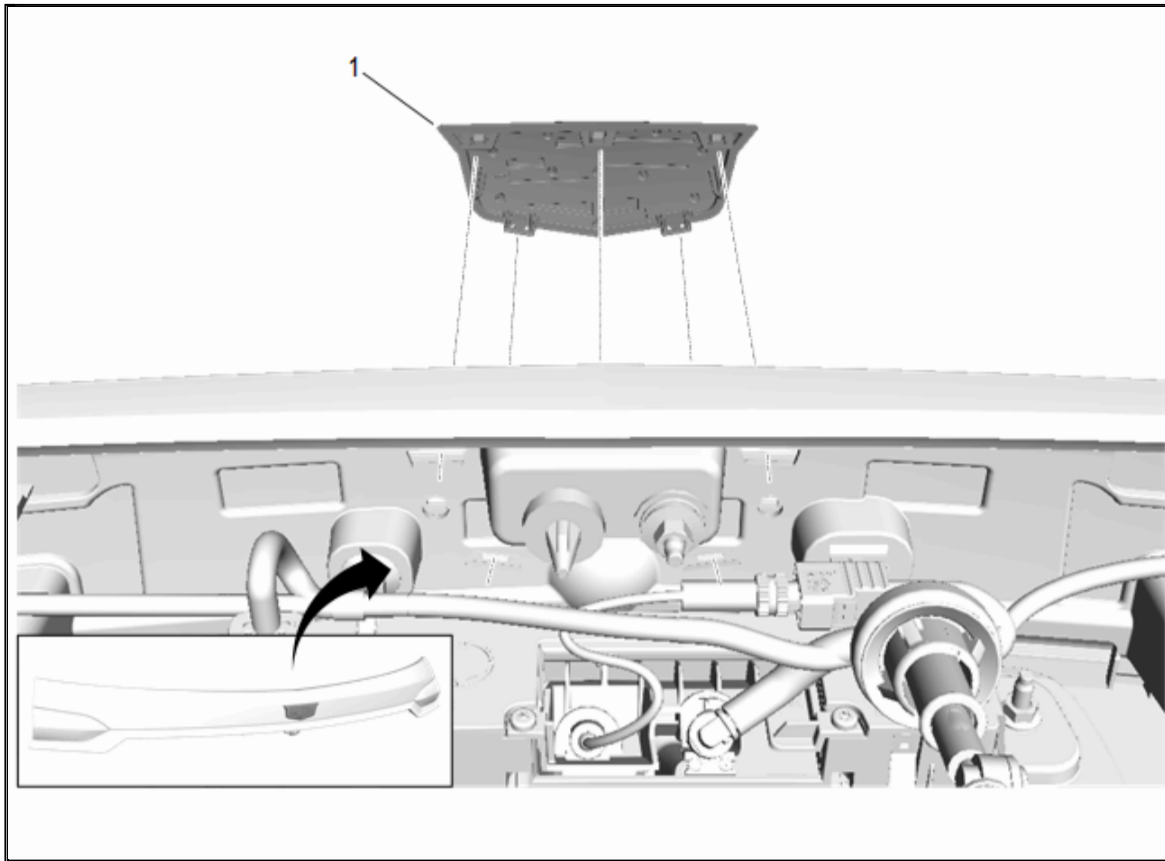

**Caution:** Use a plastic, flat-bladed tool to prevent paint damage when removing an emblem/name plate.

14. Using a suitable plastic flat bladed tool, release the locking tabs from the lift gate emblem and remove emblem (1) from rear closure center applique.

### Install Rear Emblem

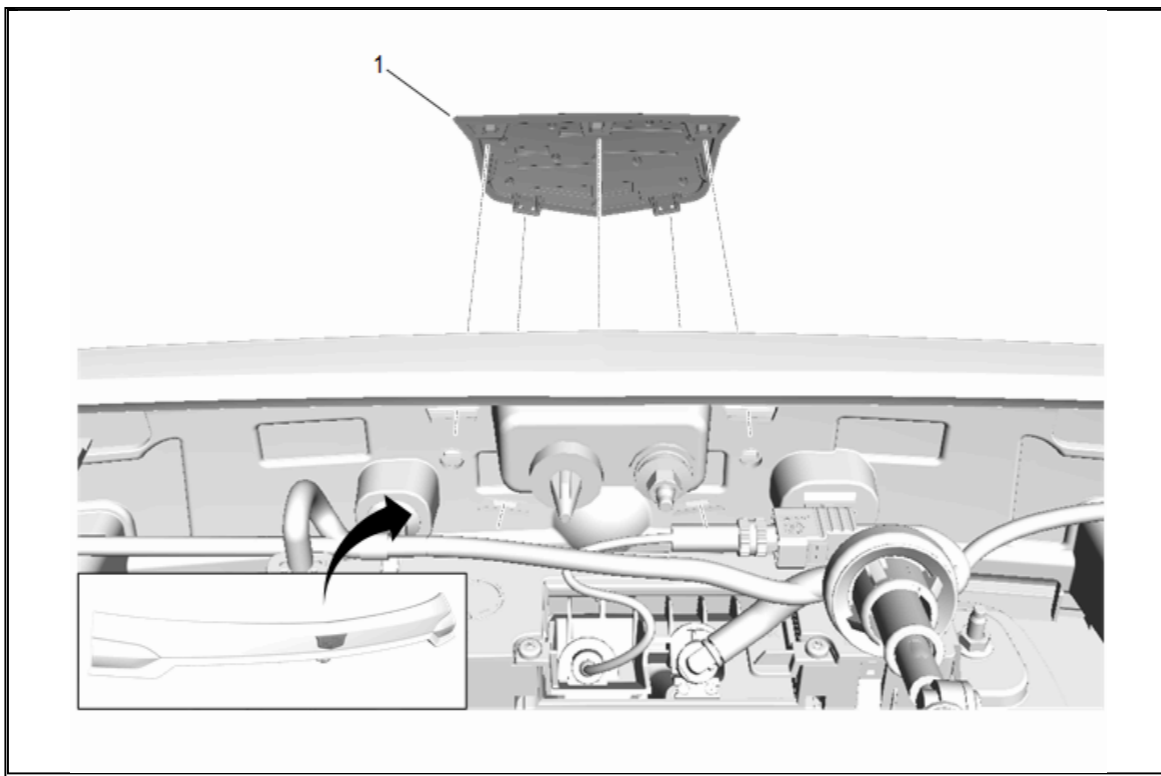

1. Install the lift gate emblem (1) to the rear closure center applique making sure to engage the locking tabs.

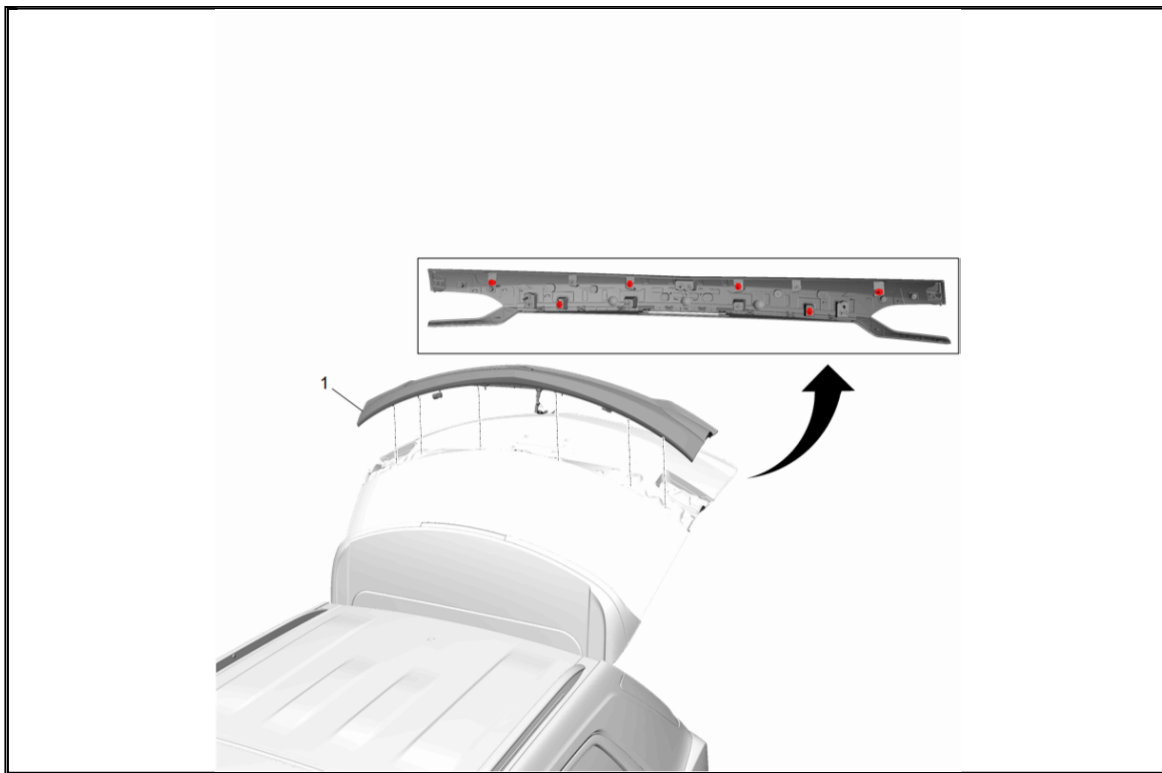

2. Rear Closure Center Applique (1) » Install
3. Connect the electrical connectors.

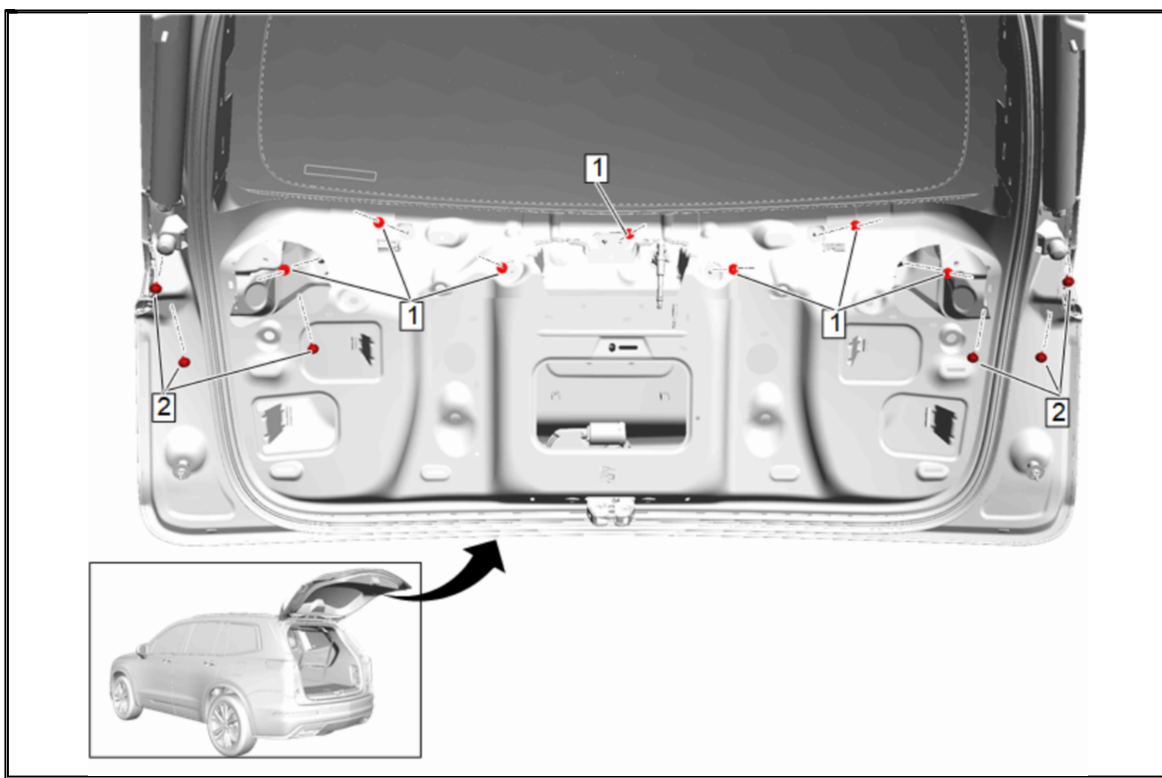

**Caution:** Refer to [Fastener Caution](#).

4. Rear Closure Center Applique Bolt (2) » Install and tighten [6x] **4.7 N•m (42 lb in)**
5. Rear Closure Center Applique Nut (1) » Install and tighten [7x] **4.7 N•m (42 lb in)**

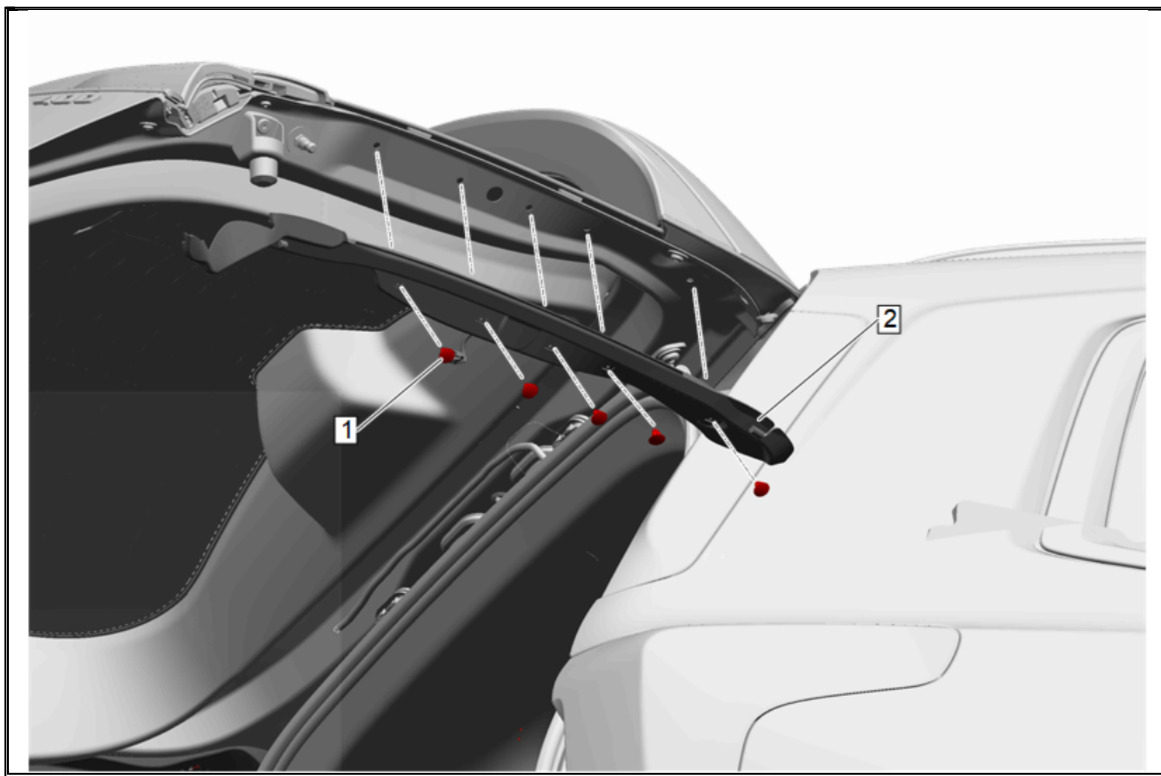

**Note:** Install **NEW** retainers. Do **NOT** reuse old retainers.

6. Position the right liftgate side sensor (2) to the liftgate, connect electrical connector and engage the retainers (1).

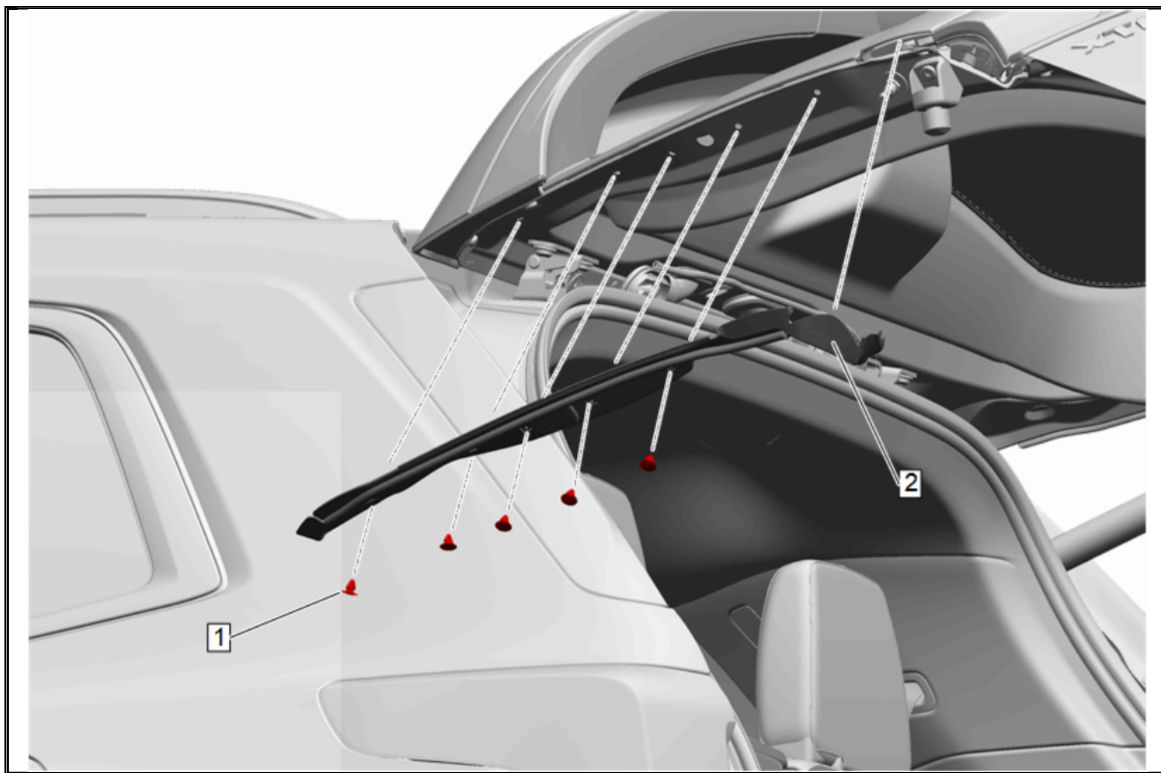

**Note:** Install NEW retainers. Do NOT reuse old retainers.

7. Position the left liftgate side sensor (2) to the liftgate, connect electrical connector and engage the retainers (1).

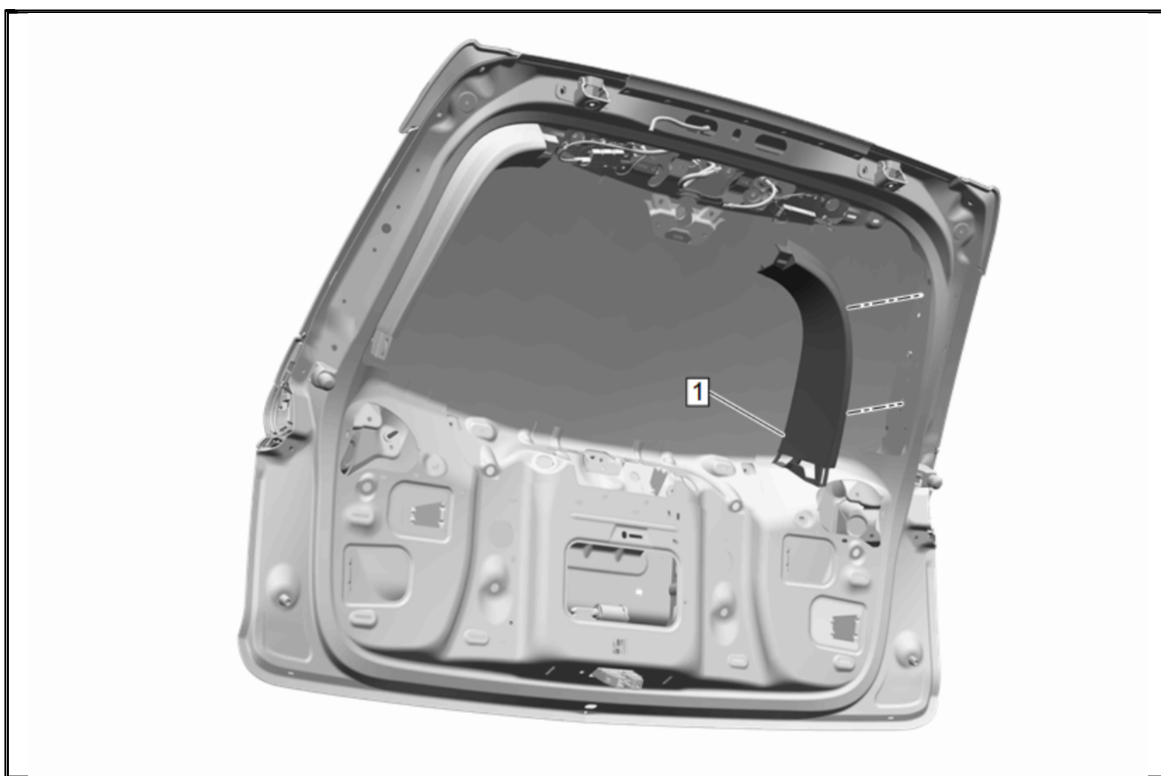

8. Install the liftgate upper side trim finish panel (1) to the liftgate, engage the retainers. Repeat for opposite side.



9. Install the liftgate upper center trim finish panel (1) to the liftgate inner panel , engage the retainers.



10. Position the liftgate trim finish panel (1) to the liftgate and connect the electrical connectors, engage the clips.
11. Close liftgate.