

# Rear Mud Guard Package Installation

## Installation Instructions Part Number

84938121

**Note:** Please read instructions thoroughly before starting.

### Rear Mud Flap Guard Kit Contents

Qty	Description
1	Left Hand Splash Guard
1	Right Hand Splash Guard
1	Left Hand Splash Guard Bracket
1	Right Hand Splash Guard Bracket
2	Rivet
2	M4.2 x 25 Screw
6	M4.2 x 20 Screw
8	M4.2 U-Nut
2	Alcohol Prep-Wipes
1	Instruction Sheet

### Tools Required

- T15 Torx Bit
- Drill with 1/4" (6.35 mm) and 13/64" (5.0mm) Drill Bit
- Rivet Gun
- Awl
- Pliers
- Measuring Tape
- Clean Cloth/Rag

## Preliminary Procedure

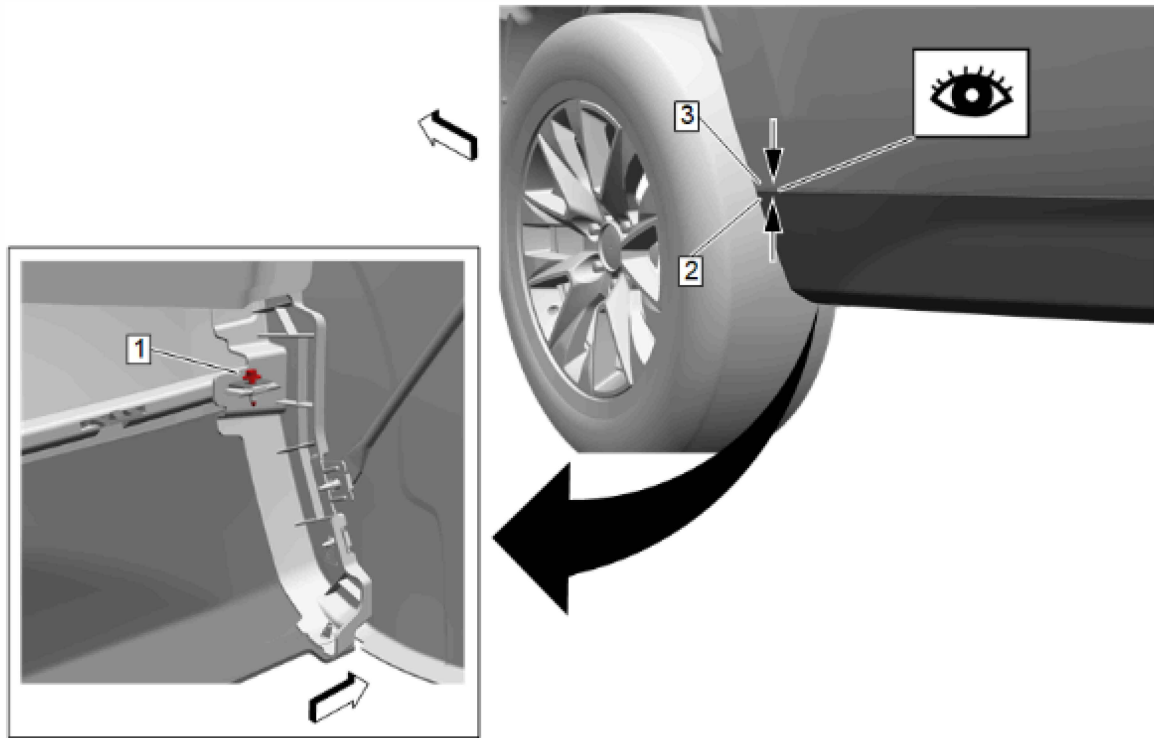

**Note:** On some vehicles it may be required to align the lower rear fascia to the upper rear fascia where the splash guard is installed in order to achieve proper fitment. Follow these preliminary steps if necessary.

1. From the backside of the rear fascia locate the bolt (1) nearest to the rear tire and loosen.

**Caution:** Use the correct fastener in the correct location. Replacement fasteners must be the correct part number for that application. Fasteners requiring replacement or fasteners requiring the use of thread locking compound or sealant are identified in the service procedure. Do not use paints, lubricants, or corrosion inhibitors on fasteners or fastener joint surfaces unless specified. These coatings affect fastener torque and joint clamping force and may damage the fastener. Use the correct tightening sequence and specifications when installing fasteners in order to avoid damage to parts and systems.

2. Apply pressure to the rear lower fascia (2) until it aligns flush with the upper fascia (3). Keep pressure on rear lower fascia and tighten bolt (1) to 2.5 N.m (22 lb in).

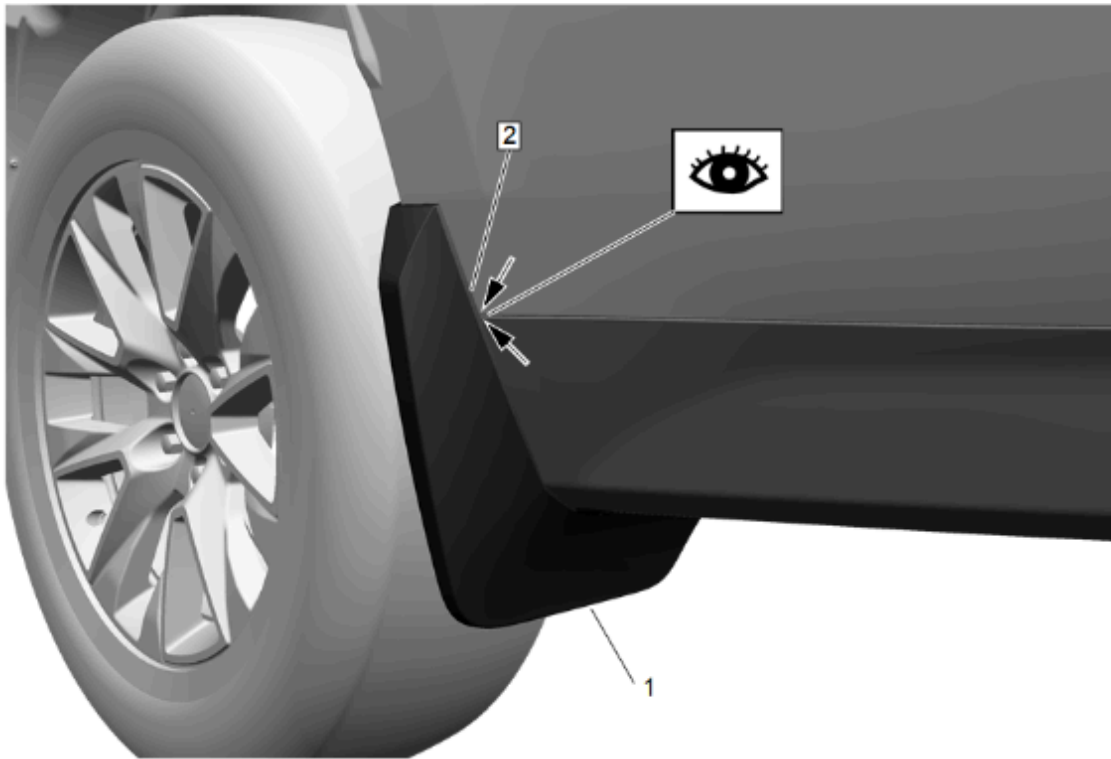

3. Position the rear splash guard (1) to the rear fascia to confirm side of splash guard (2) is flush to upper and lower fascia.
4. Repeat preliminary steps for opposite side if necessary.

### Installation Procedure

**Note:** Do not use power tools to install splash guard fasteners.

1. Remove rear wheel and tire assembly. Refer to [Tire and Wheel Removal and Installation](#) in Vehicle Service Manual.
2. Clean and degrease body panel where splash guards will be located.
3. Using supplied alcohol wipes, clean area where tape makes contact to body.

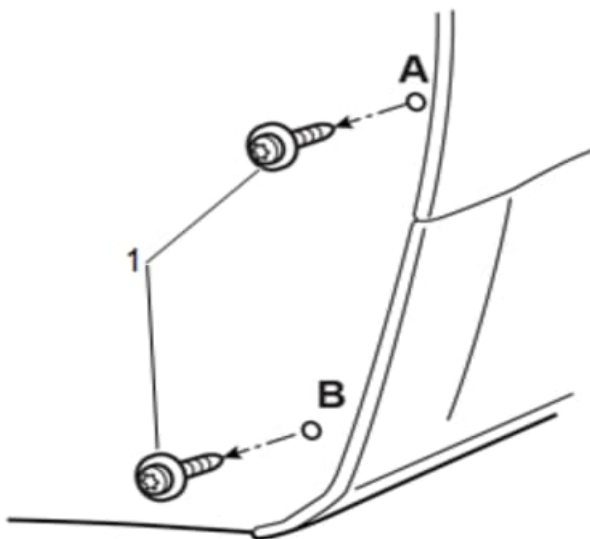

4. Remove and retain existing screws (1) at locations (A) and (B).

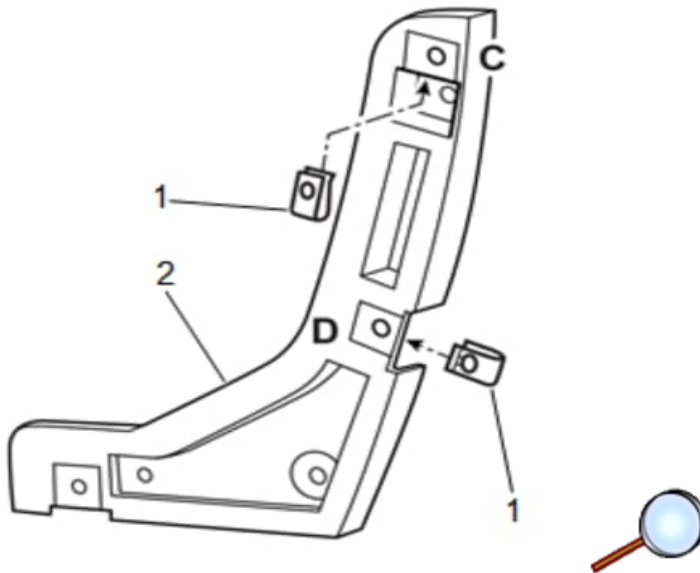

**Caution:** Use the correct fastener in the correct location. Replacement fasteners must be the correct part number for that application. Fasteners requiring replacement or fasteners requiring the use of thread locking compound or sealant are identified in the service procedure. Do not use paints, lubricants, or corrosion inhibitors on fasteners or fastener joint surfaces unless specified. These coatings affect fastener torque and joint clamping force and may damage the fastener. Use the correct tightening sequence and specifications when installing fasteners in order to avoid damage to parts and systems.

5. Place supplied u-nuts (1) onto supplied bracket (2) at locations (C) and (D).

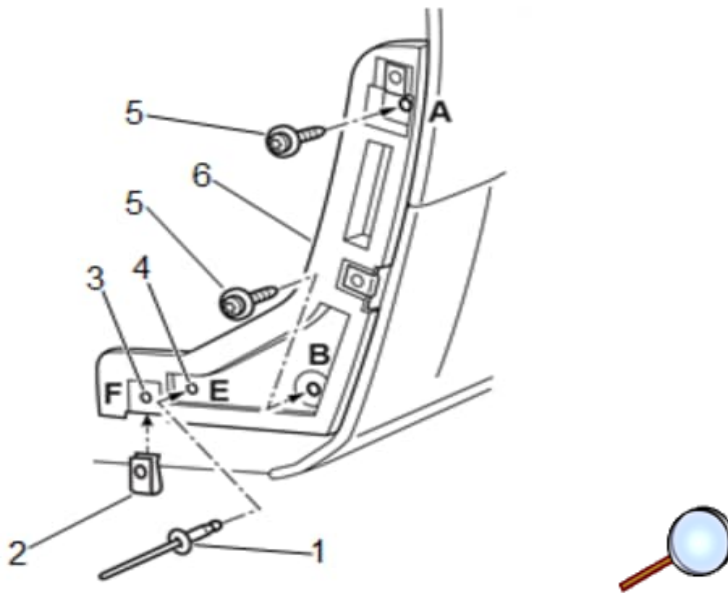

**Caution:** Always check scale, size and position of all templates before drilling. Failing to do so may cause damage to the vehicle, misalignment of components or the inability to install the accessory.

6. Place bracket (6) to vehicle and install retained screws (5) at locations (A) and (B). Hold bracket tight to wheel liner and drill a 13/64" (5.0 mm) hole (4) at location (E) then drill a 1/4" (6.35 mm) hole (3) at location (F).

**Note:** Make sure hole is large enough for the u-nut barrel to pass through.

7. While pulling bracket toward you install supplied u-nut (2) at location (F). Install rivet (1) at location (E).

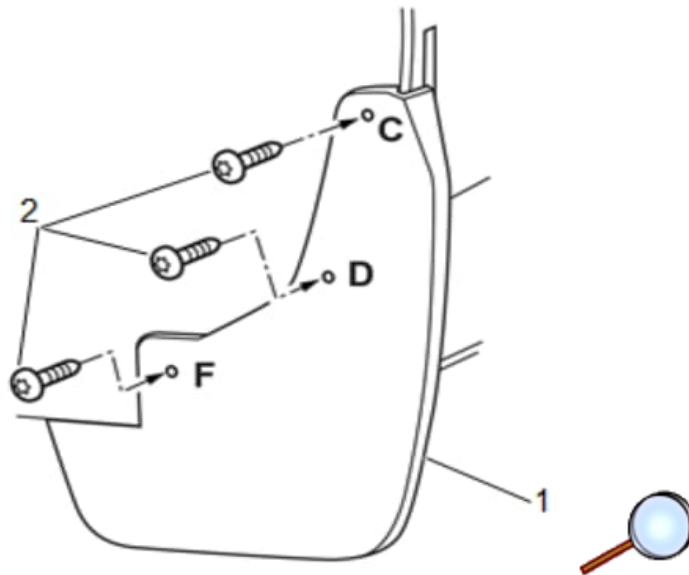

8. Place splash guard assembly (1) to bracket taking care to remove any gaps to the vehicle, make sure red tape pull tab is accessible, and install supplied M4.2 x 20 screws (2) at locations (C),(D) & (F).

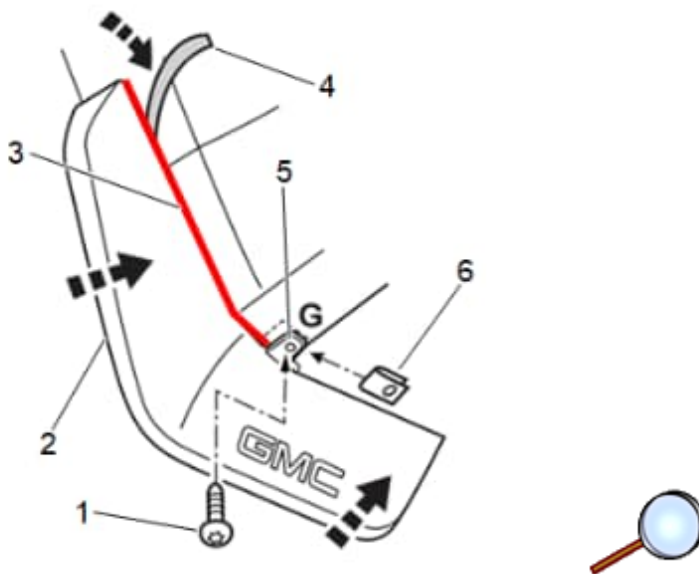

9. Pull Splash Guard (2) rearward and inboard to manipulate and minimize any gaps (3) to the rear fascia.
10. While holding bottom of splash guard in best position to minimize gaps, mark and drill a 13/64" (5.0 mm) hole (5) at location G.
11. Install supplied M4.2 x 25 screw (1) and U-nut (6) at location (G). U-nut should be used as a nut above fascia.
12. Remove tape liner (4) and apply firm pressure to the splash guard along the tape line to adhere the tape to the fender. Hold the firm pressure for a minimum of 60 seconds to properly adhere the tape.
13. Install rear wheel and tire assembly. Refer to [Tire and Wheel Removal and Installation](#) in Vehicle Service Manual.
14. Repeat for other side.
15. Guards can be cleaned with any commercially available cleaner.

**Note:** Maximum torque on M4.2 screw is 3.0 N.m (27 lb in).