

Hood Decal Package Installation

Installation Instructions Part Number

84973879

To enable a successful installation of decals please refer to 52524.01V Accessory Decal Installation Tips and Tricks video at <https://techtube.gallery.video/detail/video/5991123051001/52524.01v-accessory-decal-installation-tips-and-tricks?autoStart=true&q=decals>

Note: Video is referenced from GM Tech Tube in Center of Learning.



Hood Decal Package Installation

ITEM	DESCRIPTION	QUANTITY
1	Decal - Hood Inner "Moonscape"	1
2	Decal - Hood Outer "U" Shape	1
-	Plastic Squeegee	1
-	Installation Instructions with Paper Alignment Templates	1

IMPORTANT NOTES

1. The installation of these decals is difficult; the employment of a trained installation professional (ADI) is recommended.
2. For optimum results, the body surface should be between 70°F/21°C and 90°F/32°C at the time of installation and for a minimum of 30 minutes after.
3. Power-washing decals is discouraged. If used, a power-wash wand can not be within 24 inches of the decal and should never be pointed at an edge.
4. The use of a wax, polish or buffing wheel is strongly discouraged, as the surface finish can be damaged and/or modified.

Caution: After a decal installation has been complete, do not high pressure wash the vehicle for 72 hours.

Tools Required

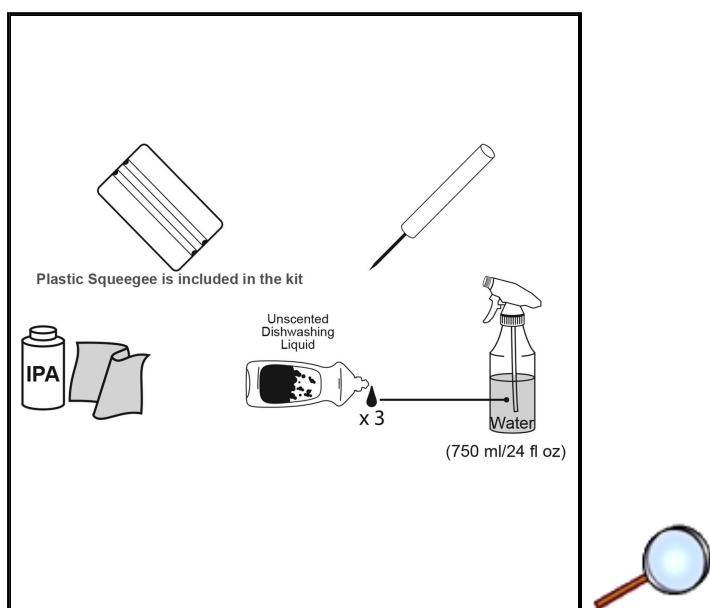

Note: To ensure a bubble free application, put three drops of liquid dish soap into a trigger type plastic spray bottle. Set nozzle for "fine mist".

- Water
- Lint-free towels
- Unscented Liquid Dish Soap

Note: Do NOT use Commercial premixed soap solution.

- Trigger-Type Spray Bottle
- Isopropyl Alcohol
- Plastic Squeegee (Included in the kit)

Note: Only use the included plastic squeegee to work the decals. Using the incorrect squeegee will damage the decals.

- Masking Tape
- Sewing Needle or Thin Pin

Note: Do NOT use a razor blade.

Preparation - Before Installation

1. Vehicle body surface and decal must be 70°F/21°C - 90°F/32°C at the time of the installation and for two hours after.
2. Initially wash the entire vehicle, then thoroughly wash the hood with warm soap and water. The paint surface where the decals are to be applied must be thoroughly cleaned and free of all contaminants.
3. If present, heavy contamination like tar should be removed with Prepsol or other quality solvent.
4. Wipe the paint surface with Isopropyl Alcohol just before starting the application. Follow with a dry lint-free towel.
5. To ensure a bubble-free application, put three drops of liquid dish soap into a 24 oz. trigger-type spray bottle and fill it with water. Replace the top and shake to mix the soap and water "surfactant". Set nozzle for a fine mist.

Installation Notes

1. The "surfactant" is intended to allow the installer the opportunity to position the decal into place multiple times before any pre-adhesion can occur.
2. The adhesive is activated by pressure. Be sure to use firm, overlapping strokes, beginning at the center of the decal and working toward the edges.
3. When using the squeegee, be careful not to drag the squeegee onto the painted body panel.

4. After premask carrier removal, never use an uncovered squeegee to re-press the decal into place. Wrap the squeegee with a towel or re-spray the surface before applying additional pressure.

Decal Positioning and Installation

1. Prepare the surface as described in the preparation section.
2. Position the decal onto the vehicle surface and lay pieces of masking tape along the edges of the premask carrier.
3. Lay the decal upside down on a flat surface and slowly remove the white release liner (the adhesive layer of the decal will now be exposed).
4. Spray the surfactant onto the vehicle surface where decal is to be applied.
5. Spray additional surfactant onto the exposed adhesive of the decal.
6. Carefully lay the adhesive side of the decal onto the vehicle surface, aligning the premask carrier edges to the edges of the masking tape.
7. Use a squeegee to press the decal into place, beginning at the center of the decal and working toward the edges.
8. Remove the pre-mask by pulling it off at 180° or parallel to the surface.
9. Inspect the decal for any impressions.
10. For a bubble removal, use a sewing needle or a thin pin to carefully pierce the bubble to release the trapped surfactant.

Note: The sewing needle must be inserted in the side of the bubble, not the top to prevent the sewing needle from breaking the paint and cause corrosion. See "Accessory Decal Installation Tips and Tricks" video for demonstration.

11. Do not use an automated/high pressure car wash until 72 hours have elapsed.

Procedure

Note: View "Accessory Decal Installation Tips and Tricks" video before attempting to install the decals.

Inner Hood Decal

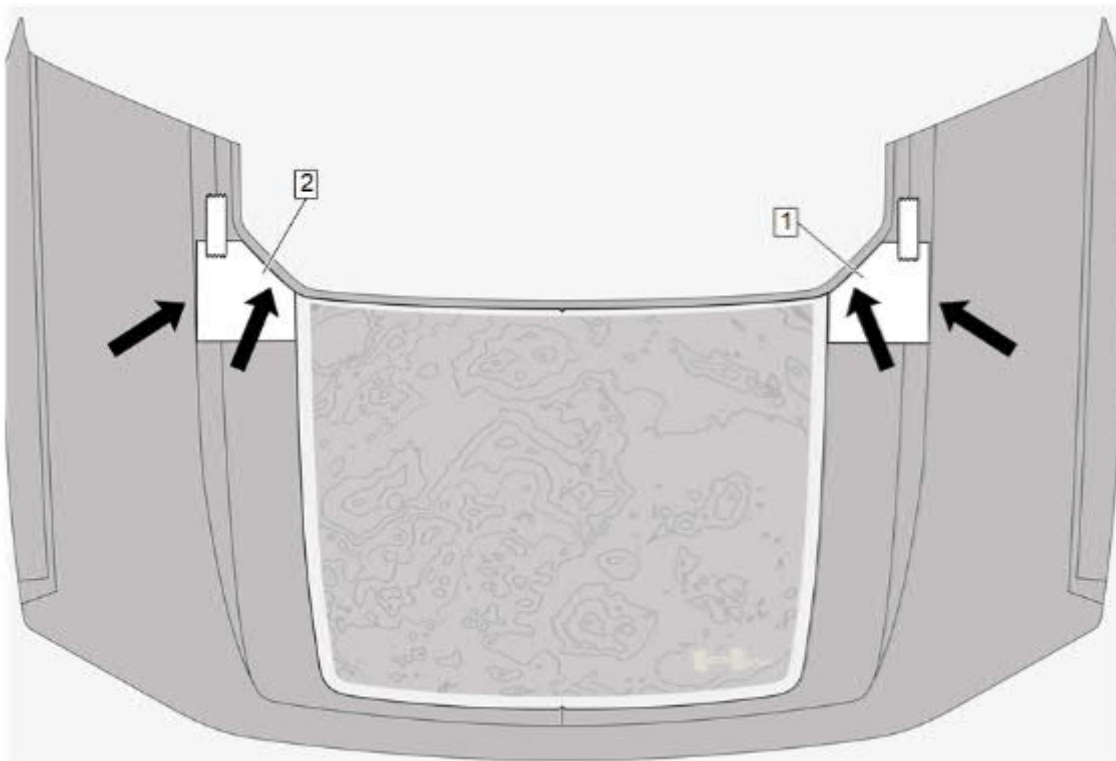

Caution: Always check size and position of templates before installation of accessory. Failing to do so, may cause misalignment of components or the inability to install the accessory.

1. Cut out LH (1) and RH (2) templates and align templates into place to hood with tape as shown.

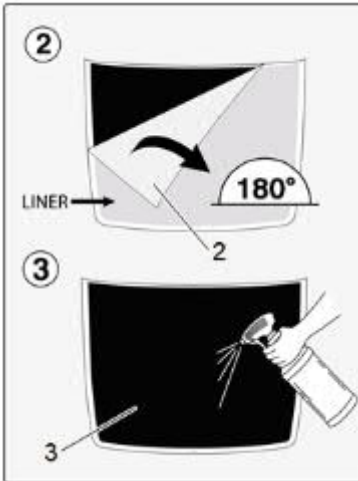
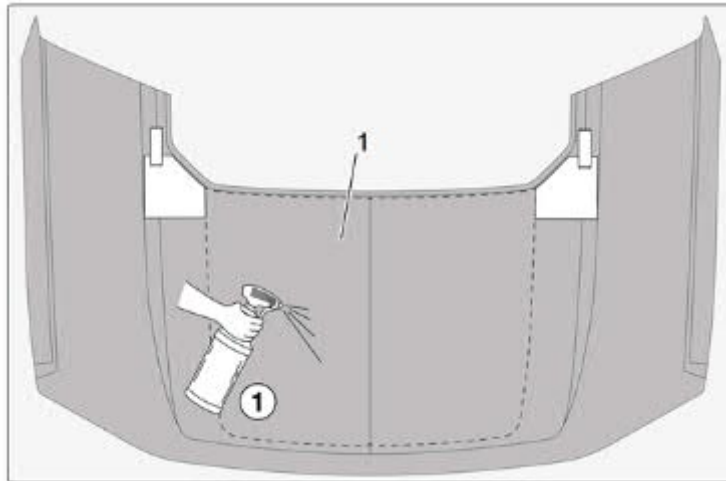

2. Spray a generous amount of surfactant onto the hood panel (1). Remove the white release liner (2) from the inner hood decal and spray a generous amount of surfactant onto the exposed adhesive (3).

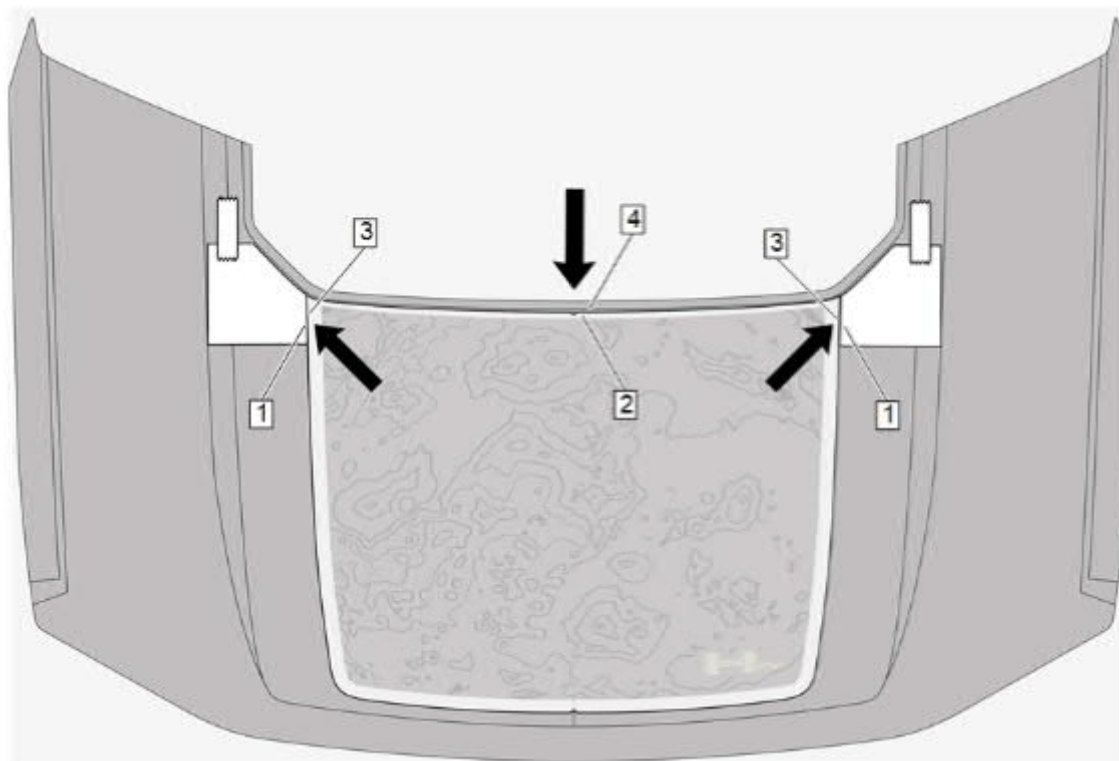

3. Place the decal onto the hood, aligning the outer rear edges of the premask carrier (3) to the alignment templates (1) while aligning the rear premask edge (2) to the rear edge of the hood panel (4) (not to the hood shroud). Reposition as necessary until aligned.

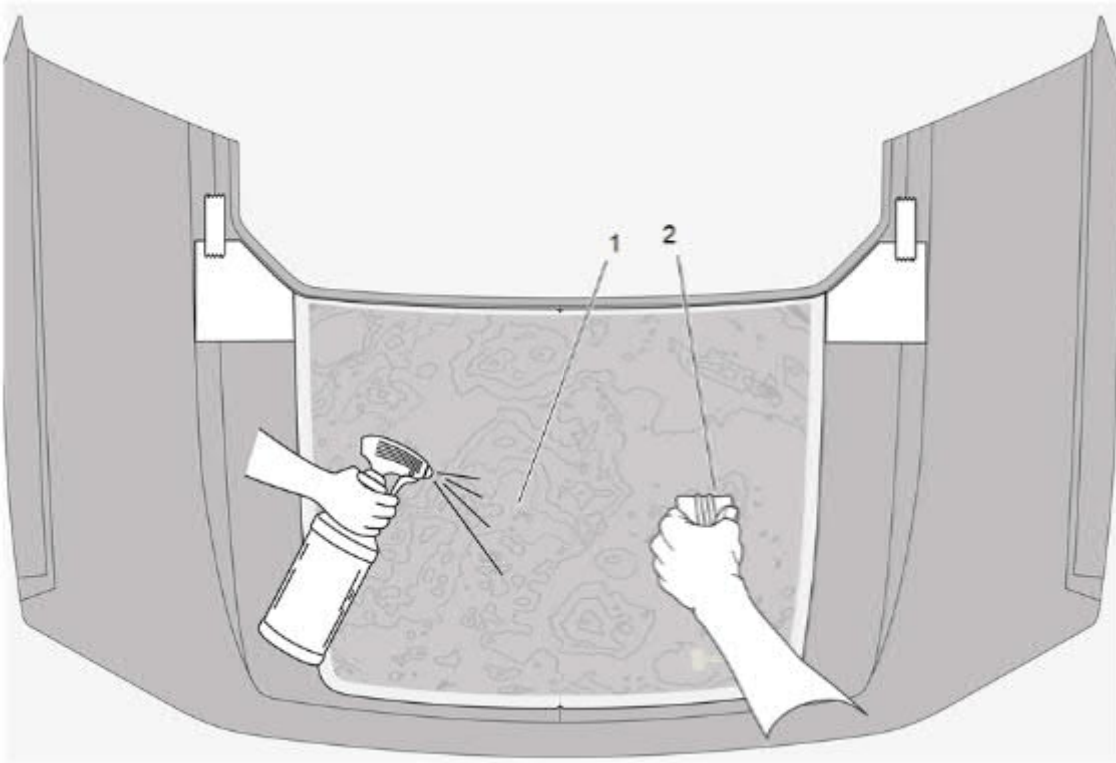

Note: Only use the included plastic squeegee to work the decals. Using the incorrect squeegee will damage the decals.

4. Spray surfactant onto the premask carrier (1) and firmly squeegee (2) into place.

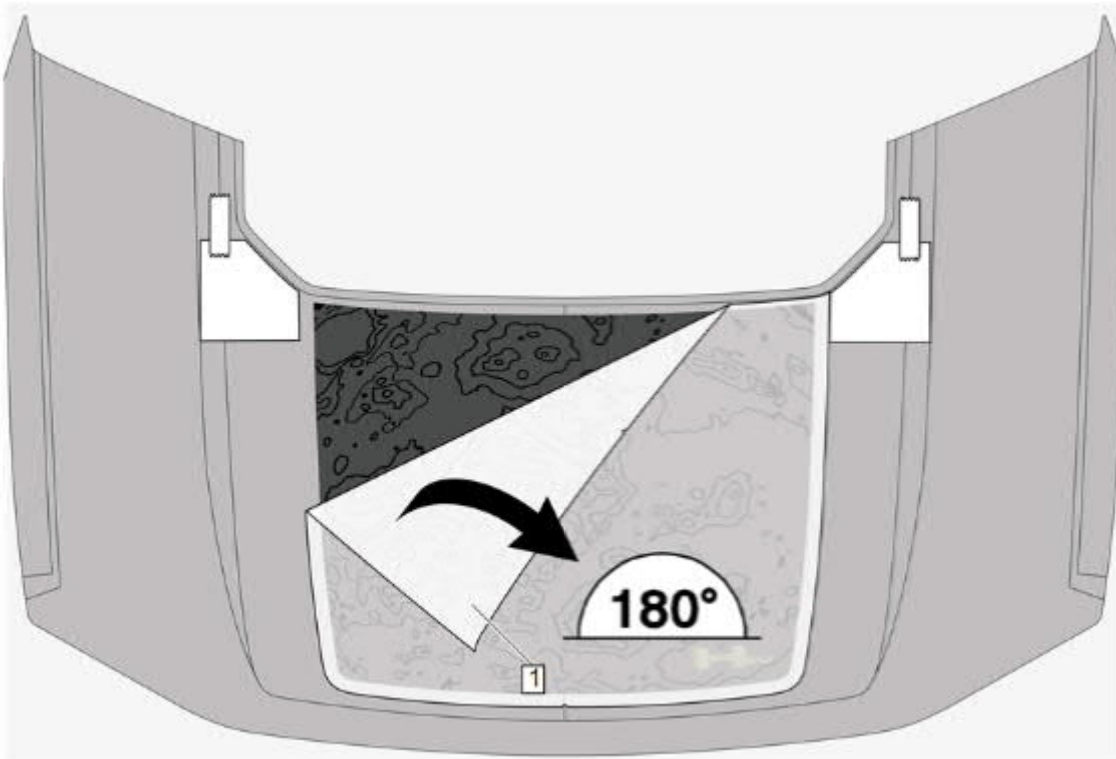

5. Carefully remove the premask carrier (1) by pulling it off at a 180 degree angle.

Note: The sewing needle must be inserted in the side of the bubble, not the top to prevent the sewing needle from breaking the paint and cause corrosion. See "Accessory Decal Installation Tips and Tricks" video for demonstration.

6. Inspect the decal for any bubbles and/or lifting. If necessary, cover the edge of the squeegee with a towel and re-press into place. If any bubbles cannot be removed, pierce the bubble with a sewing needle and press out the surfactant.

Outer "U" Hood Decal

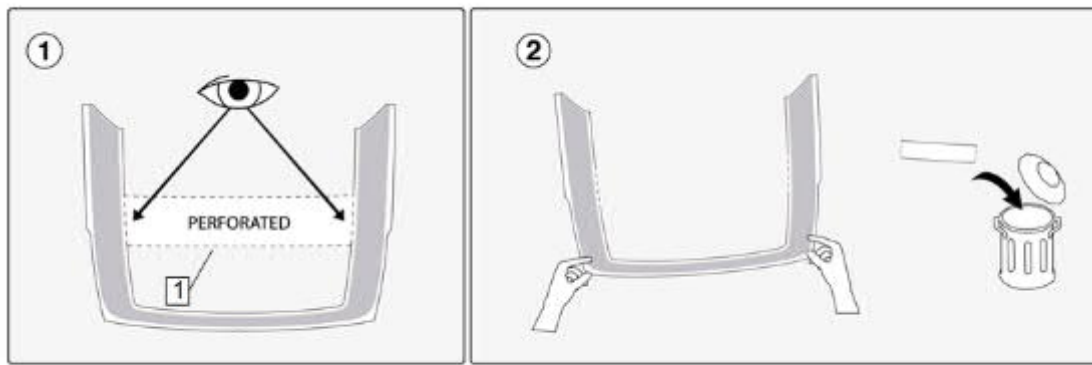

1. Separate the center portion of premask carrier and liner (1) from the "U" decal along the perforations. Discard this portion.

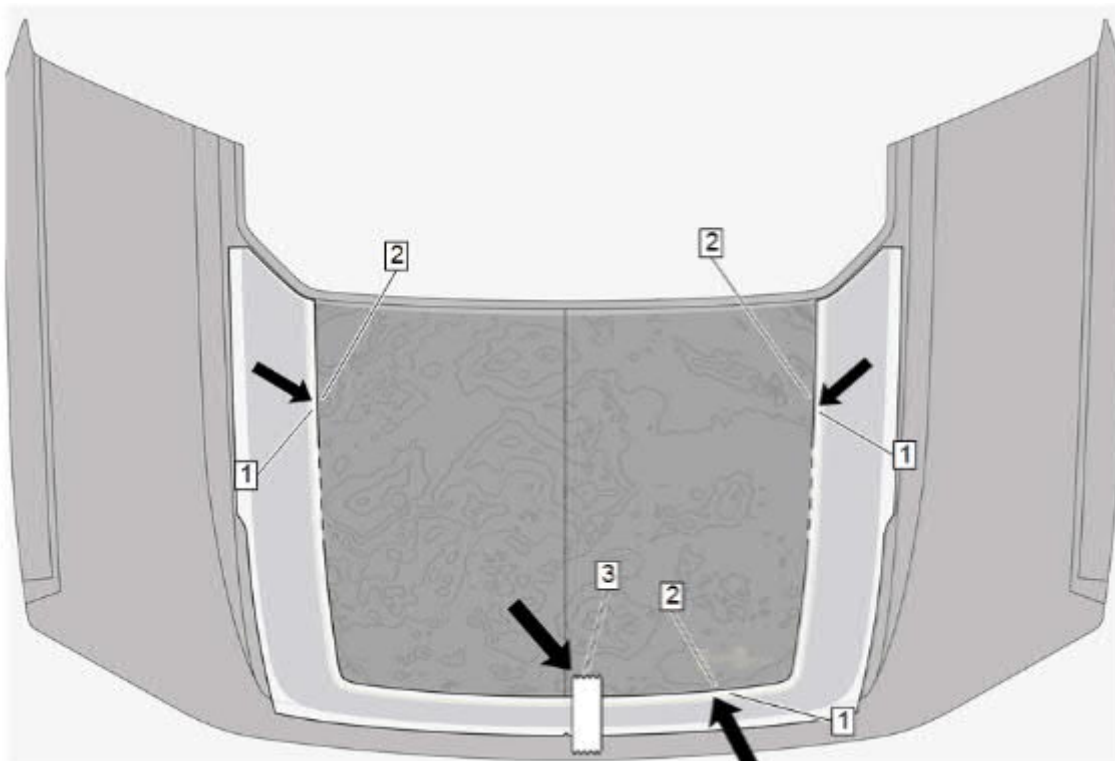

2. Align the inner premask carrier of the outer "U" portion (1) to the outer edges of the installed inner portion (2) (this should result in a consistent gap between the two decals). Use masking tape (3) to tape into place as shown.

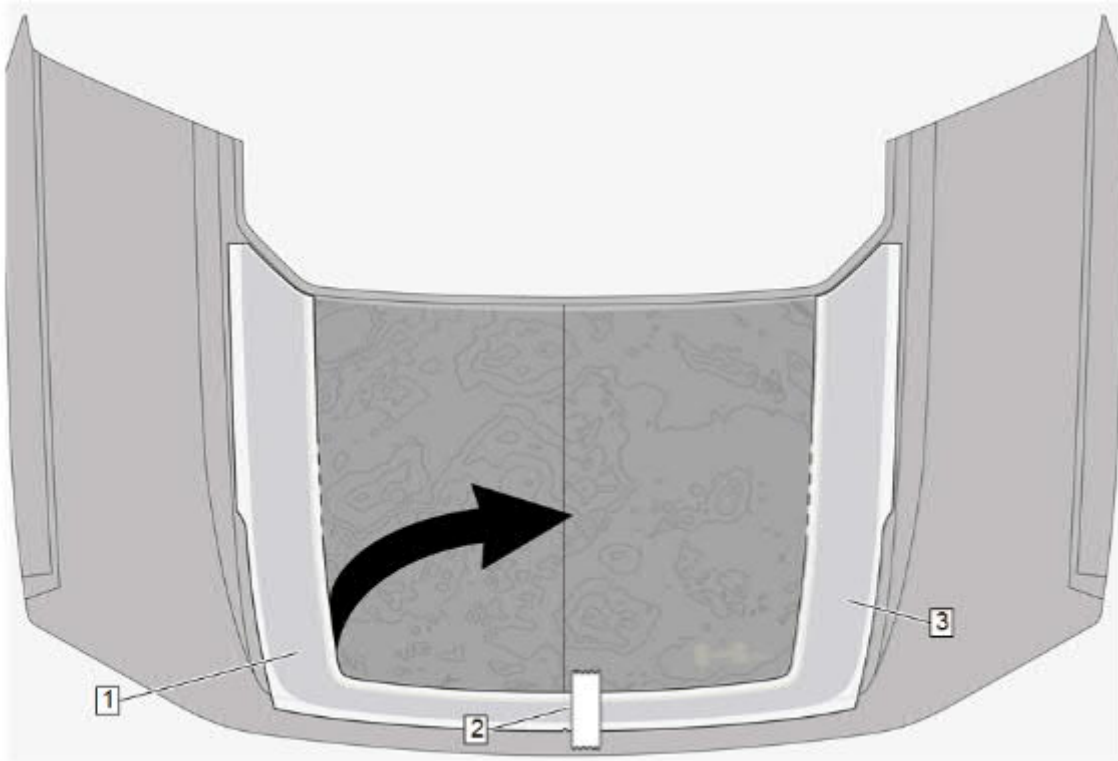

3. Carefully fold the passenger side portion (1) back to the masking tape (2) (do not press into place) and place temporarily on top of the driver's side decal (3).

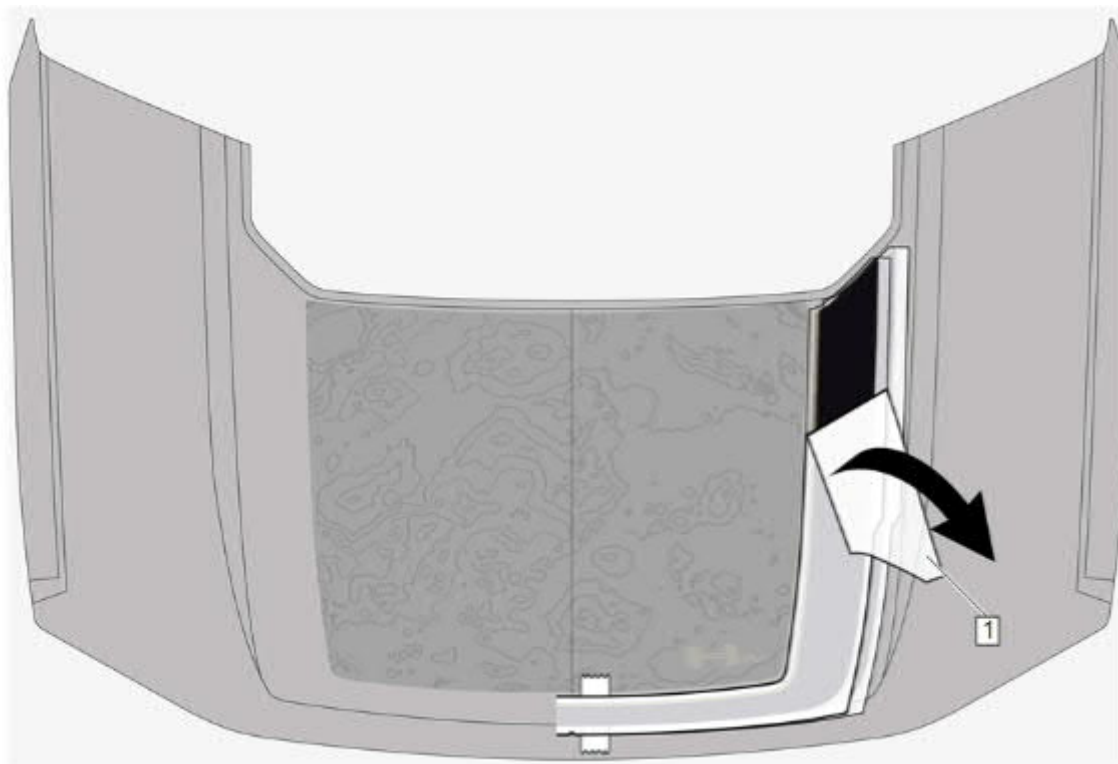

4. Remove the white release liner (1) from the "folded" portion of the decal.

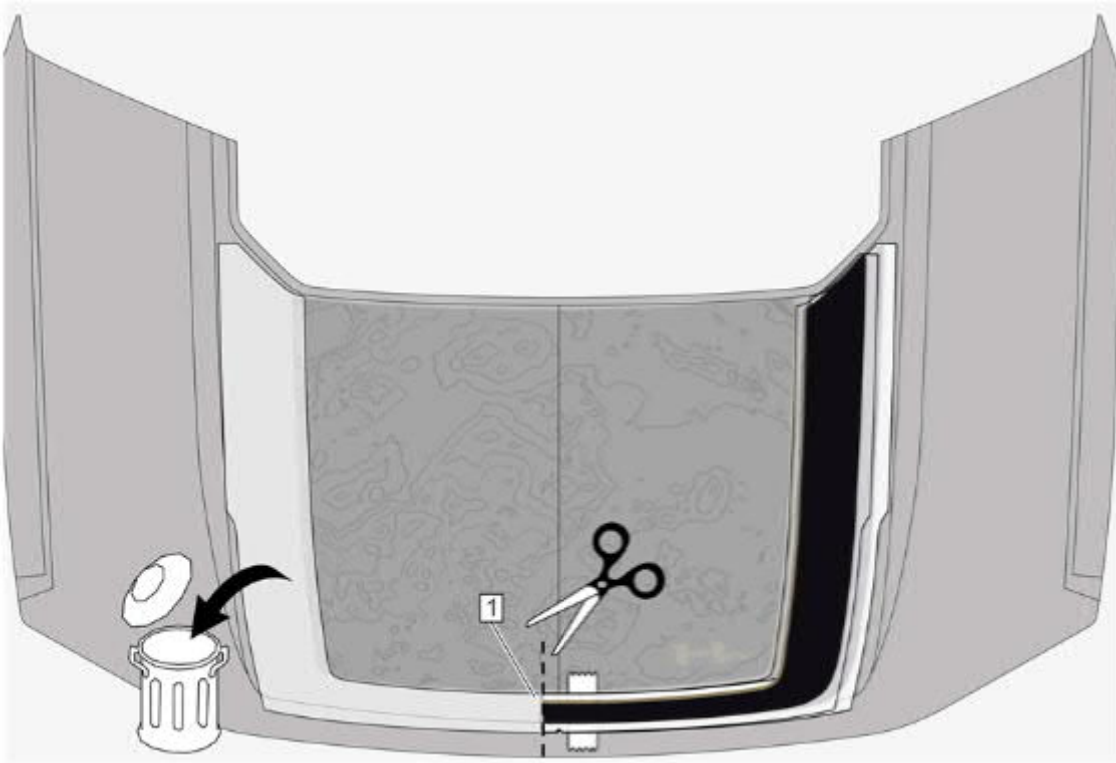

5. Trim this liner (1) with scissors.

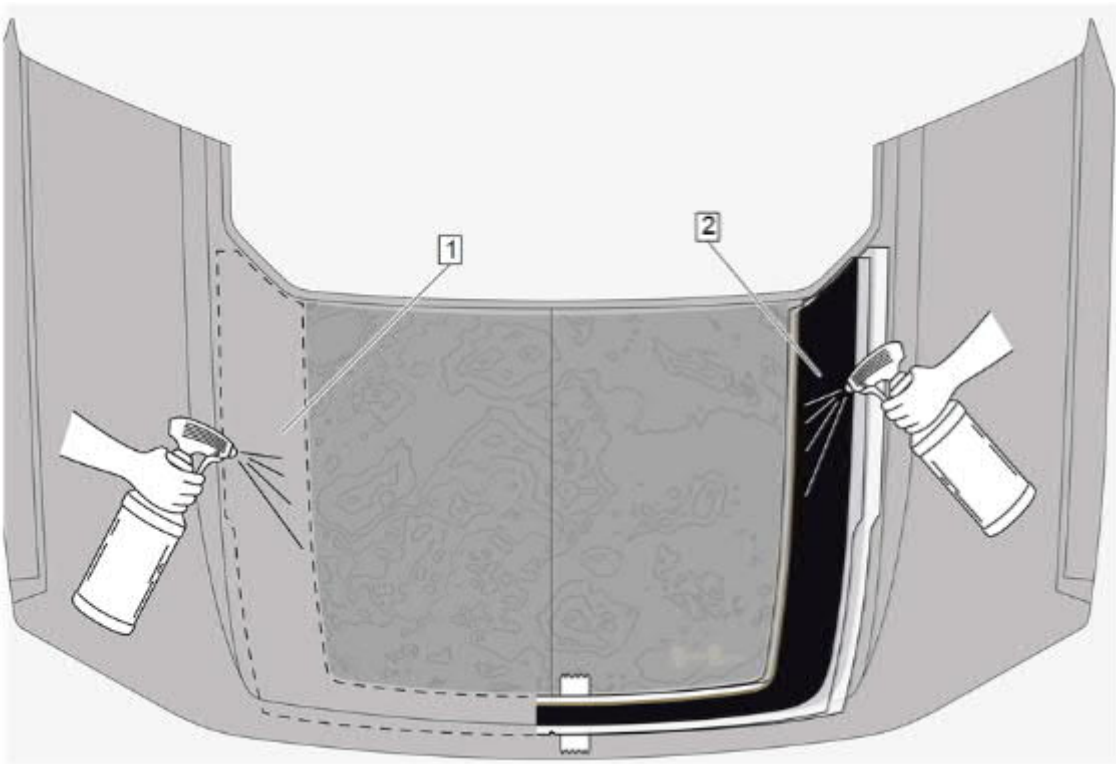

6. Spray a generous amount of surfactant onto the hood panel (1) and the exposed decal adhesive (2).

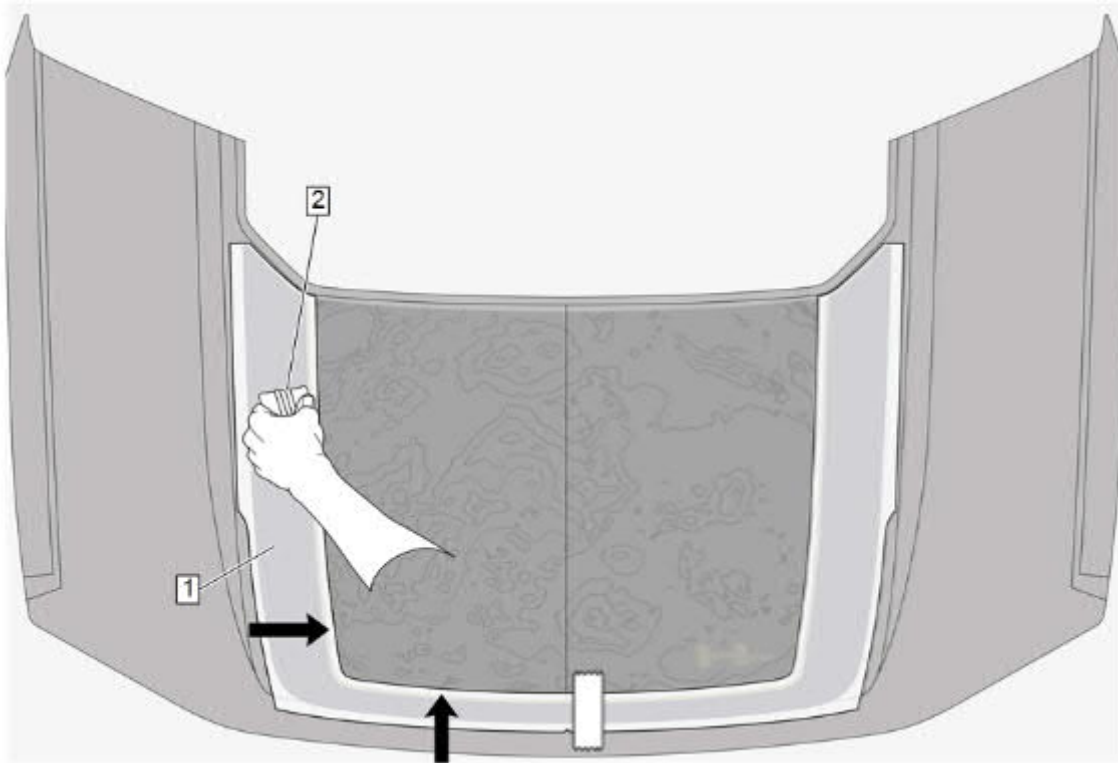

Note: Only use the included plastic squeegee to work the decals. Using the incorrect squeegee will damage the decals.

7. Place the decal (1) back into position and use the squeegee (2) to press the passenger side portion into place, while maintaining a consistent gap between the two decals.

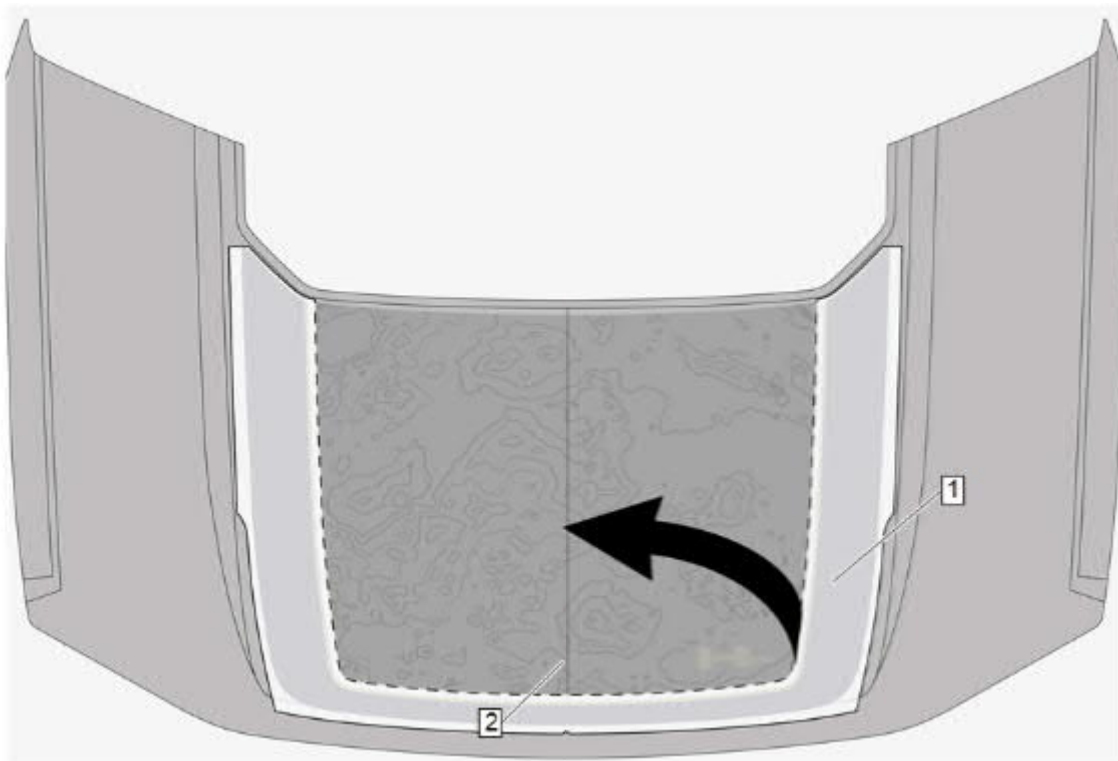

8. Remove the masking tape and carefully fold the driver's side of the decal (1) onto the passenger side up to the center point (2) where the decal is adhered. Do not press into place.

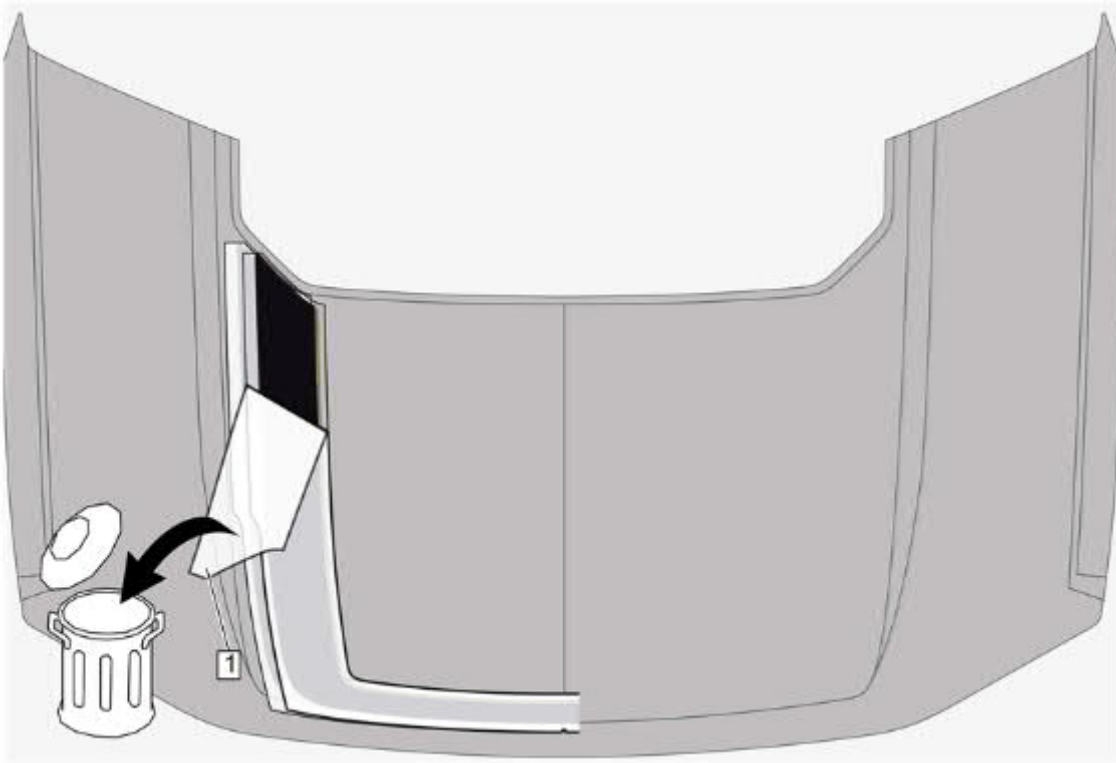

9. Remove the white release liner (1) from the “folded” portion of the decal.

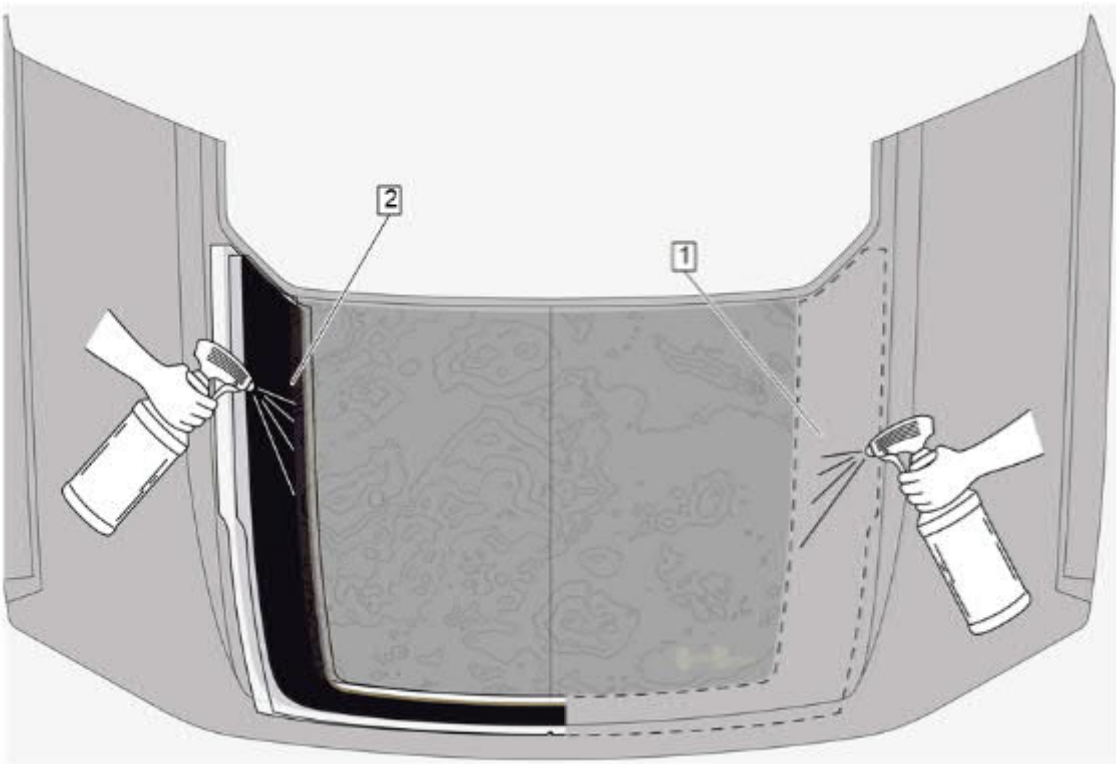

10. Spray a generous amount of surfactant onto the hood panel (1) and the exposed decal adhesive (2).

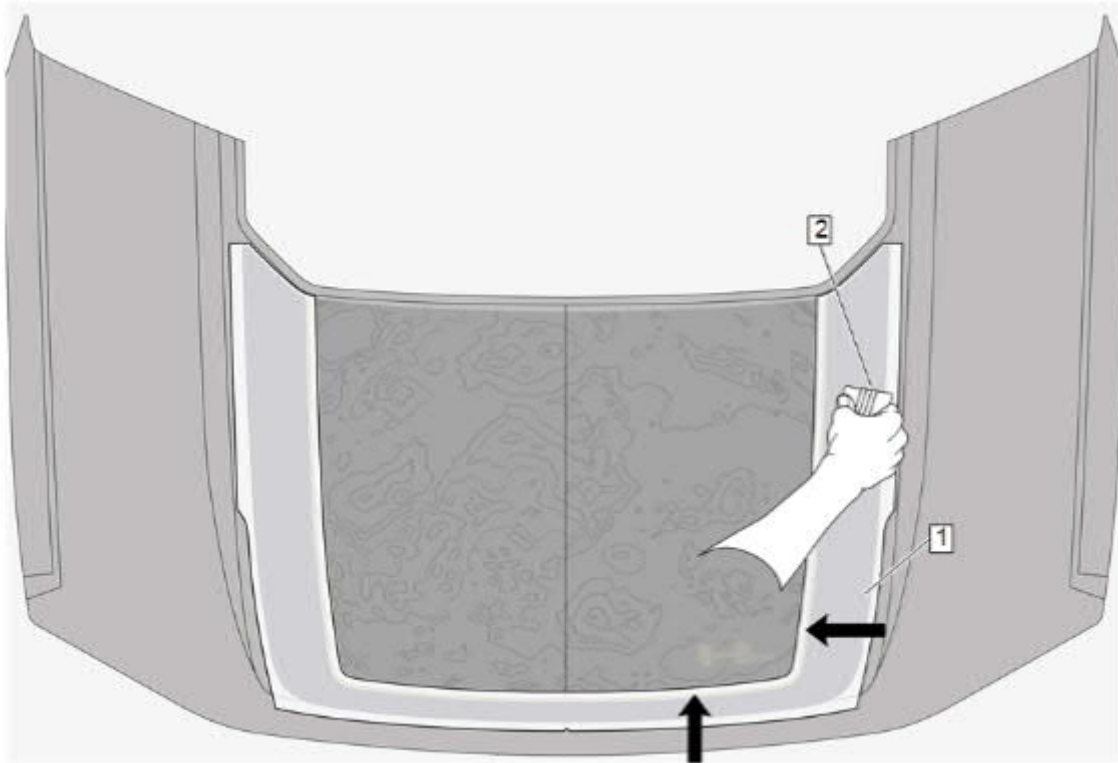

Note: Only use the included plastic squeegee to work the decals. Using the incorrect squeegee will damage the decals.

11. Place the driver's side portion (1) back into position and use the squeegee (2) to press into place.

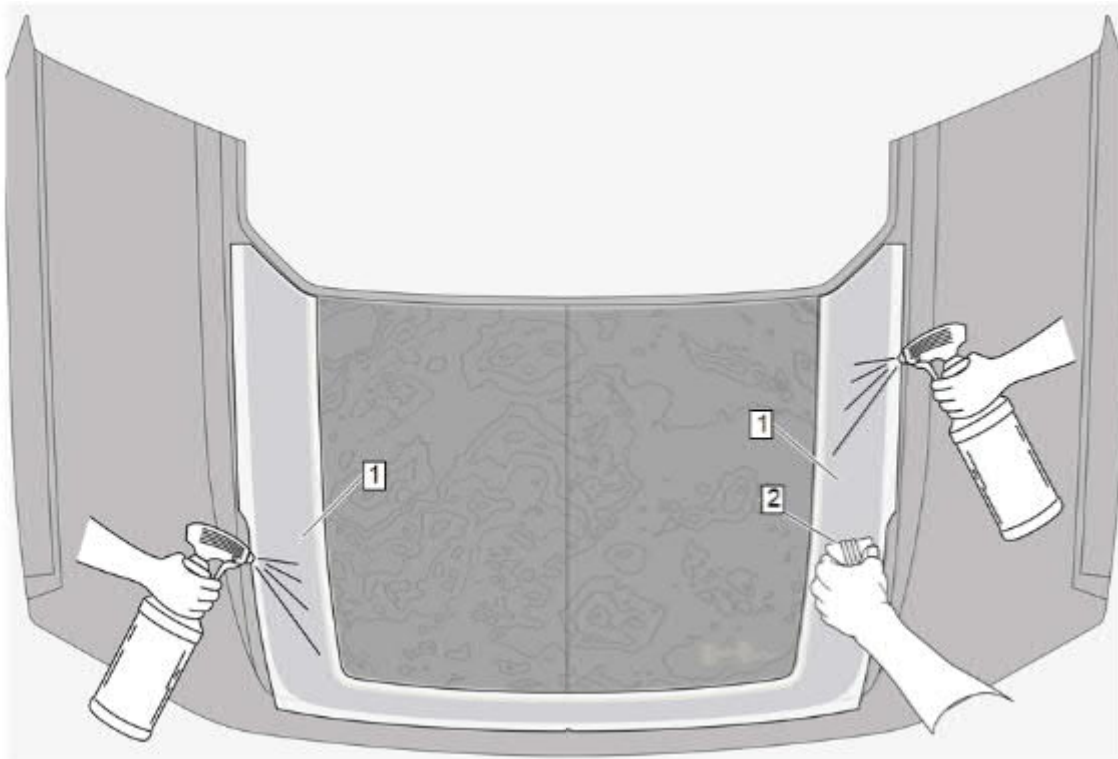

Note: Only use the included plastic squeegee to work the decals. Using the incorrect squeegee will damage the decals.

12. Spray a generous amount of surfactant onto the premask carrier surface (1) and re-squeegee (2).

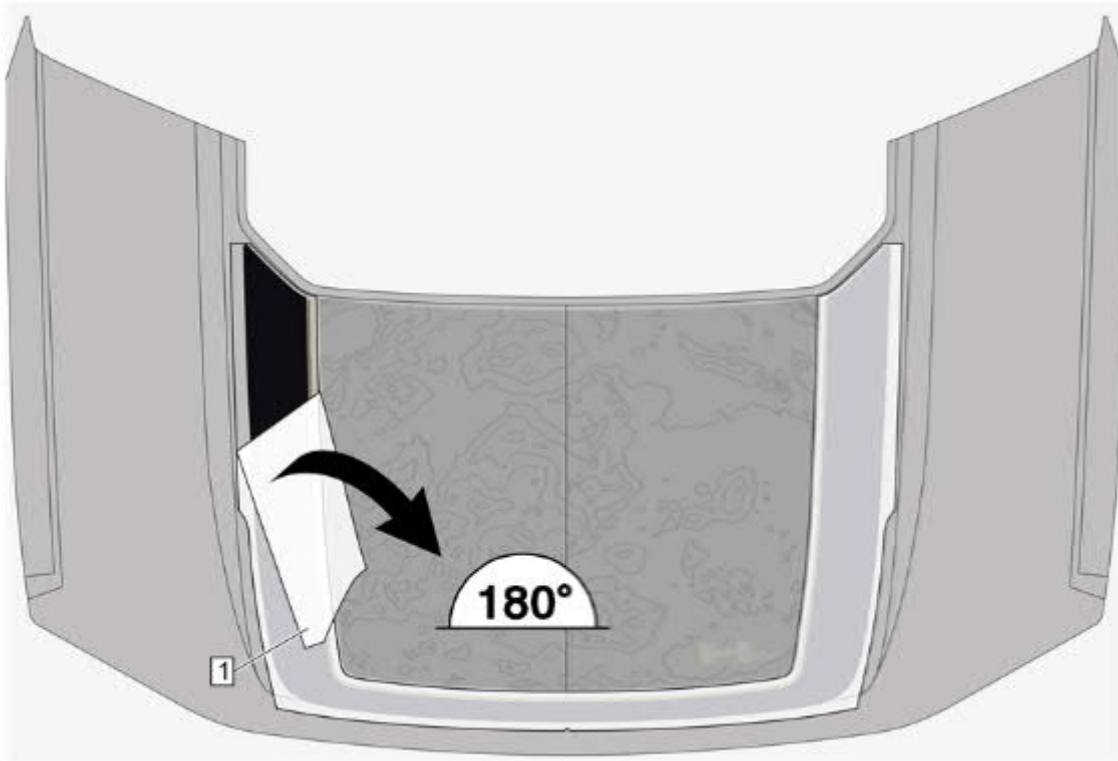

13. Carefully remove the premask carrier (1) by pulling it off at a 180 degree angle.

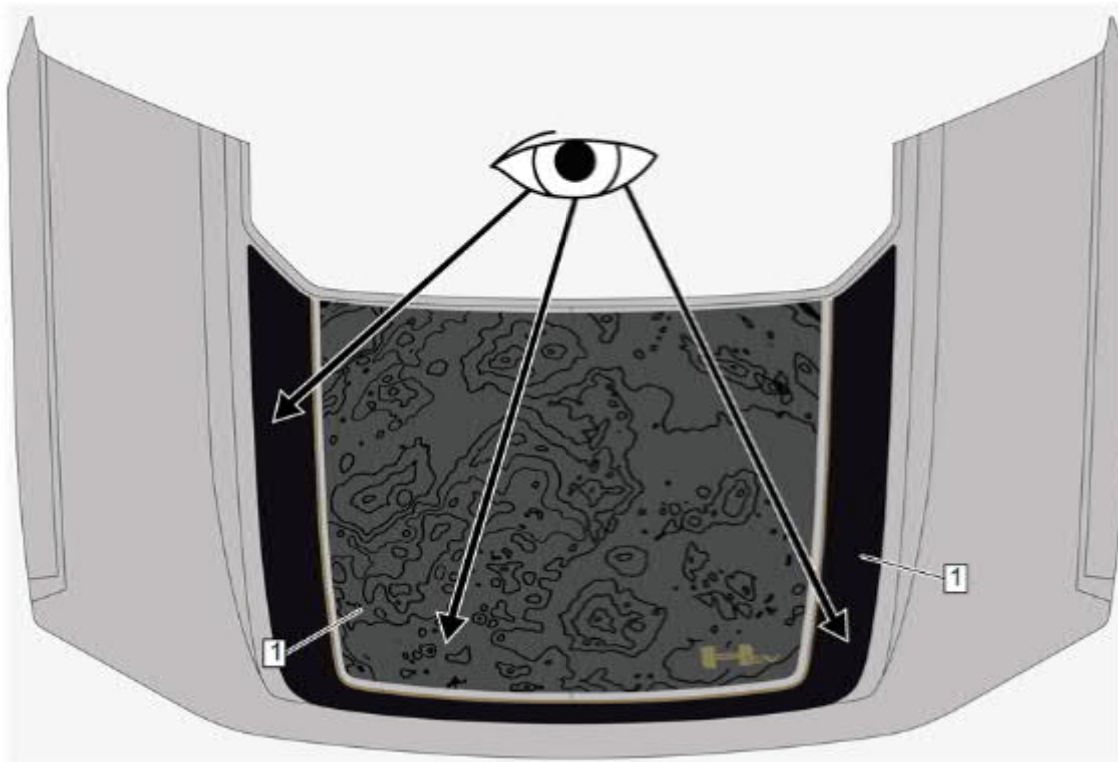

Note: The sewing needle must be inserted in the side of the bubble, not the top to prevent the sewing needle from breaking the paint and cause corrosion. See "Accessory Decal Installation Tips and Tricks" video for demonstration.

14. Inspect the decal (1) for any bubbles and/or lifting. If necessary, cover the edge of the squeegee with a towel and re-press into place. If any bubbles cannot be removed, pierce the bubble with a sewing needle and press out the surfactant.