

# Rear Closure Center with License Plate Lamp Applique Package Installation

## Installation Instructions Part Number

85004547

### Kit Contents

Qty	Description
1	Rear Closure Center Applique
1	Installation Instructions

### Tools Required

Small flat bladed plastic trim tool

### Procedure

#### Removal

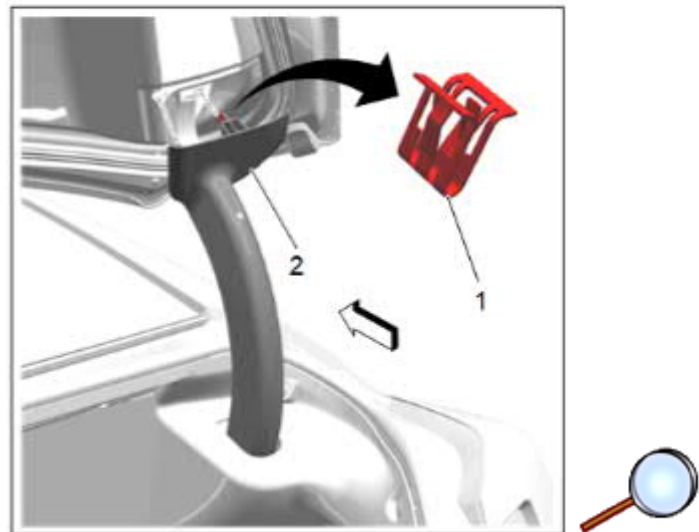
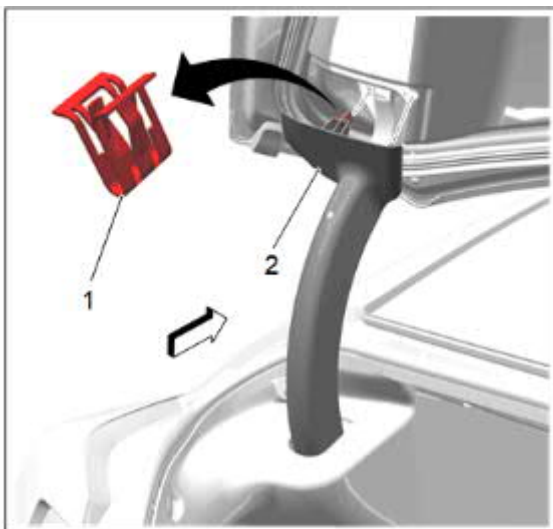

1. Disengage the retaining clip (1) and remove the upper portion of rear compartment lid hinge cover (2) from rear compartment lid.

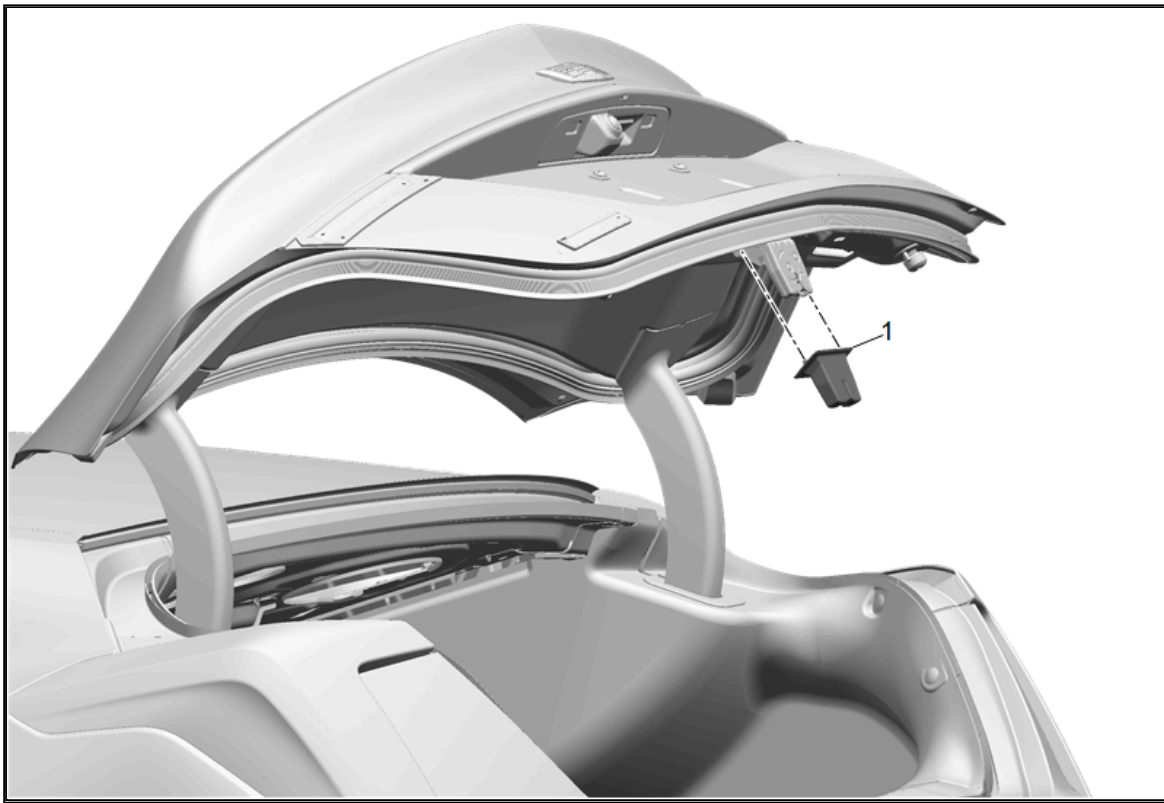

2. Using a small flat bladed plastic trim tool, pull and release the rear compartment lid latch cover (1).

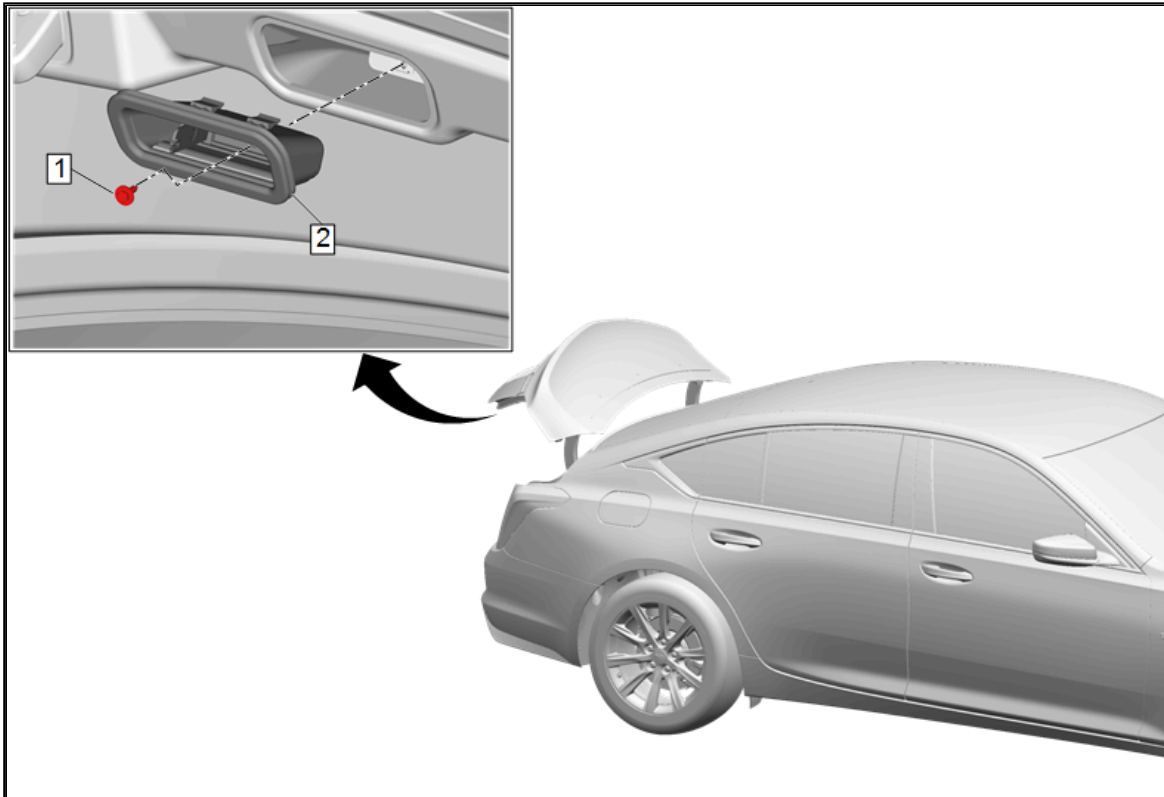

3. Using a small flat bladed plastic trim tool, open the integral handle cover to access bolt (1). Remove bolt and rear compartment lid inside handle (2).

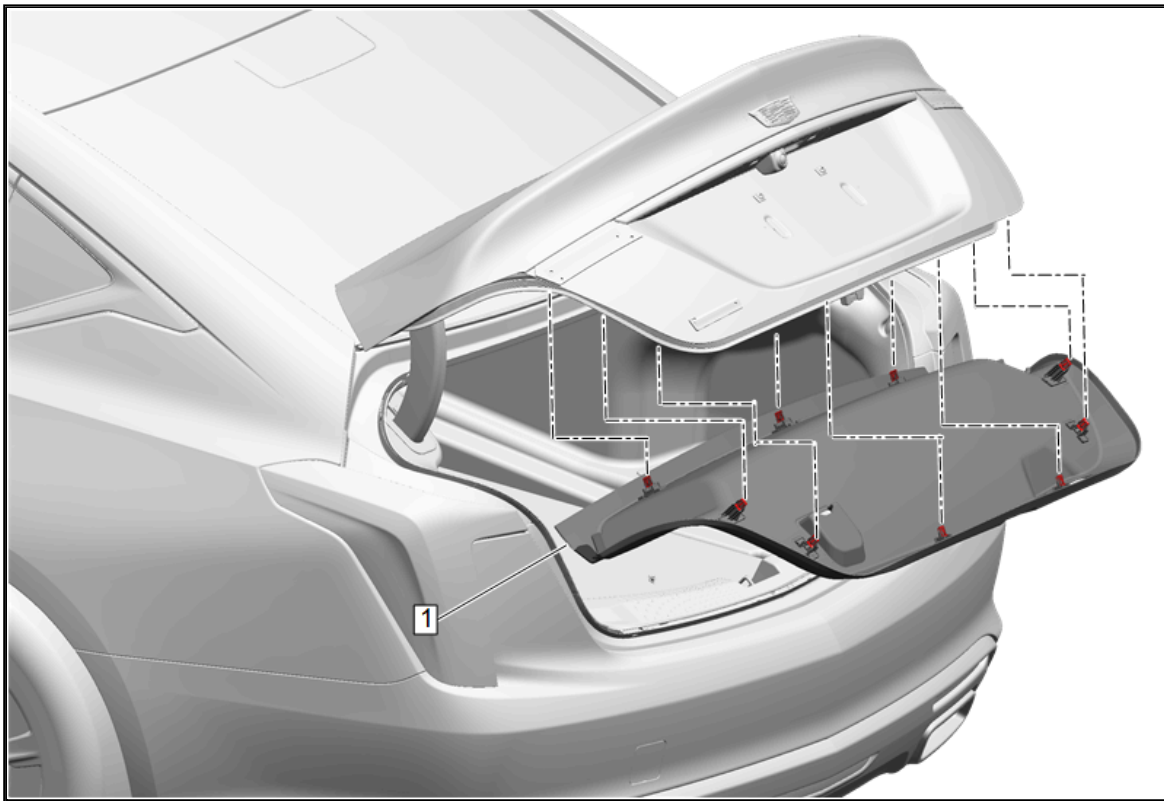

**Note:** Ensure the auxiliary rear compartment latch release handle is routed through the rear compartment lid inner panel trim.

4. Using a flat bladed plastic trim tool, disengage the push-in retainers from the sheet metal and remove the rear compartment lid inner trim panel (1).

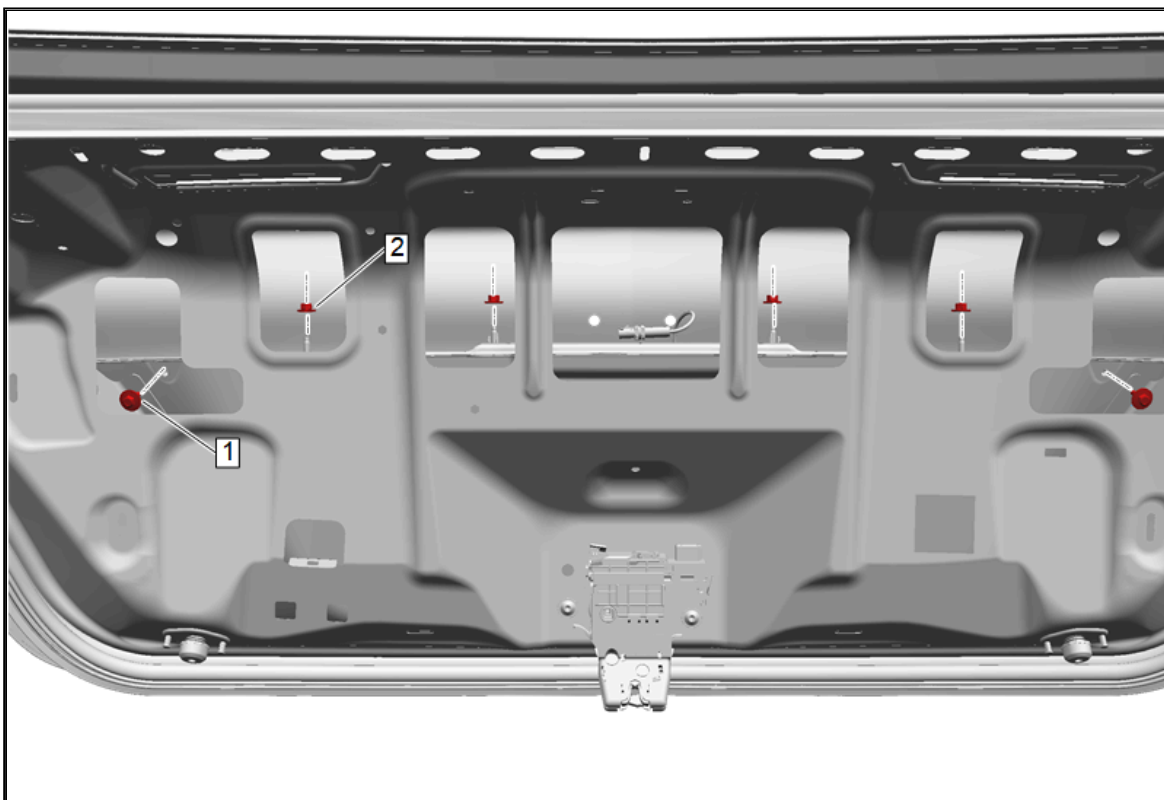

5. Rear Closure Center Applique Bolt (1) » Remove [2x]
6. Rear Closure Center Applique Nut (2) » Remove [4x]
7. Disconnect the electrical connectors.

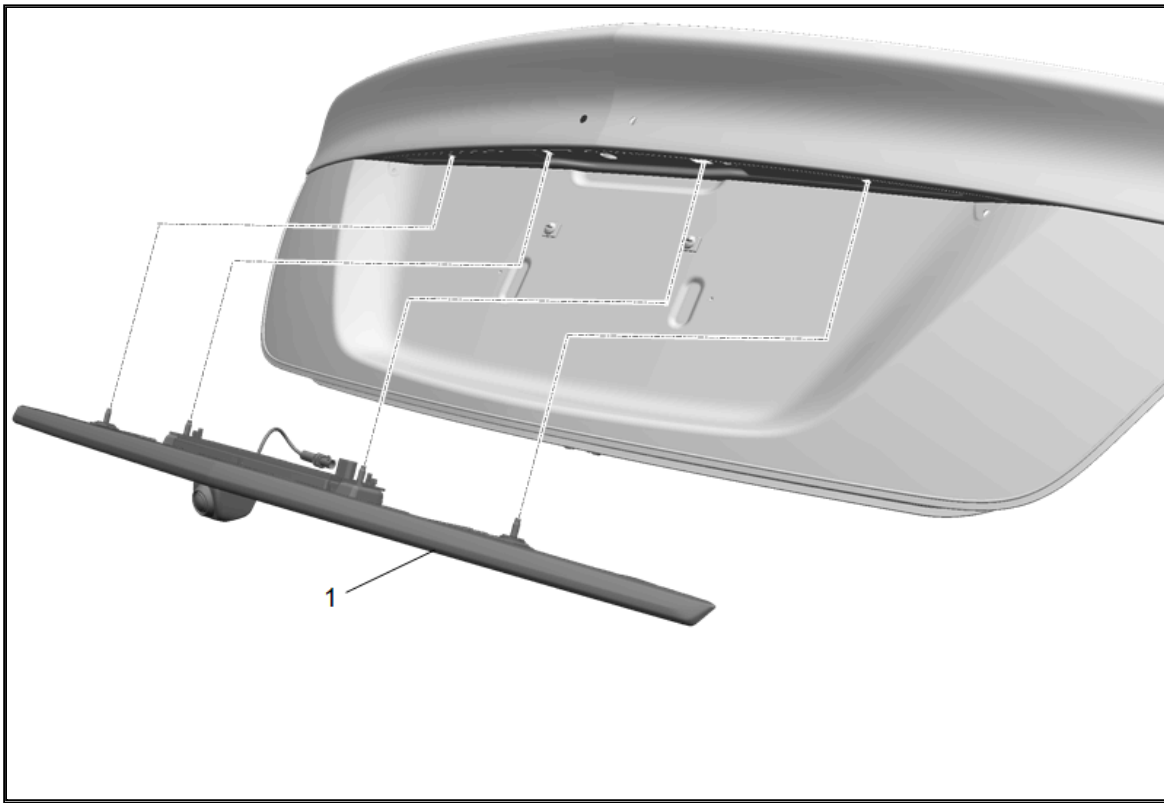

8. Rear Closure Center Applique (1) » Remove

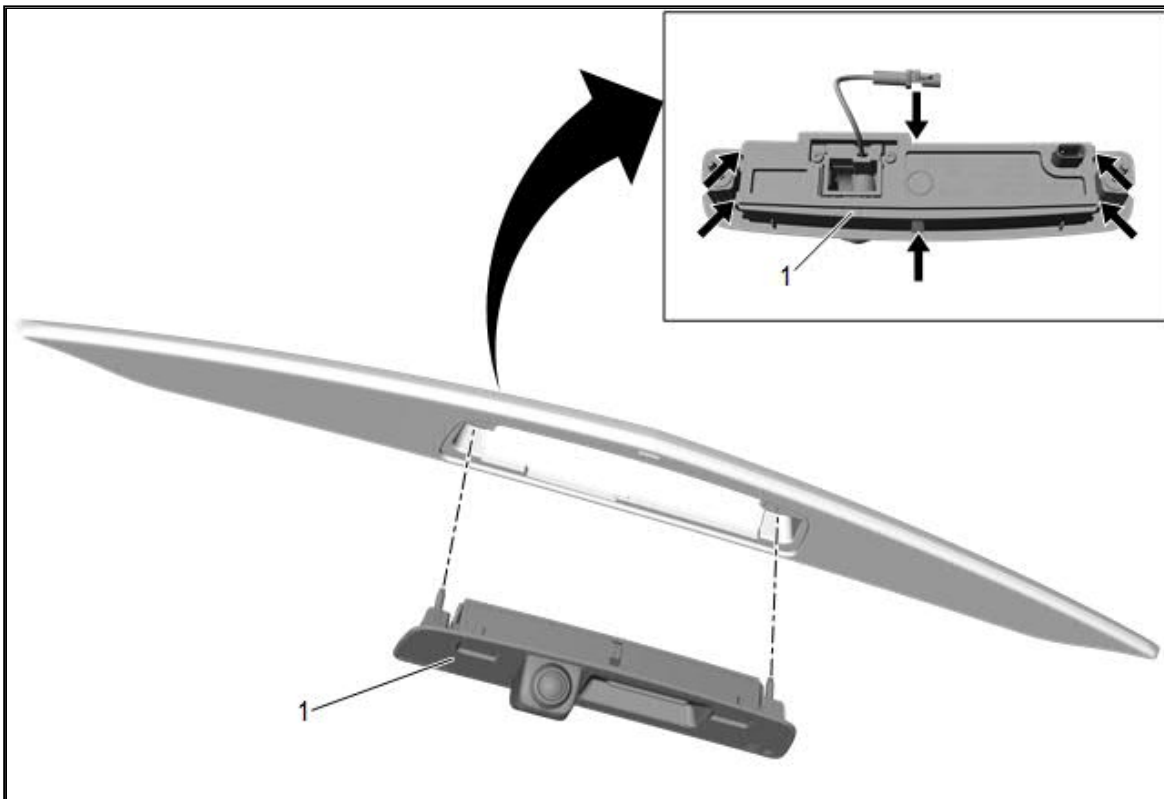

9. Release the retaining tabs and remove the rear license lamp module (1) from rear closure center applique.

### Installation

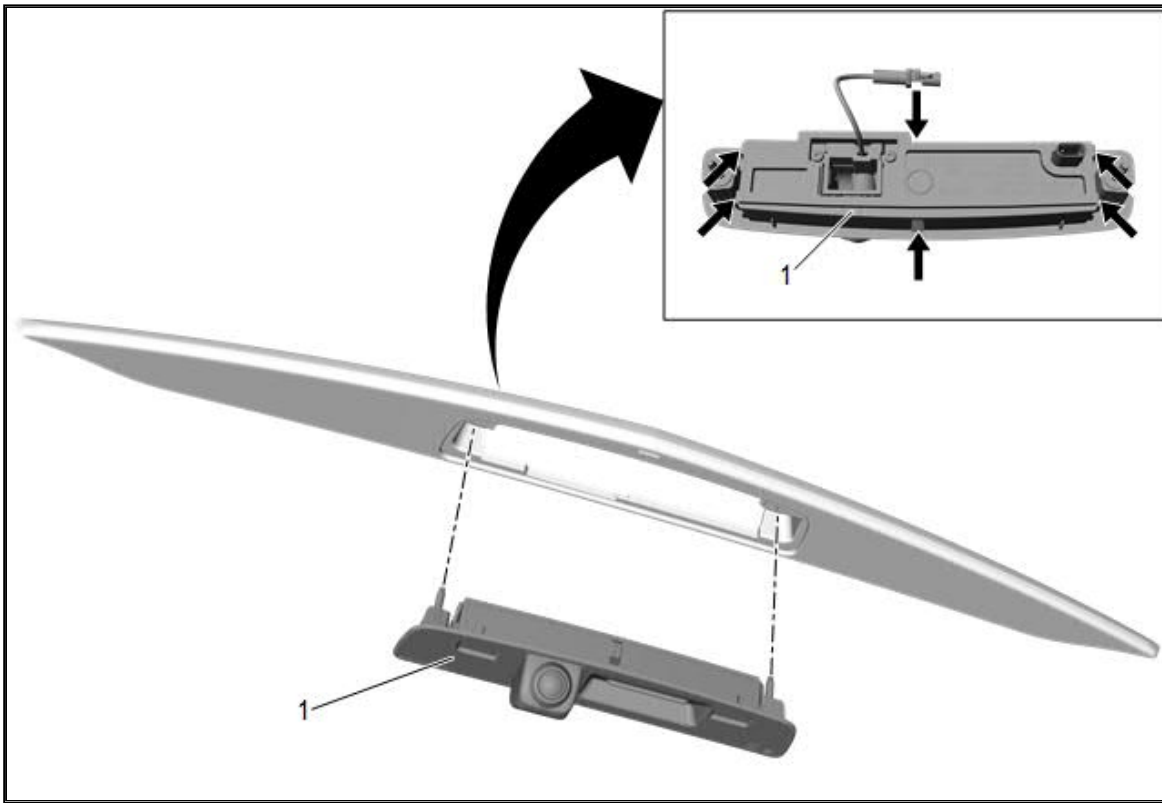

1. Install the rear license lamp module (1) to new rear closure center applique making sure to engage the retaining tabs.

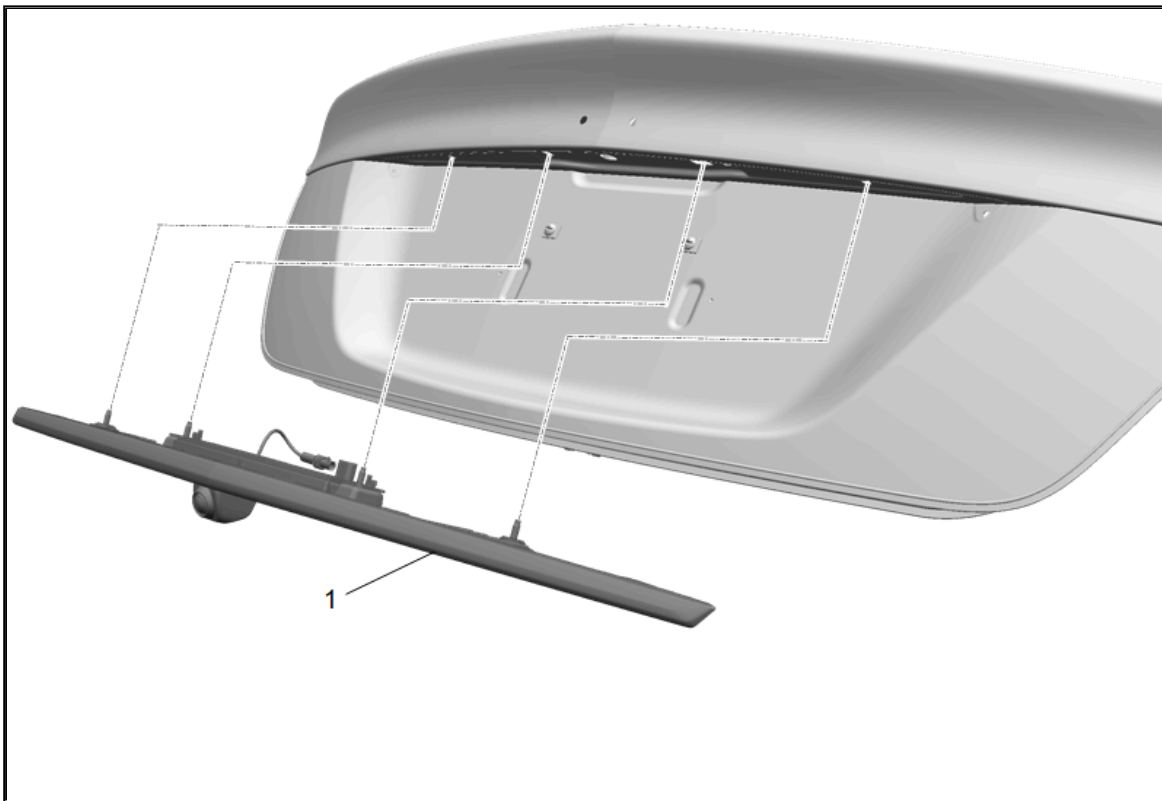

2. Rear Closure Center Applique (1) » Install

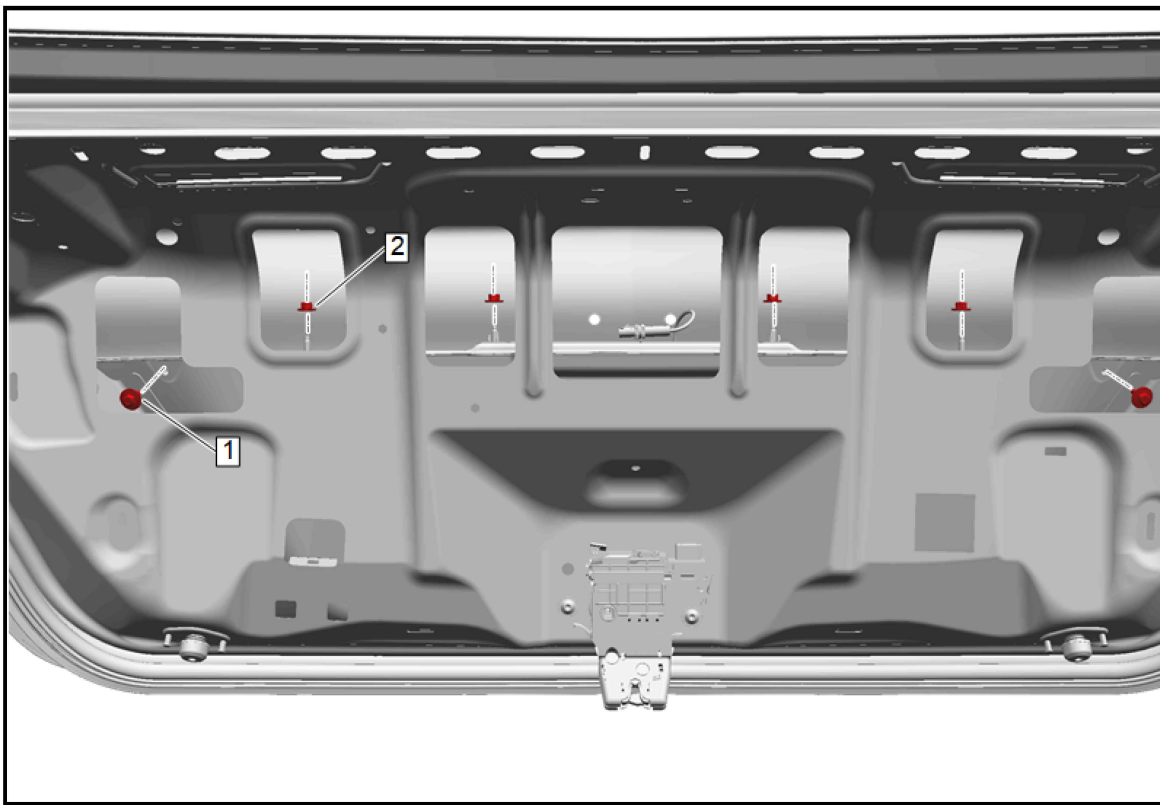

**Caution:** Use the correct fastener in the correct location. Replacement fasteners must be the correct part number for that application. Fasteners requiring replacement or fasteners requiring the use of thread locking compound or sealant are identified in the service procedure. Do not use paints, lubricants, or corrosion inhibitors on fasteners or fastener joint surfaces unless specified. These coatings affect fastener torque and joint clamping force and may damage the fastener. Use the correct tightening sequence and specifications when installing fasteners in order to avoid damage to parts and systems.

3. Rear Closure Center Applique Bolt (1) » Install and tighten [2x] **4.7 N.m (42 lb in)**
4. Rear Closure Center Applique Nut (2) » Install and tighten [4x] **4.7 N.m (42 lb in)**
5. Connect the electrical connectors.

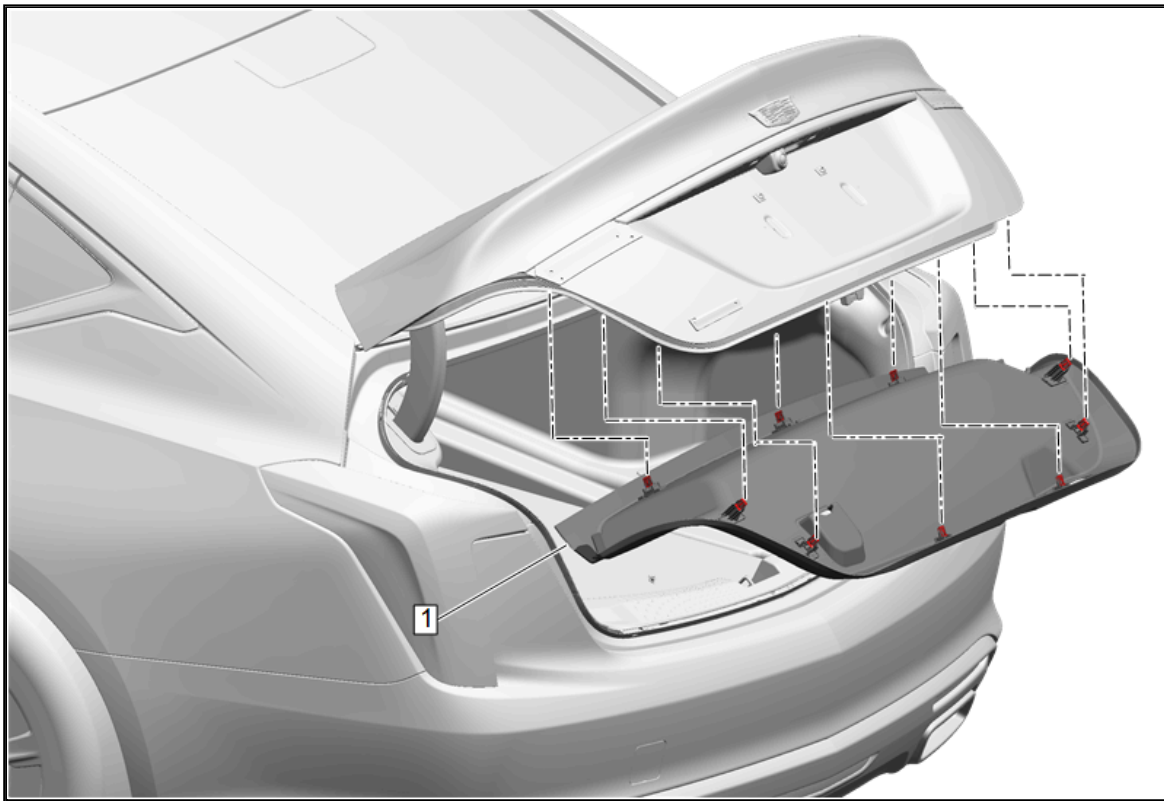

**Note:** Ensure the auxiliary rear compartment latch release handle is routed through the rear compartment lid inner panel trim.

6. Install the rear compartment lid inner trim panel (1) to rear compartment lid making sure to engage the push-in retainers to the sheet metal.

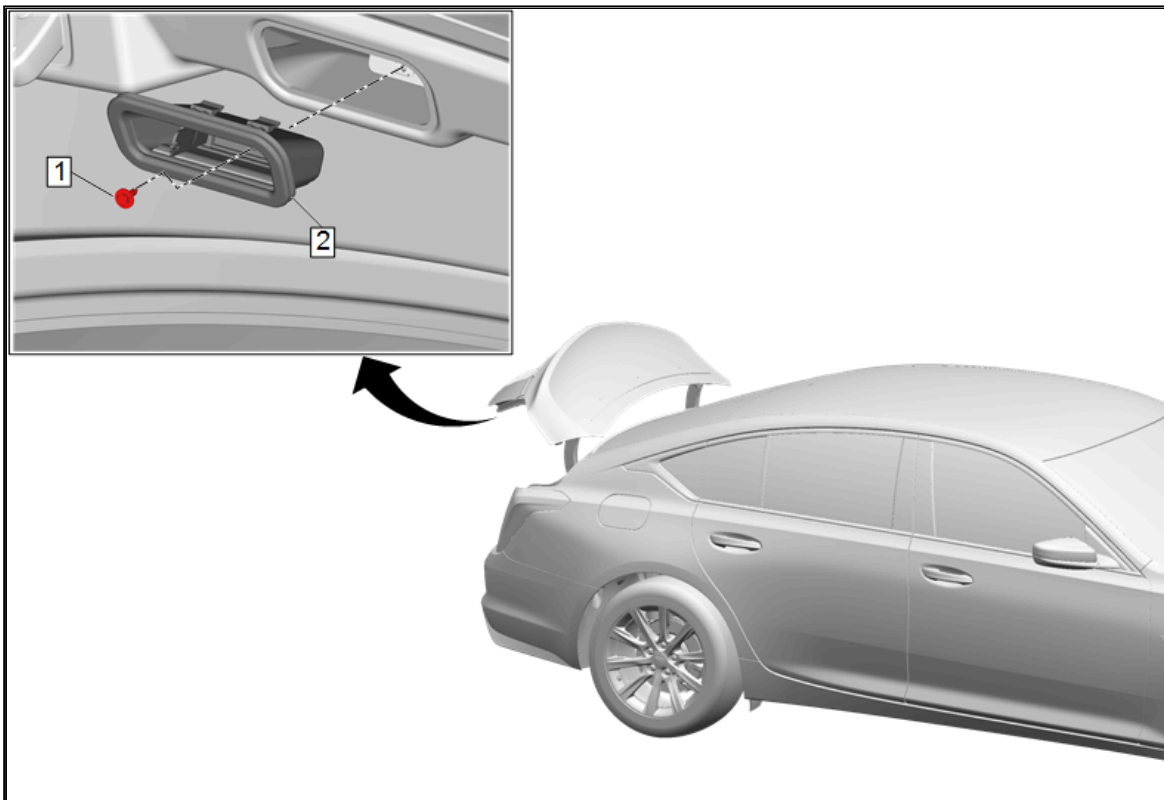

7. Install the rear compartment lid inside handle (2) to rear compartment lid inner trim and secure with bolt (1). Tighten bolt to 2.5 N.m (22 lb in)

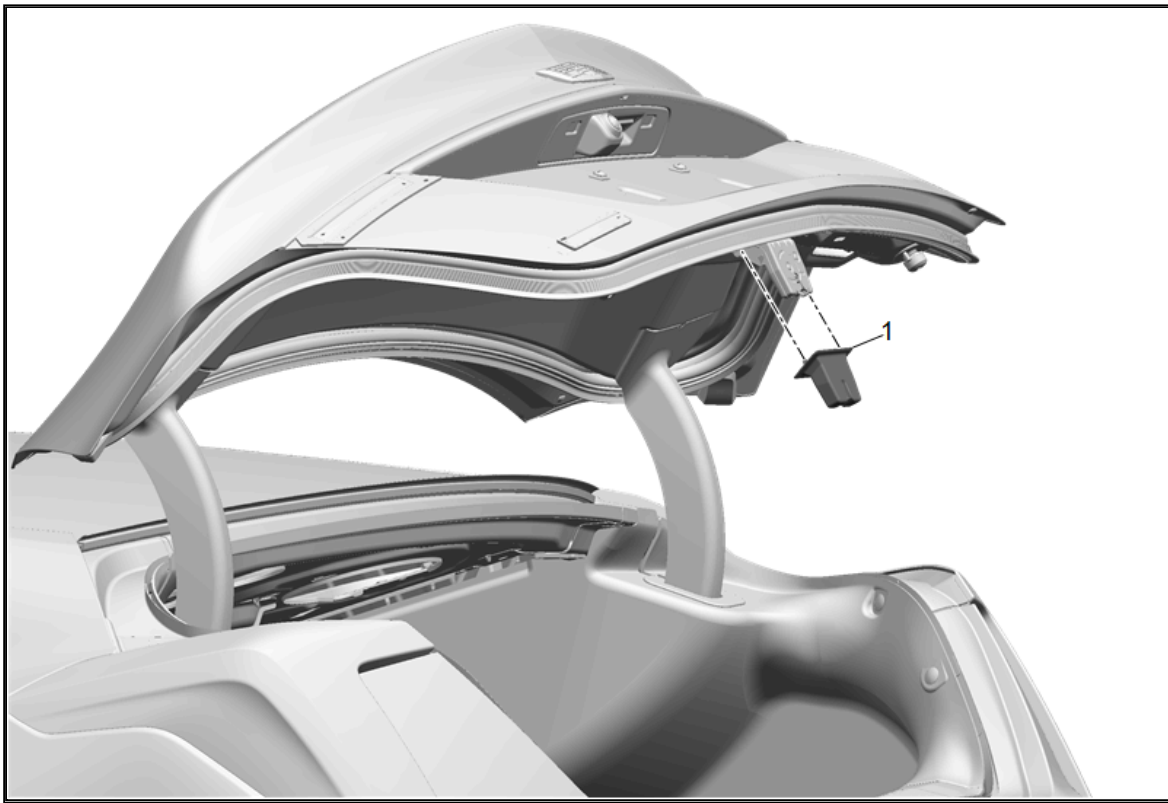

8. Install the rear compartment lid latch cover (1) to latch.

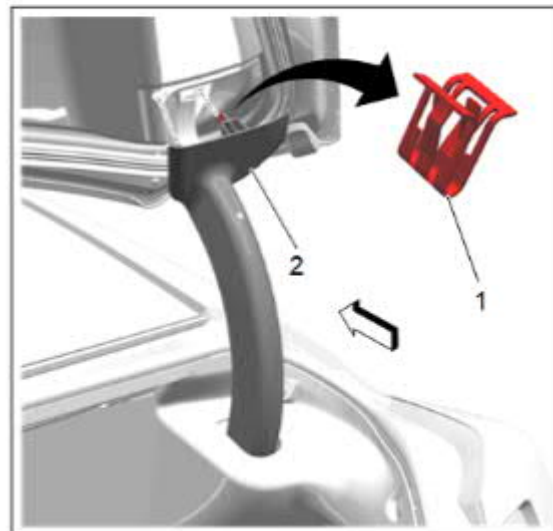
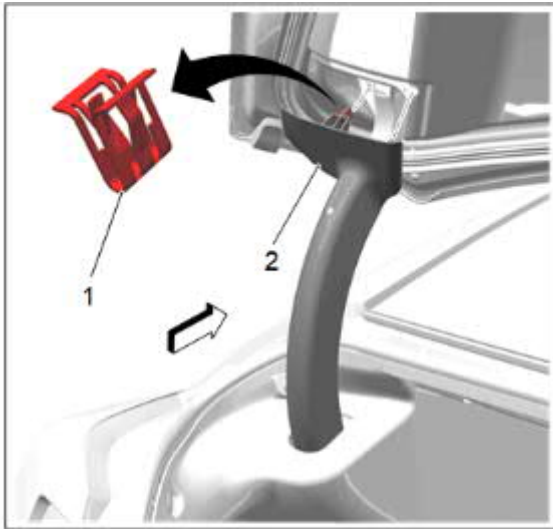

9. Position the upper portion of rear compartment lid hinge cover (2) to rear compartment lid and engage retaining clip (1).

10. Perform the camera calibration procedure, if necessary. Refer to [Video Processing Control Module Calibration](#) in Vehicle Service Manual.