

# Front Fender Mud Flap Package Installation

**Table 1:** [Kit Contents RPO \(VRV\)](#)

**Table 2:** [Kit Contents RPO \(VQK\)](#)

## Installation Instructions Part Number

85125917

Please read instructions thoroughly before starting.

### Kit Contents RPO (VRV)

Qty	Description
1	Left Hand Splash Guard
1	Right Hand Splash Guard
1	Left Hand Bracket
1	Right Hand Bracket
2	Screw with Washer
2	Short Screw
2	Long Screw
4	Washer
4	Rivet
6	U-Nut
1	Instruction Sheet

### Tools Required

- T15 Torx Screwdriver
- 5mm (13/64") Drill Bit/Drill
- Rivet Gun
- Awl
- Clean Cloth/Rag
- Isopropyl Alcohol

### Procedure RPO (VRV)

1. Remove the front wheel and tire assembly. Refer to [Tire and Wheel Removal and Installation](#) in Vehicle Service Manual.
2. Clean and degrease body panel where splash guards are to be located.
3. Using isopropyl alcohol, clean area where tape will contact body panel.

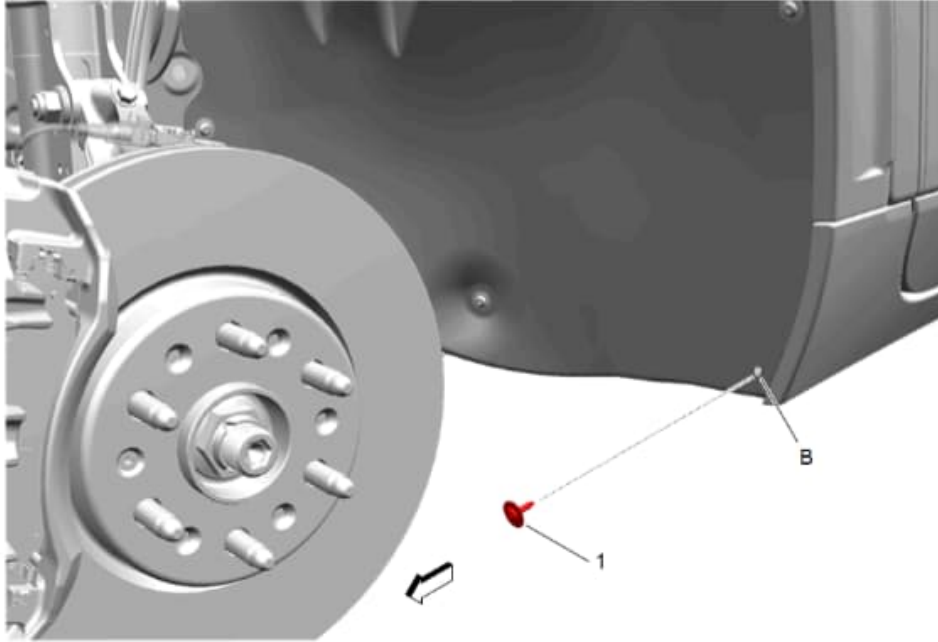

4. Remove existing screw (1) at location **(B)** and retain screw.

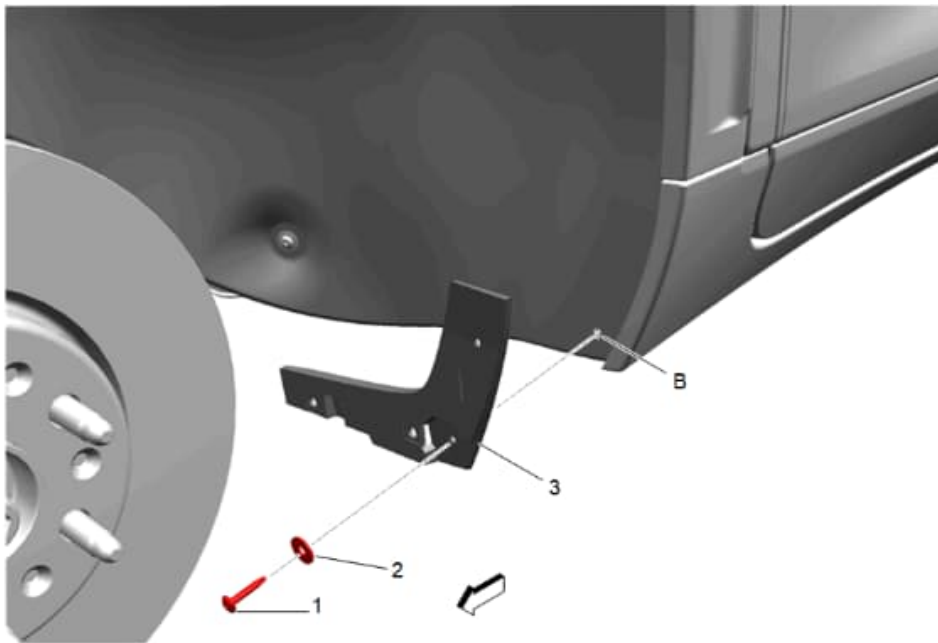

**Caution:** Use the correct fastener in the correct location. Replacement fasteners must be the correct part number for that application. Fasteners requiring replacement or fasteners requiring the use of thread locking compound or sealant are identified in the service procedure. Do not use paints, lubricants, or corrosion inhibitors on fasteners or fastener joint surfaces unless specified. These coatings affect fastener torque and joint clamping force and may damage the fastener. Use the correct tightening sequence and specifications when installing fasteners in order to avoid damage to parts and systems.

5. Install bracket (3) to the vehicle with short screw (1) and washer (2) at location **(B)**.

**Tighten**

Tighten screw to 3.0 N.m (2.0 lb ft)

**Caution:** Always check size and position of all holes before drilling. Failing to do so may cause damage to the vehicle, misalignment of components or the inability to install the accessory.

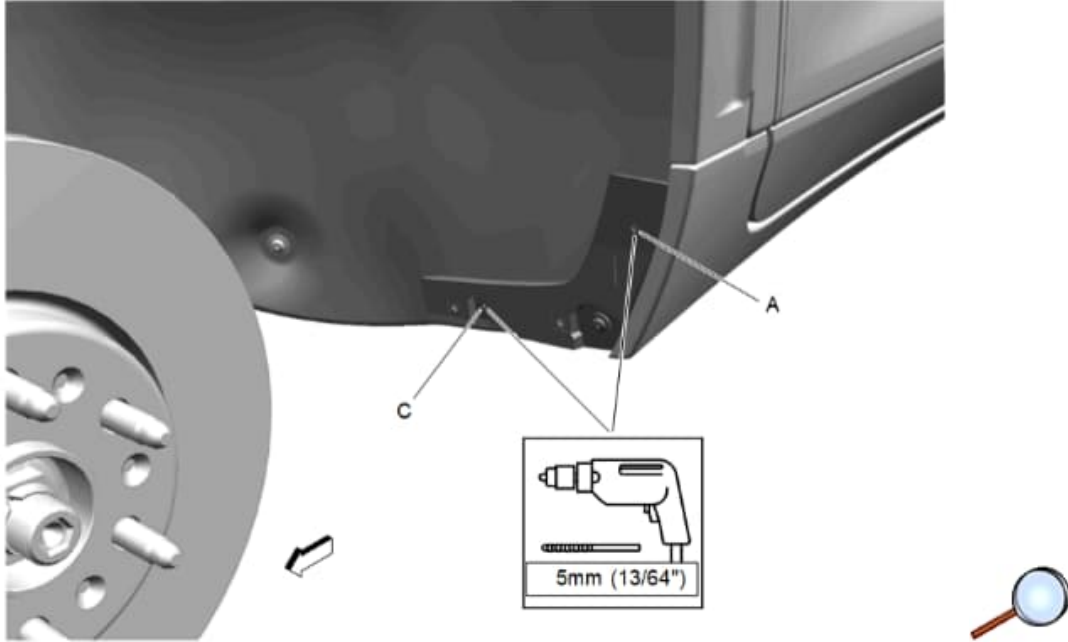

6. While holding the bracket firmly to the vehicle, carefully drill a 5mm (13/64") hole at location **(A)** and **(C)**.

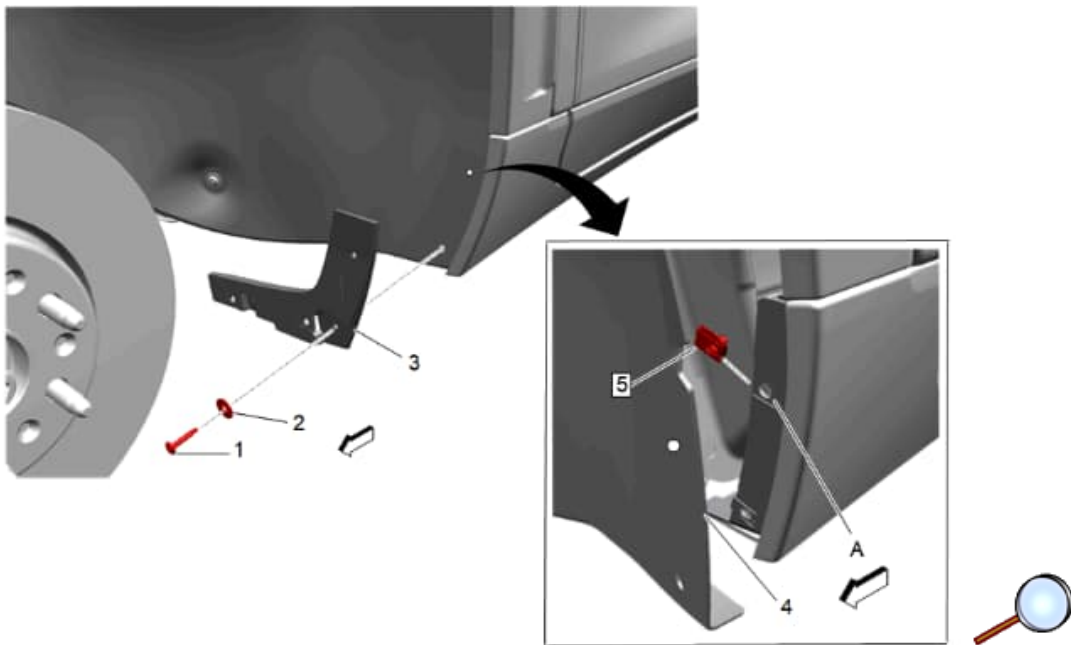

7. Remove the screw (1), washer (2) and bracket (3). Carefully peel back wheel liner (4) and place U-nut (5) at location **(A)**.

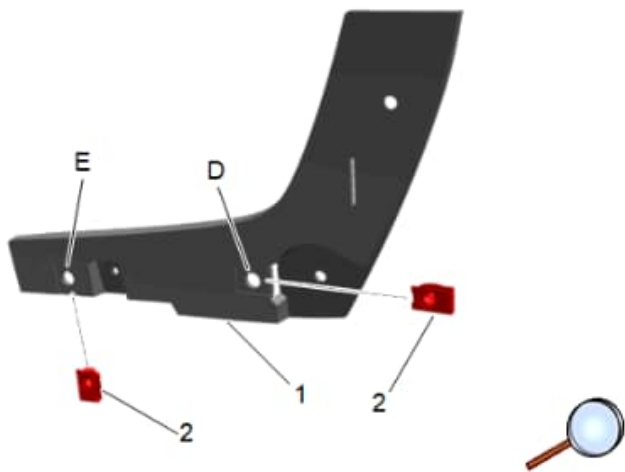

8. Install supplied U-nuts (2) onto the bracket (1) at locations **(D)** and **(E)**.

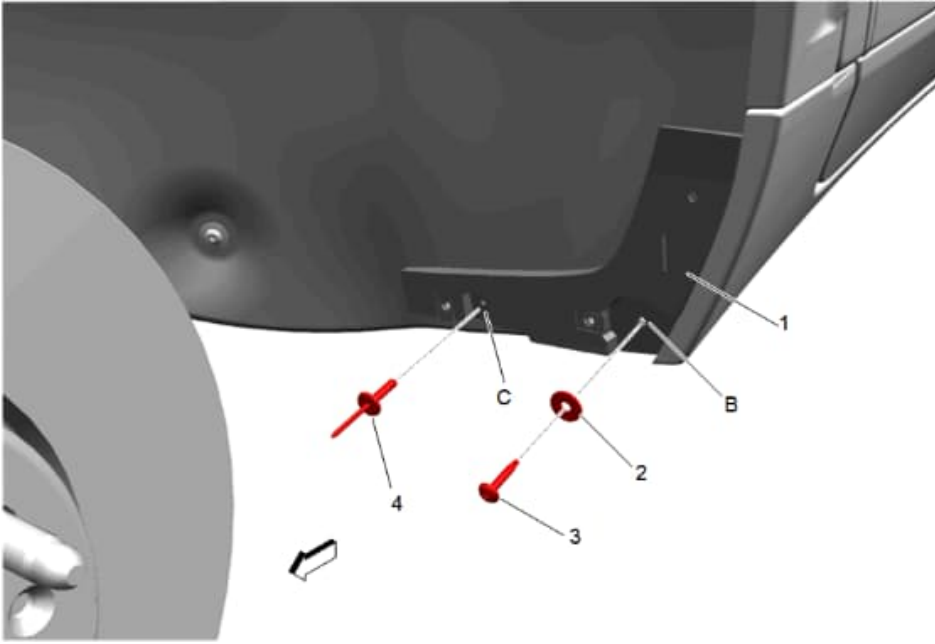

9. Re-Install bracket (1) with short screw (3) and washer (2) at location **(B)**.

**Tighten**

Tighten screw to 3.0 N.m (2.0 lb ft)

10. Install supplied rivet (4) at location **(C)**.

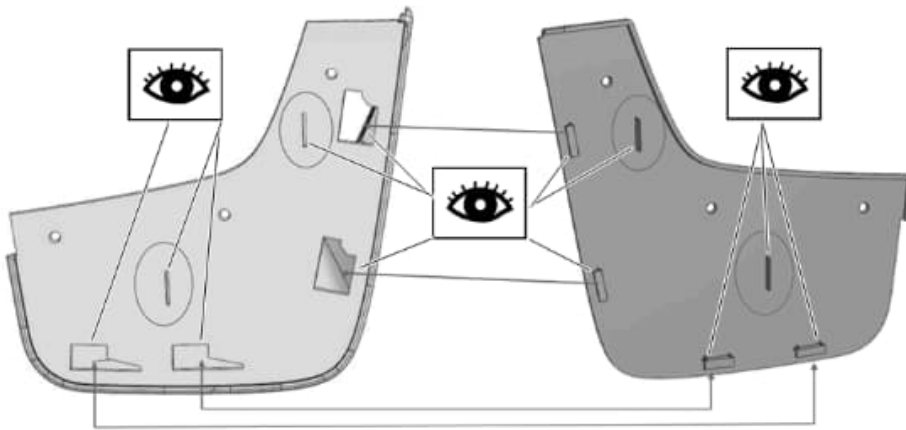

11. Install the splash guard cover to the splash guard, take note of locators and snap both items together.

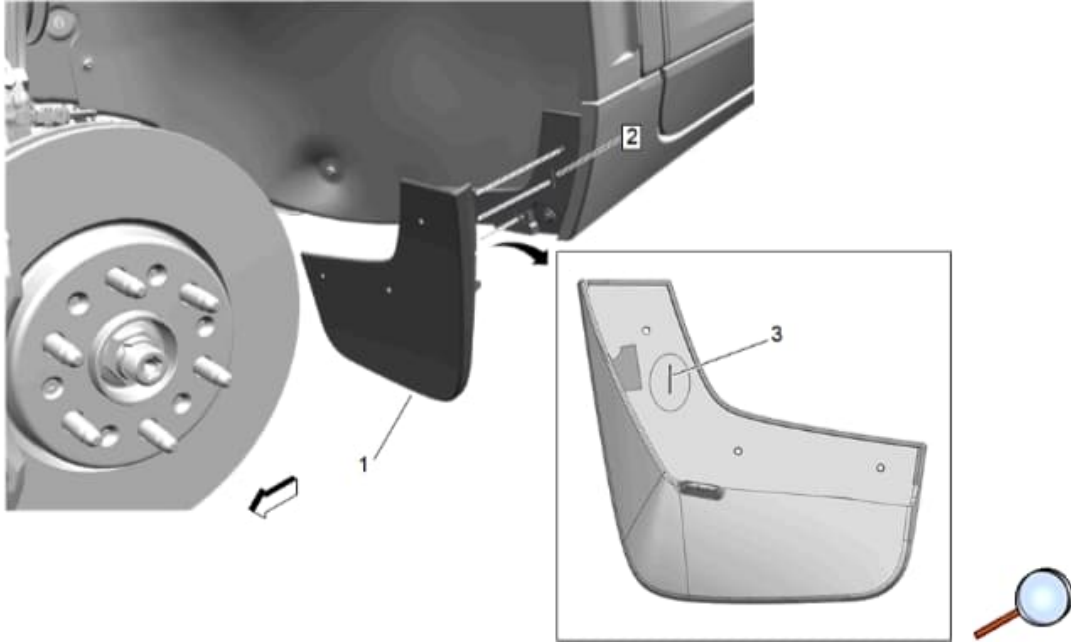

12. Install splash guard (1) to vehicle, make sure locator (3) is placed properly to bracket (2).

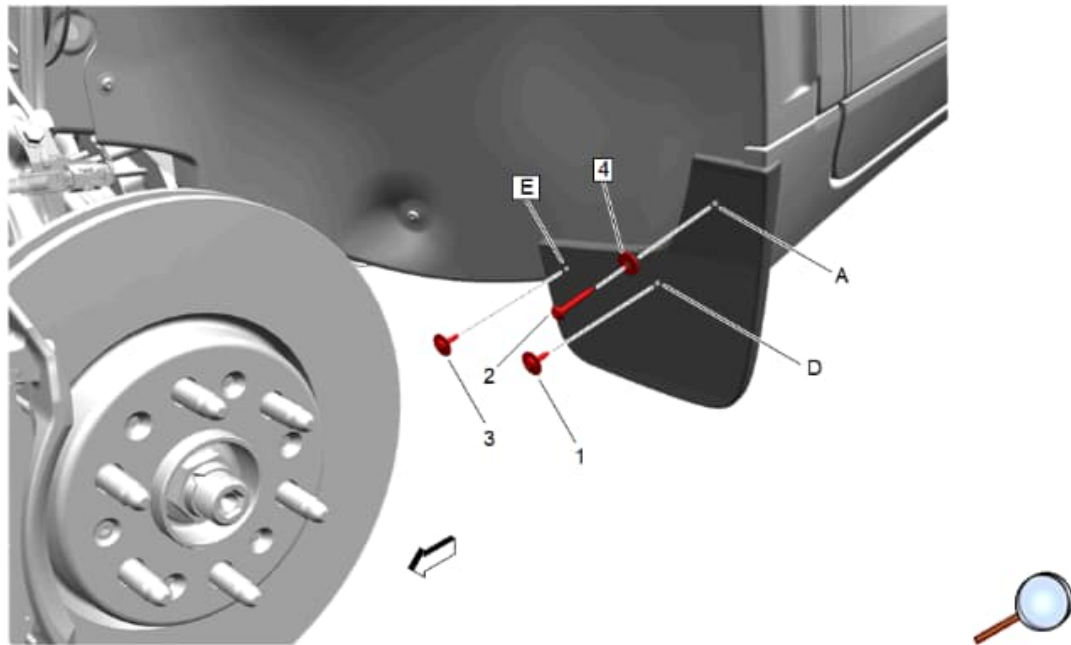

13. Install long screw (2) and washer (4) at location **(A)**, install screw with washer (1) at location **(D)**. Install previously retained screw with washer (3) at location **(E)**.

**Tighten**

Tighten screws to 3.0 N.m (2.0 lb ft).

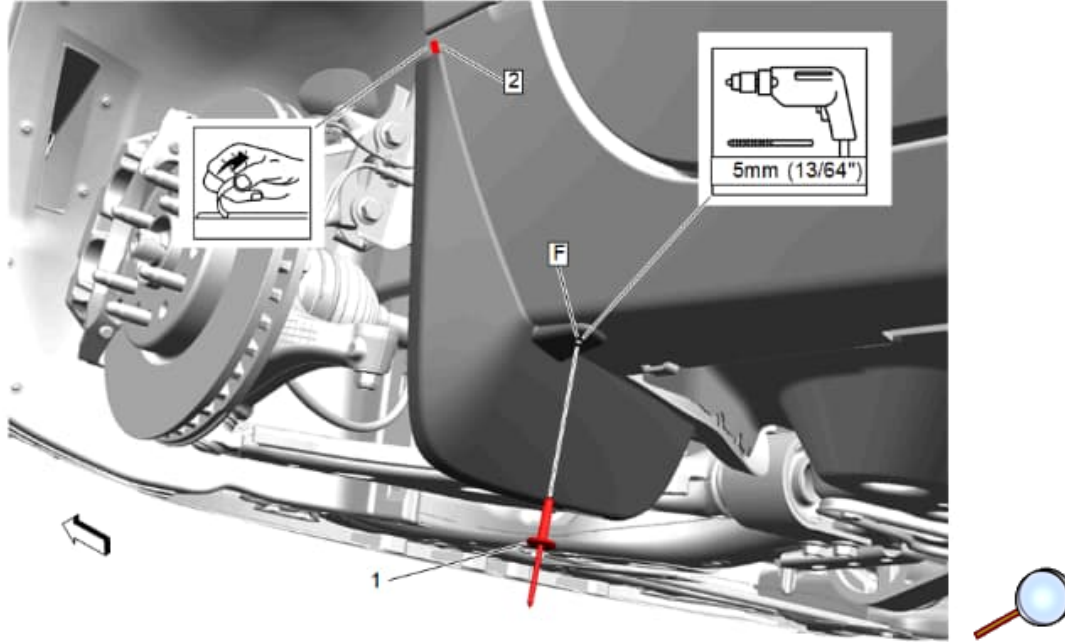

14. While holding the splash guard firmly to the vehicle, carefully drill a 5mm (13/64") hole at location **(F)**.
15. Install supplied rivet (1) at location **(F)**.
16. Remove tape pull tab (2) and apply firm pressure to the splash guard along the tape line to adhere the tape to the fascia. Hold the firm pressure for a minimum of 60 seconds to properly adhere the tape.
17. Install the front wheel and tire assembly. Refer to [Tire and Wheel Removal and Installation](#) in Vehicle Service Manual.
18. Repeat procedure for other side.
19. Guards can be cleaned with any commercially available cleaner.

Please read instructions thoroughly before starting.

#### Kit Contents RPO (VQK)

Qty	Description
1	Left Hand Splash Guard
1	Right Hand Splash Guard
1	Left Hand Bracket
1	Right Hand Bracket
2	Long Screw
2	Short Screw
2	Screw with Washer
4	Washer
4	Rivet
6	U-Nut
1	Instruction Sheet

#### Tools Required

- T15 Torx Screwdriver
- 5mm (13/64") Drill Bit/Drill
- Rivet Gun
- Awl
- Clean Cloth/Rag
- Isopropyl Alcohol

## Procedure RPO (VQK)

1. Remove the front wheel and tire assembly. Refer to [Tire and Wheel Removal and Installation](#) in Vehicle Service Manual.
2. Clean and degrease body panel where splash guards are to be located.
3. Using isopropyl alcohol, clean area where tape will contact body panel.

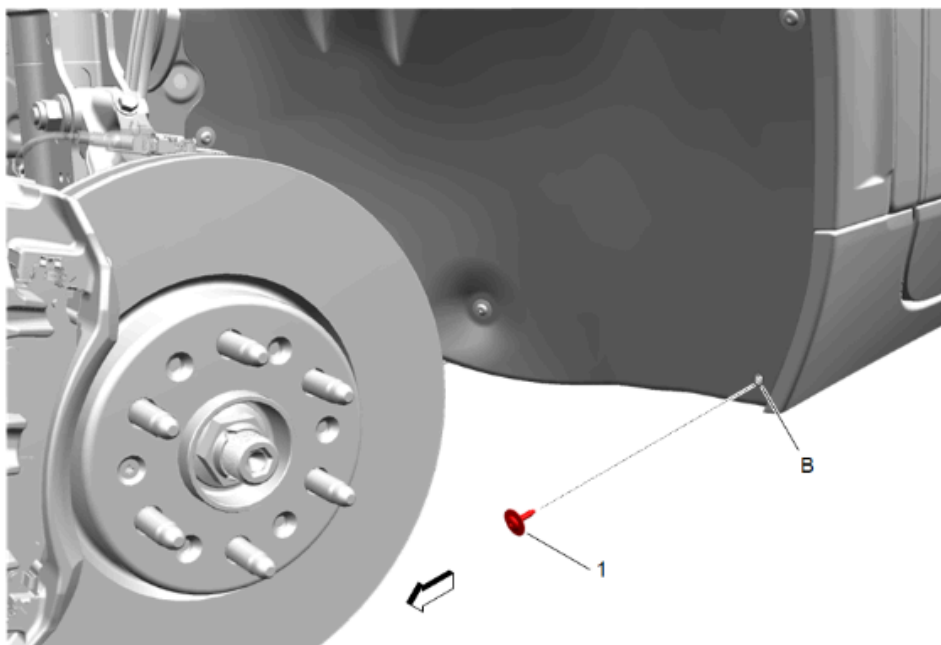

4. Remove existing screw (1) at location (B) and retain screw.

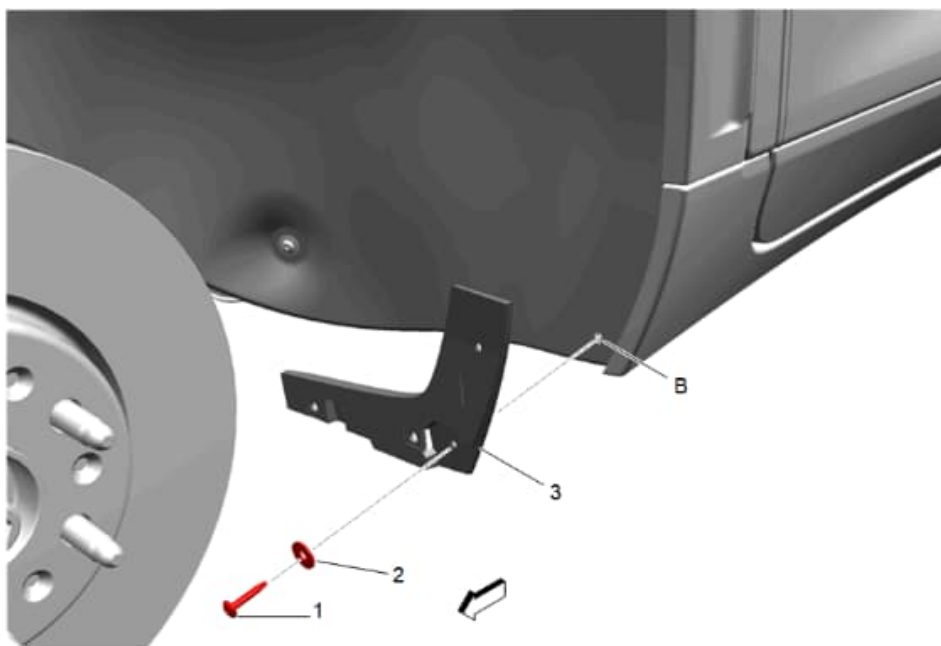

**Caution:** Use the correct fastener in the correct location. Replacement fasteners must be the correct part number for that application. Fasteners requiring replacement or fasteners requiring the use of thread locking compound or sealant are identified in the service procedure. Do not use paints, lubricants, or corrosion inhibitors on fasteners or fastener joint surfaces unless specified. These coatings affect fastener torque and joint clamping force and may damage the fastener. Use the correct tightening sequence and specifications when installing fasteners in order to avoid damage to parts and systems.

5. Install bracket (3) to the vehicle with short screw (1) and washer (2) at location (B).

### **Tighten**

Tighten screw to 3.0 N.m (2.0 lb ft)

**Caution:** Always check size and position of all holes before drilling. Failing to do so may cause damage to the vehicle, misalignment of components or the inability to install the accessory.

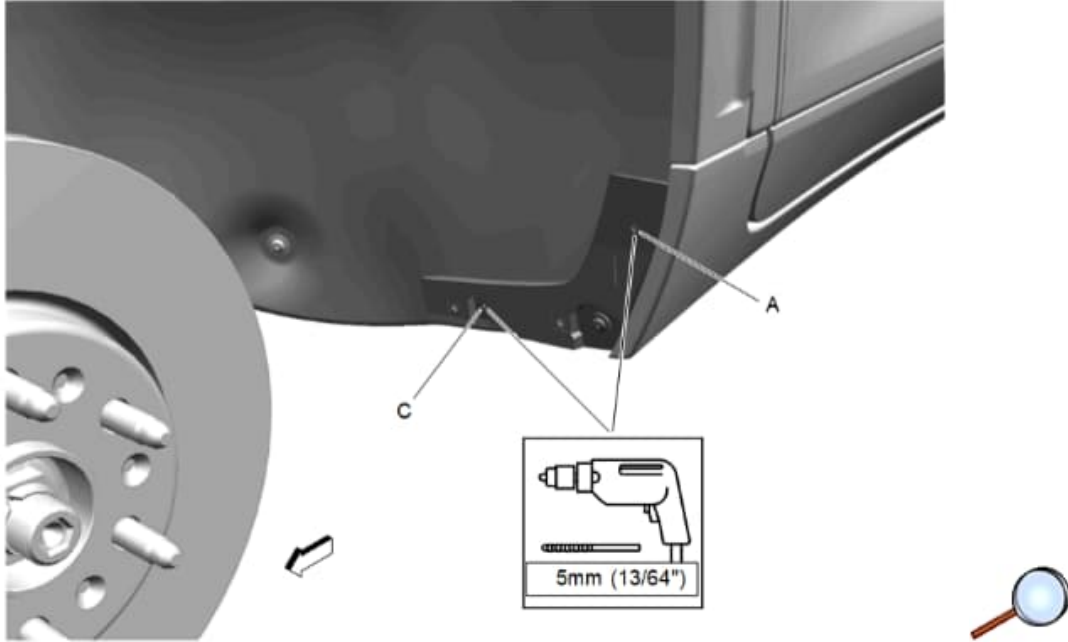

6. While holding the bracket firmly to the vehicle, carefully drill a 5mm (13/64") hole at location **(A)** and **(C)**.

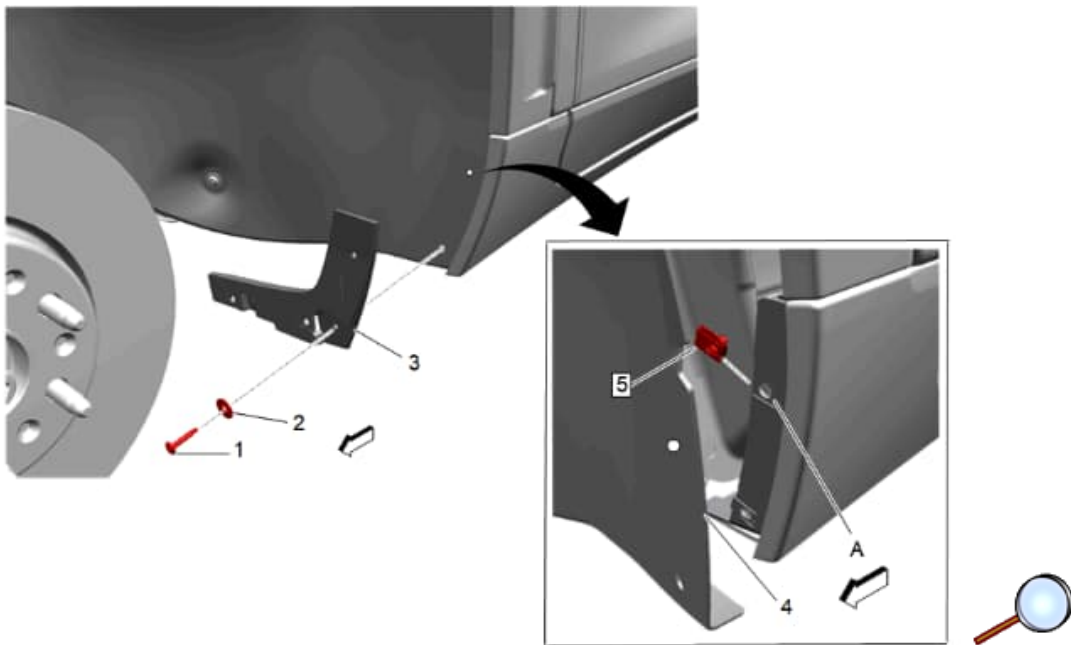

7. Remove the screw (1), washer (2) and bracket (3). Carefully peel back wheel liner (4) and place U-nut (5) at location **(A)**.

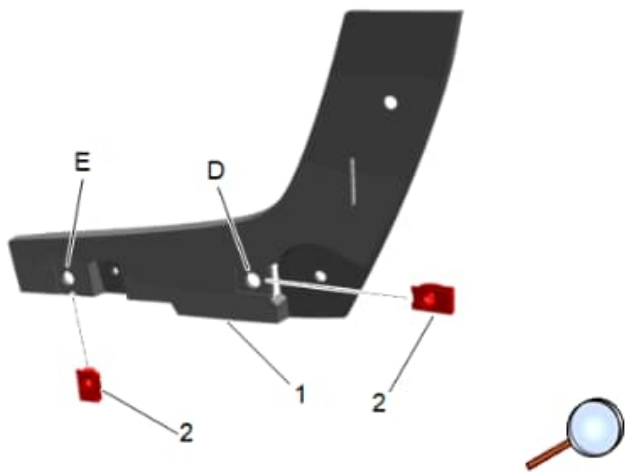

8. Install supplied U-nuts (2) onto the bracket (1) at locations **(D)** and **(E)**.

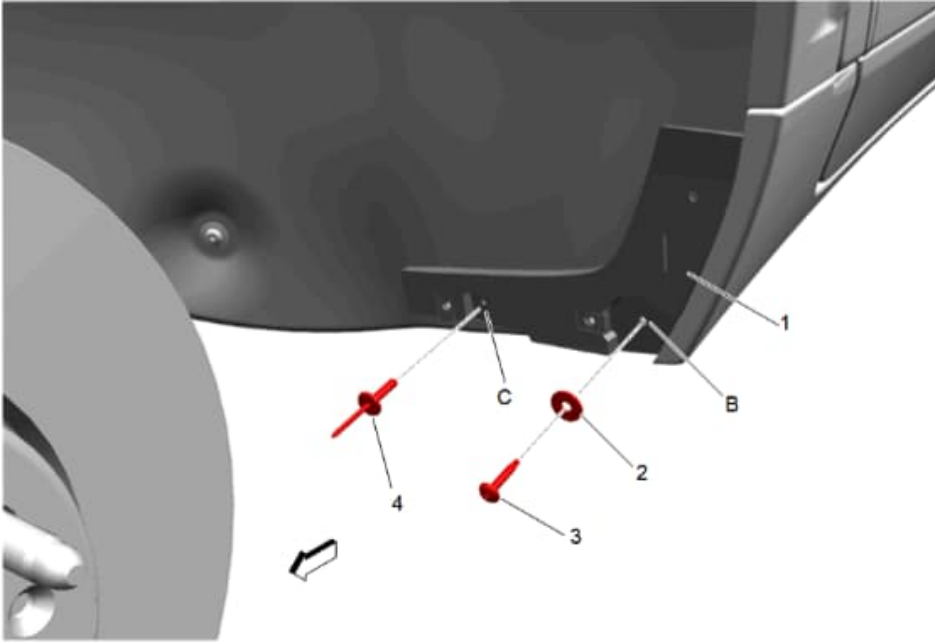

9. Re-Install bracket (1) with short screw (3) and washer (2) at location **(B)**.

**Tighten**

Tighten screw to 3.0 N.m (2.0 lb ft)

10. Install supplied rivet (4) at location **(C)**.

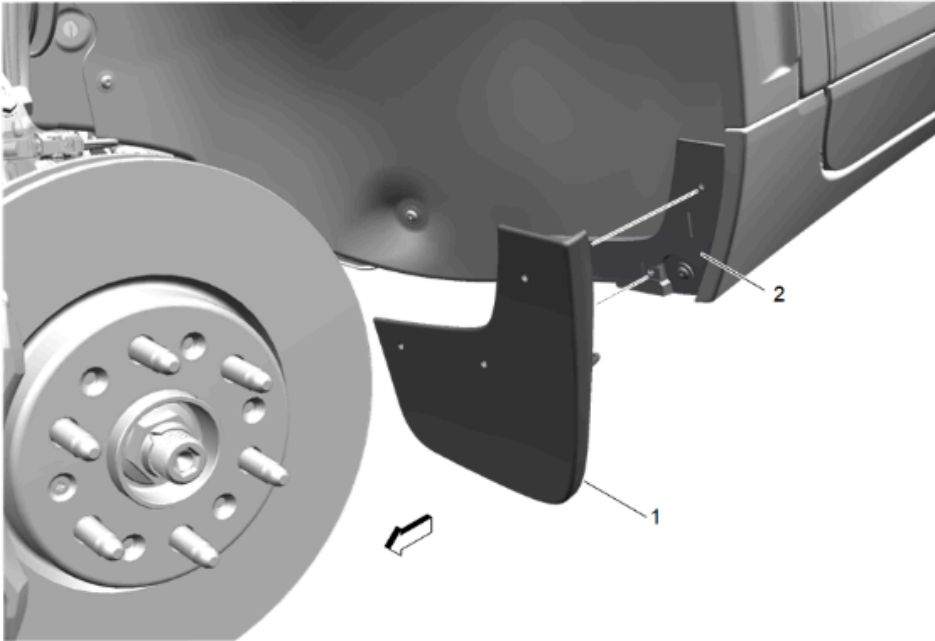

11. Install splash guard (1) to vehicle, make sure locator (3) is placed properly to bracket (2).

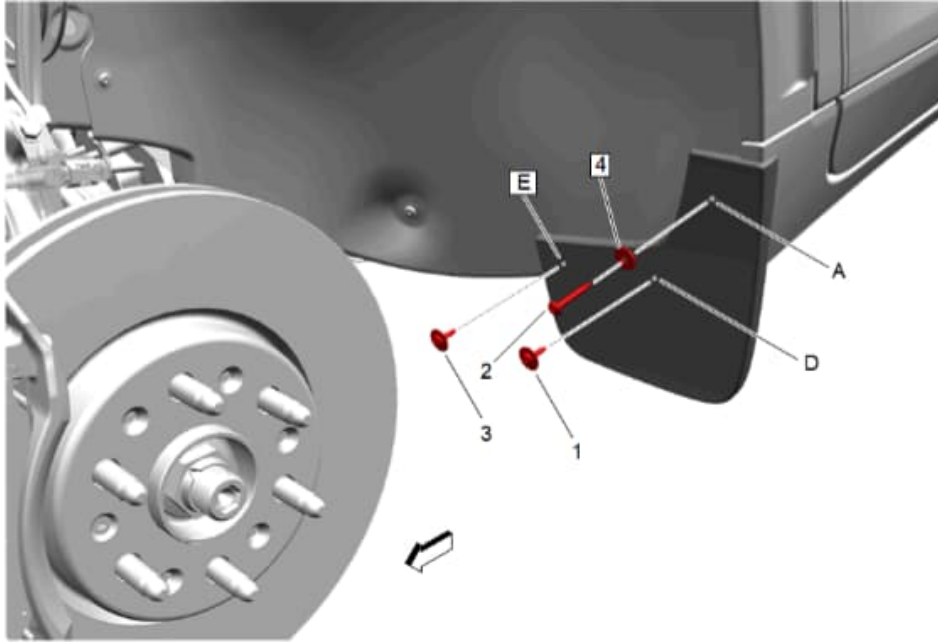

12. Install long screw (2) and washer (4) at location **(A)**, install screw with washer (1) at location **(D)**. Install previously retained screw with washer (3) at location **(E)**.

**Tighten**

Tighten screws to 3.0 N.m (2.0 lb ft).

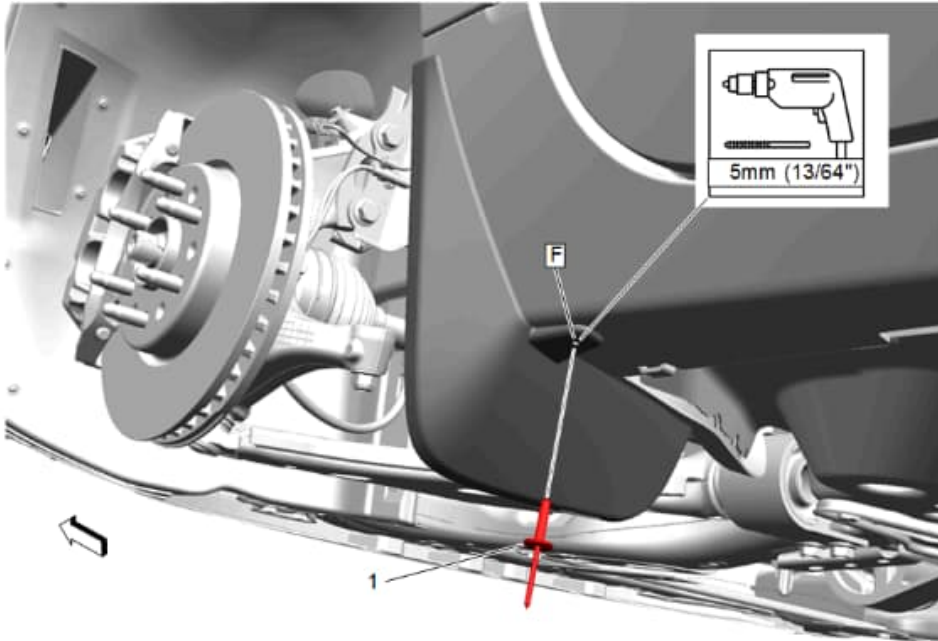

13. While holding the splash guard firmly to the vehicle, carefully drill a 5mm (13/64") hole at location **(F)**.

14. Install supplied rivet (1) at location **(F)**.

15. Install the front wheel and tire assembly. Refer to [Tire and Wheel Removal and Installation](#) in Vehicle Service Manual.

16. Repeat procedure for other side.

17. Guards can be cleaned with any commercially available cleaner.