

Side Decal Package Installation Installation

Instructions Part Number

85542112

Side Decal Package Installation

DESCRIPTION	QUANTITY
Decal - Bodyside Lower RH	1
Decal - Bodyside Lower LH	1
Installation Instructions	1

Tools Required

- 70% Isopropyl Alcohol
- Lint-free Towels
- Sewing Needle (Never use a razor blade)
- Plastic Squeegee: Lidco Products Industry Standard 4-inch Squeegee RC-4-W #1007
- Trigger-type Spray Bottles
- Unscented Liquid Dish Soap

Procedure

Preparation - Before Installation

1. After opening the kit, check to see if any parts are missing and that the product is not damaged.
2. This product should be installed with proper installation tools.
3. Install this product while observing all warnings and precautions stated in this instruction booklet.
4. **IMPORTANT: Begin with a thoroughly washed vehicle.**
5. Ambient temperature of decals and vehicle must be 70°F / 21°C to 90°F / 32°C at the time of installation and for a minimum of 30 minutes and up to two hours after.
6. Thoroughly clean vehicle surface with 70% isopropyl alcohol and follow with a dry wipe.
7. To ensure bubble-free application, put three or four tiny drops of liquid detergent into a 24 oz. / 750 ml trigger-type spray bottle and fill with water. Replace the top and shake to mix the soap and water "surfactant." Set nozzle for a fine mist.

Installation Notes

1. All of the decals include premask carrier extensions and notches that allow the installer to accurately align the decal to the body panel.
2. The soap / water "surfactant" is intended to allow the installer the opportunity to position the stripe before any pre-adhesion can occur. If the decal sticks prematurely and does not easily "glide" across the surface of a body panel, increase the amount of surfactant that has been applied to the body panel and/or place additional soap into the spray bottle and re-spray.
3. The adhesive is activated by pressure. Be sure to use firm, overlapping strokes, beginning at the center of the decal and working toward the edges of the decal.
4. When using the squeegee, be careful not to drag the squeegee onto the painted body panel.
5. After premask removal, never use an uncovered squeegee to re-press a decal into place. Wrap the squeegee with a towel or re-spray the surface with surfactant.
6. The bodyside decals have a paper-premask carrier. Should this carrier be difficult to remove, spray the carrier paper with the surfactant and wait 10 seconds for the carrier to soften and release from the decal.
7. If bubbles are present after premask carrier removal, wrap a towel around the squeegee and carefully attempt to push bubble to the side of the decal. If the bubble cannot be moved, use a sewing needle to pierce the bubble and press the remaining solution from beneath the decal.

Note: After a decal installation has been completed, do not high pressure wash the vehicle for 72 hours.

Bodyside Decal LH or RH

1. Prepare surface as described in preparation section.
2. Use the surfactant to saturate the area where the decal is to be applied.

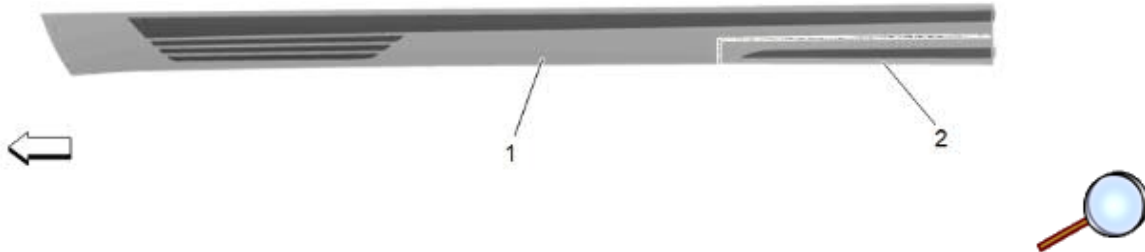

Note: Left side shown, right side similar.

3. Separate the rear door portion (2) from the front door portion (1) along the perforation.

Note: The rear door portion needs to be rotated for proper orientation.

4. Lay the decal upside down on a flat surface and slowly remove the liner from the decal without bending the decal. The adhesive side of the decal will now be exposed.
5. Saturate the adhesive side of the decal.
6. Carefully lift the decal from the surface and lay the adhesive side onto the panel.

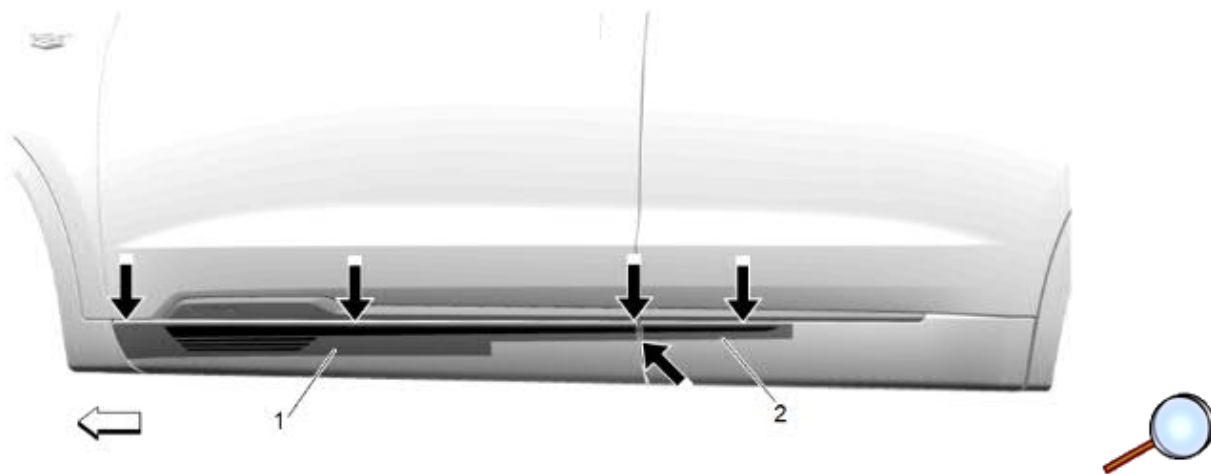

Note: Left side shown, right side similar.

7. Align the rear edge of the premask carrier of the front door portion to the rear edge of the front door while aligning the top edge of the carrier to the feature line. (1).
8. Align the front edge of the premask carrier of the rear door portion to the front edge of the rear door while aligning the actual decal to the installed front door decal. (2)
9. Use the plastic squeegee to press the decal into place. Beginning at the center of the decal and working towards the sides using firm overlapping strokes. If necessary, slightly lift the decal when approaching the ends (to minimize wrinkling).
10. Spray surfactant onto the premask to ease in removal.

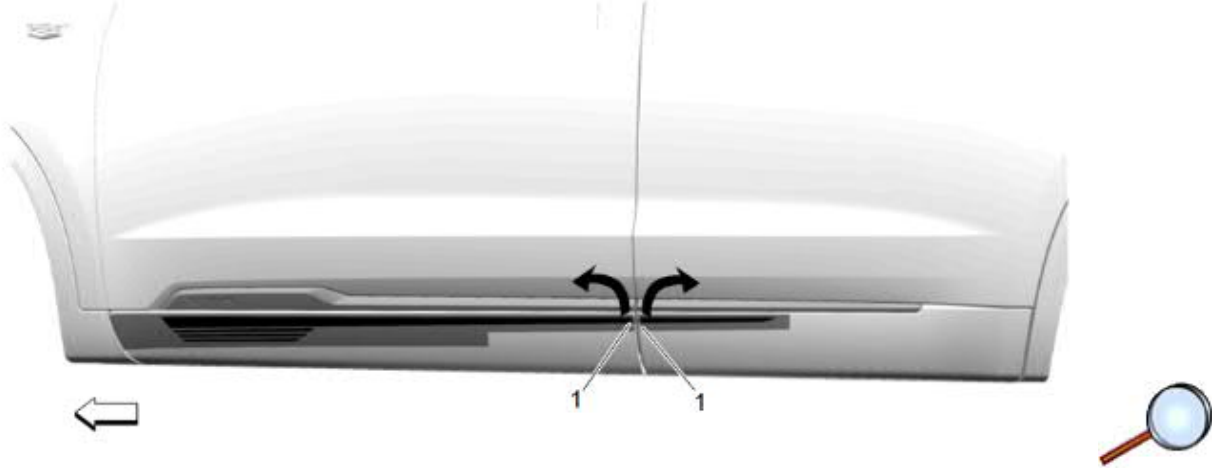

Note: Left side shown, right side similar.

11. Slowly remove the top premask carrier (1) by pulling it off at 180 degrees, being careful not to tear the decal.

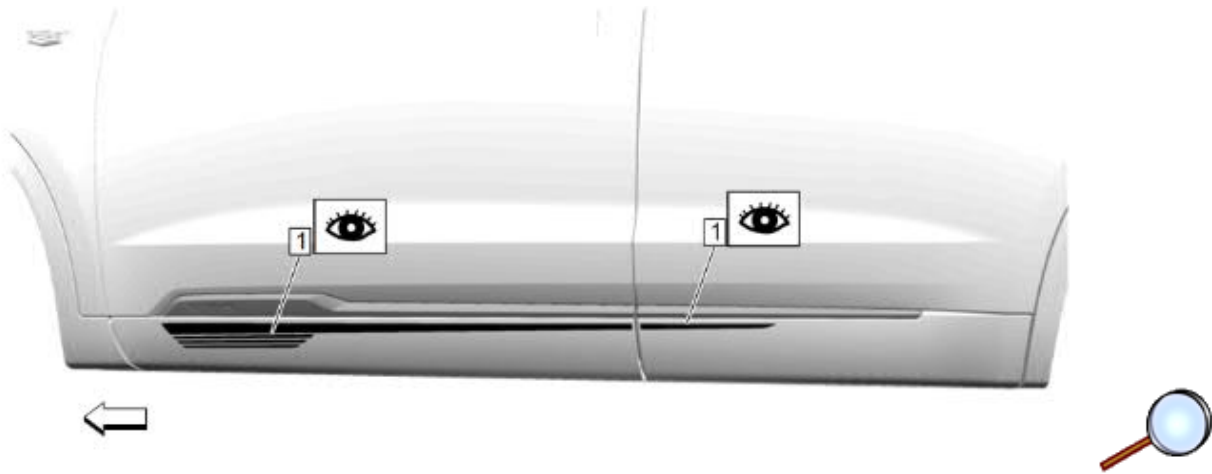

Note: Left side shown, right side similar.

12. Clean off the residual surfactant with a lint-free cloth and inspect the decal. (1)