

Front Fender Mud Guard Package Installation

Installation Instructions Part Number

85587496

Please read instructions thoroughly before starting.

Kit Contents

| Qty | Description |
|-----|-------------------------|
| 1 | Left Hand Splash Guard |
| 1 | Right Hand Splash Guard |
| 2 | Rivet |
| 4 | Plastic W-Clip |
| 1 | Instruction Sheet |

Special Tools

- T15 Torx Screwdriver
- 5mm (13/64") Drill Bit
- Drill
- Rivet Gun
- Clean Cloth/Rag

Procedure

Note: Front wheel/tire assembly shown removed for clarity.

1. Turn front wheel to provide adequate clearance.
2. Clean and degrease body panel where splash guards are to be located.

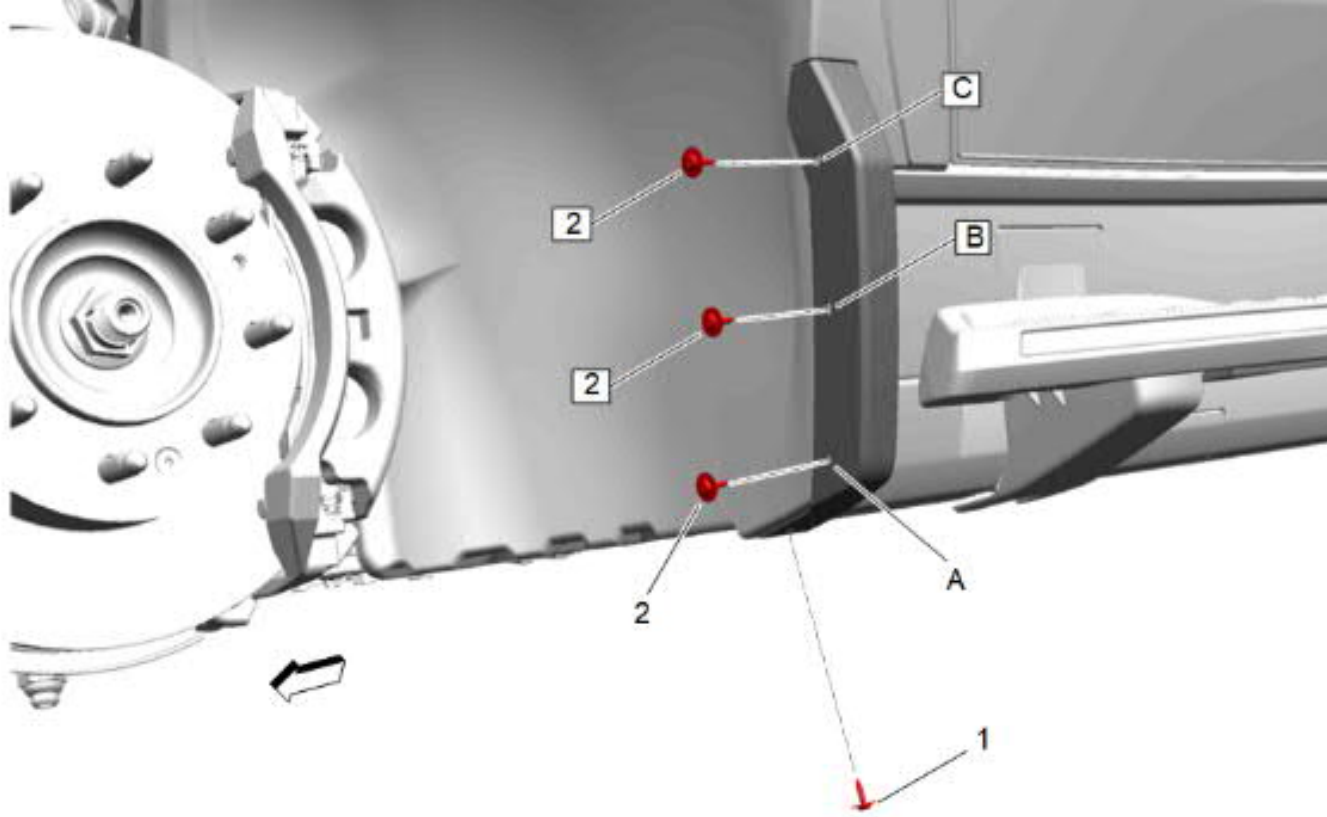

3. Remove and discard existing lower screw (1).
4. Remove and retain existing screws (2) at locations **A**, **B** and **C**.

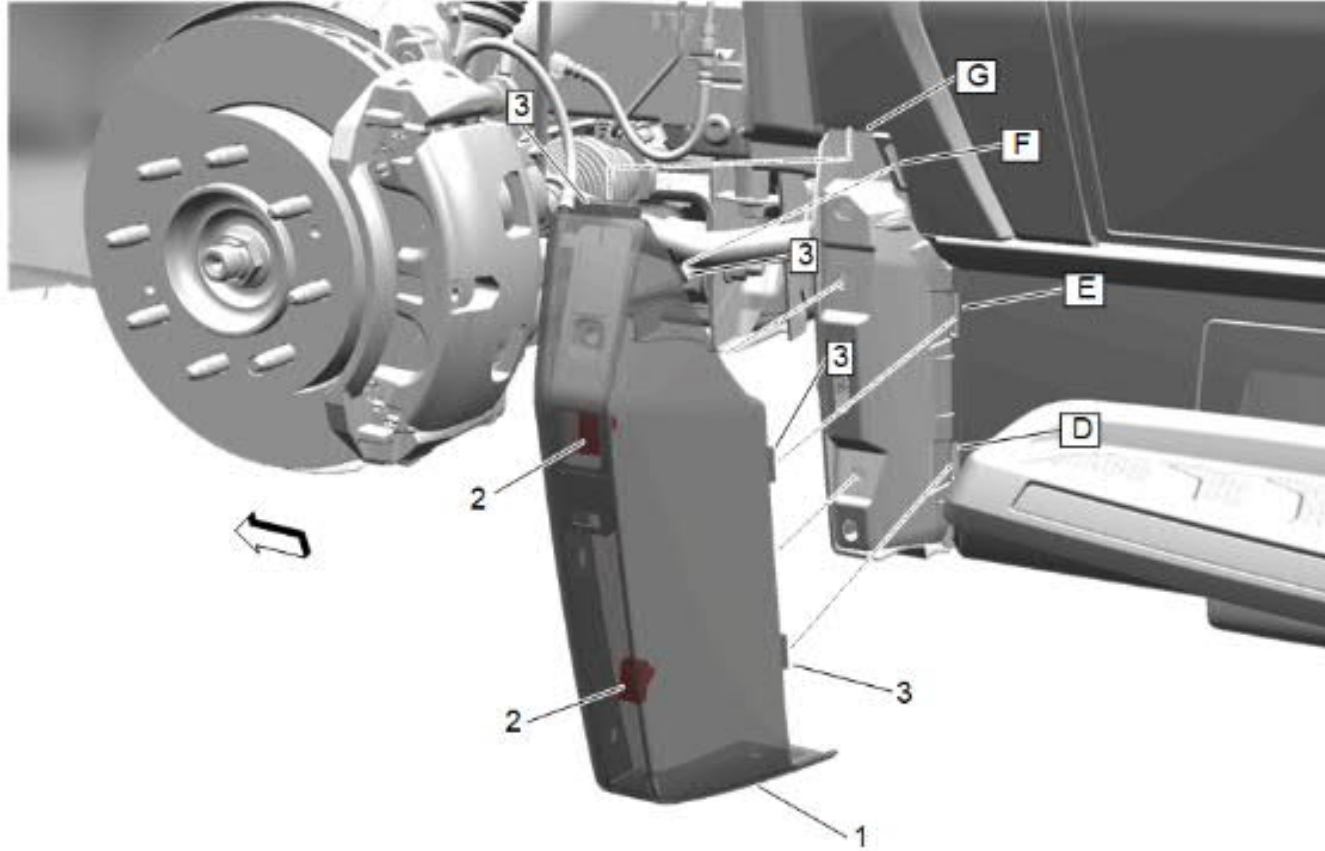

5. Remove the existing splash guard (1) by disengaging the retainers (2), and snaps (3) at locations **D**, **E**, **F** and **G**.

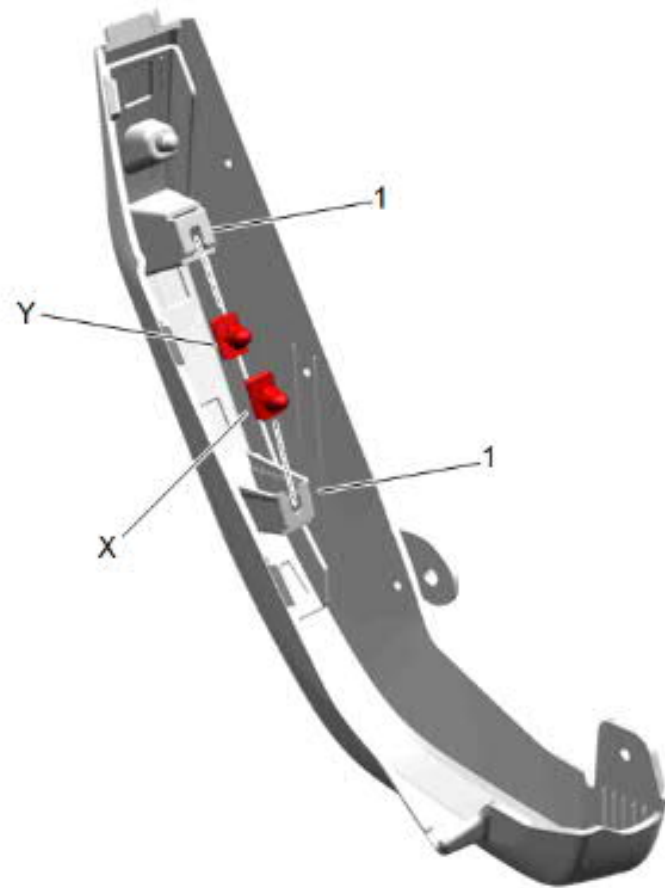

6. Insert the W-clips (X), (Y) into the slots of the mud guard (1).

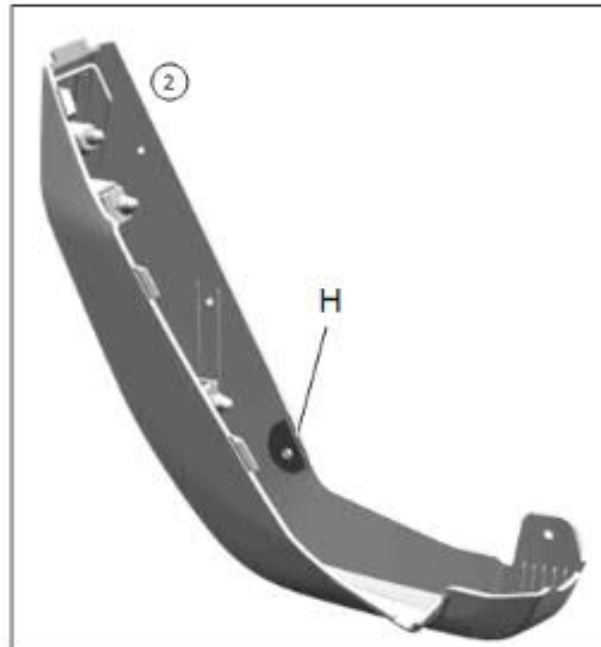
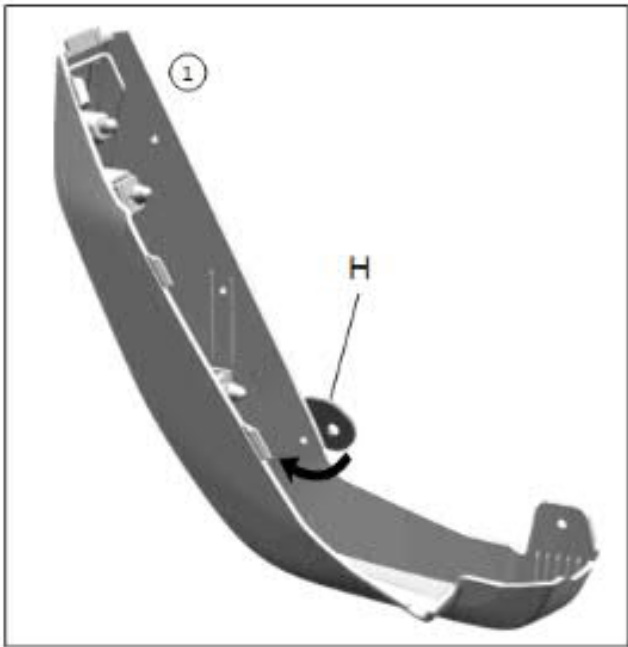

7. Fold the living hinge (H) on new splash guard to the closed position.

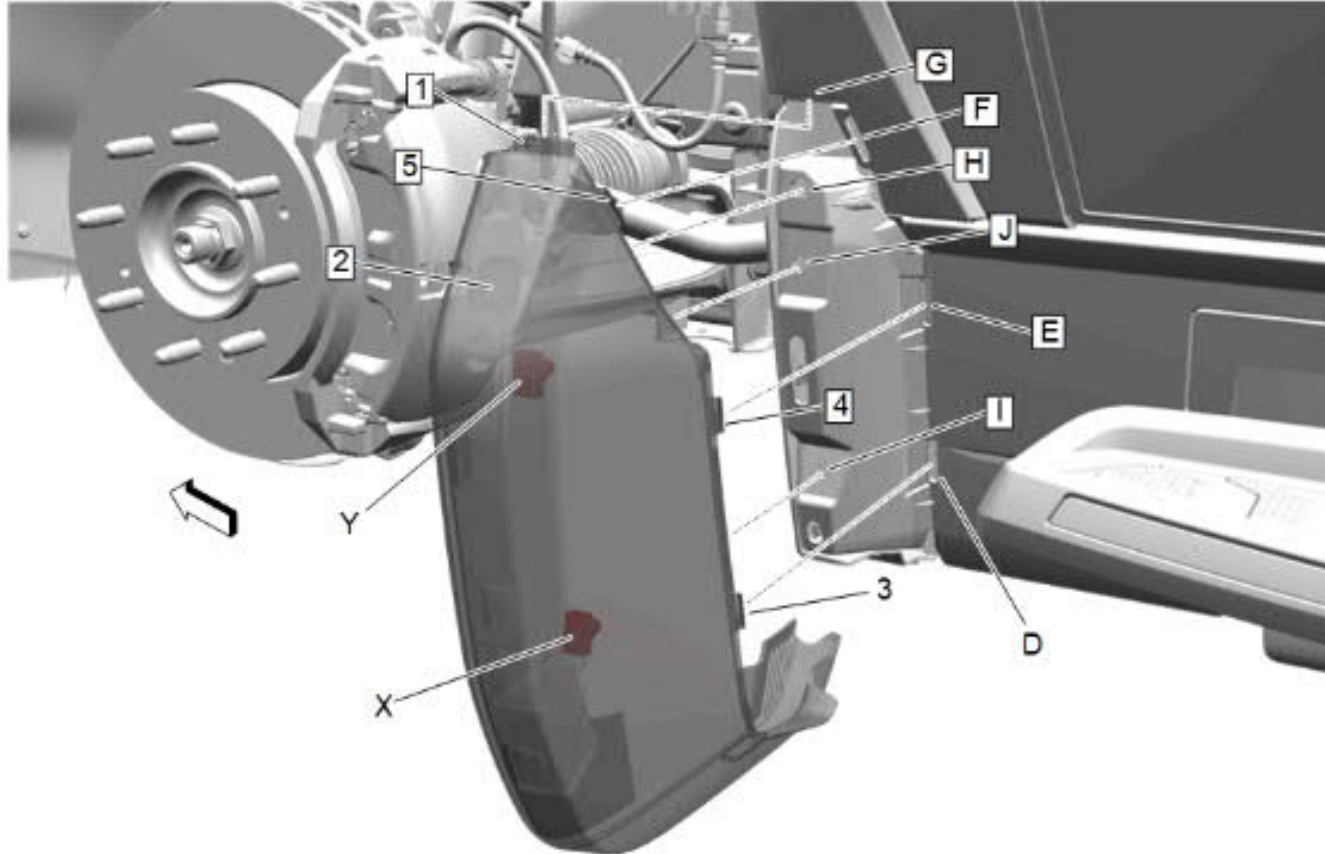

8. Place the splash guard to the vehicle engaging the W-clips (X), (Y) are inserted into holes (I) and (J) while positioning top tab (1) into slot (G) and inserting the locator pin (2) into location (H). After getting these located/inserted, rotate bottom of splash guard fully in to engage snaps (3), (4) and (5) into locations (D), (E) and (F).

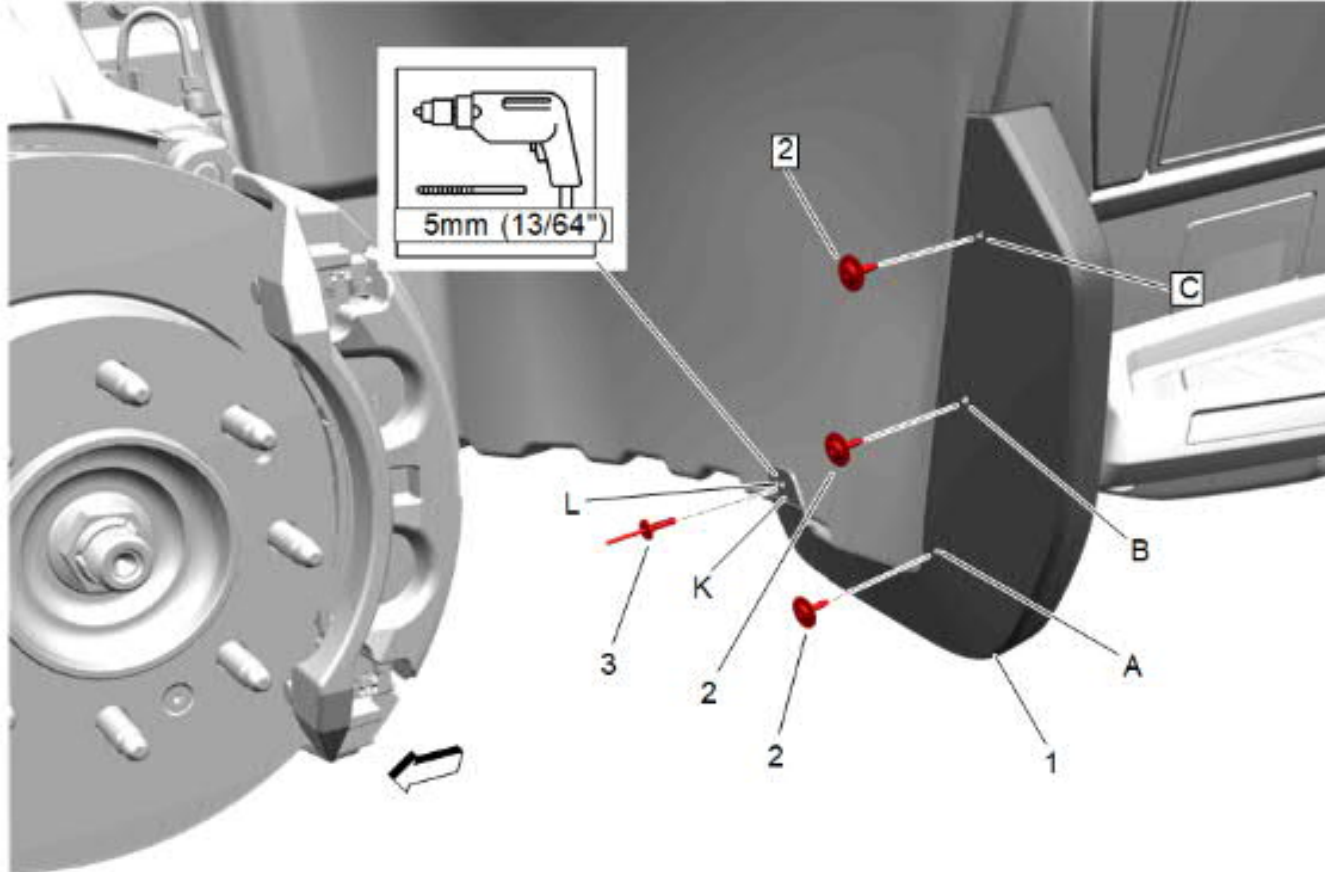

Caution: Use the correct fastener in the correct location. Replacement fasteners must be the correct part number for that application. Fasteners requiring replacement or fasteners requiring the use of thread locking compound or sealant are identified in the service procedure. Do not use paints, lubricants, or corrosion inhibitors on fasteners or fastener joint surfaces unless specified. These coatings affect fastener torque and joint clamping force and may damage the fastener. Use the correct tightening sequence and specifications when installing fasteners in order to avoid damage to parts and systems.

9. Install previously retained screws (2) to splash guard (1) at locations **(A)**, **(B)** and **(C)**.

Tighten

Tighten screws to 3.0 N.m (2.0 lb ft)

Caution: Always check size and position of all holes before drilling. Failing to do so may cause damage to the vehicle, misalignment of components or the inability to install the accessory.

10. While holding the splash guard (1) tight to vehicle to remove any gaps, bend the living hinge (K) upward; use the hole at location **(L)** and carefully drill a 5mm (13/64") hole through splash guard and wheel liner and install supplied rivet (3) at this location.
11. Repeat procedure for opposite side.
12. Guards can be cleaned with any commercially available cleaner.

