

Rear Mud Guard Package Installation

Installation Instructions Part Number

85587501

Please read instructions thoroughly before starting.

Kit Contents

Qty	Description
1	Left Hand Splash Guard
1	Right Hand Splash Guard
2	Rivet
4	W-Clips
1	Instruction Sheet

Special Tools

- T15 Torx Screwdriver
- 5mm (13/64") Drill Bit/Drill
- Rivet Gun
- Plastic Flat Bladed Tool
- Clean Cloth/Rag

Procedure

1. Remove the rear wheel and tire assembly. Refer to [Tire and Wheel Removal and Installation](#) in Vehicle Service Manual.

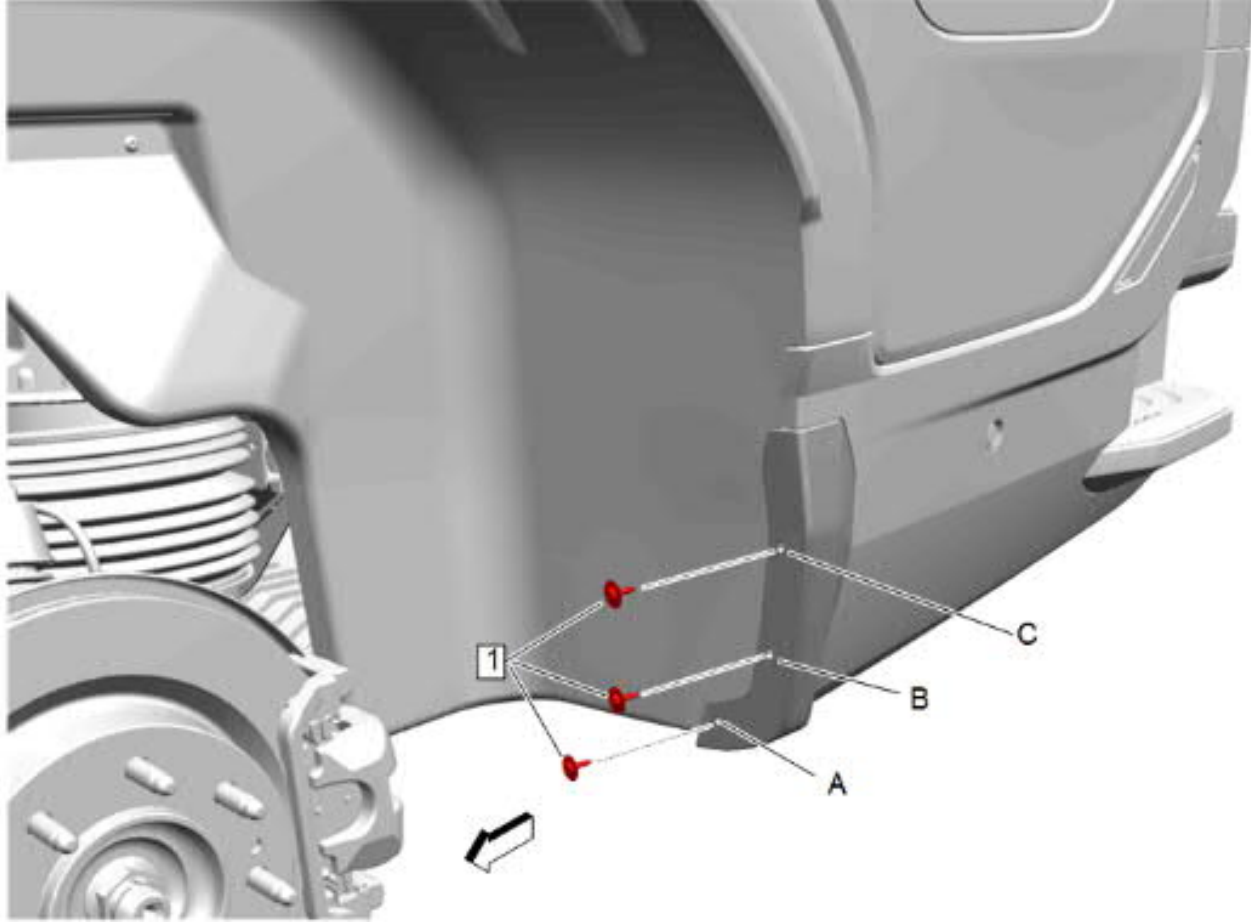

2. Remove and retain the three screws (1) from locations (A), (B) and (C) from stone guard.

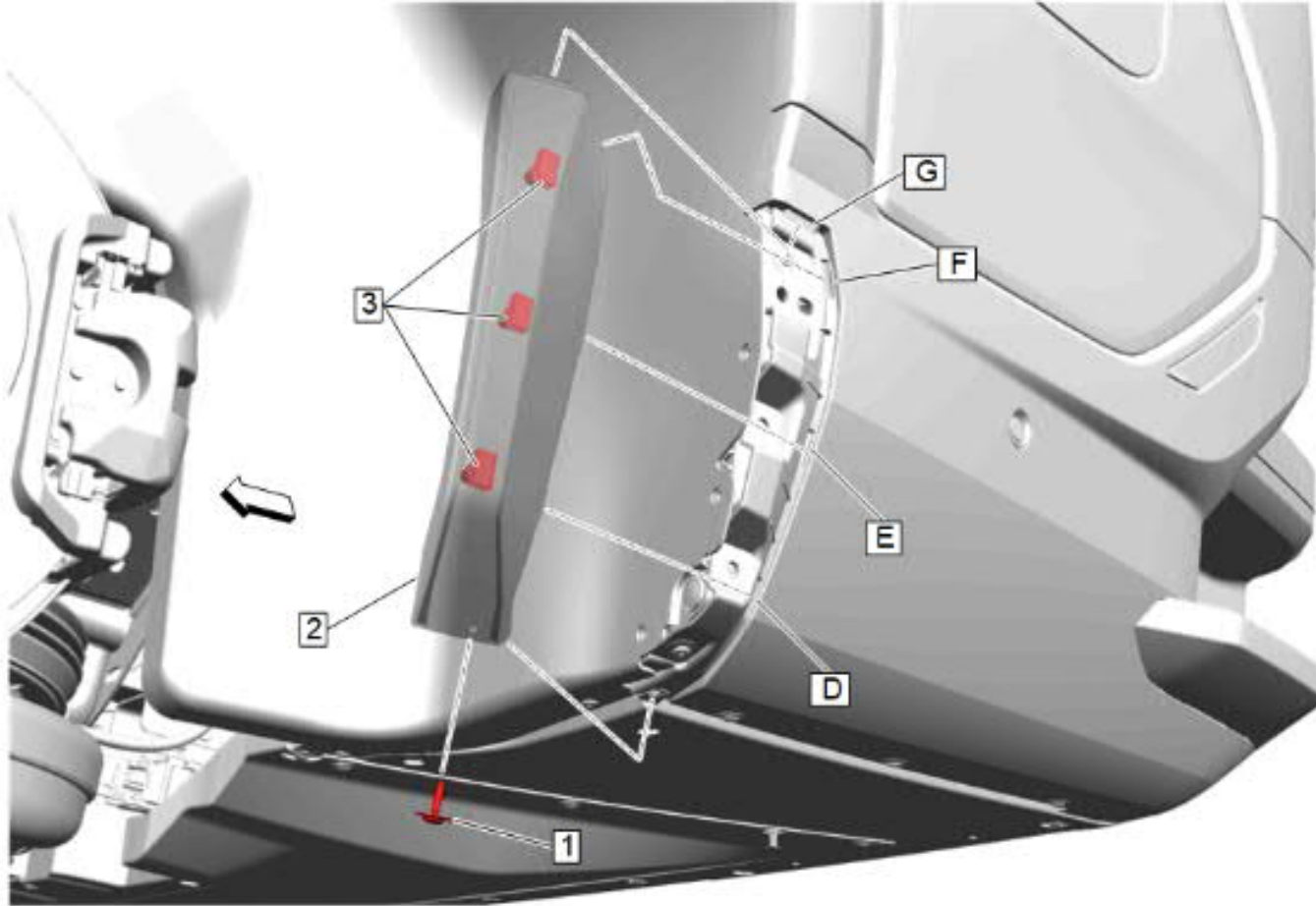

3. Remove and discard lower screw (1) from stone guard (2).
4. Using a suitable plastic flat-bladed tool, disengage the retainers and then disengage the snaps from locations (D), (E), (F) and (G). Remove stone guard (2) from vehicle.
5. Clean and degrease body panel where splash guards are to be located.

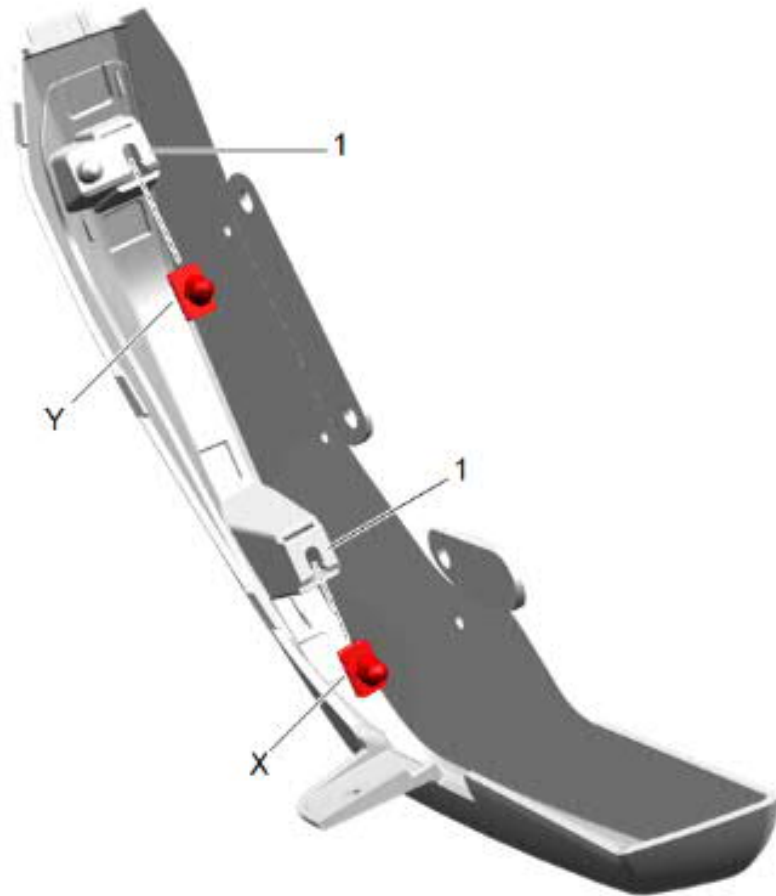

6. Insert the W-clips (X), (Y) into the slots of the mud guard (1).

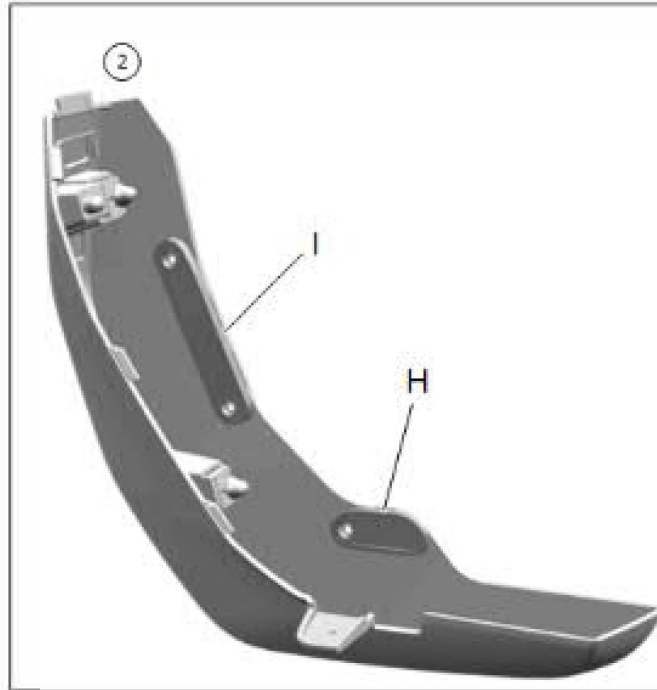
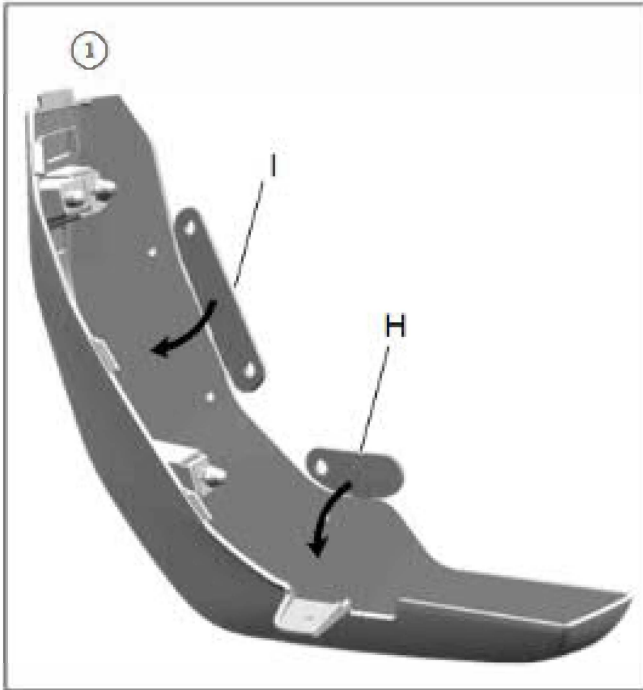

7. Make sure foldable hinges (H) and (I) are fully folded into place.

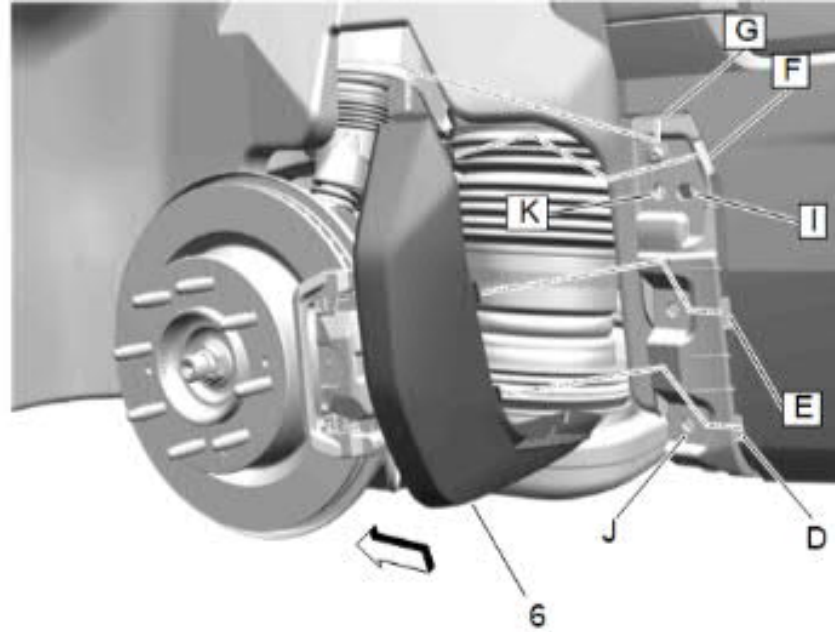
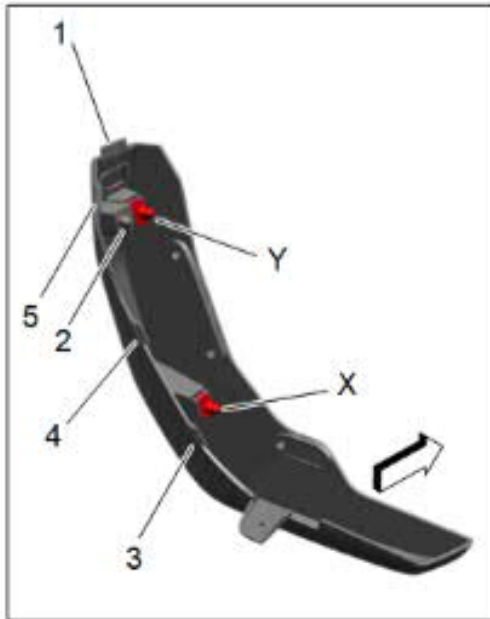

8. Place splash guard (6) to vehicle ensuring that the retainers (X) and (Y) are inserted into holes (J) and (K) while inserting the top tab (1) into slot (G) and then inserting the locator pin (2) into location (I). After getting these located/inserted, rotate bottom of splash guard inward and push splash guard fully in to engage snaps (3), (4) and (5) into locations (D), (E) and (F).

Note: You may need help to locate the bottom retainer (X) with finger or implement when rotating bottom guard inward.

Caution: Use the correct fastener in the correct location. Replacement fasteners must be the correct part number for that application. Fasteners requiring replacement or fasteners requiring the use of thread locking compound or sealant are identified in the service procedure. Do not use paints, lubricants, or corrosion inhibitors on fasteners or fastener joint surfaces unless specified. These coatings affect fastener torque and joint clamping force and may damage the fastener. Use the correct tightening sequence and specifications when installing fasteners in order to avoid damage to parts and systems.

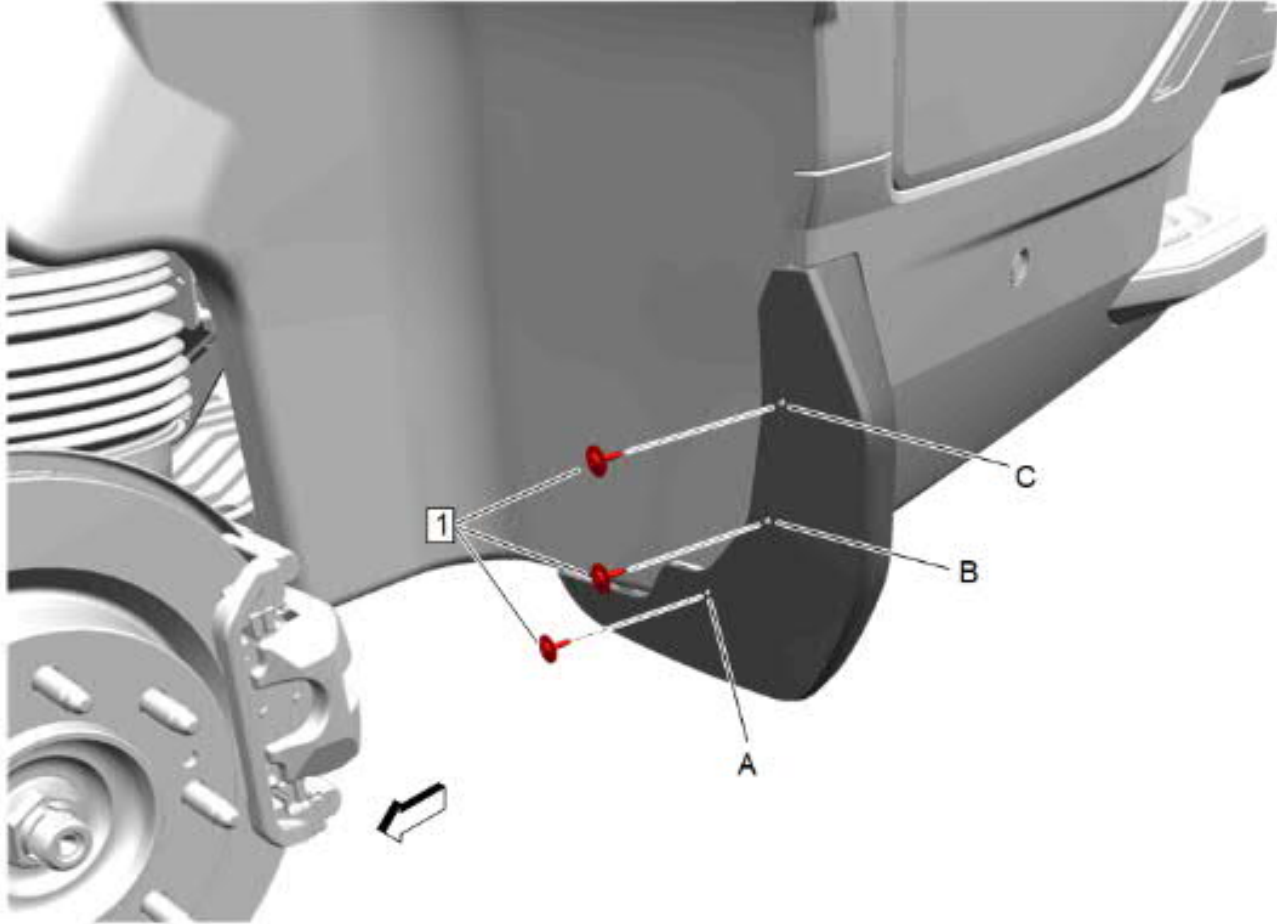

9. Install the previously retained screws (1) to locations (A), (B) and (C).

Tighten

Tighten screws to 3.0 N.m (2.0 lb ft)

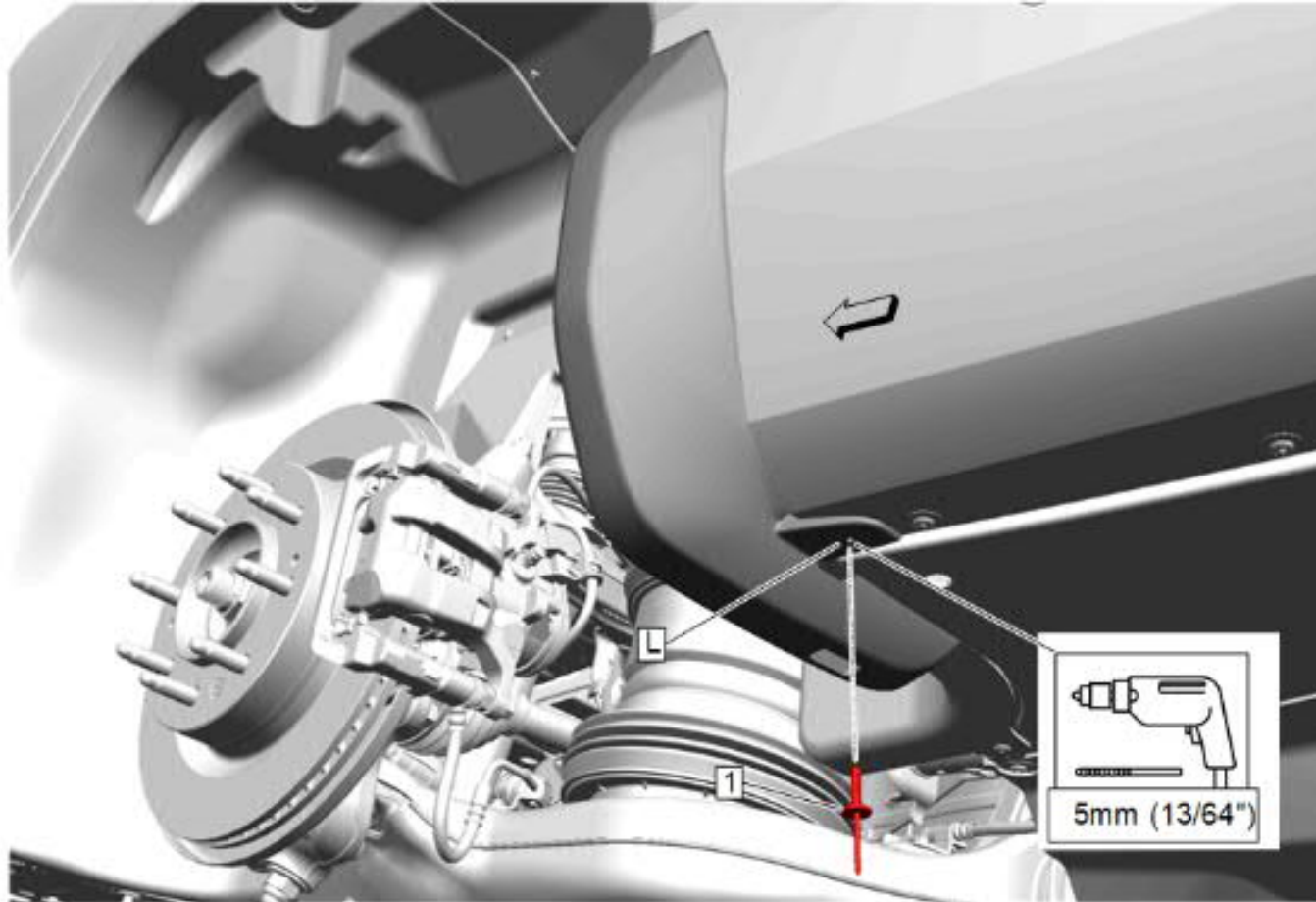

Caution: Always check size and position of all holes before drilling. Failing to do so may cause damage to the vehicle, misalignment of components or the inability to install the accessory.

10. While holding the splash guard firmly to the vehicle to remove any gaps, using the hole at location (L) as a guide, carefully drill a 5mm (13/64") hole through the splash guard and vehicle panel.
11. Install supplied rivet (1) at location (L).
12. Install the rear wheel and tire assembly. Refer to [Tire and Wheel Removal and Installation](#) in Vehicle Service Manual.
13. Repeat procedure for other side.
14. Guards can be cleaned with any commercially available cleaner.