

# Pickup Box Ornamentation Bar Package Installation

**Table 1:** [Kit Contents](#)

**Table 2:** [Special Wiring Instructions](#)

**Table 3:** [Recommended Tools](#)

## Installation Instructions Part Number

85625080

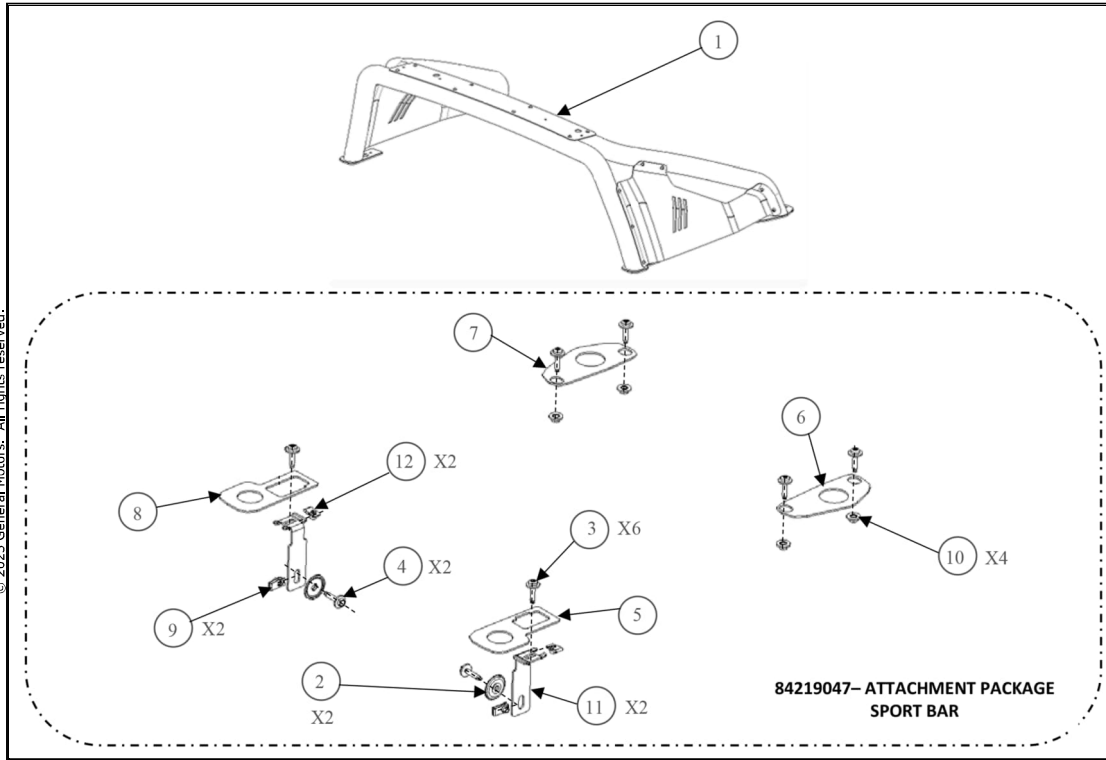

## Kit Contents

Item	Qty	Description
1	1	Sport Bar Assembly
2	2	Round Nylon Washer
3	6	M8 - 1.25 X 39.05mm Screw T40 W/CONICAL WASHER
4	2	M8 - 1.25 X 40mm Hex Bolt W/CONICAL WASHER
5	1	DS Front Die Cut Foam Single Side PSA
6	1	DS Rear Die Cut Foam Single Side PSA
7	1	PS Front Die Cut Foam Single Side PSA
8	1	PS Rear Die Cut Foam Single Side PSA

Item	Qty	Description
9	2	J-NUT Wide Range
10	4	M8 - 1.25 X 13mm Nut
11	2	Stake Pocket Bracket 11 GA Steel
12	2	J-NUT Short Range
-	1	Installation Instructions

### Tools Required

- Ratchet Wrench
- Torque Wrench
- M8 Hex Socket
- T40 TORX Internal Driver
- Safety Glasses
- Utility Knife
- Drill
- 1mm and 6.4mm Drill Bits
- 25.4mm Hole saw
- Suitable Terminal Pick Tool

© 2025 General Motors. All rights reserved.

**Note:** For vehicles equipped with RPO **UVR** Camera Rearview Mirror. Center the camera image using the mirror control buttons. This will remove the Sports Bar from the image.

### Special Wiring Instructions

P/N	Model Year	Action	Instruction ID
85654295 85654296	2021-prior Incl 2022 LTD RPO J21	No action needed	84219050
85654295 85654296	2022+ Incl 2022 NEW RPO J22	Prior to installation of the sport bar, attach wire extension kit P/N 85630670 per Si Doc ID 6239399.	85625080 

P/N	Model Year	Action	Instruction ID
85625078 85625083	2021-prior Incl 2022 LTD RPO J21	Prior to connecting the wire harness to the UEC, replace the terminal with kit P/N 85625082 by cutting to the wire to length when the wire has been routed into position. Refer to <a href="#">Wire to Wire Repair</a> in Vehicle Service Manual.	84219050
85625078 85625083	2022+ Incl 2022 NEW RPO J22	No action needed	85625080

### Procedure

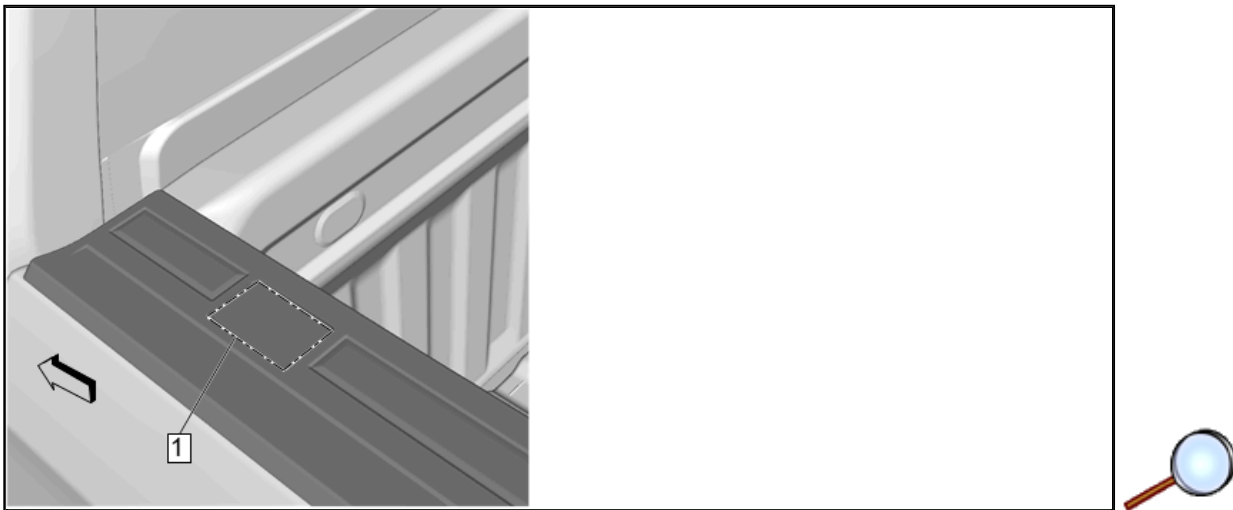

© 2025 General Motors. All rights reserved.

1. Carefully cut the bed rail molding (1) along the rectangular grooves to expose front stake pockets. Repeat for opposite side.

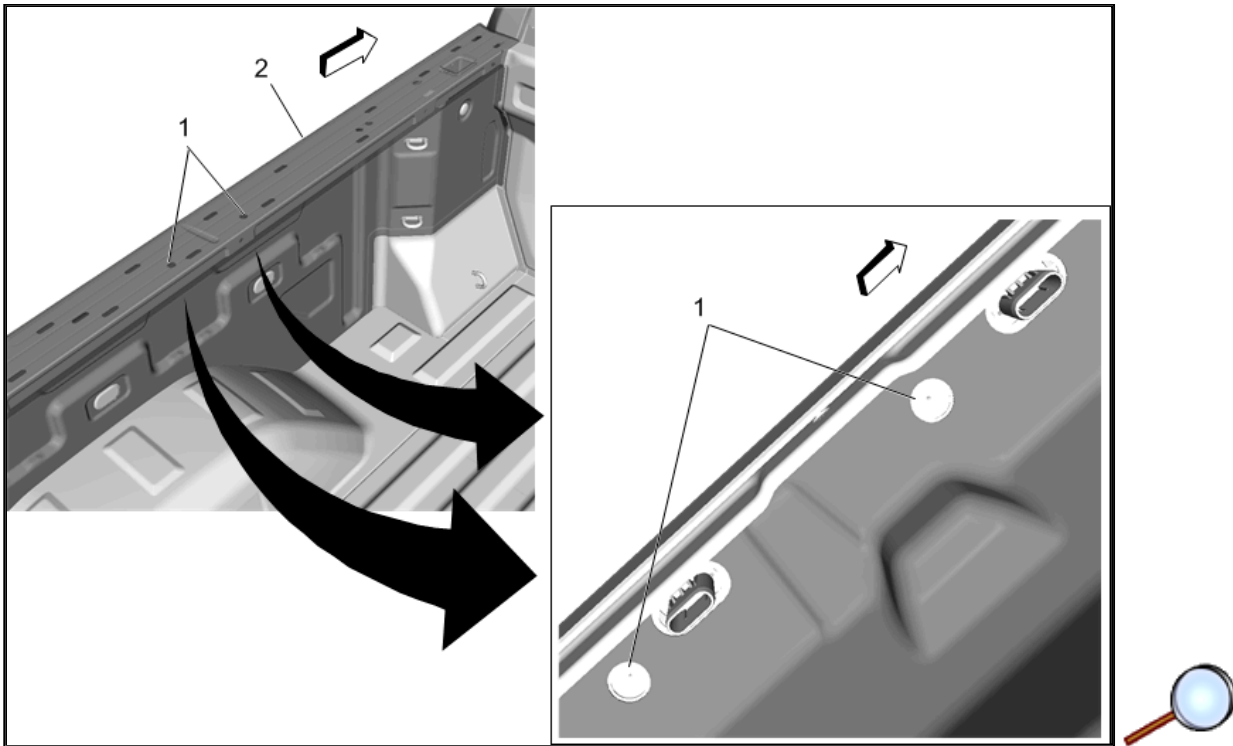

**Caution:** Always check scale, size and position of holes before drilling. Failing to do so may cause damage to the vehicle, misalignment of components or the inability to install the accessory.

- Carefully cut holes in the left bed rail molding (2) by drilling 6.4mm pilot holes (from the underside) using the 1 mm pilot locators (1) on the bed rail moldings, seen through the 10.5 mm holes on the underside of the bed rail. Move to the topside of the bed rail and enlarge the holes in the bed rail molding using the 25.4mm hole saw. Proceed carefully and do to not drill through the steel box below.

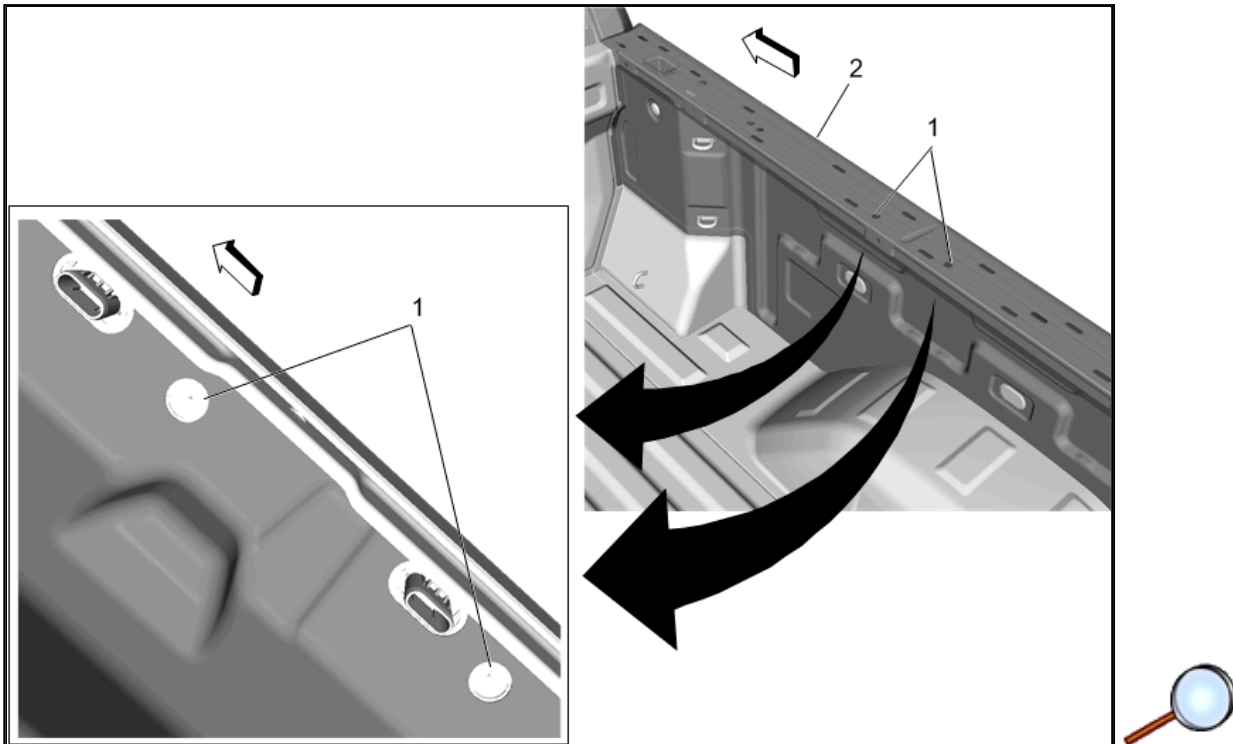

- Carefully cut holes in the right bed rail molding (2) by drilling 6.4mm pilot holes (from the underside) using the 1 mm pilot locators (1) on the bed rail moldings, seen through the 10.5 mm holes on the underside of the bed rail. Move to the topside of the bed rail and enlarge the holes in the bed rail molding using the 25.4mm hole saw. Proceed carefully and do to not drill through the steel box below.



**Caution:** Use the correct fastener in the correct location. Replacement fasteners must be the correct part number for that application. Fasteners requiring replacement or fasteners requiring the use of thread locking compound or sealant are identified in the service procedure. Do not use paints, lubricants, or corrosion inhibitors on fasteners or fastener joint surfaces unless specified. These coatings affect fastener torque and joint clamping force and may damage the fastener. Use the correct tightening sequence and specifications when installing fasteners in order to avoid damage to parts and systems.

4. Install J-Nut (6) (Item 9 in kit contents) to Stake Pocket Bracket (4) (Item 11 in kit contents). Install the M8 J-Nut (5) (Item 12 in kit contents) in the Stake Pocket Bracket. Mount the Stake Pocket Bracket to the vehicle box using the M8 mounting bolt (1) (Item 4 in kit contents) and Round Nylon Washer (2) (Item 2 in kit contents). Hand tighten bolt while aligning top surface of stake pocket bracket with the top surface of the bed rail molding (3). Repeat for opposite side.

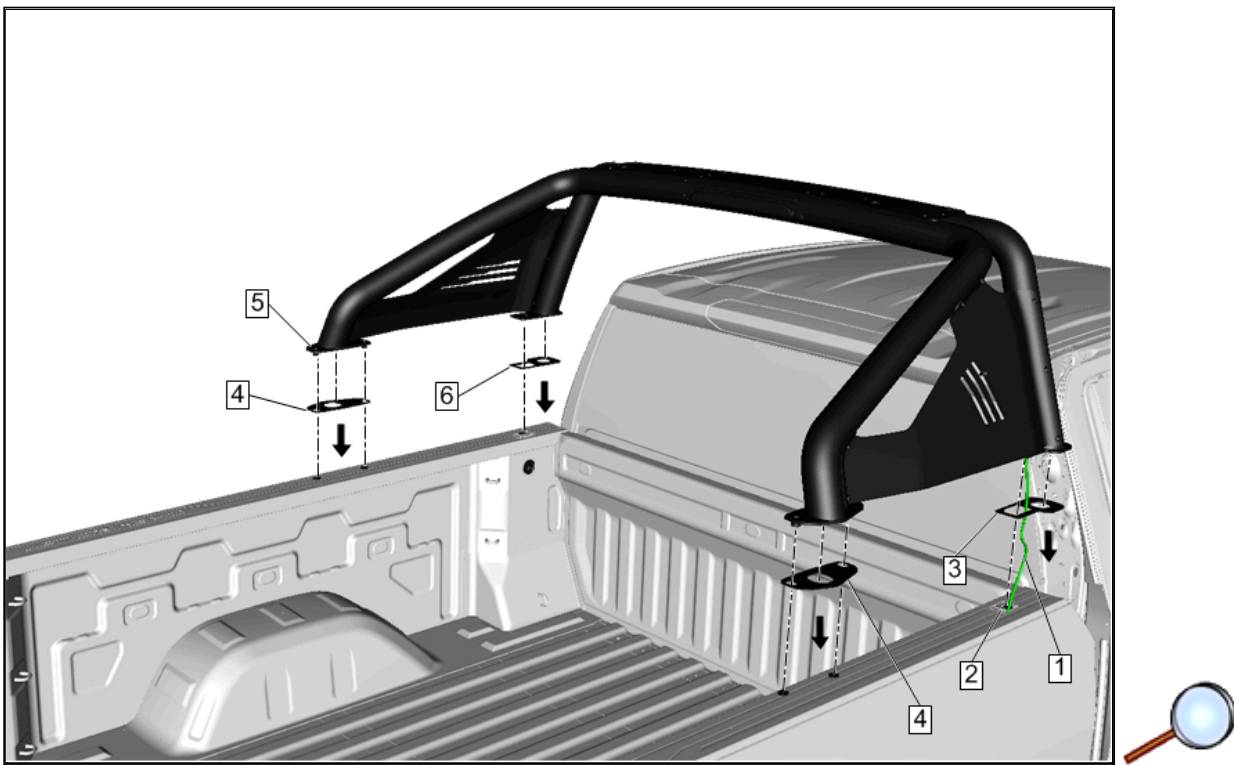

5. Position foam tape pads (3),(4) & (6) (Items 5, 6, 7, & 8 in kit contents) on the bottom surfaces of the sport bar plates (5).
6. Route wiring (1) through the foam tape (3) at the passenger-side forward cutout, past the mounting bracket.
7. Remove backing and apply the adhesive surface of the foam tape to each mounting plate.

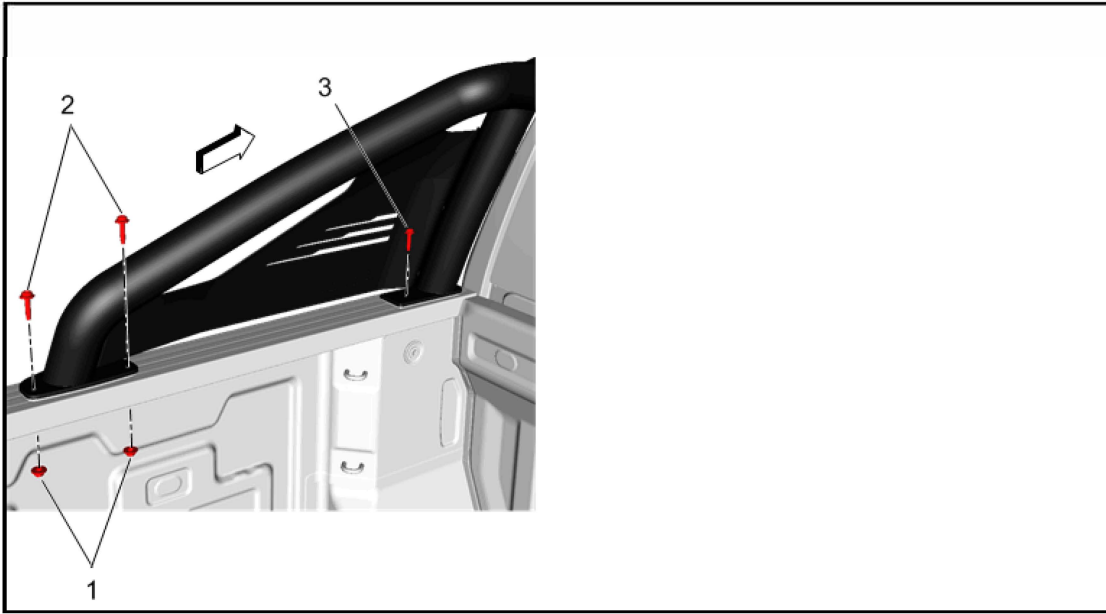

© 2025 General Motors. All rights reserved.

8. Align forward mounting hole in sport bar front mounting plate with mounting hole in the stake pocket bracket. Align the rear mounting plate cylindrical spacer (on bottom) with the holes in the bed cap. Repeat for opposite side.
  9. Install the M8 screw (3) (Item 3 in kit contents) into the cage nut (Item 12 in kit contents) in the stake pocket bracket. Repeat for opposite side.
- Tighten**  
Tighten the M8 screws to 9 N.m (7 lb ft).
10. Install the M8 screws (2) (Item 3 in kit contents) into the two holes on the rear mounting plate. Repeat for opposite side.
  11. Install the M8 nuts (1) (Item 10 in kit contents) onto the M8 screws (2) from the underside of the bed. Repeat for opposite side.

**Tighten**

Tighten the M8 screws and nuts to 9 N.m (7 lb ft).

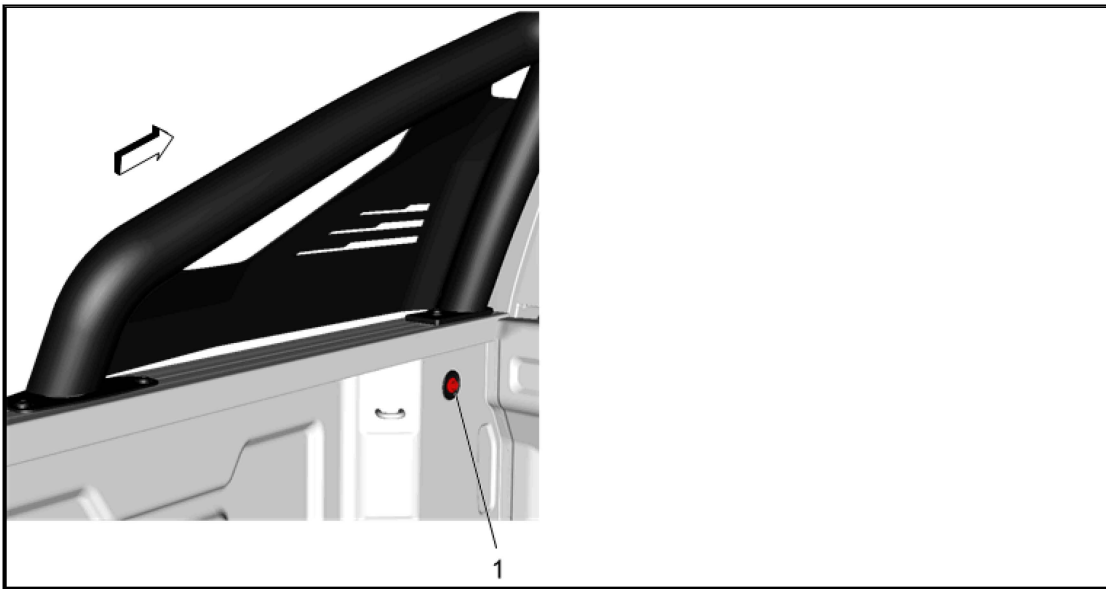

12. Finish tightening the M8 Hex bolt (1) (Item 4 in kit contents) to 22 N m (16 lb ft). Repeat for opposite side.

## Sport Bar Harness Installation

### Preliminary Procedure

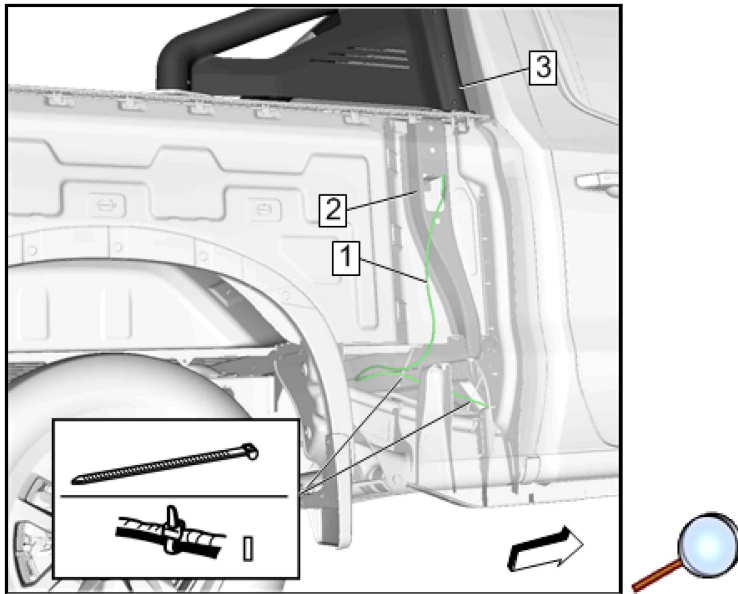

1. The wiring for the Bar comes pre-installed. When the Sport Bar (3) is positioned to the pickup truck bed, the wire harness (1) from the sport bar gets inserted into the front right stake pocket (2), and half way down the stake pocket it comes out and continues down to the ground.
2. Guide wire harness (1) into the passenger side front stake pocket (2) between the inner and outer panels of the truck bed, lower sport bar assembly (3) onto the pickup box.
3. Secure the portion of the harness extending below the truck bed to the Chassis harness.
4. Ensure the routing is snug but NOT tight. Use the enclosed zip ties to secure the harness.
5. Continue Installing the Sport Bar per Installation Instructions.

### **Underbody / Front Harness Installation**

1. Disconnect the negative battery cable. Refer to [Battery Negative Cable Disconnection and Connection](#) in Vehicle Service Manual.
2. Remove the right front wheel and tire assembly. Refer to [Tire and Wheel Removal and Installation](#) in Vehicle Service Manual.
3. Remove the right front wheel house liner. Refer to [Front Wheelhouse Liner Replacement](#) in Vehicle Service Manual.

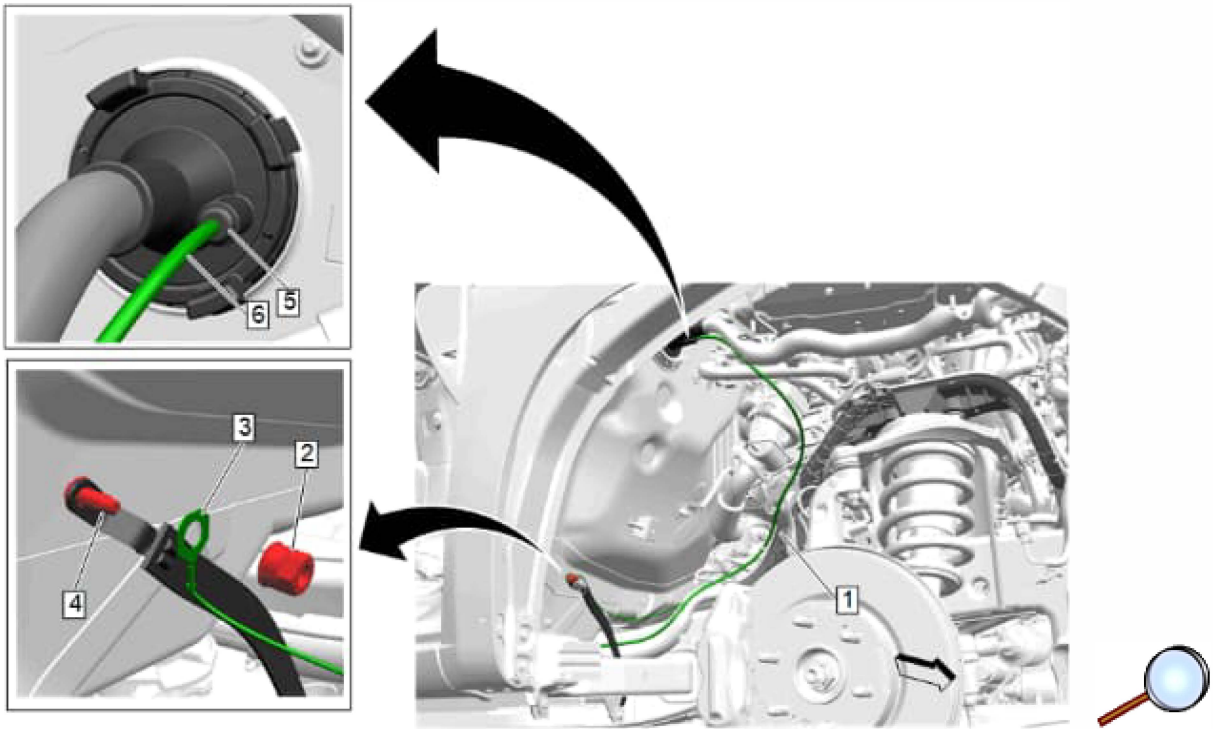

**Note:** Make sure the new eyelet stays in the six o' clock position and away from other wires before tightening ground bolt.

4. Remove the existing ground bolt (2), stack the new eyelet (3) to ground stud (4) and replace the ground bolt, tighten the ground bolt to 23 N.m (17 lb ft).
5. On the provided harness locate the Foil Tape, this needs to align with High Temp Protection (1) on the Harness in the Engine Compartment.
6. Locate the wire pass through grommet (5) on the passenger side plenum.
7. Puncture the pass through grommet (5), using care not to create a larger than necessary hole.
8. Using a fish wire, push the purple wire of the accessory harness (6) through the grommet (5). The wire will come out of the front lower insulator under instrument panel.

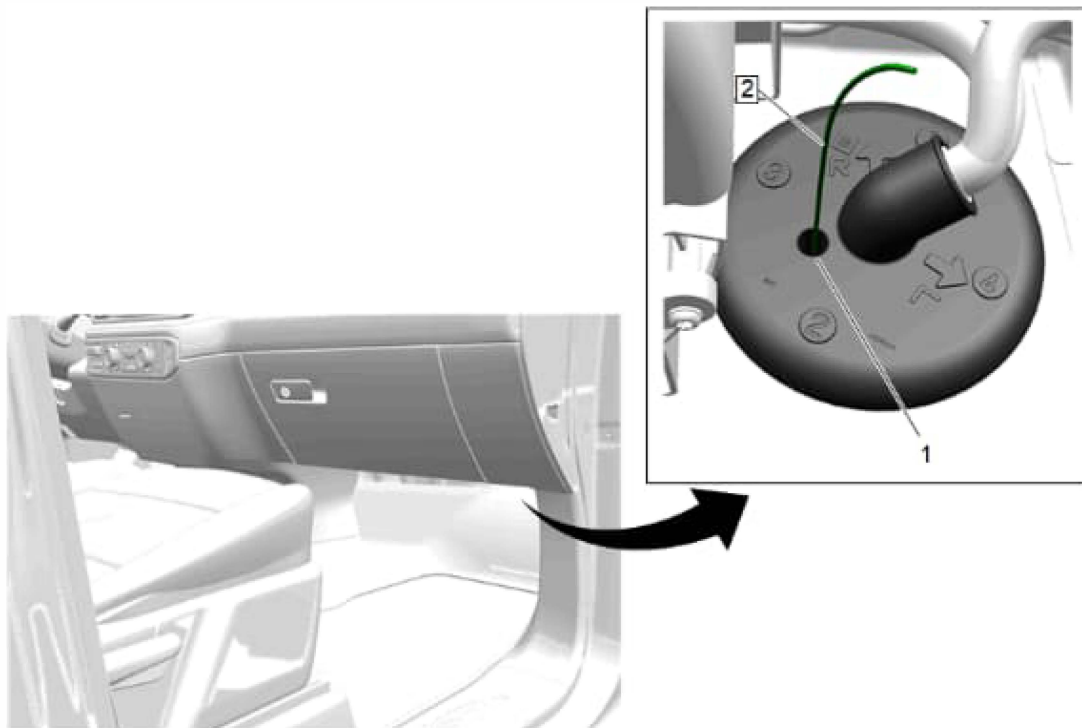

9. Continue to pull the wire (2) through the grommet hole (1).

**43/53 Cab (Crew/Double Cab) - Locate the X370 (B) - Connector Cavity 17**

**1. For vehicles equipped with RPO GF2, GF5, GFF and GPZ.**

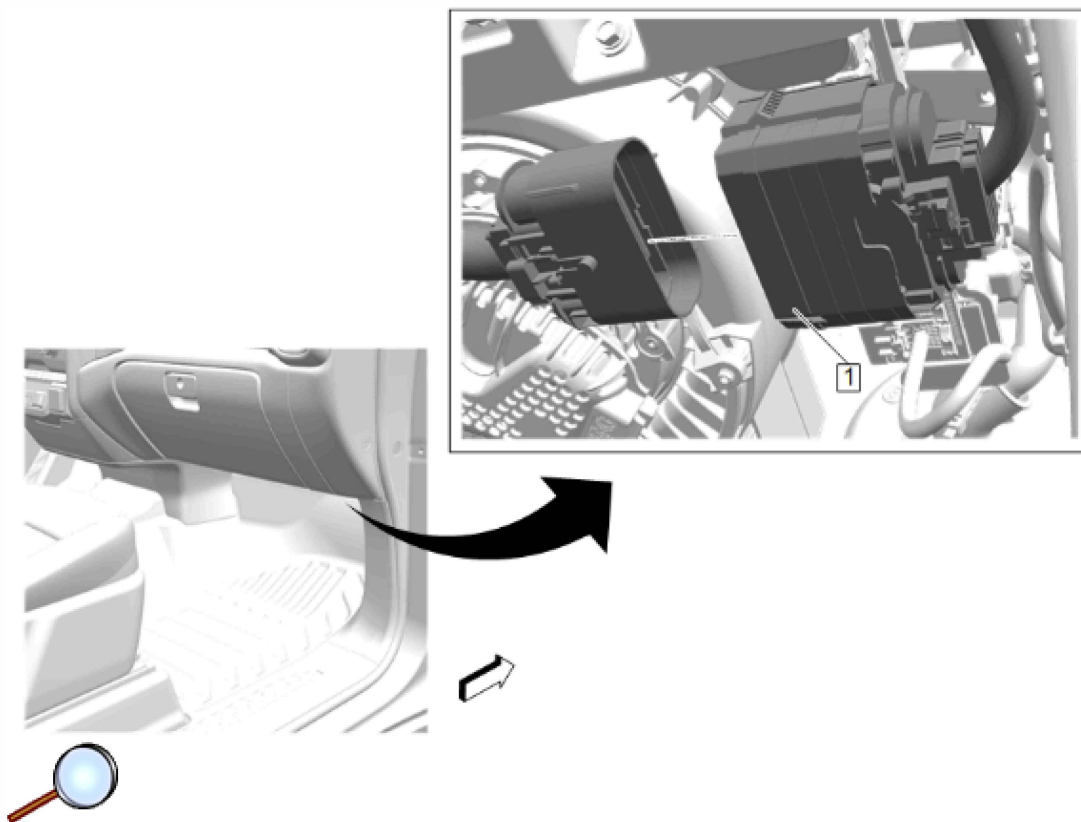

- 1.1. Locate and disconnect the I/P headliner side (1) of inline **X370 (B)** connector.
- 1.2. On the headliner side of the inline connector (1), remove the wire dress cover. Refer to 55 Way Connector at the end of these instructions.

**Note:** Below is the X370(B) connector image.

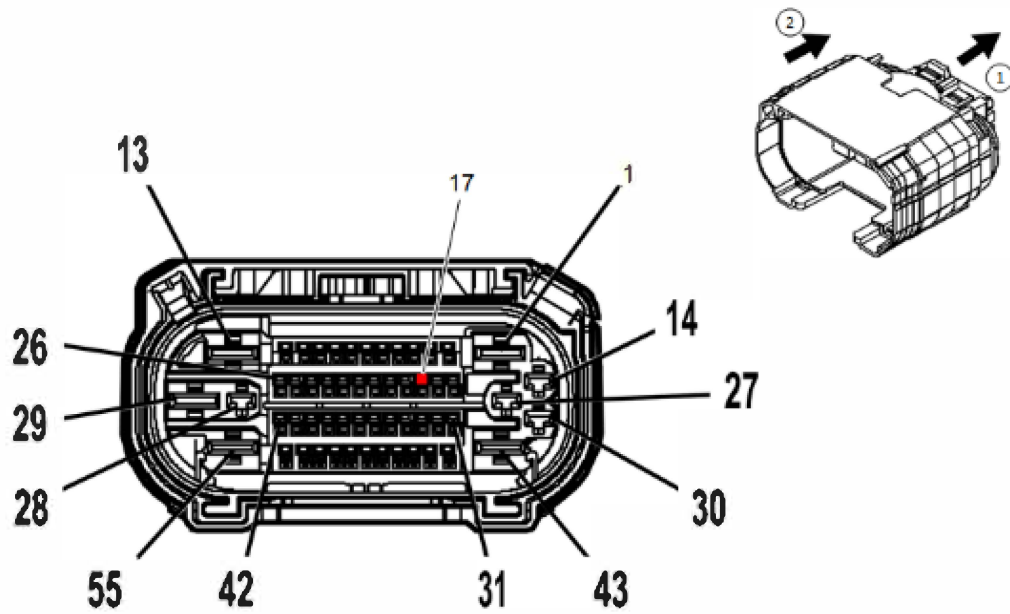

**Note:** Do not cut off the terminal that was removed, the vehicle owner may want to return to the original CHMSL

- 1.3. Using the appropriate terminal pick tool, remove the terminal from **connector X370 cavity 17**.
- 1.4. Continue to pull wire through grommet and route wire.

### 03 Cab (Standard Cab) - Locate the X370 (B) - Cavity 8 or X211 Cavity 32

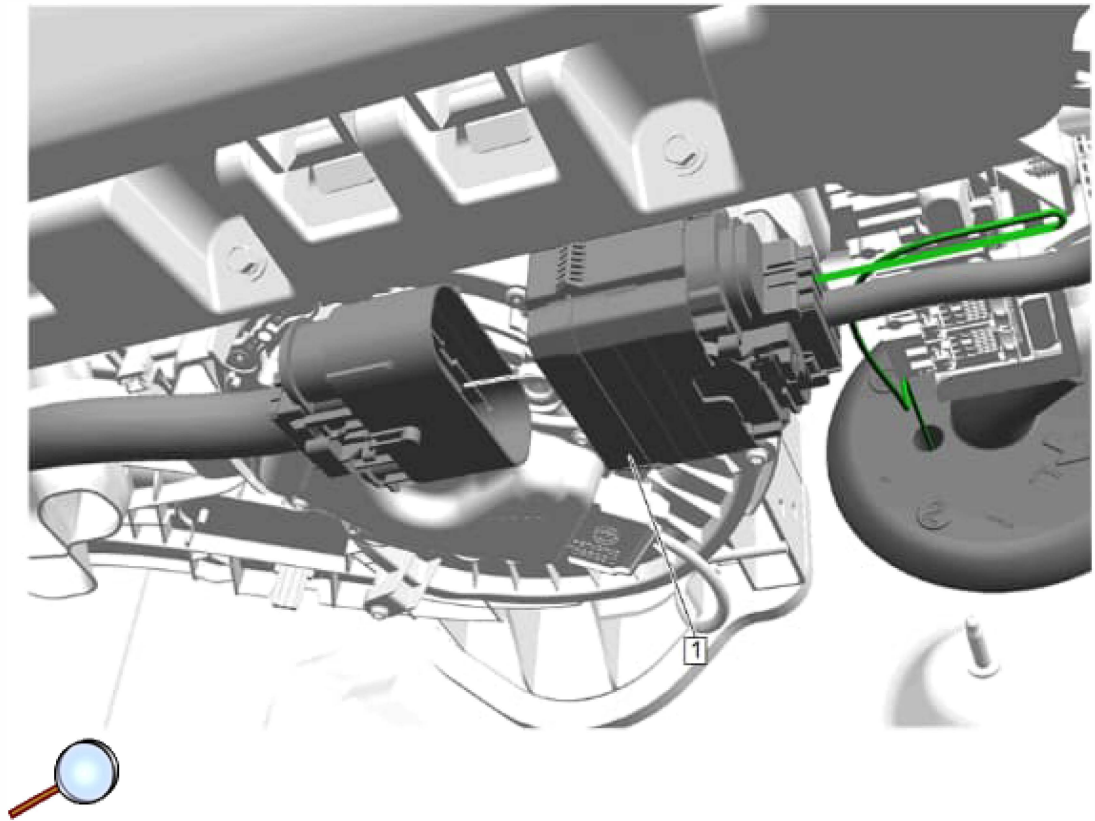

**Note:** For vehicles equipped with RPO **GF5** and **GFF** (GMC) the **X211 connector or X370B cavity 8** is located behind the passenger side kick panel.

- 1.4.1. Reassemble the X370 55-way connector (1) and reinstall. Refer to 55 Way Connector at the end of these instructions.
- 1.4.2. Secure the terminal lead to the existing harness every 50mm (2.0 in.) with zip ties. Trim excess off zip ties.

**Note:** Below is the X211 connector image.

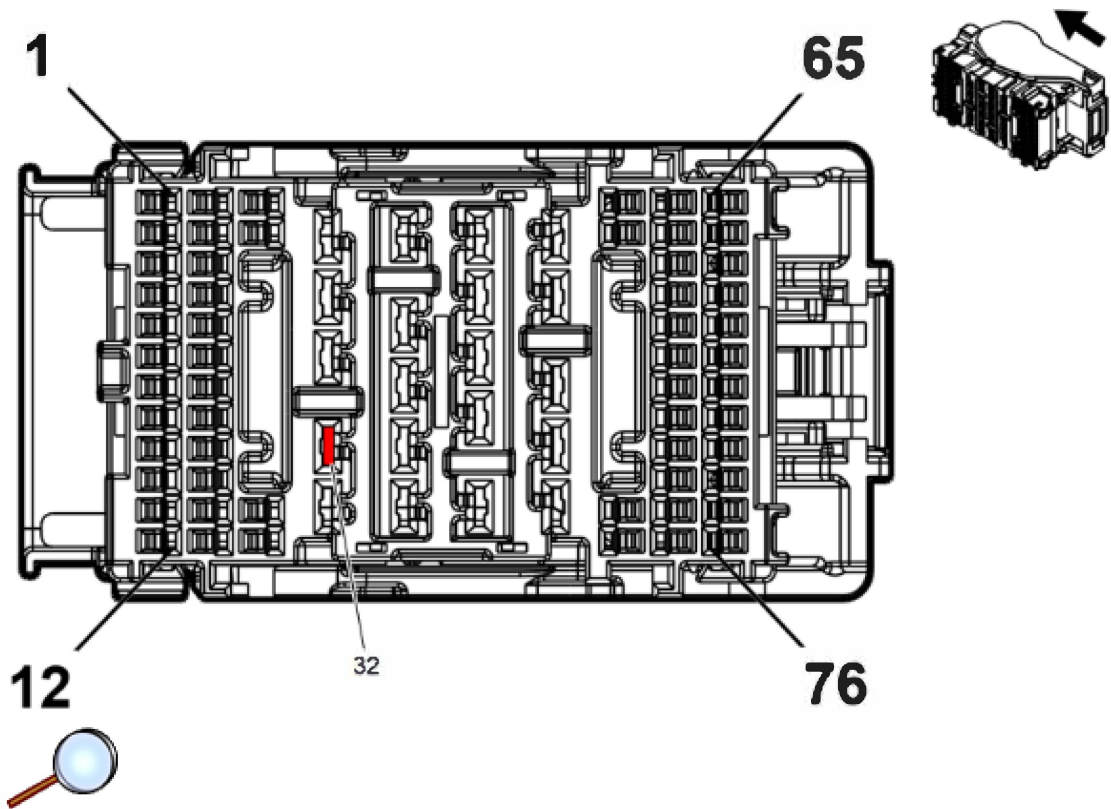

**Note:** Below is the X370(B) connector image.

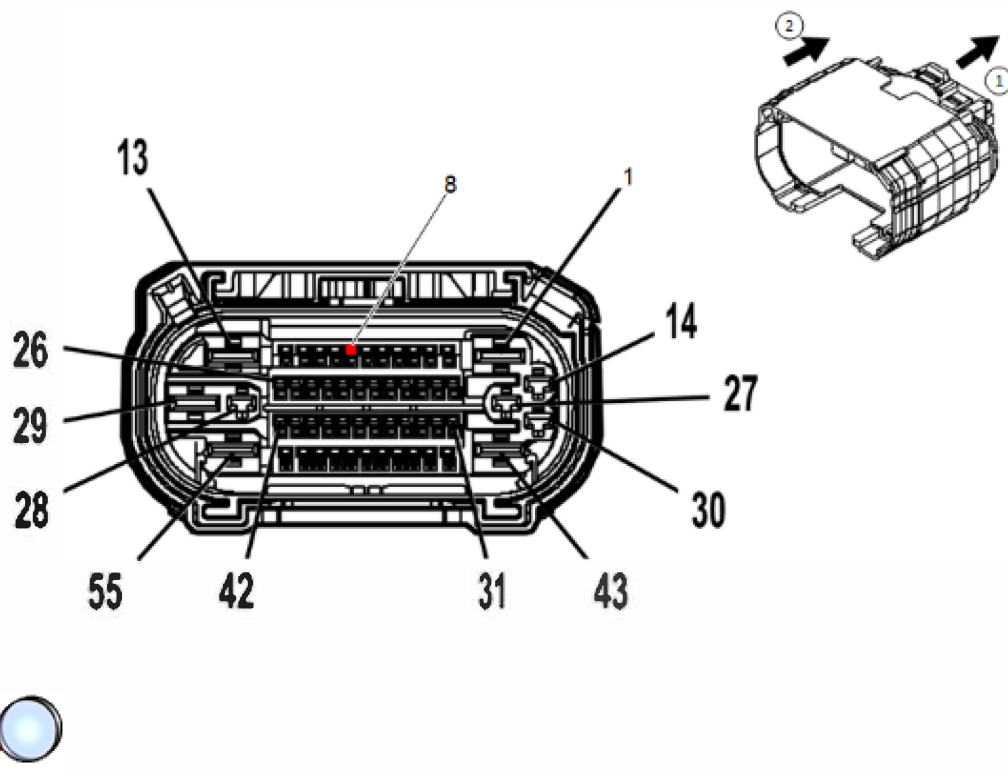

**Note:** For vehicles equipped without RPO **GF2**, **GFF**, **GF5**, **GPZ** (Chevrolet) and **GFF** (GMC):

- 1.5. If the vehicle is 03 CABs- Remove circuit 1053 from cavity 18 In the IP Inline connector which mates to the body connector at X370A . Insert X370A going to the accessory CHMSL.
- 1.6. If the vehicle is 43/53 CABs - Remove circuit 820 from cavity 33 in the IP Inline connector which mates to the body connector at X370A. Insert going to the accessory CHMSL.
- 1.1. Remove the instrument panel extension. Refer to [Instrument Panel Extension Replacement](#) in Vehicle Service Manual.

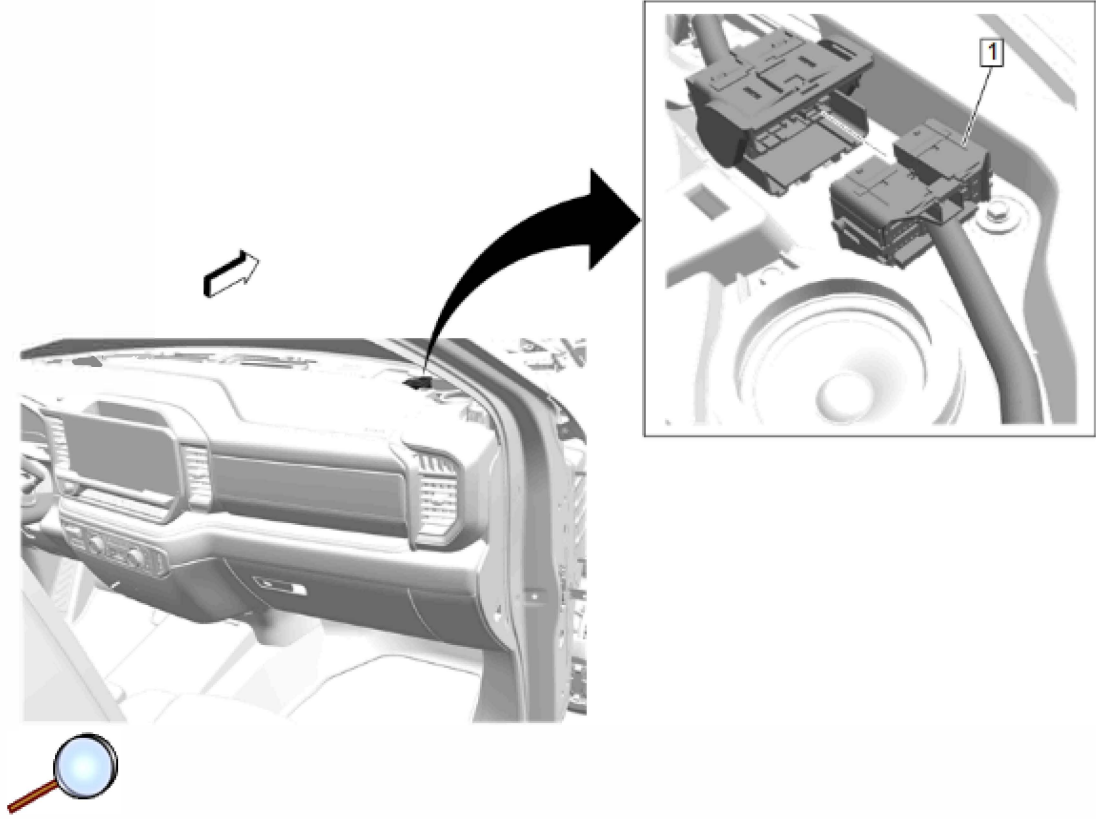

- 1.2. Locate and disconnect the **X370A connector** (1) near the right instrument panel speaker and locate **cavity 18 (for 03 CABs) and cavity 33 for (43/53)**.

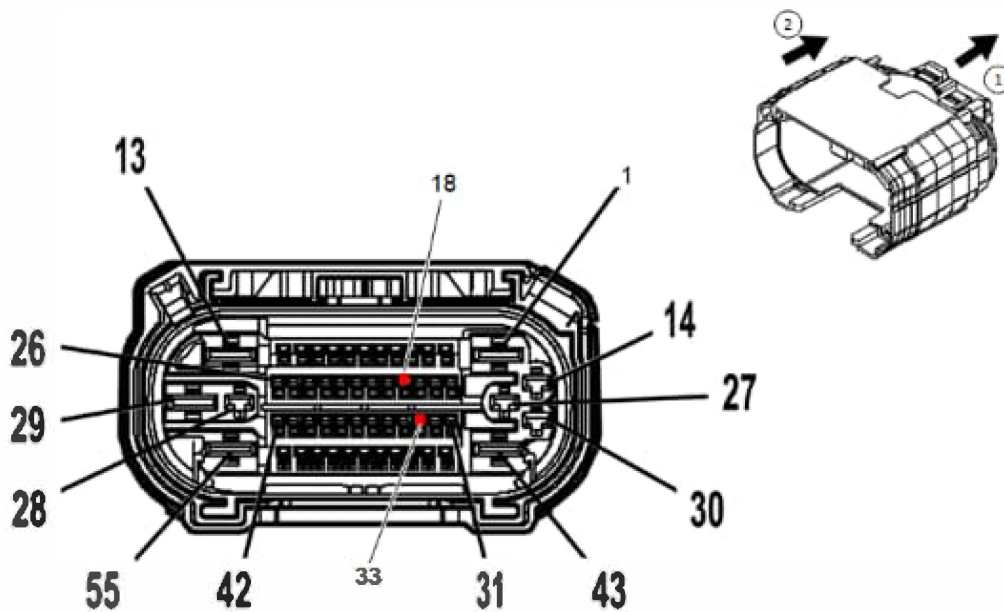

**Note:** Do not cut off the terminal that was removed, the vehicle owner may want to return to the original CHMSL

- 1.3. Using the appropriate terminal pick tool, remove the terminal from cavity 18 (03 CABs) or 33 (43/53) and tape back the lead.
- 1.4. Continue to pull wire through grommet and route wire towards right instrument panel speaker continuing to connector X370A and insert terminal into cavity 18 (03 CABs) or 33 (43/53).

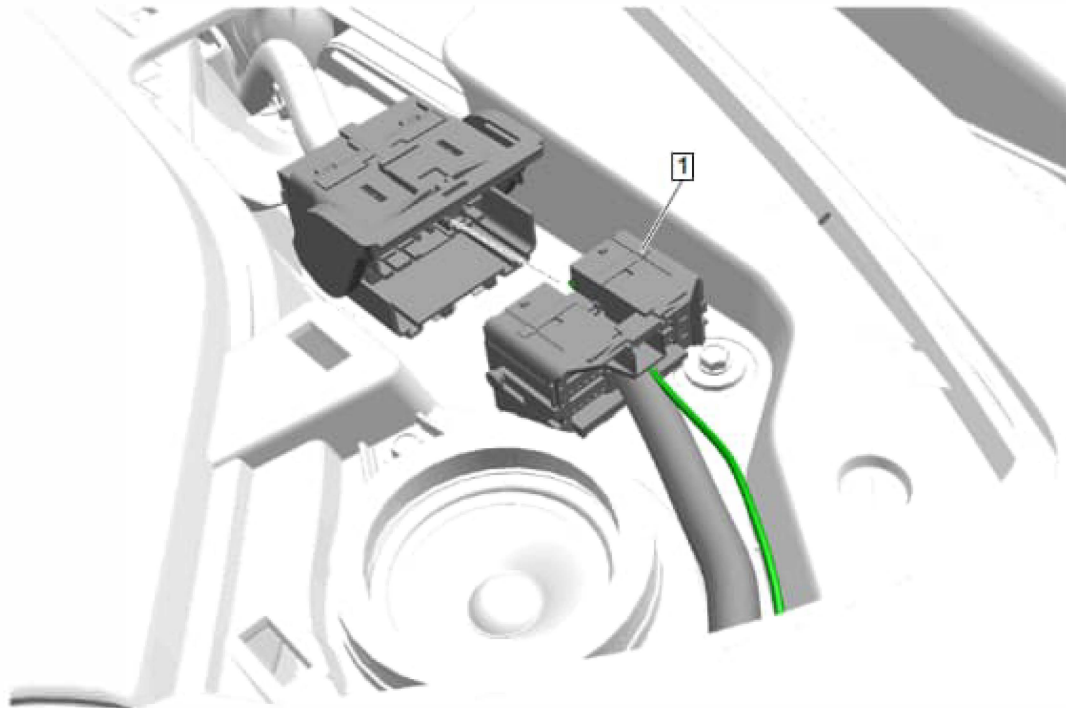

- 1.5. Re-connect X370A connector (1).
- 1.6. Secure the terminal lead to the existing harness every 50mm (2.0 in.) with zip ties. Trim excess off zip ties.

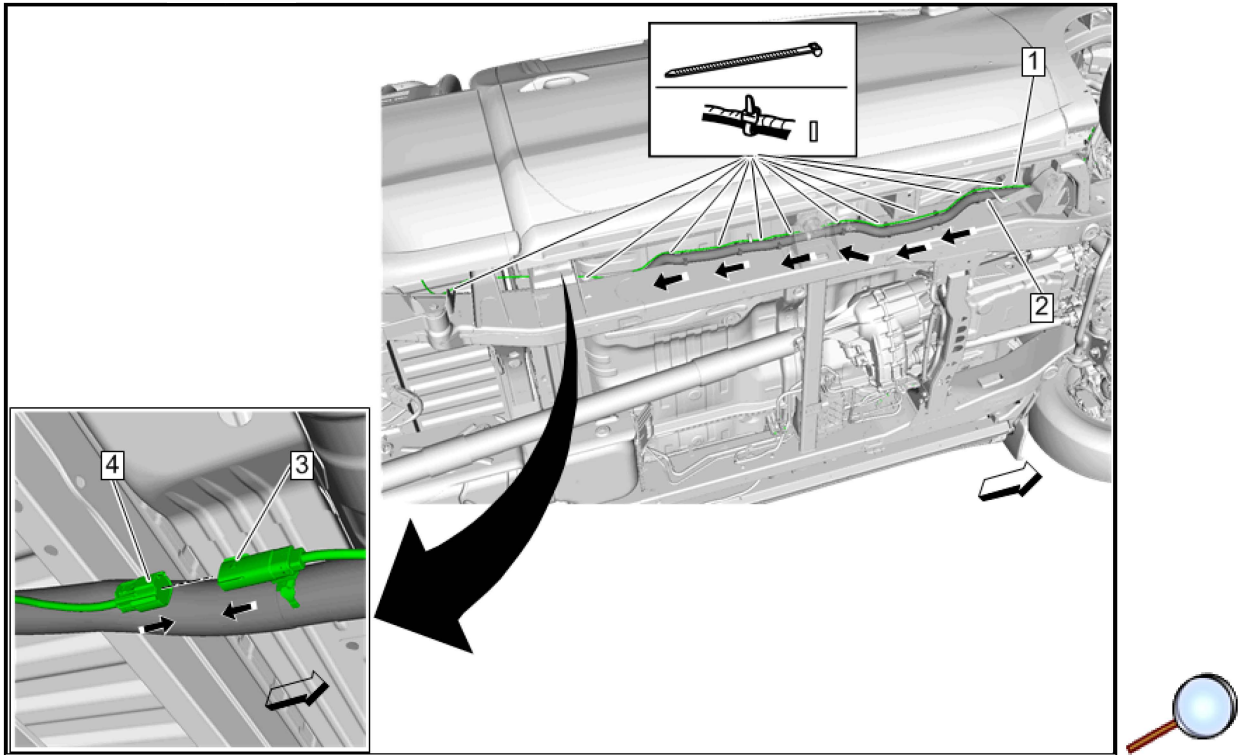

2. Make the connection between the CHMSL (4) and Underbody / Front Harness (3) Use the included Zip Ties every 200 mm to secure the harness (1) to the chassis harness (2) and to take up any excess length. Trim excess off zip ties.
3. Connect the negative battery cable. Refer to [Battery Negative Cable Disconnection and Connection](#) in Vehicle Service Manual.
4. Test the CHUMS, operation.
5. Reinstall the instrument panel extension, if removed. Refer to [Instrument Panel Extension Replacement](#) in Vehicle Service Manual.
6. Install the right front wheel house liner. Refer to [Front Wheelhouse Liner Replacement](#) in Vehicle Service Manual.
7. Install the right front wheel. Refer to [Tire and Wheel Removal and Installation](#) in Vehicle Service Manual.

## 55 Way Connector

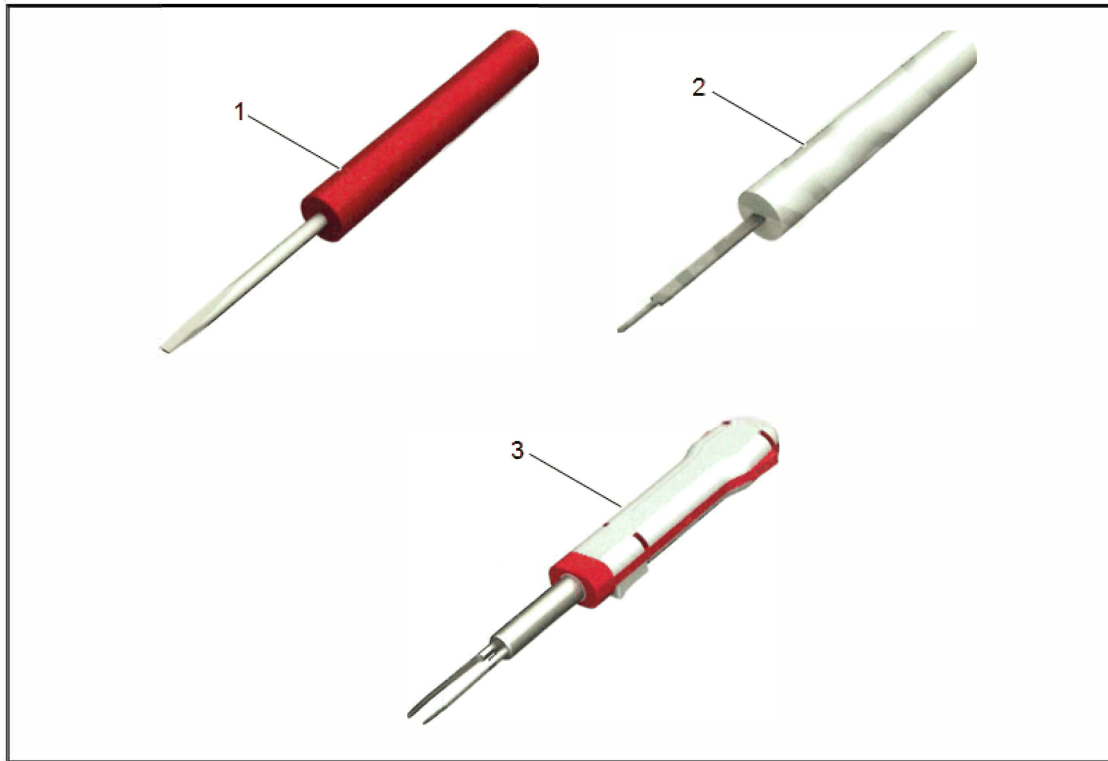

### Recommended Tools

Item	Description
1	Pocket Screwdriver
2	Terminal Tool P/N J-38125-215A
3	Terminal Tool P/N J-38125-36

### Wire Dress Cover Replacement (Release Slide From Pre-Stage)

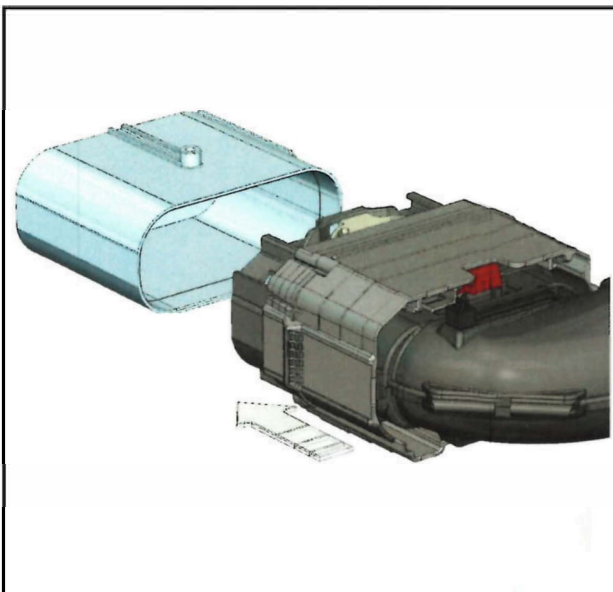

1. Insert connector onto fixture to release the slider.

---

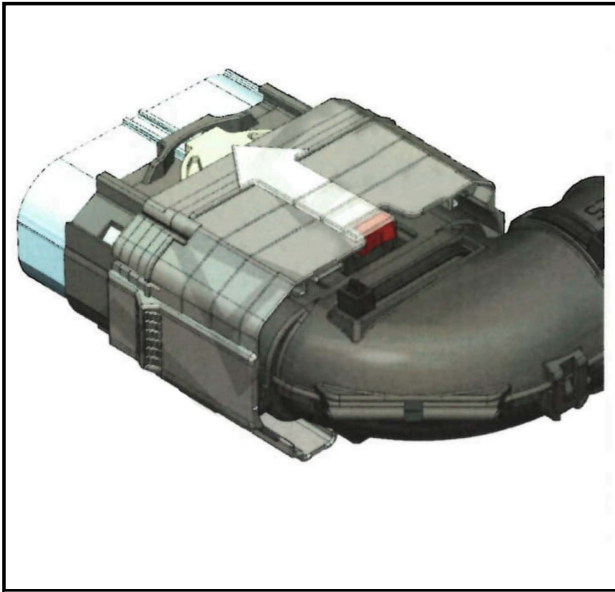

2. Once connector is properly seated, slide the slider forward.



3. Slider is now in full-stage position.

## Remove Wire Dress Cover

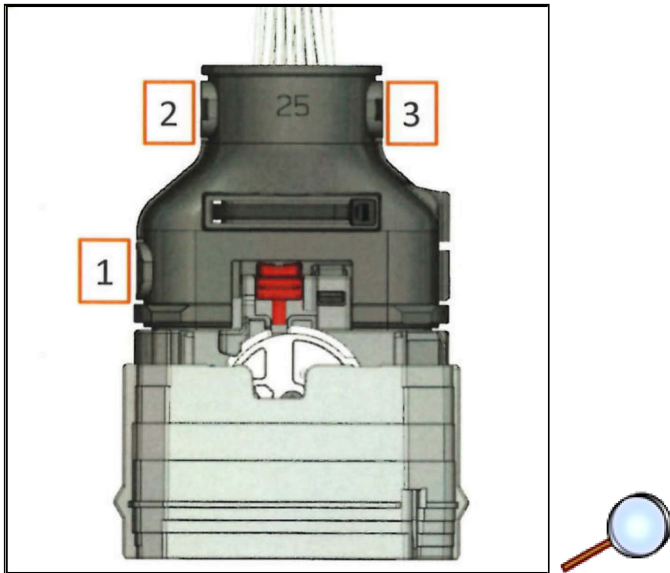

1. Locate the wire dress cover locks.

**Note:** Numbers indicate the locks release sequence.

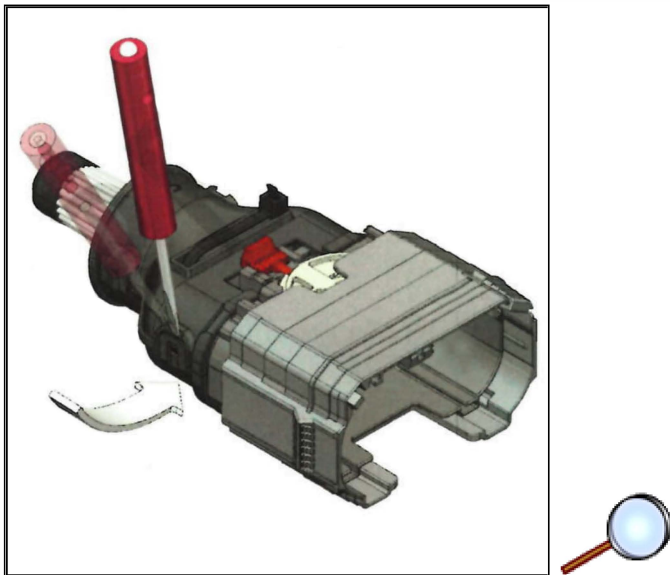

2. Place pocket screwdriver between the rams and locking tab, deflect them with the tool to release them, one at a time, and open the wire dress cover.

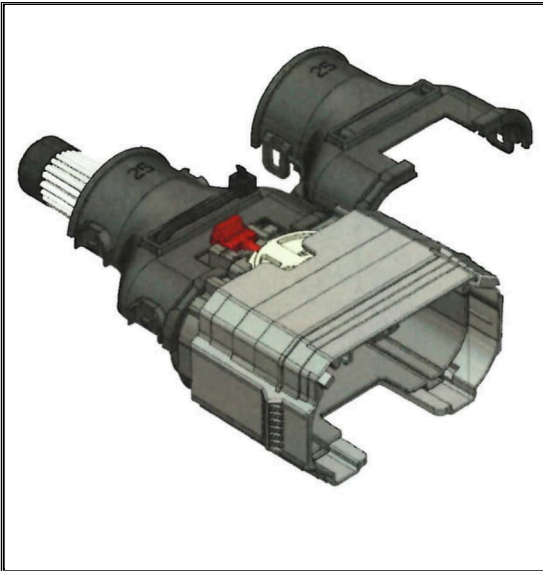

3. Open wire dress cover.



4. Locate and remove the coverings and the wire tie.

**Note:** Be careful not to damage the cable insulation.

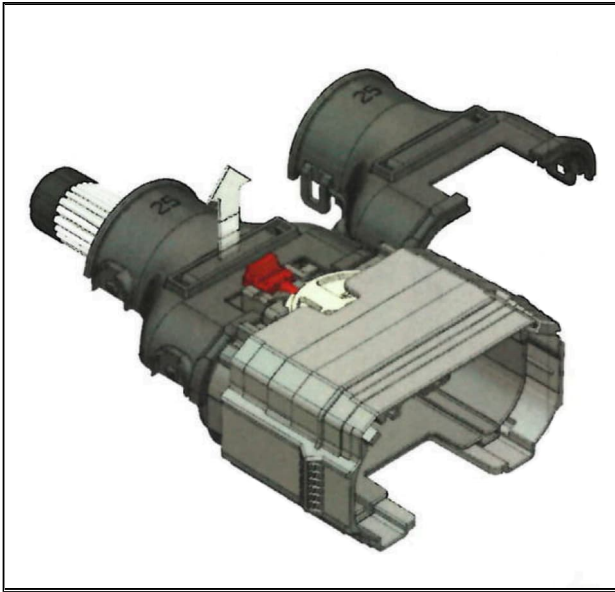

5. Remove wire dress cover from assembly.  
**Move Slider Back to Pre-Stage**

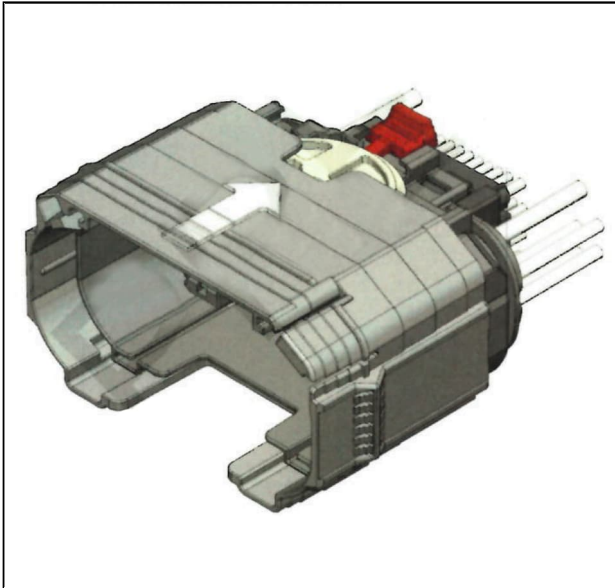

1. At this stage, slider can be pushed backward to place it in Pre-Stage. **OPTIONAL:** This step can also be performed after the terminal removal process.

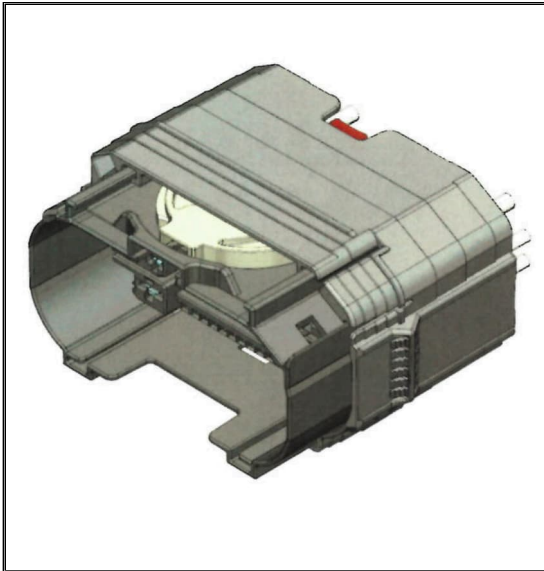

2. Verify audible “click”.

3. Slider is now in Pre-Stage position.

**Female Terminal Replacement (Move Lock Secondary to Pre-Stage)**

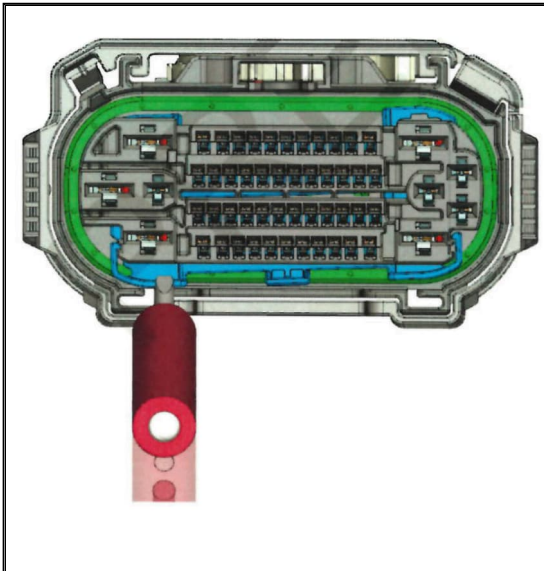

1. Place the tip of P/N pocket screwdriver over the lock secondary rib and push it down.

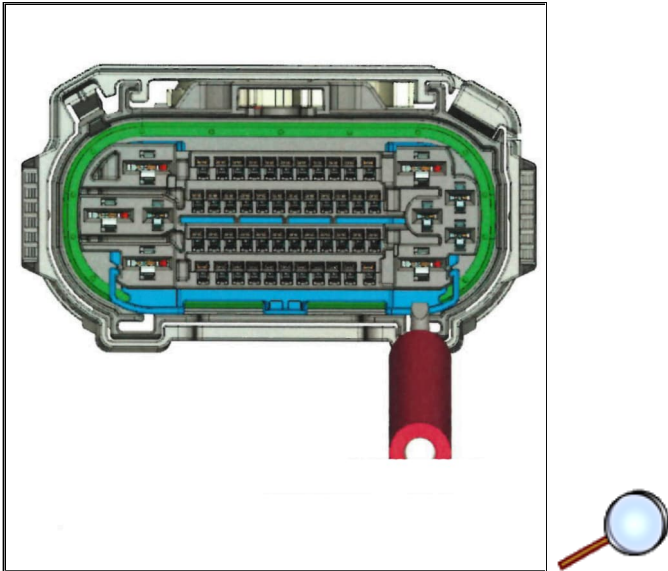

2. Repeat the process with the remaining lock, be careful as not to damage the lock secondary.
3. Lock secondary is now in Pre-Stage position.

**Terminal Identification OCS 1.2 / Cavity Plug**

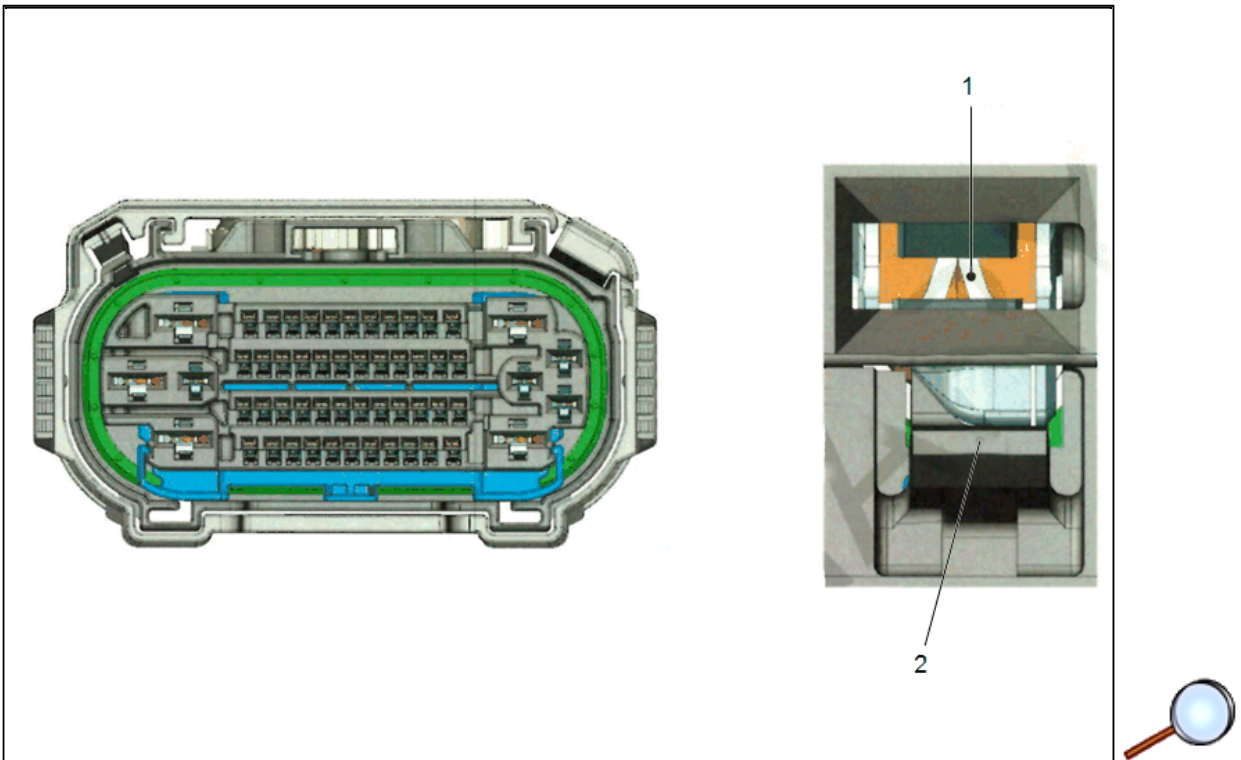

1. Terminal (1).
2. Flex Lock (2).

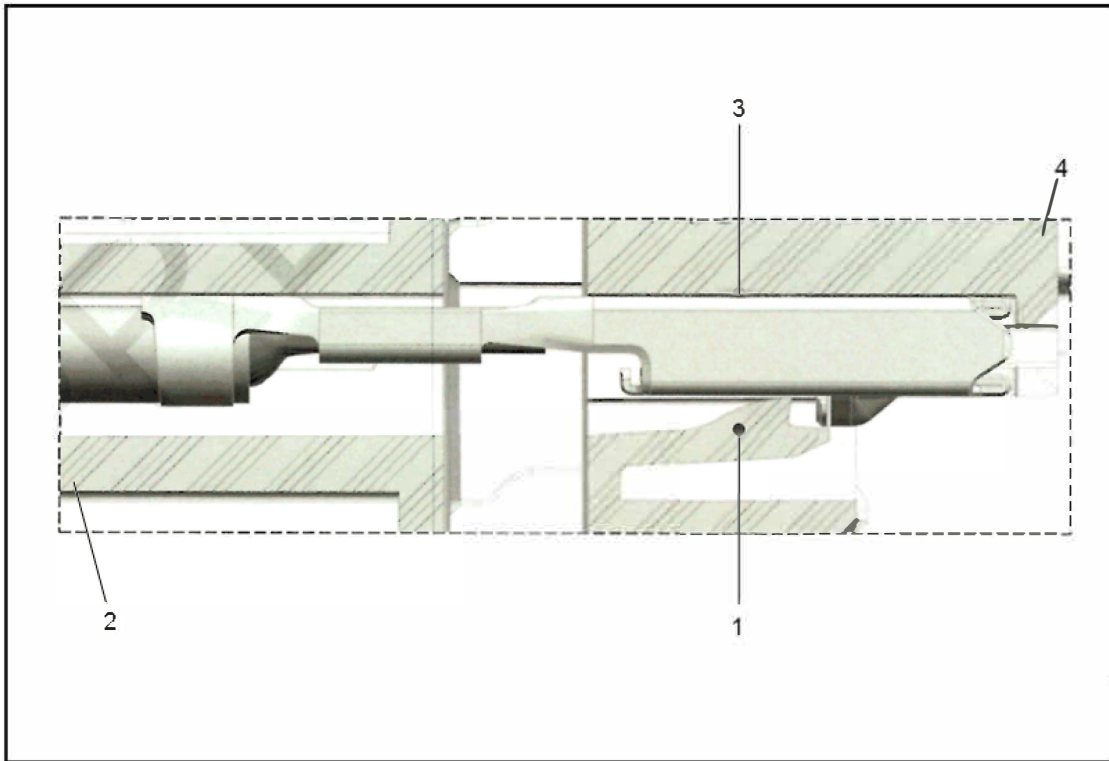

- 3. Flex Lock (1).
- 4. Cable End (2).
- 5. Terminal (3).
- 6. Mating End (4).

**Terminal Removal OCS 1.2 / Cavity Plug**

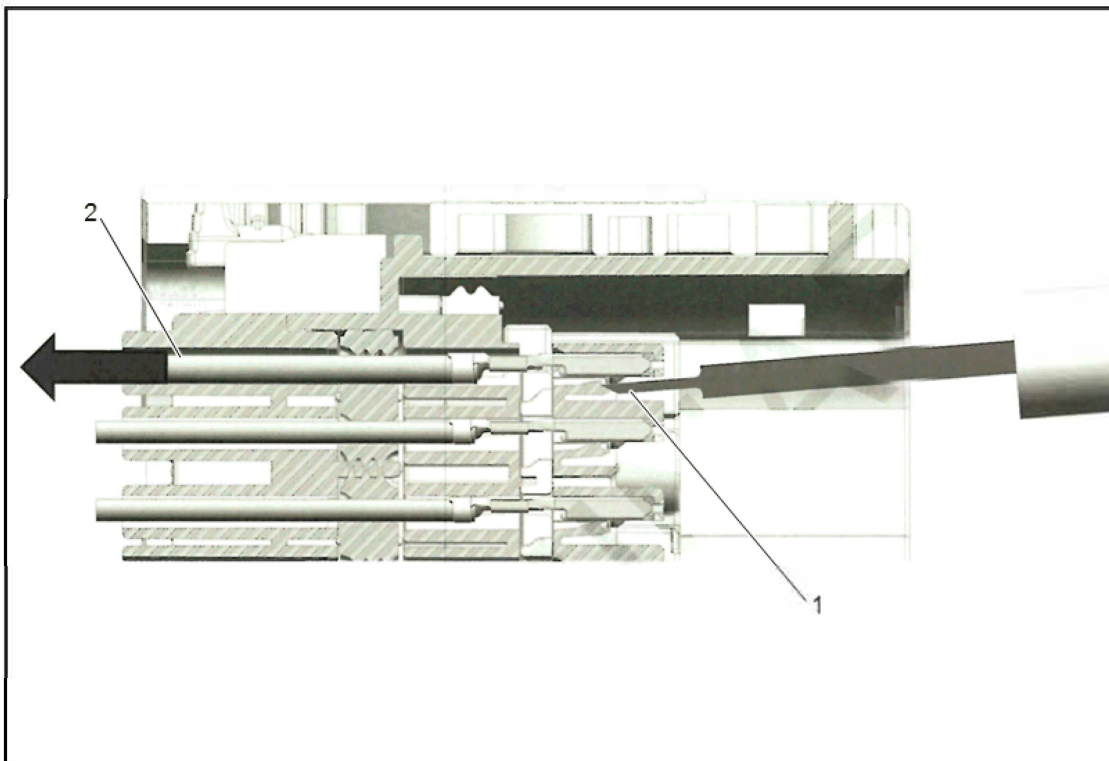

- 1. Locate the flex lock at the front of the connector. Insert tool (1) P/N J-38125-215A straight into the window.
- 2. Deflect the flex lock to unseat the terminal / cavity plug and gently pull on the cable or back of plug (2) to remove the terminal / cavity plug from the receptacle

**Terminal Identification CTS 2.8 and 6.3**

**1. Terminal CTS 2.8:**

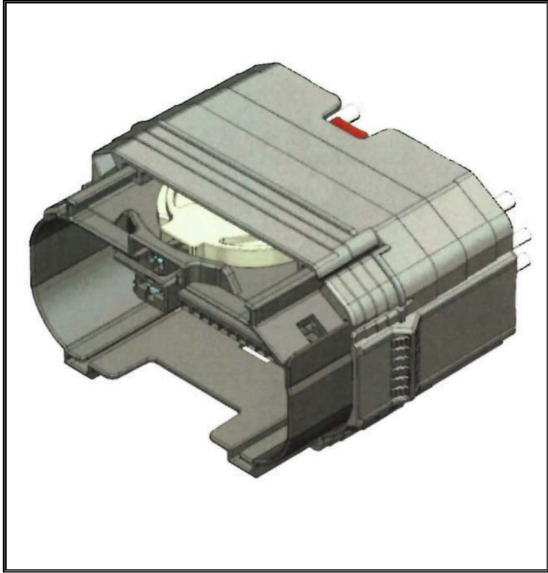

- Removal Windows (1).
- Terminal Tangs (2).

**2. Terminal CTS 6.3:**

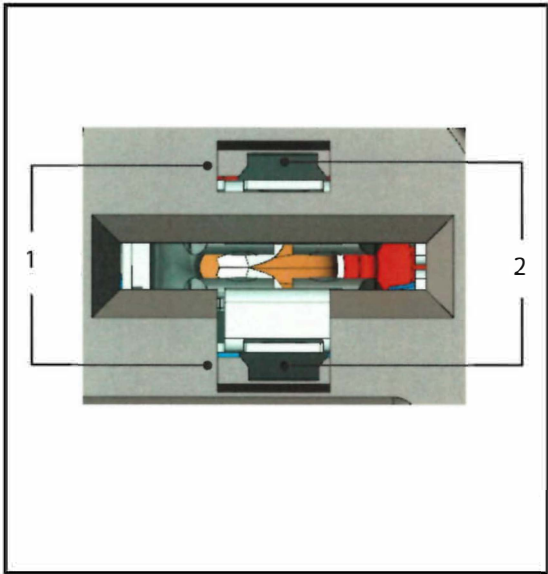

- Removal Windows (1).
- Terminal Tangs (2).

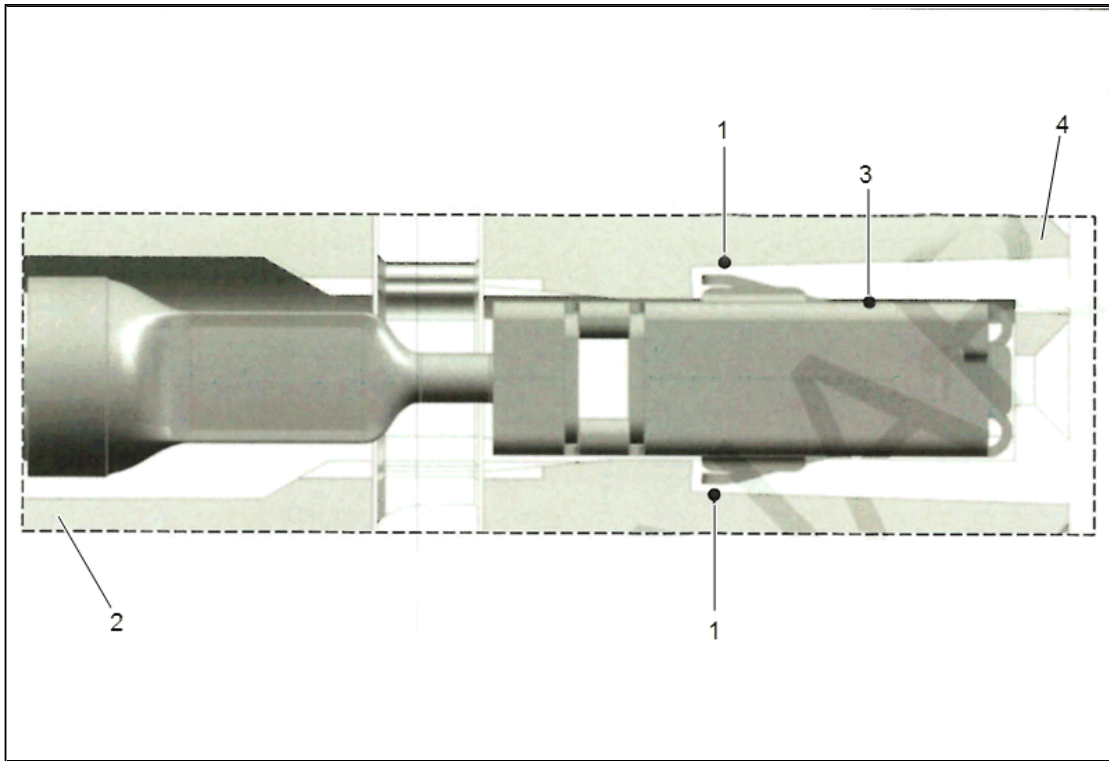

- 3. Terminal Tang (1).
- 4. Cable End (2).
- 5. Terminal (3).
- 6. Mating End (4).

**Terminal Removal CTS 2.8 and 6.3**

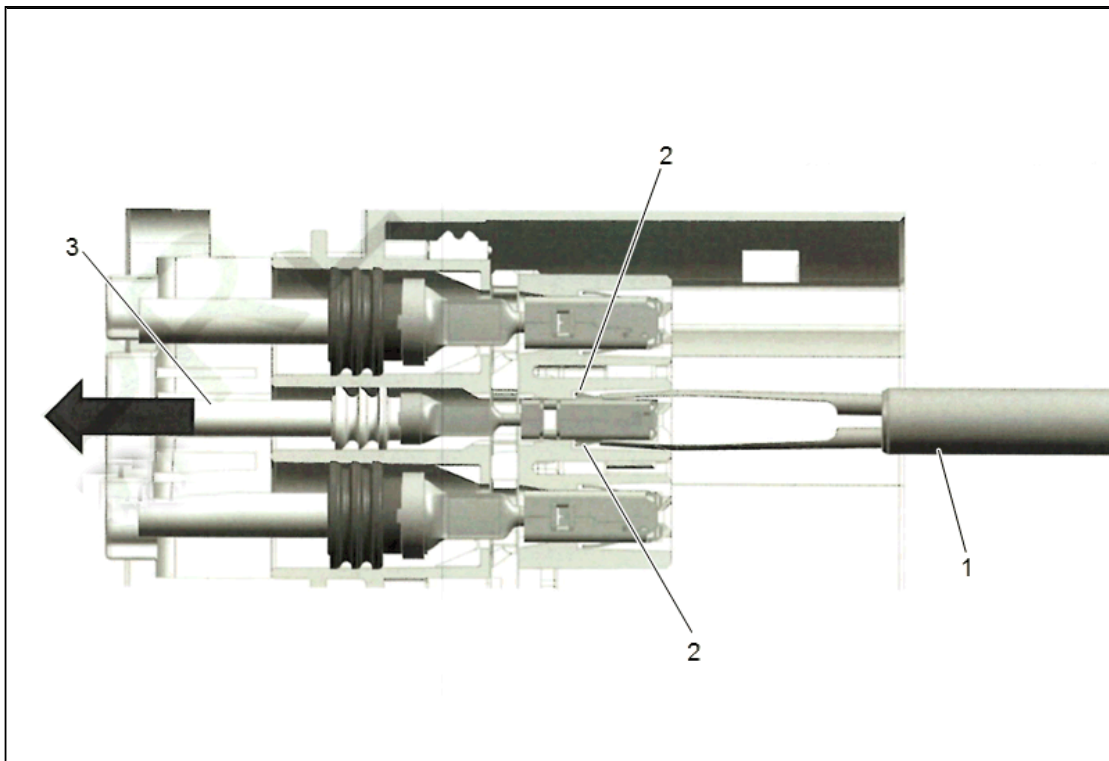

- 1. Locate terminal tangs (2) at the front of the connector.
- 2. Insert tool (1) P/N J-38125-36 straight into the removal windows, deflect the terminal tangs to unseat the terminal and gently pull on the cable (3) to remove the terminal from the receptacle.