

# Front Fender Mud Guard Package Installation

## [Installation Instructions Part Number](#)

86778397

Please read instructions thoroughly before starting.

### Kit Contents

Qty	Description
1	Left Hand Splash Guard
1	Right Hand Splash Guard
2	Screw
2	Washer
6	Rivet
1	Instruction Sheet

### [Special Tools](#)

- T15 Torx Screwdriver
- 5mm (13/64") Drill Bit/Drill
- Awl
- Clean Cloth/Rag
- Rivet Gun
- Isopropyl Alcohol

### [Procedure](#)

1. Remove the front wheel and tire assembly. Refer to [Tire and Wheel Removal and Installation](#) in Vehicle Service Manual.
2. Clean and degrease body panel where splash guards are to be located.
3. Using isopropyl alcohol, clean area where tape will contact body panel.

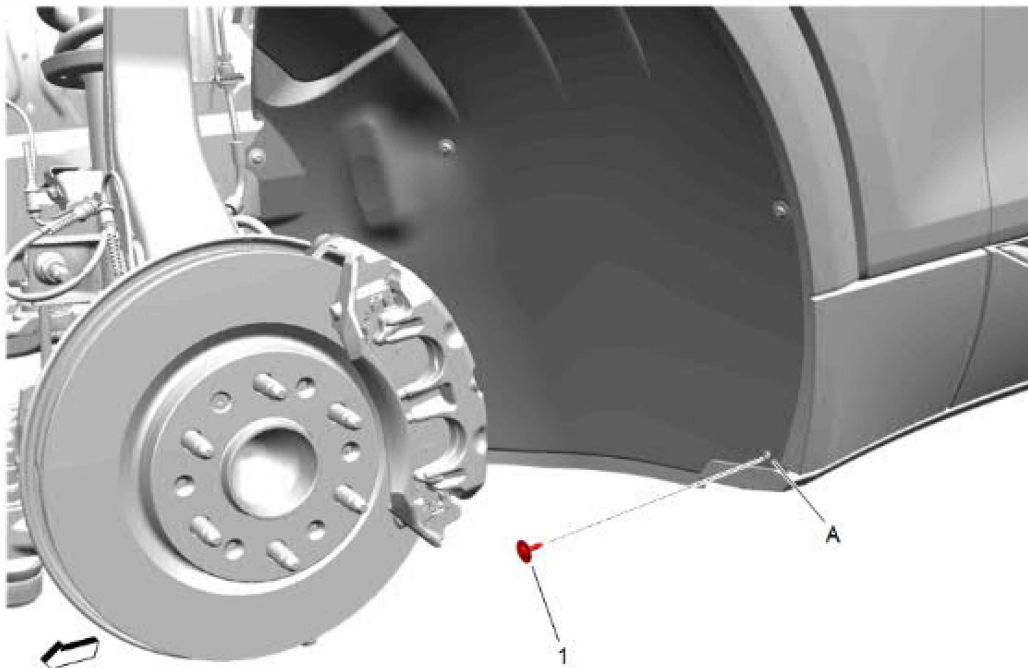

4. Remove and discard existing screw (1) at location (A) and discard.

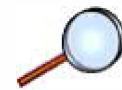
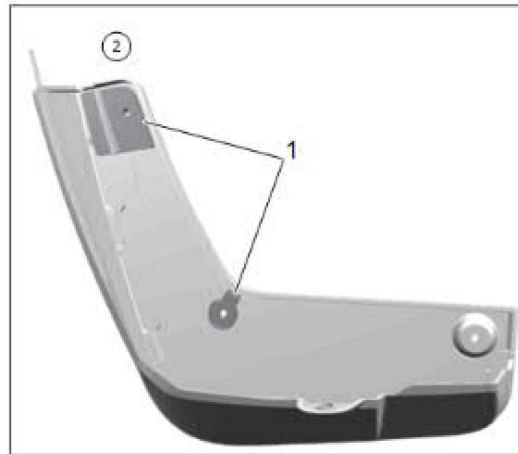
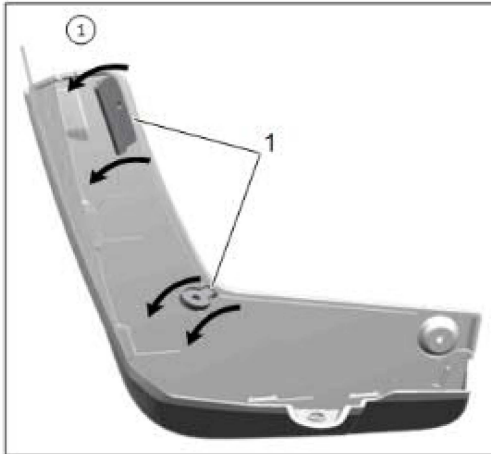

5. Make sure foldable hinges (1) are folded into place.

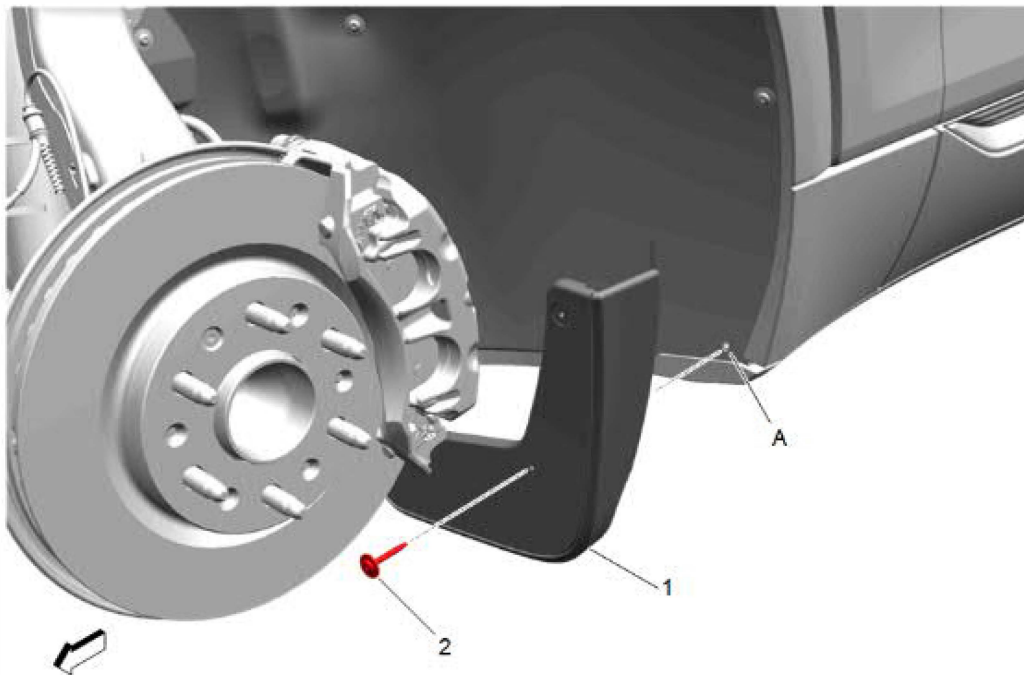

**Caution:** Use the correct fastener in the correct location. Replacement fasteners must be the correct part number for that application. Fasteners requiring replacement or fasteners requiring the use of thread locking compound or sealant are identified in the service procedure. Do not use paints, lubricants, or corrosion inhibitors on fasteners or fastener joint surfaces unless specified. These coatings affect fastener torque and joint clamping force and may damage the fastener. Use the correct tightening sequence and specifications when installing fasteners in order to avoid damage to parts and systems.

6. Place the splash guard (1) to the vehicle, take care to remove any gaps and Install supplied screw (2) and washer at location **(A)**.

**Tighten**

Tighten screw to 3.0 N.m (2.0 lb ft)

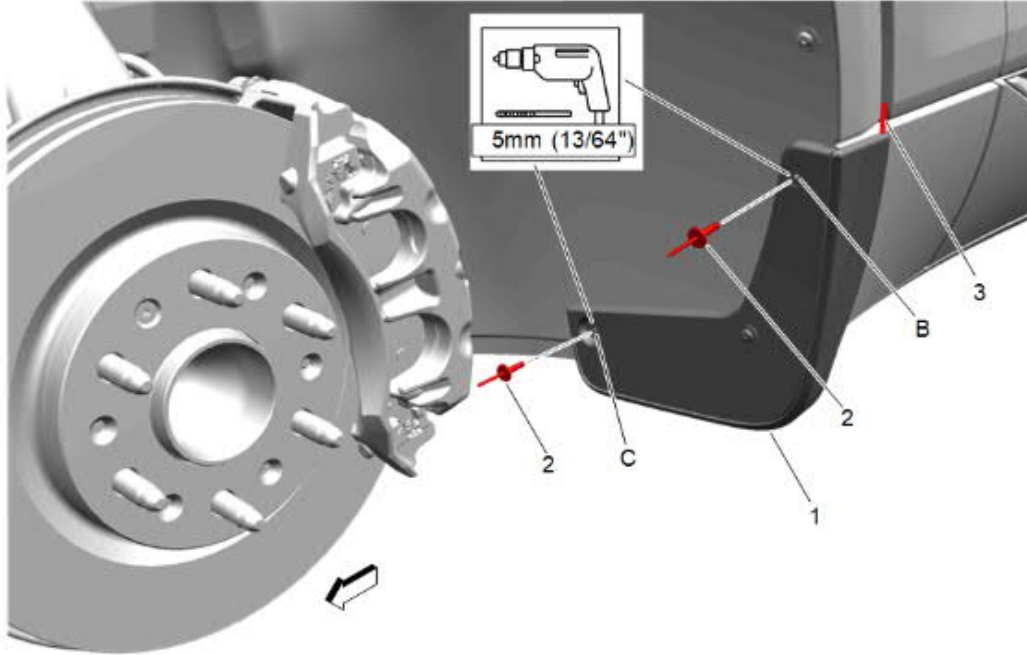

**Caution:** Always check size and position of all holes before drilling. Failing to do so may cause damage to the vehicle, misalignment of components or the inability to install the accessory.

7. While holding the splash guard (1) to the vehicle, take care to remove any gaps and making sure the red tape pull tab (2) is accessible, carefully drill a 5.0 mm (13/64") hole at locations (B) and (C) and install supplied rivets (2) at these locations on splash guard (1).

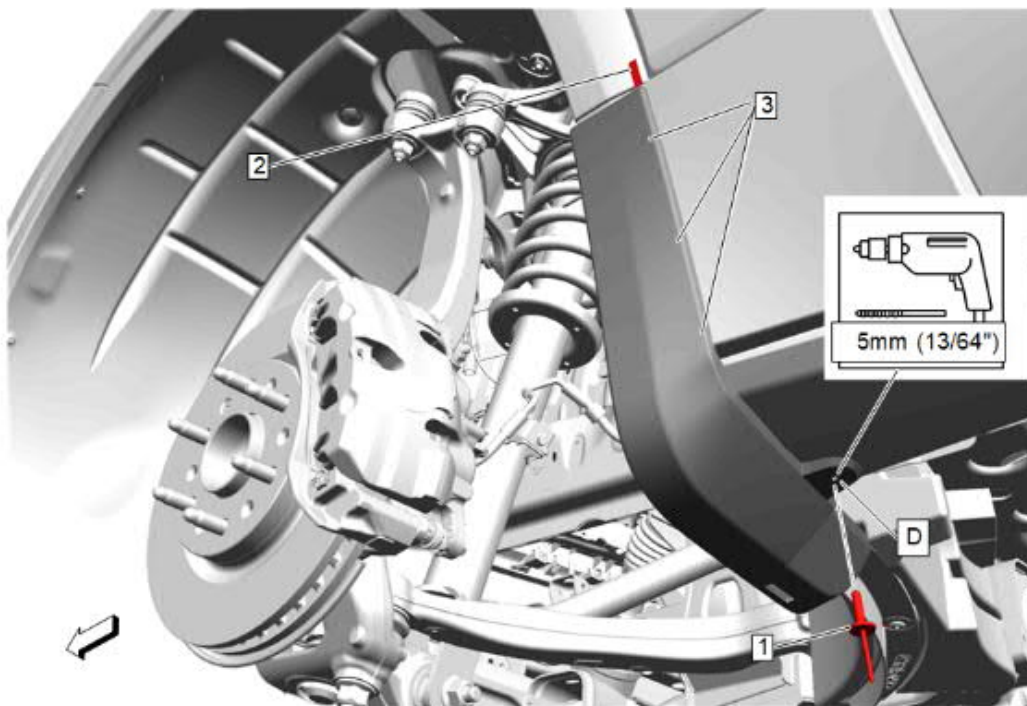

8. While holding the splash guard tightly to the vehicle to ensure there are no gaps, carefully drill a 5.0 mm (13/64") hole at location (D) and install supplied rivet (1) at this location on splash guard.
9. Remove tape pull tab (2) and apply firm pressure to the splash guard (3) along the tape line to adhere the tape to the fender. Hold the firm pressure for a minimum of 60 seconds to properly adhere the tape.
10. Install the front wheel and tire assembly. Refer to [Tire and Wheel Removal and Installation](#) in Vehicle Service Manual.
11. Repeat procedure for other side.
12. Guards can be cleaned with any commercially available cleaner.