

Hood Decal Package Installation

Installation Instructions Part Number

86782388

To enable a successful installation of decals please refer to 52524.01V Accessory Decal Installation Tips and Tricks at <https://techtube.gallervideo/detail/video/5991123051001/52524.01v-accessory-decal-installation-tips-and-tricks?autoStart=true&g=decals>

Note: Video is referenced from the GM Tech Tube in Center of Learning.

Hood Decal Package Installation

DESCRIPTION	QUANTITY
Decal - Hood	1
Installation Instructions	1
Plastic Squeegee	1

Tools Required

- 70% Isopropyl Alcohol
- Lint-free towels
- Hair Dryer
- Spray bottle that contains a wetting solution (3 or more drops of unscented liquid detergent mixed with 24 oz. of water)

Note: The decal needs to float on the painted surface for easy positioning, if the adhesive is sticking to the painted surface then add more drops of soap to the spray bottle. Do NOT use Commercial premixed soap solution.

- Plastic Squeegee (Included in the kit)

Note: Only use the included plastic squeegee to work the decals. Using the incorrect squeegee will damage the decals.

- Sewing Needle or Thin Pin

Note: Do NOT use a razor blade.

Important Considerations

Attempting to install a decal dry (without the use of a surfactant) can result in bubbles that will be difficult to remove.

Preparation - Before Installation

1. After opening the kit, check to see if any parts are missing and that the product is not damaged.
2. This product should be installed with proper installation tools.
3. Install this product while observing all warnings and precautions stated in this instruction booklet.
4. **IMPORTANT: Begin with a thoroughly washed vehicle.**
5. Ambient temperature of decals and vehicle must be 70°F / 21°C to 90°F / 32°C at the time of installation and for a minimum of 30 minutes and up to two hours after.
6. Thoroughly clean vehicle surface with 70% isopropyl alcohol and follow with a dry wipe.
7. To ensure bubble-free application, put three or four tiny drops of liquid detergent into a 24 oz. / 750 ml trigger-type spray bottle and fill with water. Replace the top and shake to mix the soap and water "surfactant." Set nozzle for a fine mist.

Note: It is strongly recommended not to use professional premixed surfactant, but to mix your own soap and water surfactant to control the how the part floats on the panel for positioning before activating the adhesion with the squeegee.

Note: See "Accessory Decal Installation Tips and Tricks" video for demonstration.

Installation Notes

1. All of the decals include premask carrier extensions and notches that allow the installer to accurately align the decal to the body panel.
2. The soap / water "surfactant" is intended to allow the installer the opportunity to position the stripe before any pre-adhesion can occur. If the decal sticks prematurely and does not easily "glide" across the surface of a body panel, increase the amount of surfactant that has been applied to the body panel and/or place additional soap into the spray bottle and re-spray.
3. The adhesive is activated by pressure. Be sure to use firm, overlapping strokes, beginning at the center of the decal and working toward the edges of the decal.

Note: Installer must use a lint free towel to cover edge of squeegee to prevent damage to decal once the premask is removed.

4. When using the squeegee, be careful not to drag the squeegee onto the painted body panel.
5. After premask removal, never use an uncovered squeegee to re-press a decal into place. Wrap the squeegee with a lint-free towel and re-spray the decal with surfactant before applying additional pressure.

6. The decals have a paper-premask carrier. Should this carrier be difficult to remove, spray the carrier paper with the surfactant and wait 10 seconds for the carrier to soften and release from the decal.
7. If bubbles are present after premask carrier removal, wrap a towel around the squeegee and carefully attempt to push bubble to the side of the decal. If the bubble cannot be moved, use a sewing needle to pierce the bubble and press the remaining solution from beneath the decal.

Note: The pin must be inserted in the side of the bubble, not the top to prevent the pin from breaking the paint and cause corrosion.

Note: See "Accessory Decal Installation Tips and Tricks" video for demonstration.

Caution: After a decal installation has been completed, do not high pressure wash the vehicle for 72 hours.

Installation Procedure

1. Using the wetting solution in the spray bottle, set the nozzle to a fine mist and saturate the fender.
2. Place the decal face-down on a flat surface and slowly remove the release liner (the adhesive will now be exposed).
3. Use the wetting solution to saturate the exposed adhesive side of the decal.

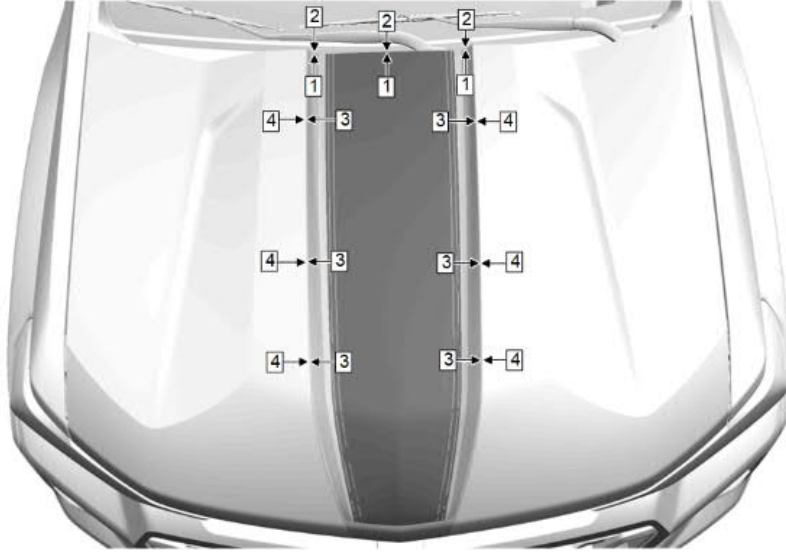

4. Align the rear edge of the premask carrier (1) to the rear edge edge of the hood panel (2).
5. Evenly align the side edges of premask (3) to the crease lines (4) in the hood panel.

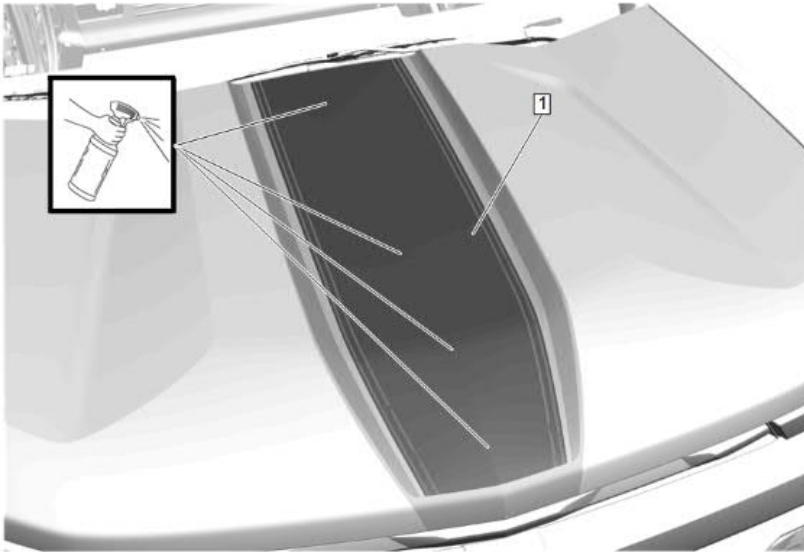

6. Spray the hood premask (1) with surfactant.

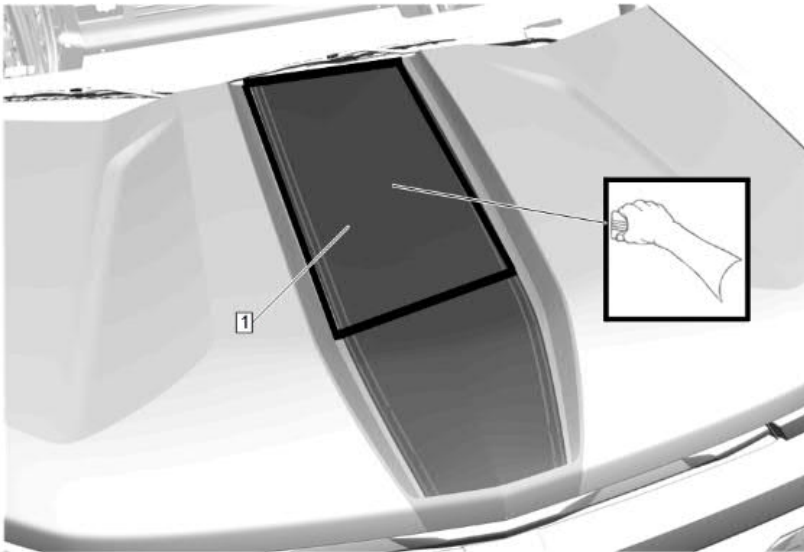

7. Starting at the rear, press the rear decal portion (1) into place.

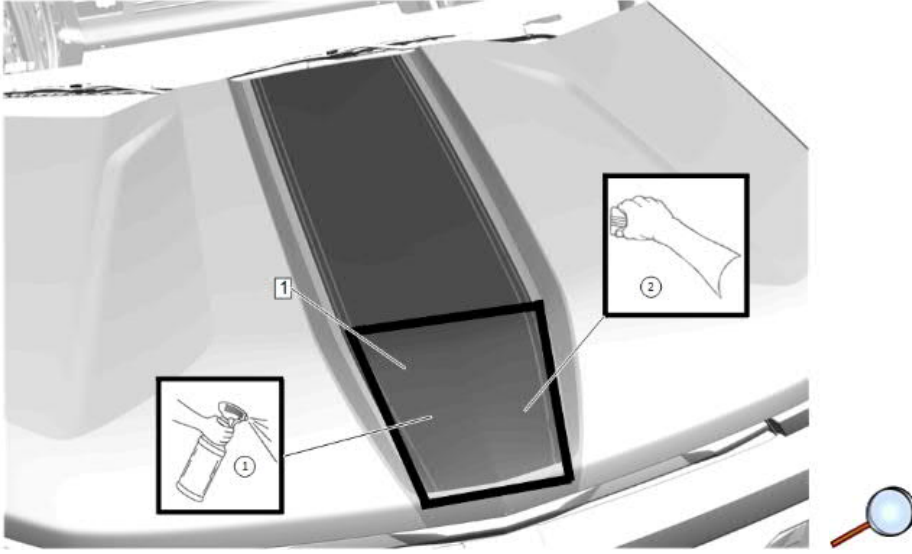

8. Spray the hood premask front area (1) generously with surfactant.

9. Squeegee the center of marked section (1) first and then along the crown in the hood to the front of the panel.

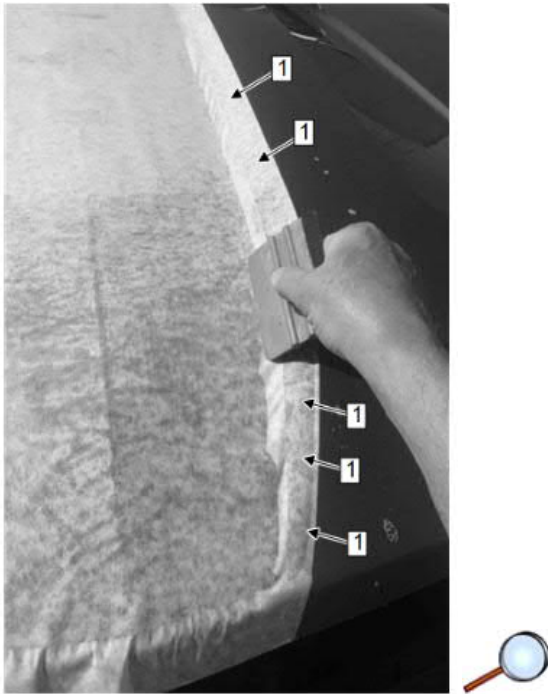

10. Make sure premask surface is very wet, then press the outer bands (1) into place and then follow with a squeegee. Re-spray premask as necessary.

11. Press any folds into place.

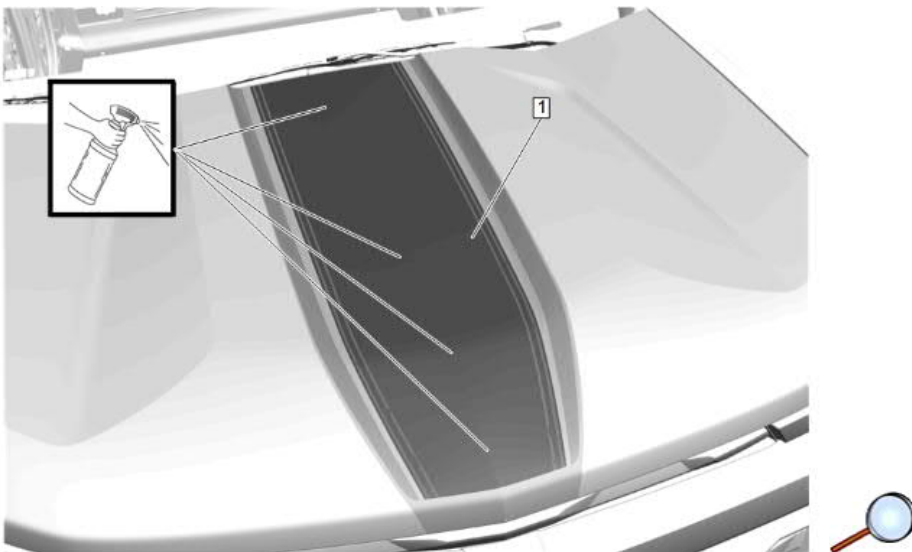

12. Re-spray the hood premask (1) with surfactant.

13. Inspect and wet out any visible bubbles that are remaining before removal of the premask carrier.



14. Carefully remove the premask (1).

15. After premask removal, NEVER use an uncovered squeegee to re-press a decal (2) into place. Wrap the squeegee with a towel and re-spray the surface with surfactant.

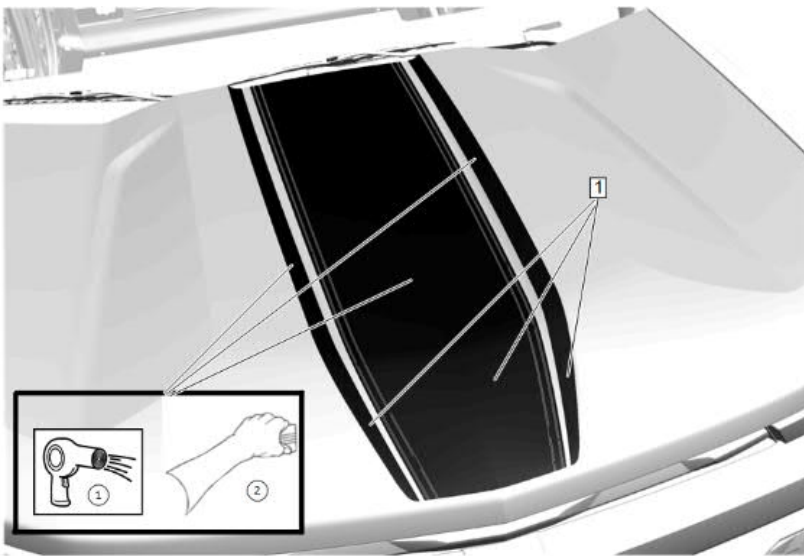

Caution: Use extreme care when using a hair dryer! DO NOT get too close to decal or heat too quickly as it will damage the decal. Apply heat evenly across the decal edge.

Note: Make sure to cover squeegee with a lint free towel at all times prior to pressing decal into place.

16. Use a hair dryer to warm the decal (1) and then re-press into place.

17. If there are any large bubbles or areas of lifting, wrap the squeegee with a lint free towel, re-spray decal with surfactant and re-press decal into place.

Note: The pin must be inserted in the side of the bubble, not the top to prevent the pin from breaking the paint and cause corrosion. See "Accessory Decal Installation Tips and Tricks" video for demonstration.

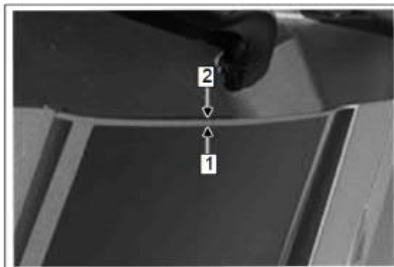

18. When done correctly, the rear of decal (1) should be approximately 1/8" from the panel edge (2) and the sides of decal (3) should be parallel to the crease lines (4) on hood.

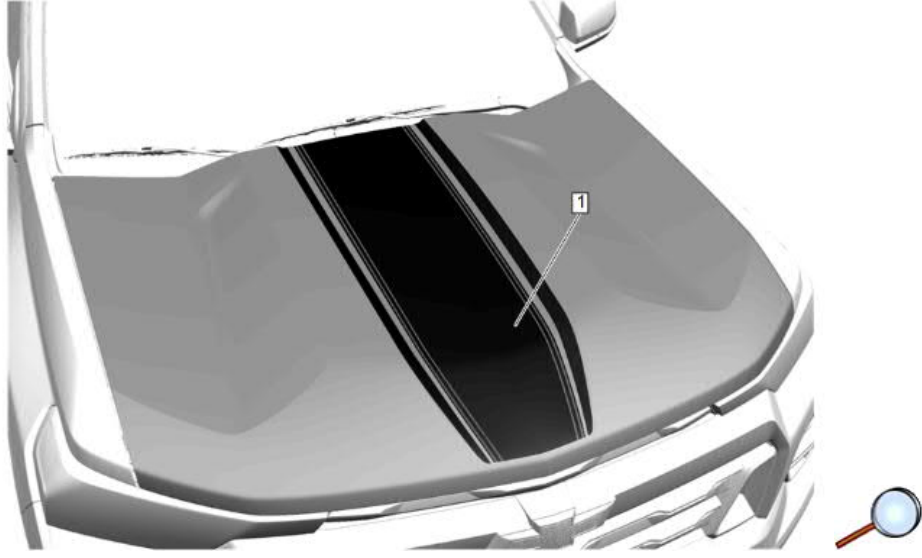

Note: After a decal installation has been complete, do not high pressure wash the vehicle for 72 hours.
19. Decal installation complete (1).