

# Body Emblem Package Installation

## Installation Instructions Part Number

86790667

### Kit Contents

Qty	Description
2	Emblem (Front Fascia) – "2500" (if equipped)
2	Emblem (Front Fascia) – "3500" (if equipped)
2	Emblem (Front Door) – "Sierra HD" (if equipped)
2	Emblem (Front Door) – "Denali HD" (if equipped)
2	Emblem (Front Door) – "AT4 HD" (if equipped)
2	Emblem (Front Door) – "AT4X HD" (if equipped)
1	Emblem (Endgate) – "Sierra" (if equipped)
1	Emblem (Endgate) – "SLE" (if equipped)
1	Emblem (Endgate) – "SLT" (if equipped)
1	Emblem (Endgate) – "Denali" (if equipped)
1	Emblem (Endgate) – "AT4" (if equipped)
1	Emblem (Endgate) – "AT4X" (if equipped)
2	Emblem (Pickup Box) – "4x4 (if equipped)
2	Emblem (Pickup Box) – "X31 (if equipped)
1	Emblem (Front Grille) – "AT4" (if equipped)
1	Emblem (Front Grille) – "AT4X" (if equipped)
1	Fender Vent (LH) 6.6L V8 Allison Transmission (if equipped)
1	Fender Vent (RH) 6.6L V8 Allison Transmission (if equipped)
1	Fender Vent (LH) Duramax (if equipped)
1	Fender Vent (RH) Duramax (if equipped)
1	Installation Instructions

### Tools Required

Masking Tape

Rubber Roller

Scissors

Plastic Flat-Bladed Tool

Isopropyl Alcohol

Lint Free Cloth

### Before you start

**Note:** For the nameplate to adhere best, the vehicle's mating surface (doors, endgate, etc.) should be free of damage (dents, scratches, creases, fractures, etc.).

**Caution:** Do not use heat gun/hair dryer or apply excessive heat to the emblem/nameplate as this may damage the paint and surrounding panel surfaces during removal.

**Caution:** Use a plastic, flat-bladed tool to prevent paint damage when removing an emblem/nameplate. Do not use fishing line to remove nameplate as this may worsen the tape residue cleaning process. Use Isopropyl Alcohol and Lint Free Cloth to remove tape residue. Heavy foam/adhesive residue remaining on the painted surface can be removed using 3M's Scotch-Brite™ Molding Adhesive and Stripe Removal 4-inch Foam Disc.

**Caution:** Only install nameplates as a direct replacement of the existing vehicle content.

- The part and surface should be 21°C (70°F) prior to installation. The vehicle should remain 21°C (70°F) for one hour after assembly to allow adhesive to develop sufficient bond strength.
- Wash the vehicle mating surfaces (Door, Pickup Box or Endgate) with a non-petroleum based cleaning product. If a stronger cleaner is required to remove any contaminants, use 3M® general purpose Adhesive Cleaner (P/N 08984). Then, thoroughly dry with a soft clean cloth.

## Front Fascia (2500 or 3500)

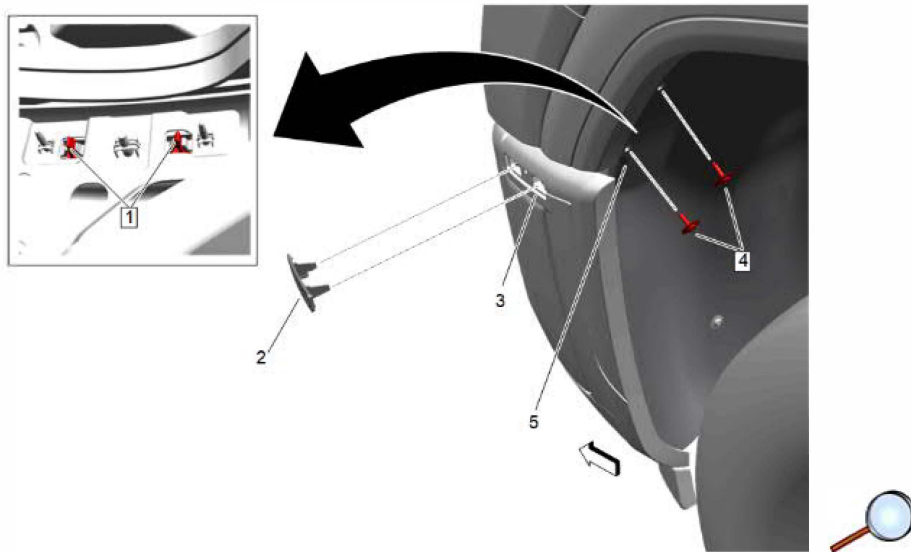

1. Remove two screws (4) from the front wheel liner. Pull the wheel liner (5) slightly rearward of the vehicle to gain hand access. Reach up and disengage the retaining tabs (1) and remove the emblem (2) from the front fascia (3).

2. Position the emblem (2) to the front fascia (3) making sure the retaining tabs (1) are engaged.

**Caution:** Use the correct fastener in the correct location. Replacement fasteners must be the correct part number for that application. Fasteners requiring replacement or fasteners requiring the use of thread locking compound or sealant are identified in the service procedure. Do not use paints, lubricants, or corrosion inhibitors on fasteners or fastener joint surfaces unless specified. These coatings affect fastener torque and joint clamping force and may damage the fastener. Use the correct tightening sequence and specifications when installing fasteners in order to avoid damage to parts and systems.

3. Reposition the wheel liner (5) and re-install the two screws. Tighten screws to 2.5 N.m (22 lb in).

4. Repeat the same procedure for the opposite side.

## Side Front Door (Sierra HD)

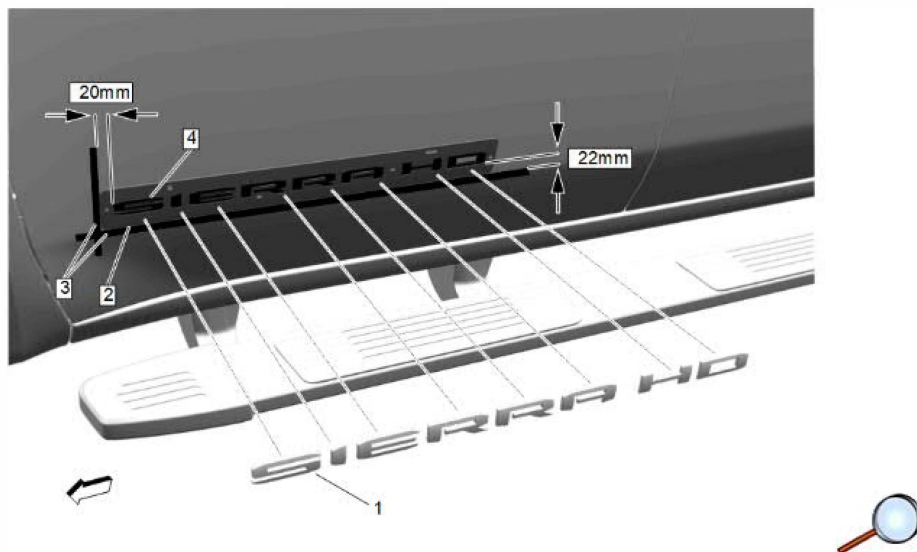

1. Apply masking tape (3) around the existing nameplate to be replaced. The tape needs to be 20mm to the left and 22mm below the existing nameplate. These will be the locating features for the new accessory nameplate.

2. Use a plastic flat-bladed tool to remove the chrome nameplate (1).

3. Clean and prep surface completely using an Isopropyl Alcohol Solution with a lint free cloth and allow to dry completely before installation.

4. Take the nameplate and peel the protective liner from the adhesive backing on the rear of the nameplate. Be careful not to touch the tape with hands and do not allow the tape to come into contact with dirt or any foreign matter prior to adhesion.

**Note:** Make sure the foam carrier and nameplate stay together during installation.

5. **IMPORTANT:** The adhesive will bond quickly to the paint. In the event that the nameplate should be mis-aligned after installation, do not attempt to remove the nameplate as this will cause paint damage. To avoid mis-alignment, do not drop the nameplate into place. Instead, first align the bottom edge of the foam carrier (2) of the nameplate to the masking tape. Then, toggle the nameplate (4) with foam carrier (2) into place.

6. Using the palm of the hand or an applicable roller with approximately 10 lbs of pressure, to ensure full adhesion of the nameplate.

7. Remove the foam carrier (2) and the protective liner from the front of the nameplate.

8. Remove masking tape.

9. Repeat the same procedure for the opposite side.

## Endgate Emblem (Sierra)

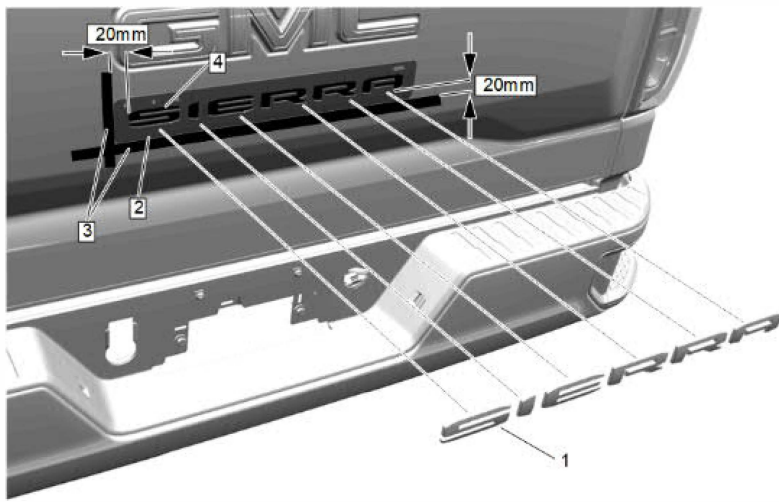

1. Apply masking tape (3) around the existing nameplate to be replaced. The tape needs to be 20mm to the left and 20mm below the existing nameplate. These will be the locating features for the new accessory nameplate.
2. Use a plastic flat-bladed tool to remove the chrome nameplate (1).
3. Clean and prep surface completely using an Isopropyl Alcohol Solution with a lint free cloth and allow to dry completely before installation.
4. Take the nameplate and peel the protective liner from the adhesive backing on the rear of the nameplate. Be careful not to touch the tape with hands and do not allow the tape to come into contact with dirt or any foreign matter prior to adhesion.  
**Note:** Make sure the foam carrier and nameplate stay together during installation.
5. **IMPORTANT:** The adhesive will bond quickly to the paint. In the event that the nameplate should be mis-aligned after installation, do not attempt to remove the nameplate as this will cause paint damage. To avoid mis-alignment, do not drop the nameplate into place. Instead, first align the bottom edge of the foam carrier (2) of the nameplate to the masking tape. Then, toggle the nameplate (4) with foam carrier (2) into place.
6. Using the palm of the hand or an applicable roller with approximately 10 lbs of pressure, to ensure full adhesion of the nameplate.
7. Remove the foam carrier (2) and the protective liner from the front of the nameplate.
8. Remove masking tape.

## Endgate Emblem (SLE)

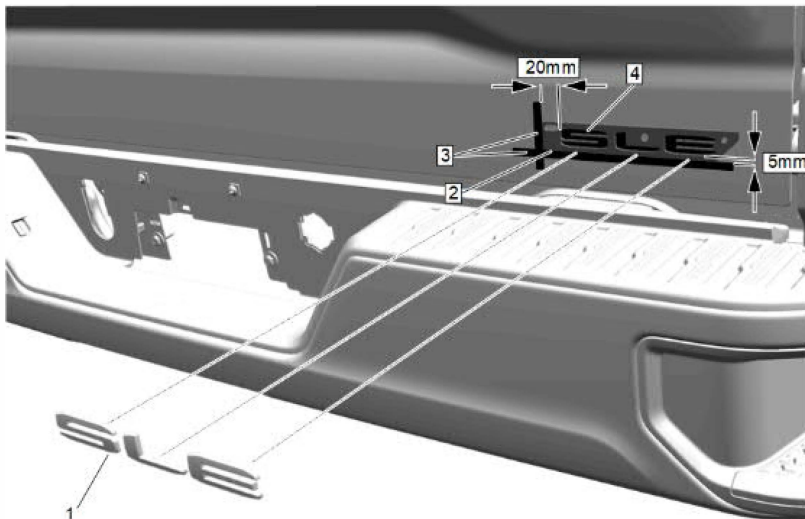

1. Apply masking tape (3) around the existing nameplate to be replaced. The tape needs to be 20mm to the left and 5mm below the existing nameplate. These will be the locating features for the new accessory nameplate.
2. Use a plastic flat-bladed tool to remove the chrome nameplate (1).
3. Clean and prep surface completely using an Isopropyl Alcohol Solution with a lint free cloth and allow to dry completely before installation.
4. Take the nameplate and peel the protective liner from the adhesive backing on the rear of the nameplate. Be careful not to touch the tape with hands and do not allow the tape to come into contact with dirt or any foreign matter prior to adhesion.  
**Note:** Make sure the foam carrier and nameplate stay together during installation.
5. **IMPORTANT:** The adhesive will bond quickly to the paint. In the event that the nameplate should be mis-aligned after installation, do not attempt to remove the nameplate as this will cause paint damage. To avoid mis-alignment, do not drop the nameplate into place. Instead, first align the bottom edge of the foam carrier (2) of the nameplate to the masking tape. Then, toggle the nameplate (4) with foam carrier (2) into place.
6. Using the palm of the hand or an applicable roller with approximately 10 lbs of pressure, to ensure full adhesion of the nameplate.
7. Remove the foam carrier (2) and the protective liner from the front of the nameplate.
8. Remove masking tape.

## Endgate Emblem (SL T)

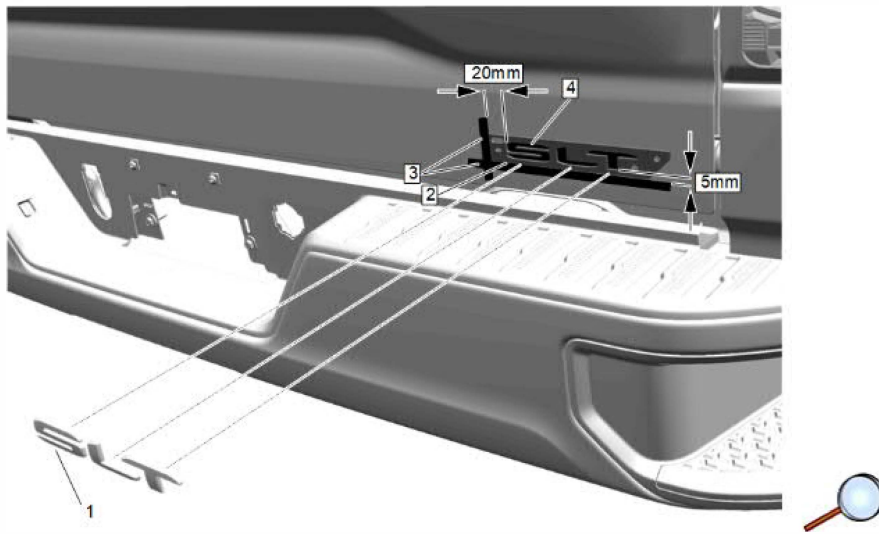

1. Apply masking tape (3) around the existing nameplate to be replaced. The tape needs to be 20mm to the left and 5mm below the existing nameplate. These will be the locating features for the new accessory nameplate.
2. Use a plastic flat-bladed tool to remove the chrome nameplate (1).
3. Clean and prep surface completely using an Isopropyl Alcohol Solution with a lint free cloth and allow to dry completely before installation.
4. Take the nameplate and peel the protective liner from the adhesive backing on the rear of the nameplate. Be careful not to touch the tape with hands and do not allow the tape to come into contact with dirt or any foreign matter prior to adhesion.  
**Note:** Make sure the foam carrier and nameplate stay together during installation.
5. **IMPORTANT:** The adhesive will bond quickly to the paint. In the event that the nameplate should be mis-aligned after installation, do not attempt to remove the nameplate as this will cause paint damage. To avoid mis-alignment, do not drop the nameplate into place. Instead, first align the bottom edge of the foam carrier (2) of the nameplate to the masking tape. Then, toggle the nameplate (4) with foam carrier (2) into place.
6. Using the palm of the hand or an applicable roller with approximately 10 lbs of pressure, to ensure full adhesion of the nameplate.
7. Remove the foam carrier (2) and the protective liner from the front of the nameplate.
8. Remove masking tape.

## Pickup Box Emblem (4x4)

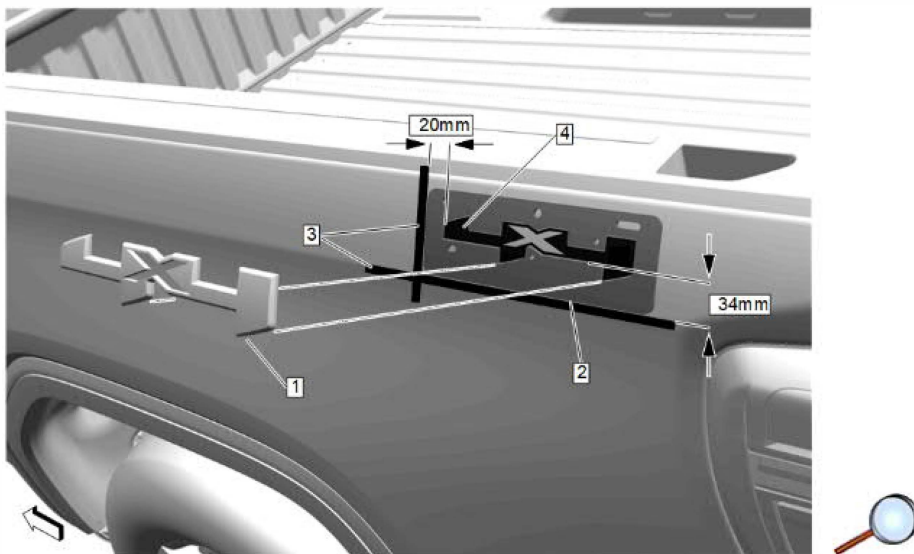

1. Apply masking tape (3) around the existing nameplate to be replaced. The tape needs to be 20mm to the left and 34mm below the existing nameplate. These will be the locating features for the new accessory nameplate.
2. Use a plastic flat-bladed tool to remove the chrome nameplate (1).
3. Clean and prep surface completely using an Isopropyl Alcohol Solution with a lint free cloth and allow to dry completely before installation.
4. Take the nameplate and peel the protective liner from the adhesive backing on the rear of the nameplate. Be careful not to touch the tape with hands and do not allow the tape to come into contact with dirt or any foreign matter prior to adhesion.  
**Note:** Make sure the foam carrier and nameplate stay together during installation.
5. **IMPORTANT:** The adhesive will bond quickly to the paint. In the event that the nameplate should be mis-aligned after installation, do not attempt to remove the nameplate as this will cause paint damage. To avoid mis-alignment, do not drop the nameplate into place. Instead, first align the bottom edge of the foam carrier (2) of the nameplate to the masking tape. Then, toggle the nameplate (4) with foam carrier (2) into place.
6. Using the palm of the hand or an applicable roller with approximately 10 lbs of pressure, to ensure full adhesion of the nameplate.
7. Remove the foam carrier (2) and the protective liner from the front of the nameplate.
8. Remove masking tape.
9. Repeat the same procedure for the opposite side.

## Pickup Box Emblem (X31)

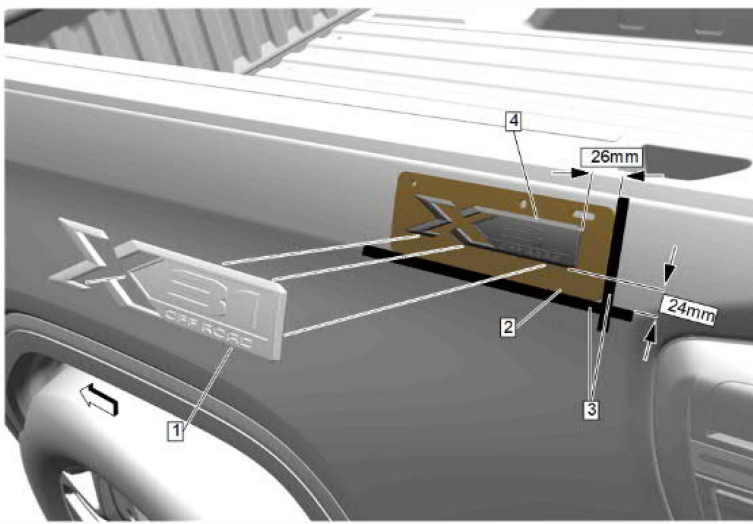

1. Apply masking tape (3) around the existing nameplate to be replaced. The tape needs to be 26mm to the right and 24mm below the existing nameplate. These will be the locating features for the new accessory nameplate.
2. Use a plastic flat-bladed tool to remove the chrome nameplate (1).
3. Clean and prep surface completely using an Isopropyl Alcohol Solution with a lint free cloth and allow to dry completely before installation.
4. Take the nameplate and peel the protective liner from the adhesive backing on the rear of the nameplate. Be careful not to touch the tape with hands and do not allow the tape to come into contact with dirt or any foreign matter prior to adhesion.  
**Note:** Make sure the foam carrier and nameplate stay together during installation.
5. **IMPORTANT:** The adhesive will bond quickly to the paint. In the event that the nameplate should be mis-aligned after installation, do not attempt to remove the nameplate as this will cause paint damage. To avoid mis-alignment, do not drop the nameplate into place. Instead, first align the bottom edge of the foam carrier (2) of the nameplate to the masking tape. Then, toggle the nameplate (4) with foam carrier (2) into place.
6. Using the palm of the hand or an applicable roller with approximately 10 lbs of pressure, to ensure full adhesion of the nameplate.
7. Remove the foam carrier (2) and the protective liner from the front of the nameplate.
8. Remove masking tape.
9. Repeat the same procedure for the opposite side.

## Denali Edition

### Front Fascia (2500 or 3500)

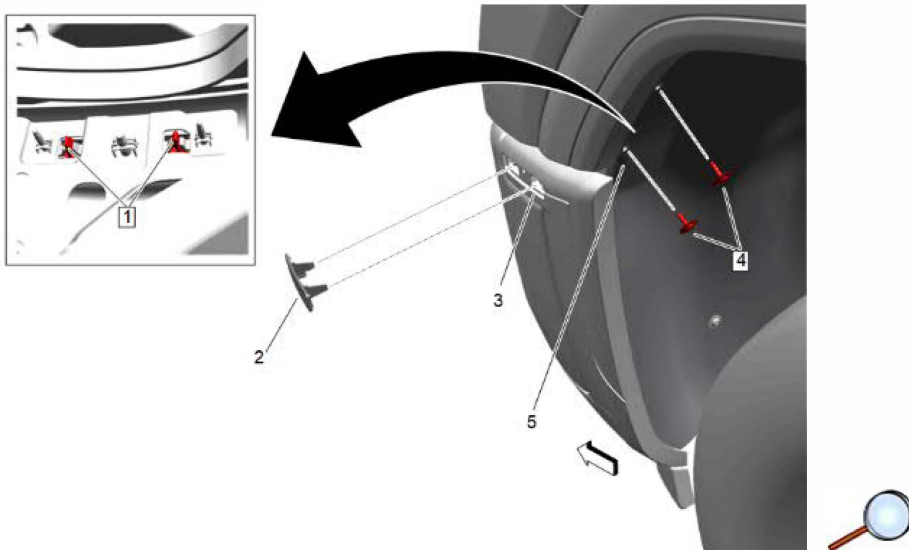

1. Remove two screws (4) from the front wheel liner. Pull the wheel liner (5) slightly rearward of the vehicle to gain hand access. Reach up and disengage the retaining tabs (1) and remove the emblem (2) from the front fascia (3).
2. Position the emblem (2) to the front fascia (3) making sure the retaining tabs (1) are engaged.
3. Reposition the wheel liner (5) and re-install the two screws. Tighten screws to 2.5 N.m (22 lb in).
4. Repeat the same procedure for the opposite side.

## Side Front Door (Denali HD)

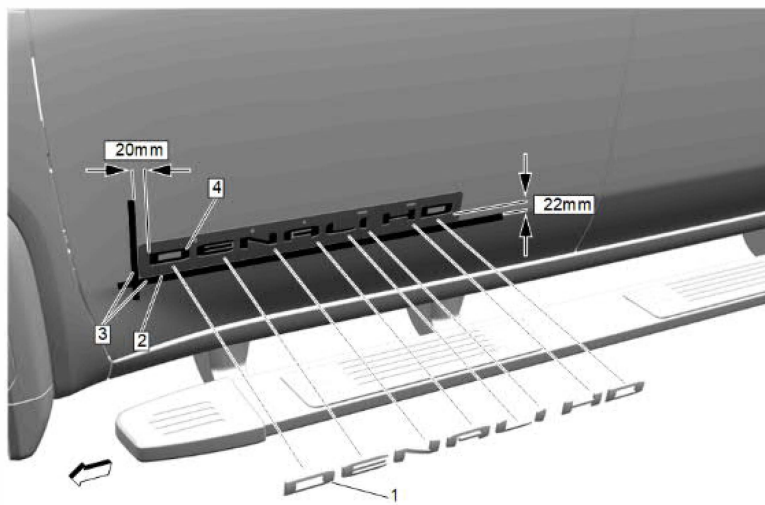

1. Apply masking tape (3) around the existing nameplate to be replaced. The tape needs to be 20mm to the left and 22mm below the existing nameplate. These will be the locating features for the new accessory nameplate.
  2. Use a plastic flat-bladed tool to remove the chrome nameplate (1).
  3. Clean and prep surface completely using an Isopropyl Alcohol Solution with a lint free cloth and allow to dry completely before installation.
  4. Take the nameplate and peel the protective liner from the adhesive backing on the rear of the nameplate. Be careful not to touch the tape with hands and do not allow the tape to come into contact with dirt or any foreign matter prior to adhesion.
- Note:** Make sure the foam carrier and nameplate stay together during installation.
5. **IMPORTANT:** The adhesive will bond quickly to the paint. In the event that the nameplate should be mis-aligned after installation, do not attempt to remove the nameplate as this will cause paint damage. To avoid mis-alignment, do not drop the nameplate into place. Instead, first align the bottom edge of the foam carrier (2) of the nameplate to the masking tape. Then, toggle the nameplate (4) with foam carrier (2) into place.
  6. Using the palm of the hand or an applicable roller with approximately 10 lbs of pressure, to ensure full adhesion of the nameplate.
  7. Remove the foam carrier (2) and the protective liner from the front of the nameplate.
  8. Remove masking tape.
  9. Repeat the same procedure for the opposite side.

## Endgate Emblem (Sierra)

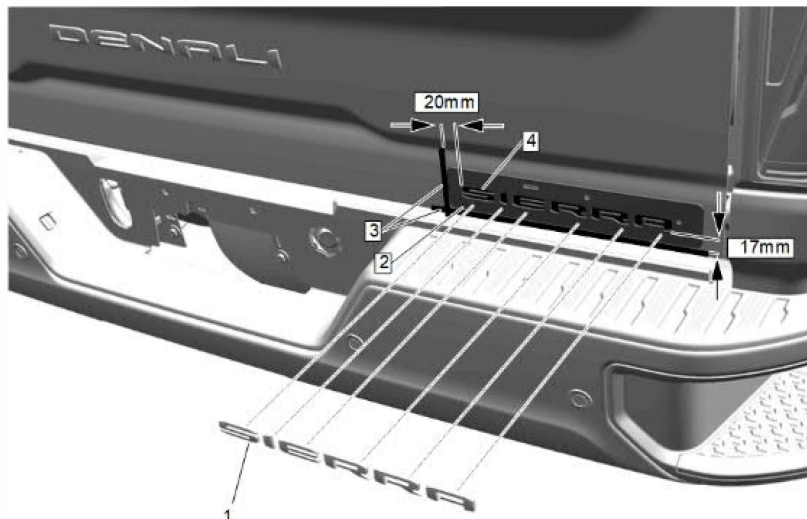

1. Apply masking tape (3) around the existing nameplate to be replaced. The tape needs to be 20mm to the left and 17mm below the existing nameplate. These will be the locating features for the new accessory nameplate.
  2. Use a plastic flat-bladed tool to remove the chrome nameplate (1).
  3. Clean and prep surface completely using an Isopropyl Alcohol Solution with a lint free cloth and allow to dry completely before installation.
  4. Take the nameplate and peel the protective liner from the adhesive backing on the rear of the nameplate. Be careful not to touch the tape with hands and do not allow the tape to come into contact with dirt or any foreign matter prior to adhesion.
- Note:** Make sure the foam carrier and nameplate stay together during installation.
5. **IMPORTANT:** The adhesive will bond quickly to the paint. In the event that the nameplate should be mis-aligned after installation, do not attempt to remove the nameplate as this will cause paint damage. To avoid mis-alignment, do not drop the nameplate into place. Instead, first align the bottom edge of the foam carrier (2) of the nameplate to the masking tape. Then, toggle the nameplate (4) with foam carrier (2) into place.
  6. Using the palm of the hand or an applicable roller with approximately 10 lbs of pressure, to ensure full adhesion of the nameplate.
  7. Remove the foam carrier (2) and the protective liner from the front of the nameplate.
  8. Remove masking tape.

## Endgate Emblem (Denali)

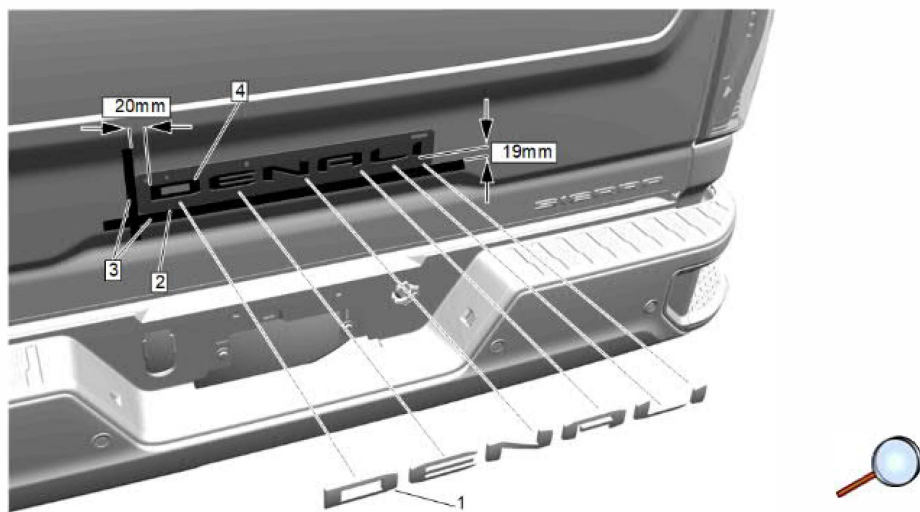

1. Apply masking tape (3) around the existing nameplate to be replaced. The tape needs to be 20mm to the left and 19mm below the existing nameplate. These will be the locating features for the new accessory nameplate.
2. Use a plastic flat-bladed tool to remove the chrome nameplate (1).
3. Clean and prep surface completely using an Isopropyl Alcohol Solution with a lint free cloth and allow to dry completely before installation.
4. Take the nameplate and peel the protective liner from the adhesive backing on the rear of the nameplate. Be careful not to touch the tape with hands and do not allow the tape to come into contact with dirt or any foreign matter prior to adhesion.  
**Note:** Make sure the foam carrier and nameplate stay together during installation.
5. **IMPORTANT:** The adhesive will bond quickly to the paint. In the event that the nameplate should be mis-aligned after installation, do not attempt to remove the nameplate as this will cause paint damage. To avoid mis-alignment, do not drop the nameplate into place. Instead, first align the bottom edge of the foam carrier (2) of the nameplate to the masking tape. Then, toggle the nameplate (4) with foam carrier (2) into place.
6. Using the palm of the hand or an applicable roller with approximately 10 lbs of pressure, to ensure full adhesion of the nameplate.
7. Remove the foam carrier (2) and the protective liner from the front of the nameplate.
8. Remove masking tape.

## AT4 Edition

### Front Fascia (2500 or 3500)

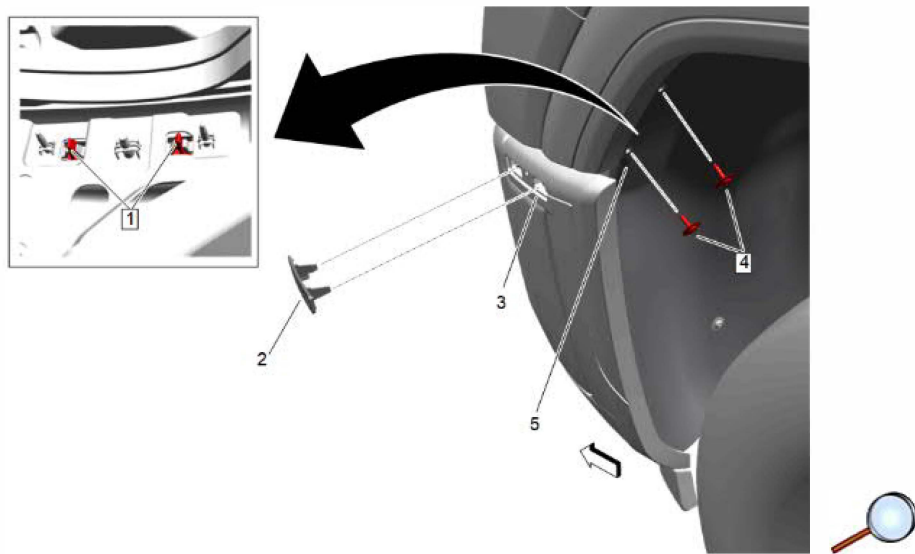

1. Remove two screws (4) from the front wheel liner. Pull the wheel liner (5) slightly rearward of the vehicle to gain hand access. Reach up and disengage the retaining tabs (1) and remove the emblem (2) from the front fascia (3).
2. Position the emblem (2) to the front fascia (3) making sure the retaining tabs (1) are engaged.
3. Reposition the wheel liner (5) and re-install the two screws. Tighten screws to 2.5 N.m (22 lb in).
4. Repeat the same procedure for the opposite side.

## Side Front Door (AT4 HD)

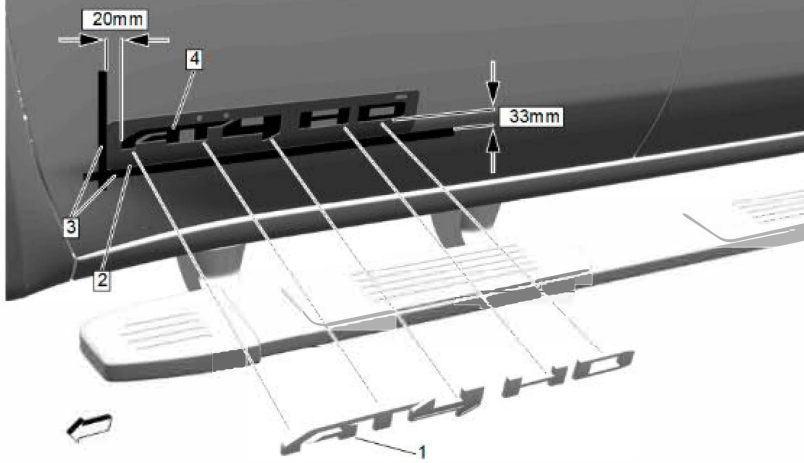

1. Apply masking tape (3) around the existing nameplate to be replaced. The tape needs to be 20mm to the left and 33mm below the existing nameplate. These will be the locating features for the new accessory nameplate.
  2. Use a plastic flat-bladed tool to remove the chrome nameplate (1).
  3. Clean and prep surface completely using an Isopropyl Alcohol Solution with a lint free cloth and allow to dry completely before installation.
  4. Take the nameplate and peel the protective liner from the adhesive backing on the rear of the nameplate. Be careful not to touch the tape with hands and do not allow the tape to come into contact with dirt or any foreign matter prior to adhesion.
- Note:** Make sure the foam carrier and nameplate stay together during installation.
5. **IMPORTANT:** The adhesive will bond quickly to the paint. In the event that the nameplate should be mis-aligned after installation, do not attempt to remove the nameplate as this will cause paint damage. To avoid mis-alignment, do not drop the nameplate into place. Instead, first align the bottom edge of the foam carrier (2) of the nameplate to the masking tape. Then, toggle the nameplate (4) with foam carrier (2) into place.
  6. Using the palm of the hand or an applicable roller with approximately 10 lbs of pressure, to ensure full adhesion of the nameplate.
  7. Remove the foam carrier (2) and the protective liner from the front of the nameplate.
  8. Remove masking tape.
  9. Repeat the same procedure for the opposite side.

## Endgate Emblem (Sierra)

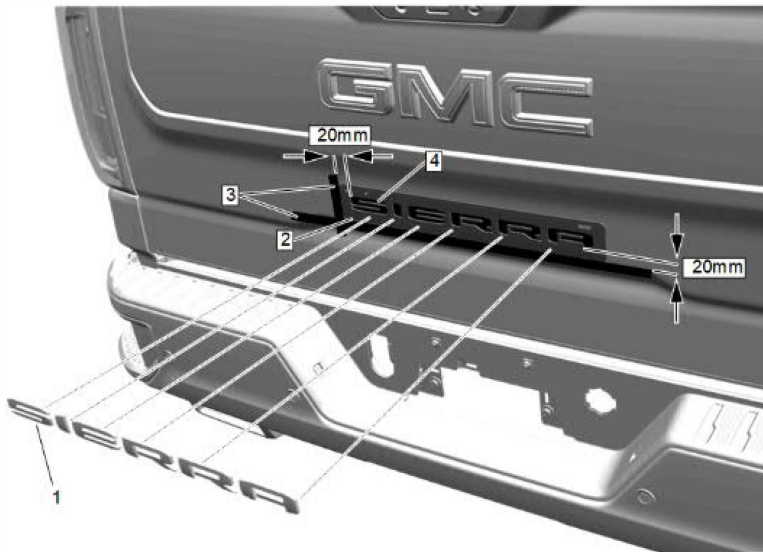

1. Apply masking tape (3) around the existing nameplate to be replaced. The tape needs to be 20mm to the left and 20mm below the existing nameplate. These will be the locating features for the new accessory nameplate.
  2. Use a plastic flat-bladed tool to remove the chrome nameplate (1).
  3. Clean and prep surface completely using an Isopropyl Alcohol Solution with a lint free cloth and allow to dry completely before installation.
  4. Take the nameplate and peel the protective liner from the adhesive backing on the rear of the nameplate. Be careful not to touch the tape with hands and do not allow the tape to come into contact with dirt or any foreign matter prior to adhesion.
- Note:** Make sure the foam carrier and nameplate stay together during installation.
5. **IMPORTANT:** The adhesive will bond quickly to the paint. In the event that the nameplate should be mis-aligned after installation, do not attempt to remove the nameplate as this will cause paint damage. To avoid mis-alignment, do not drop the nameplate into place. Instead, first align the bottom edge of the foam carrier (2) of the nameplate to the masking tape. Then, toggle the nameplate (4) with foam carrier (2) into place.
  6. Using the palm of the hand or an applicable roller with approximately 10 lbs of pressure, to ensure full adhesion of the nameplate.
  7. Remove the foam carrier (2) and the protective liner from the front of the nameplate.
  8. Remove masking tape.

## Endgate Emblem (AT4)

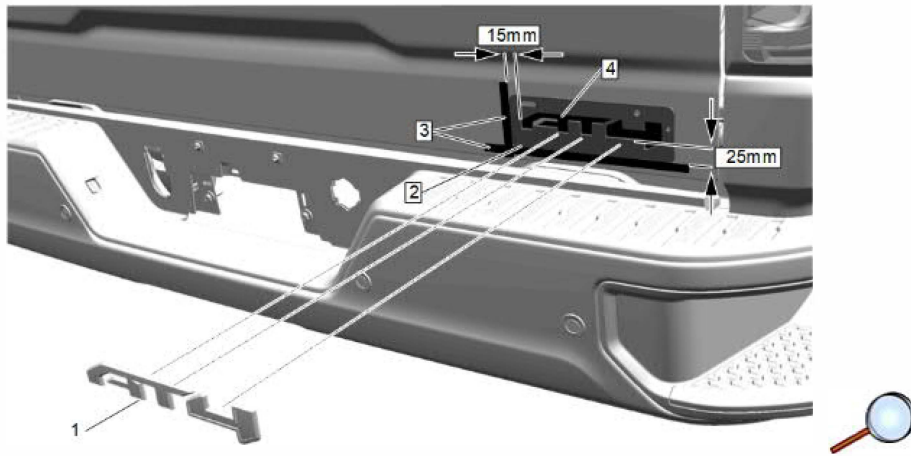

1. Apply masking tape (3) around the existing nameplate to be replaced. The tape needs to be 15mm to the left and 25mm below the existing nameplate. These will be the locating features for the new accessory nameplate.
2. Use a plastic flat-bladed tool to remove the chrome nameplate (1).
3. Clean and prep surface completely using an Isopropyl Alcohol Solution with a lint free cloth and allow to dry completely before installation.
4. Take the nameplate and peel the protective liner from the adhesive backing on the rear of the nameplate. Be careful not to touch the tape with hands and do not allow the tape to come into contact with dirt or any foreign matter prior to adhesion.  
**Note:** Make sure the foam carrier and nameplate stay together during installation.
5. **IMPORTANT:** The adhesive will bond quickly to the paint. In the event that the nameplate should be mis-aligned after installation, do not attempt to remove the nameplate as this will cause paint damage. To avoid mis-alignment, do not drop the nameplate into place. Instead, first align the bottom edge of the foam carrier (2) of the nameplate to the masking tape. Then, toggle the nameplate (4) with foam carrier (2) into place.
6. Using the palm of the hand or an applicable roller with approximately 10 lbs of pressure, to ensure full adhesion of the nameplate.
7. Remove the foam carrier (2) and the protective liner from the front of the nameplate.
8. Remove masking tape.

## Front Grille Emblem (AT4)

1. Remove the front grille. Refer to [Front Grille Replacement](#) in Vehicle Service Manual.

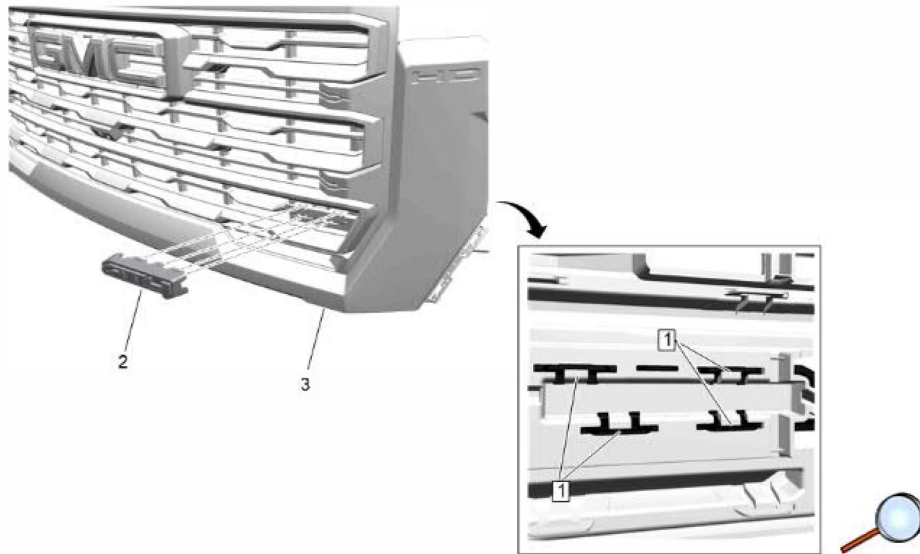

2. From the backside of grille, disengage the retainers (1) and remove emblem (2) from front grille (3).
3. Position emblem (2) to front grille (3) making sure retainers (1) are engaged.
4. Reinstall the front grille. Refer to [Front Grille Replacement](#) in Vehicle Service Manual.

## Front Fascia (2500 or 3500)

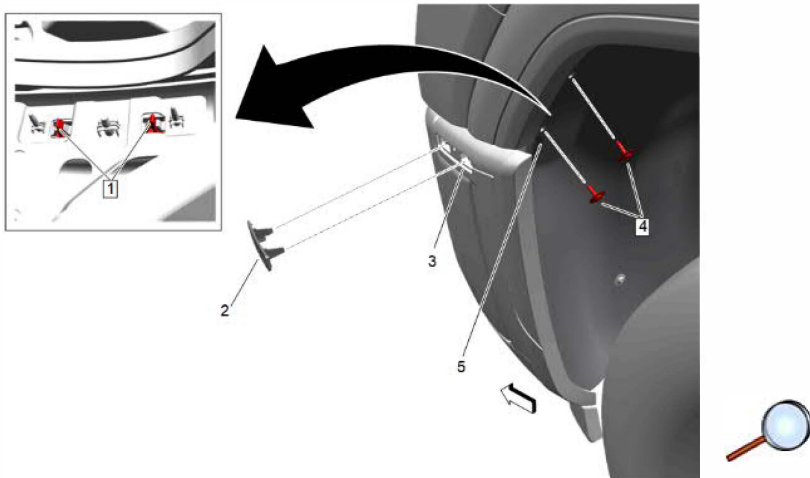

1. Remove two screws (4) from the front wheel liner. Pull the wheel liner (5) slightly rearward of the vehicle to gain hand access. Reach up and disengage the retaining tabs (1) and remove the emblem (2) from the front fascia (3).
2. Position the emblem (2) to the front fascia (3) making sure the retaining tabs (1) are engaged.
3. Reposition the wheel liner (5) and re-install the two screws. Tighten screws to 2.5 N.m (22 lb in).
4. Repeat the same procedure for the opposite side.

## Side Front Door (AT4X HD)

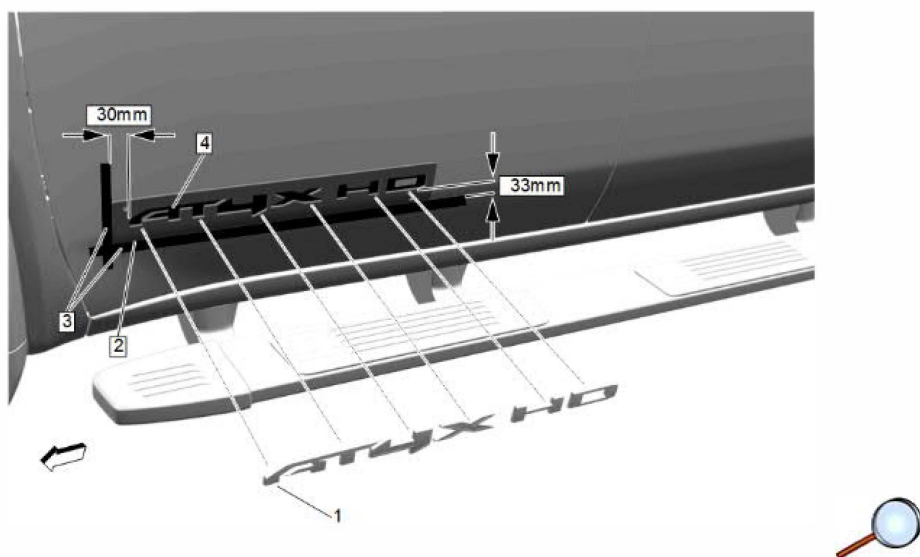

1. Apply masking tape (3) around the existing nameplate to be replaced. The tape needs to be 30mm to the left and 33mm below the existing nameplate. These will be the locating features for the new accessory nameplate.
  2. Use a plastic flat-bladed tool to remove the chrome nameplate (1).
  3. Clean and prep surface completely using an Isopropyl Alcohol Solution with a lint free cloth and allow to dry completely before installation.
  4. Take the nameplate and peel the protective liner from the adhesive backing on the rear of the nameplate. Be careful not to touch the tape with hands and do not allow the tape to come into contact with dirt or any foreign matter prior to adhesion.
- Note:** Make sure the foam carrier and nameplate stay together during installation.
5. **IMPORTANT:** The adhesive will bond quickly to the paint. In the event that the nameplate should be mis-aligned after installation, do not attempt to remove the nameplate as this will cause paint damage. To avoid mis-alignment, do not drop the nameplate into place. Instead, first align the bottom edge of the foam carrier (2) of the nameplate to the masking tape. Then, toggle the nameplate (4) with foam carrier (2) into place.
  6. Using the palm of the hand or an applicable roller with approximately 10 lbs of pressure, to ensure full adhesion of the nameplate.
  7. Remove the foam carrier (2) and the protective liner from the front of the nameplate.
  8. Remove masking tape.
  9. Repeat the same procedure for the opposite side.

## Endgate Emblem (Sierra)

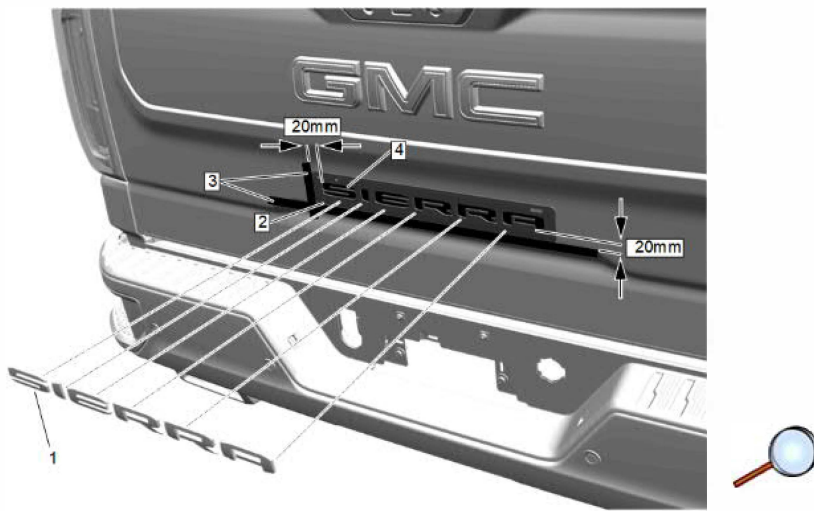

1. Apply masking tape (3) around the existing nameplate to be replaced. The tape needs to be 20mm to the left and 20mm below the existing nameplate. These will be the locating features for the new accessory nameplate.
  2. Use a plastic flat-bladed tool to remove the chrome nameplate (1).
  3. Clean and prep surface completely using an Isopropyl Alcohol Solution with a lint free cloth and allow to dry completely before installation.
  4. Take the nameplate and peel the protective liner from the adhesive backing on the rear of the nameplate. Be careful not to touch the tape with hands and do not allow the tape to come into contact with dirt or any foreign matter prior to adhesion.
- Note:** Make sure the foam carrier and nameplate stay together during installation.
5. **IMPORTANT:** The adhesive will bond quickly to the paint. In the event that the nameplate should be mis-aligned after installation, do not attempt to remove the nameplate as this will cause paint damage. To avoid mis-alignment, do not drop the nameplate into place. Instead, first align the bottom edge of the foam carrier (2) of the nameplate to the masking tape. Then, toggle the nameplate (4) with foam carrier (2) into place.
  6. Using the palm of the hand or an applicable roller with approximately 10 lbs of pressure, to ensure full adhesion of the nameplate.
  7. Remove the foam carrier (2) and the protective liner from the front of the nameplate.
  8. Remove masking tape.

## Endgate Emblem (AT4X)

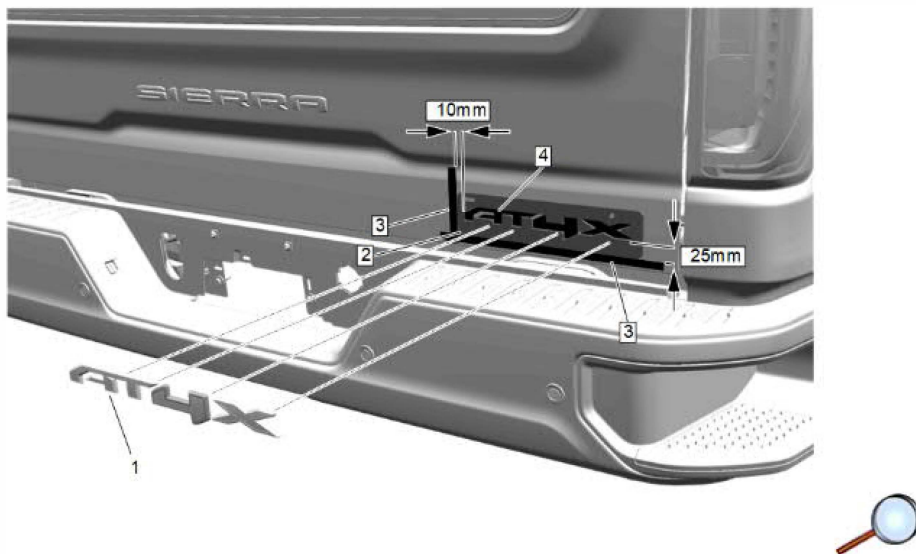

1. Apply masking tape (3) around the existing nameplate to be replaced. The tape needs to be 10mm to the left and 25mm below the existing nameplate. These will be the locating features for the new accessory nameplate.
  2. Use a plastic flat-bladed tool to remove the chrome nameplate (1).
  3. Clean and prep surface completely using an Isopropyl Alcohol Solution with a lint free cloth and allow to dry completely before installation.
  4. Take the nameplate and peel the protective liner from the adhesive backing on the rear of the nameplate. Be careful not to touch the tape with hands and do not allow the tape to come into contact with dirt or any foreign matter prior to adhesion.
- Note:** Make sure the foam carrier and nameplate stay together during installation.
5. **IMPORTANT:** The adhesive will bond quickly to the paint. In the event that the nameplate should be mis-aligned after installation, do not attempt to remove the nameplate as this will cause paint damage. To avoid mis-alignment, do not drop the nameplate into place. Instead, first align the bottom edge of the foam carrier (2) of the nameplate to the masking tape. Then, toggle the nameplate (4) with foam carrier (2) into place.
  6. Using the palm of the hand or an applicable roller with approximately 10 lbs of pressure, to ensure full adhesion of the nameplate.
  7. Remove the foam carrier (2) and the protective liner from the front of the nameplate.
  8. Remove masking tape.

## Front Grille Emblem (AT4X)

1. Remove the front grille. Refer to [Front Grille Re1:1](#) placement in Vehicle Service Manual.

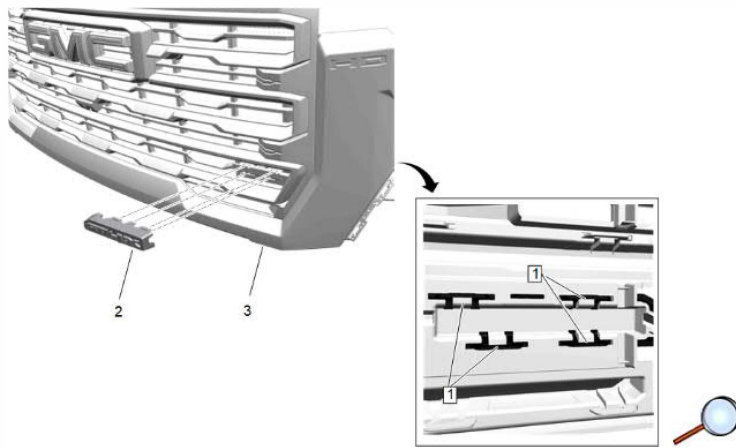

2. From the backside of grille, disengage the retainers (1) and remove emblem (2) from front grille (3).
3. Position emblem (2) to front grille (3) making sure retainers (1) are engaged.
4. Reinstall the front grille. Refer to [Front Grille Replacement](#) in Vehicle Service Manual.

## Fender Vent

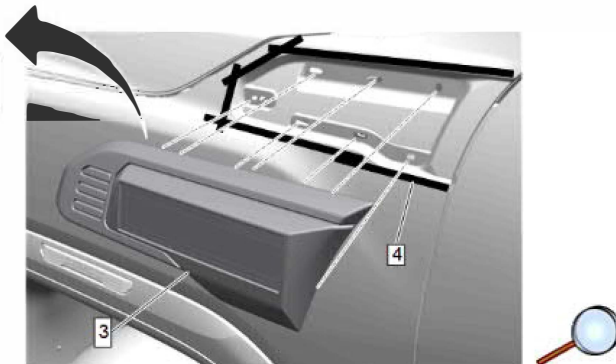
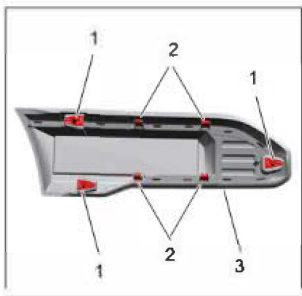

**Caution:** Only install emblems as a direct replacement of the existing vehicle content and discard any unused part.

1. Apply a double layer of masking tape (4) around the perimeter of the painted surfaces.
2. Using a plastic flat bladed tool, disengage the retainers (1), clips (2) and remove fender vent (3).
3. Remove masking tape (4).

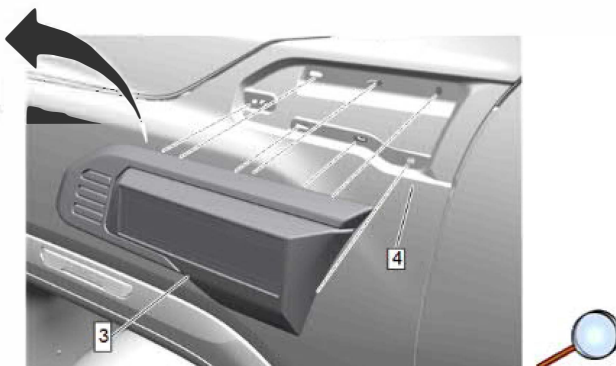
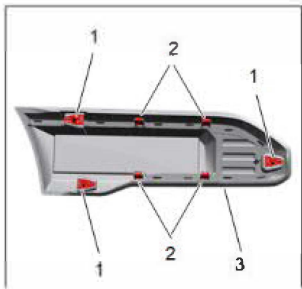

4. Install the fender vent (3) to fender (4) making sure to engage the retainers (1) and clips (2).
5. Repeat the same procedure for the opposite side.